



US00D362488S

United States Patent [19]

[11] Patent Number: Des. 362,488

Lee

[45] Date of Patent: ** Sep. 19, 1995

[54] GAS REGULATOR

[75] Inventor: Edward R. Lee, Martindale, Tex.

[73] Assignee: S. H. Leggett Company, San Marcos, Tex.

[**] Term: 14 Years

[21] Appl. No.: 27,485

[22] Filed: Aug. 22, 1994

Related U.S. Application Data

[63] Continuation of Ser. No. 878,888, May 5, 1992, abandoned.

[52] U.S. Cl. D23/235

[58] Field of Search D23/233-237, D23/244-249; 251/229, 230; 137/460, 505.42, 505.46, 519.5, 607

[56] References Cited

U.S. PATENT DOCUMENTS

D. 115,780	7/1939	Carnes	D23/235
D. 154,624	7/1949	Neiseman et al.	D23/235
D. 168,641	1/1953	St. Clair et al.	D23/235
D. 181,319	10/1957	Schutmaat	D23/235
360,890	4/1887	Kieley	137/505.46 X
408,873	8/1889	Crozier	137/505.46 X

Primary Examiner—Louis S. Zarfes

Assistant Examiner—E. Watterson

Attorney, Agent, or Firm—Price, Heneveld, Cooper, Dewitt & Litton

[57] CLAIM

The ornamental design for the gas regulator, as shown and described.

DESCRIPTION

FIG. 1 is an overhead plan view of a gas regulator embodying my design;

FIG. 2 is a side elevational view thereof;

FIG. 3 is a bottom plan view thereof;

FIG. 4 is a front elevational view thereof;

FIG. 5 is a rear elevational view thereof;

FIG. 6 is an overhead plan view similar to FIG. 1 but showing a first alternative embodiment thereof;

FIG. 7 is a side elevational view thereof;

FIG. 8 is a bottom plan view thereof;

FIG. 9 is a front elevational view thereof;

FIG. 10 is a rear elevational view thereof;

FIG. 11 is an overhead plan view similar to FIG. 1 but showing a second alternative embodiment thereof;

FIG. 12 is a side elevational view thereof;

FIG. 13 is a bottom plan view thereof;

FIG. 14 is a front elevational view thereof;

FIG. 15 is a rear elevational view thereof;

FIG. 16 is an overhead plan view similar to FIG. 1 but showing a third alternative embodiment thereof;

FIG. 17 is a side elevational view thereof;

FIG. 18 is a bottom plan view thereof;

FIG. 19 is a front elevational view thereof; and,

FIG. 20 is a rear elevational view thereof.

The side elevational view of each respective embodiment which is not shown in the drawings is a mirror image of the side view thereof, which is shown.

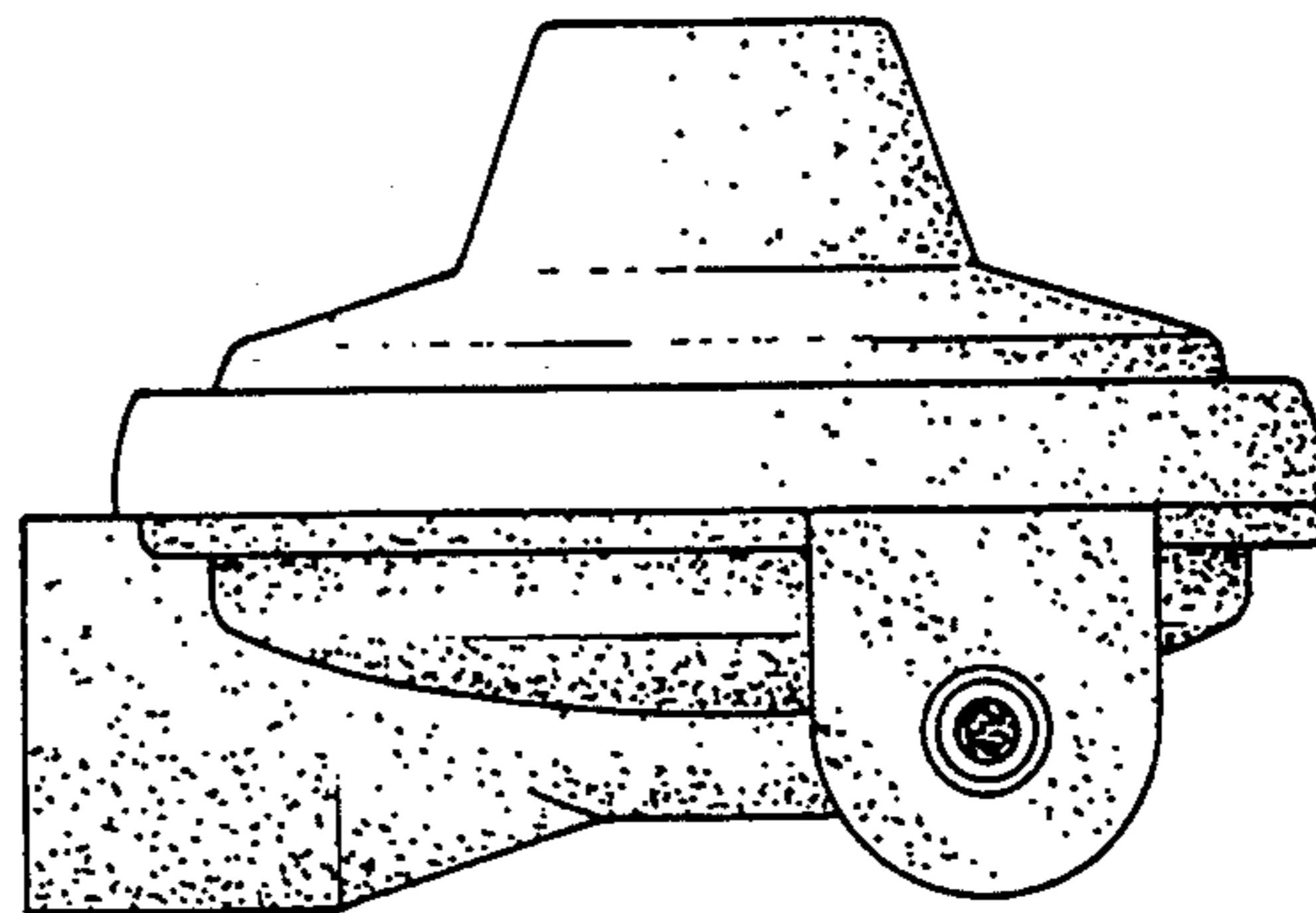
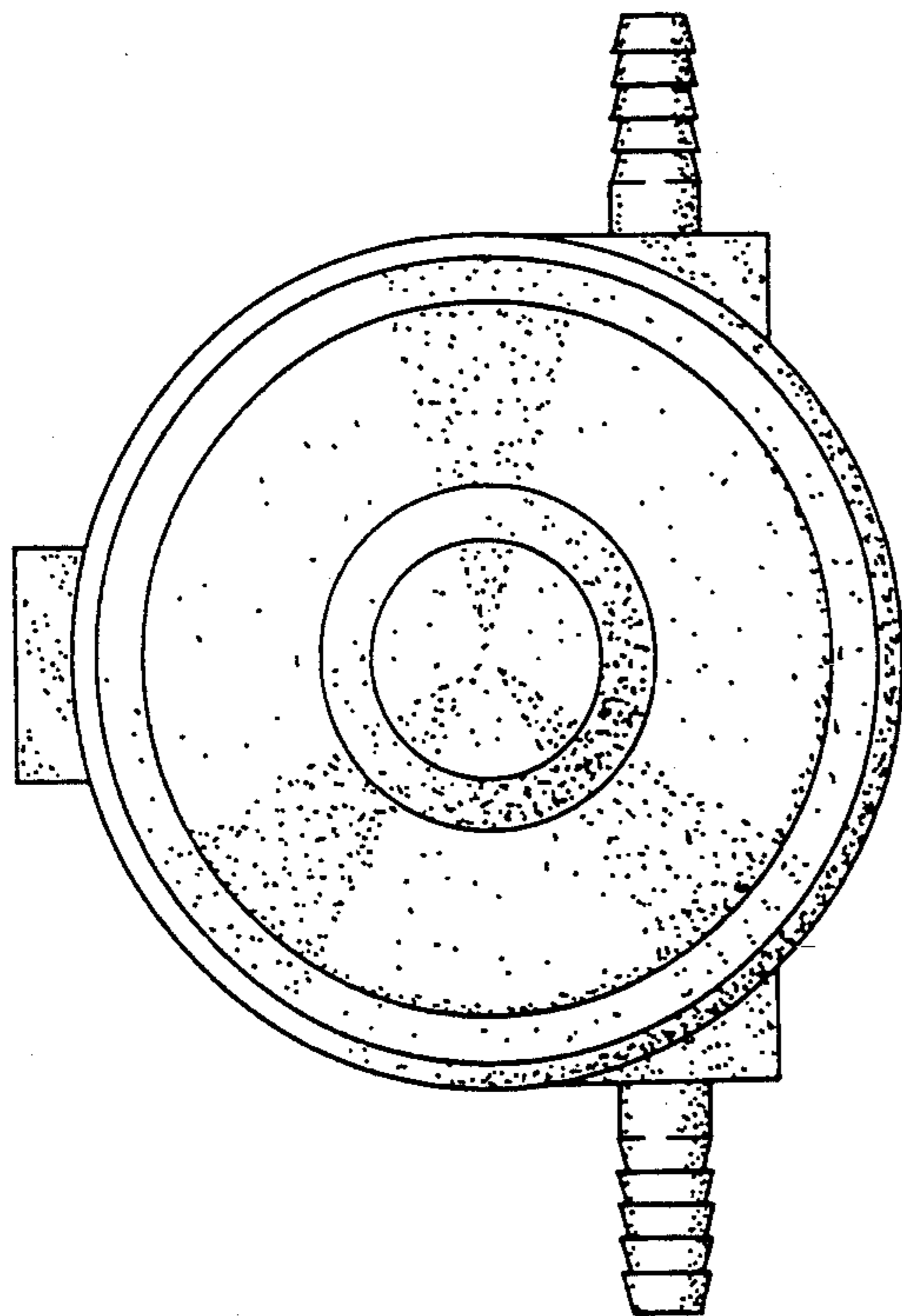

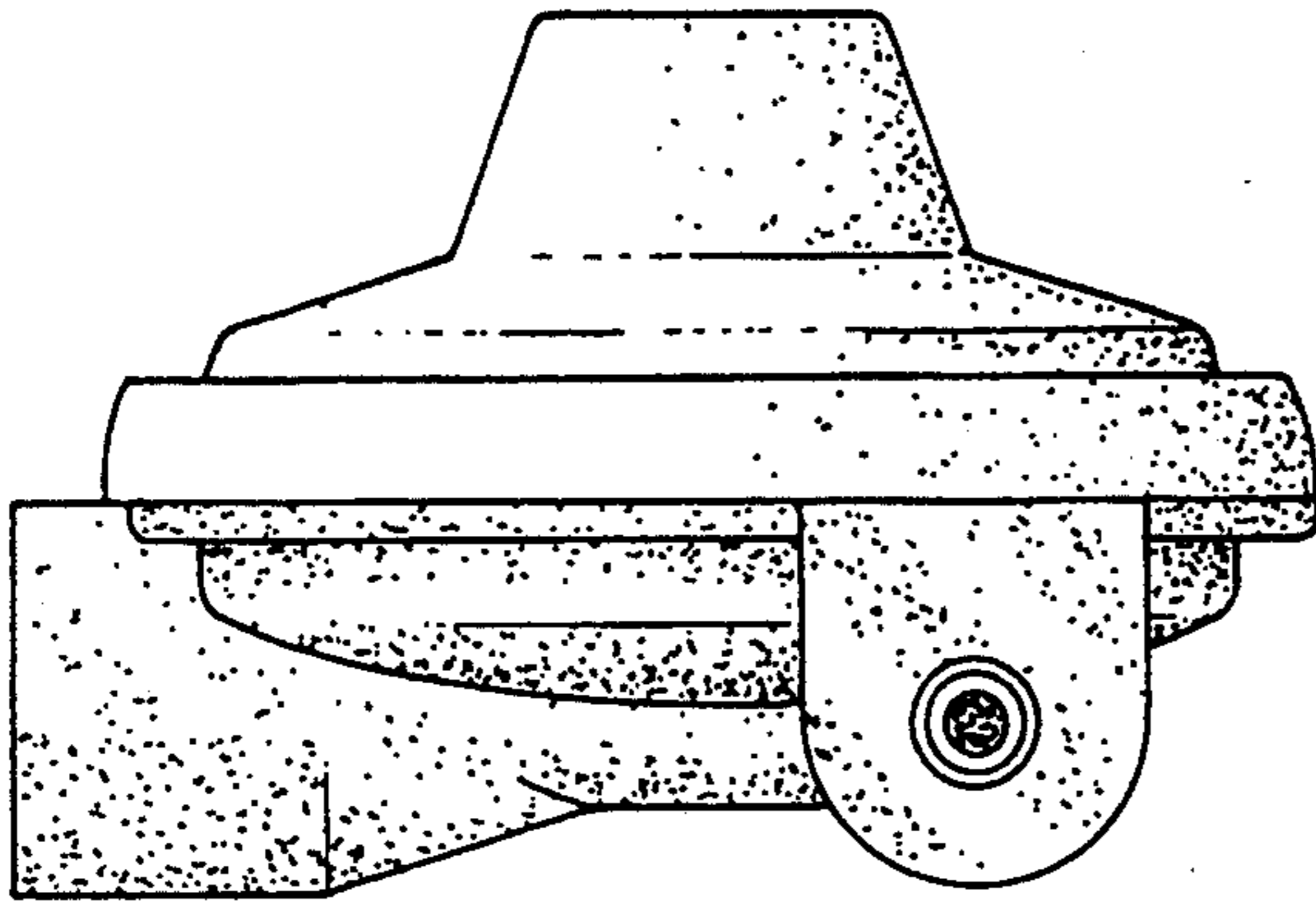

FIG. 2

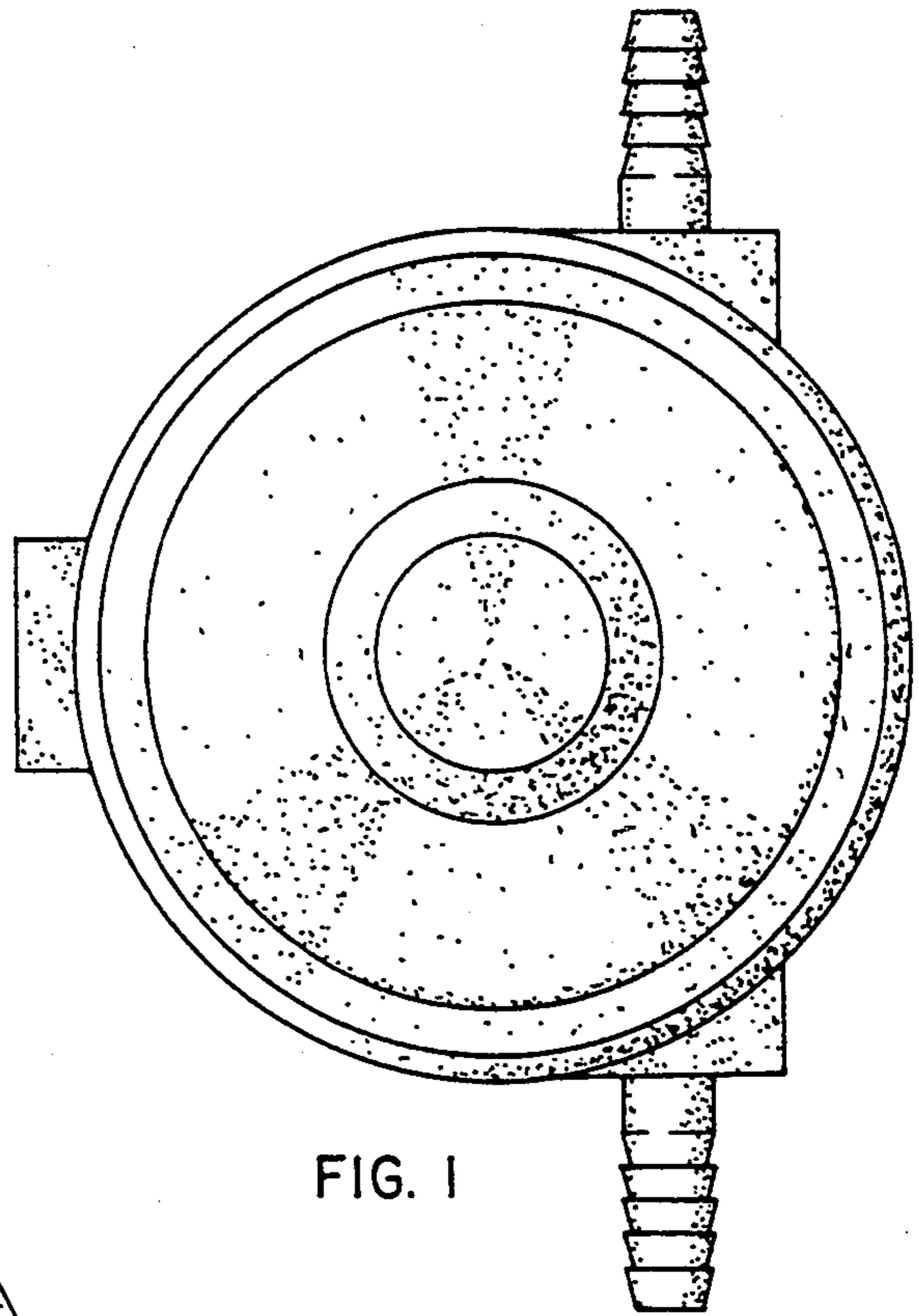

FIG. 1

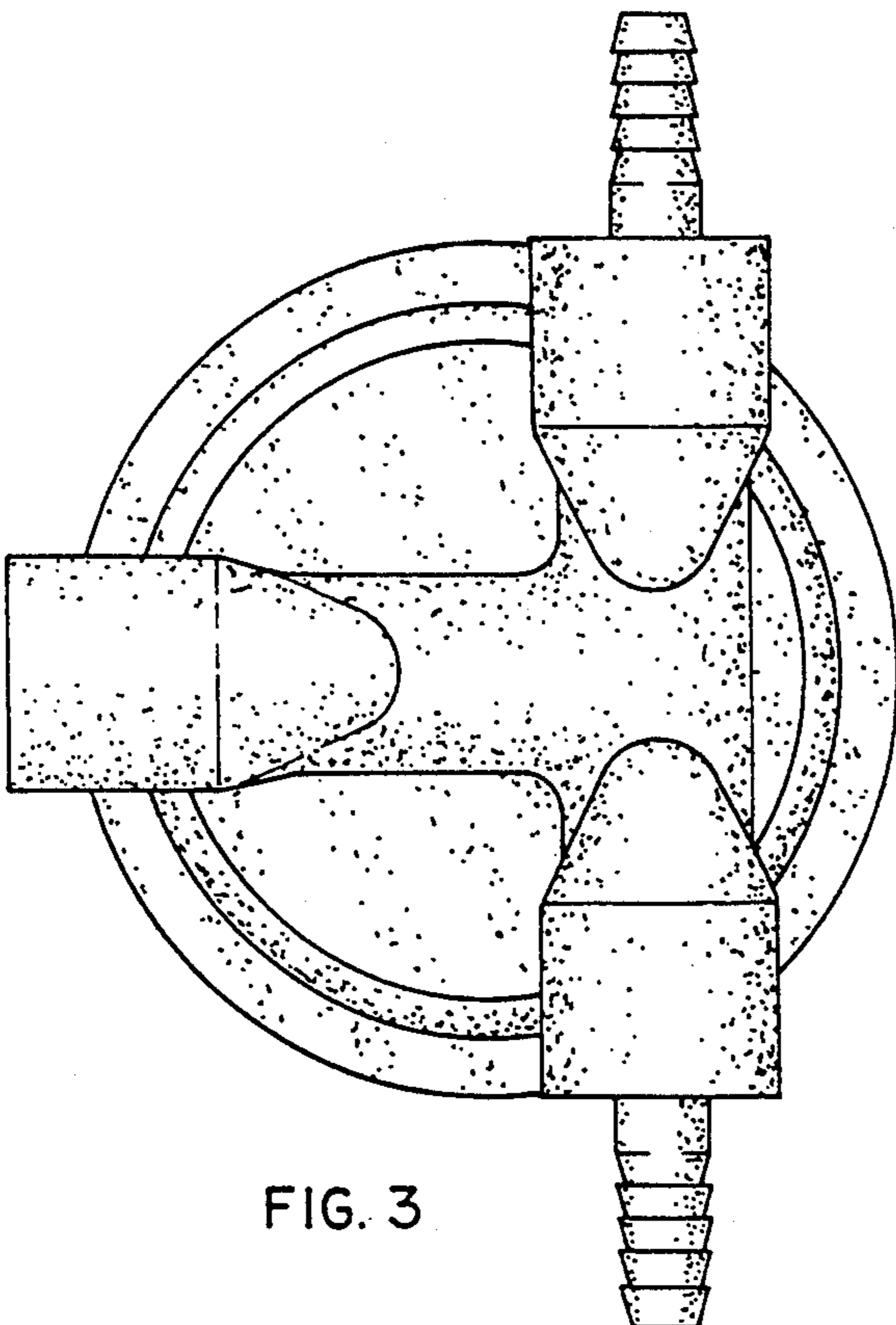

FIG. 3

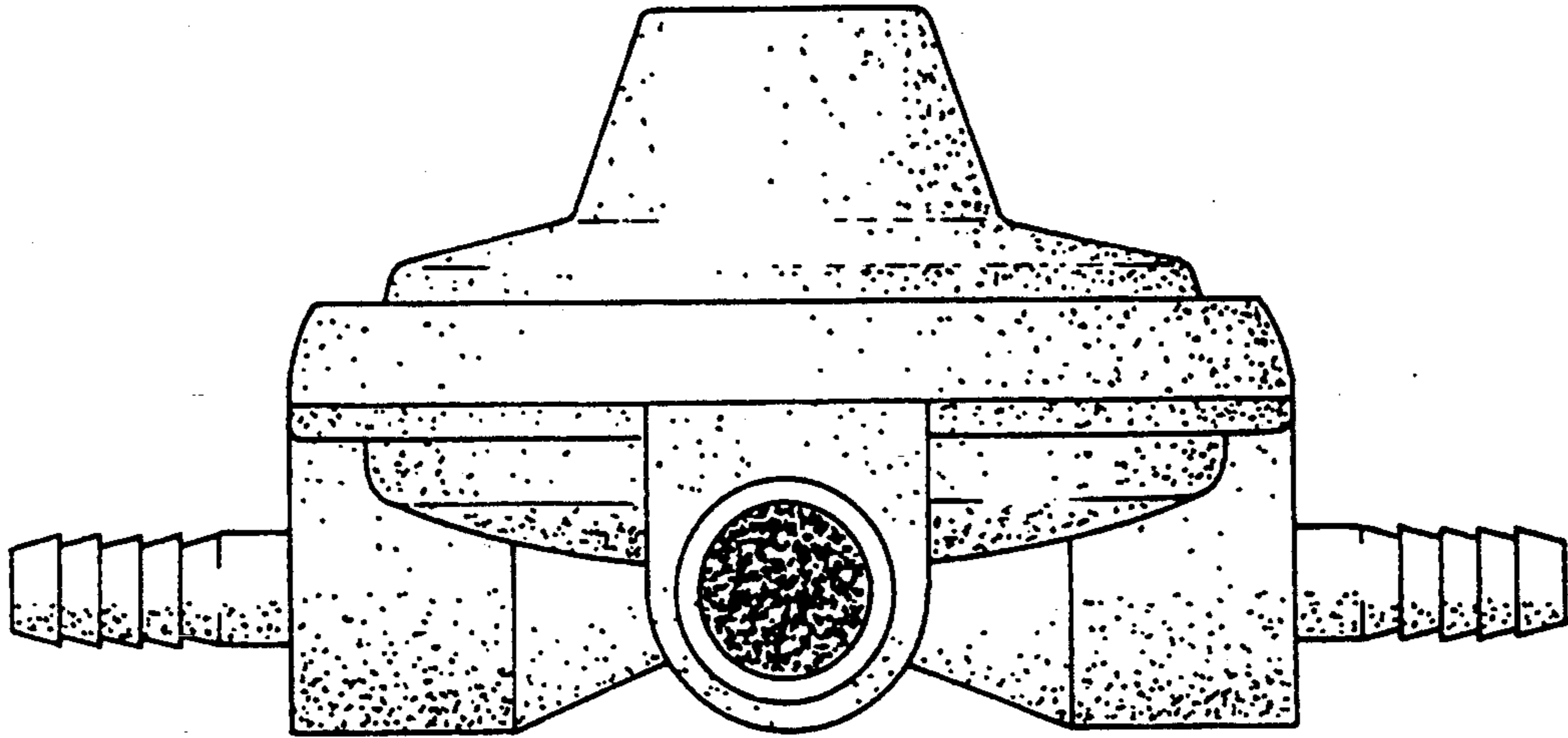

FIG. 4

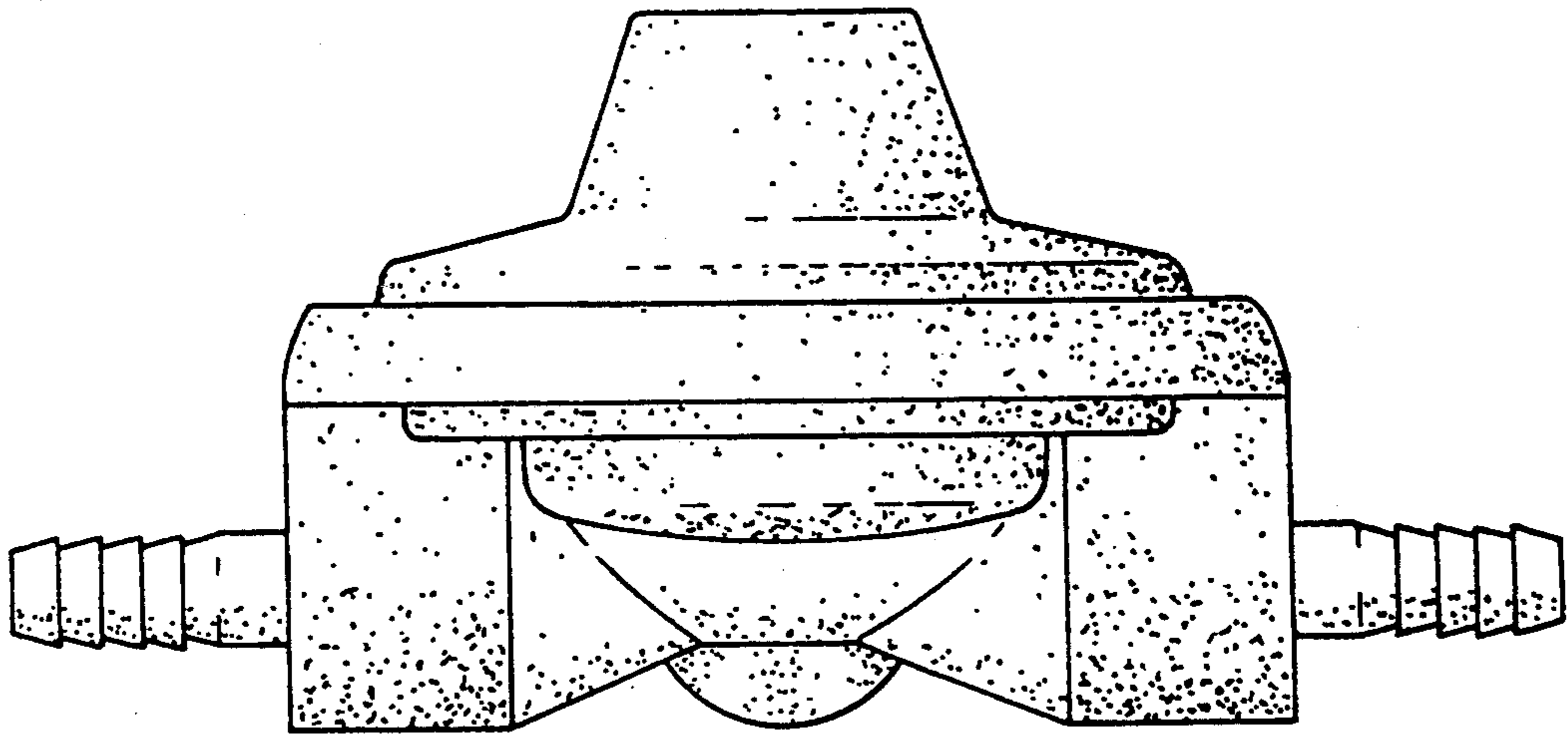

FIG. 5

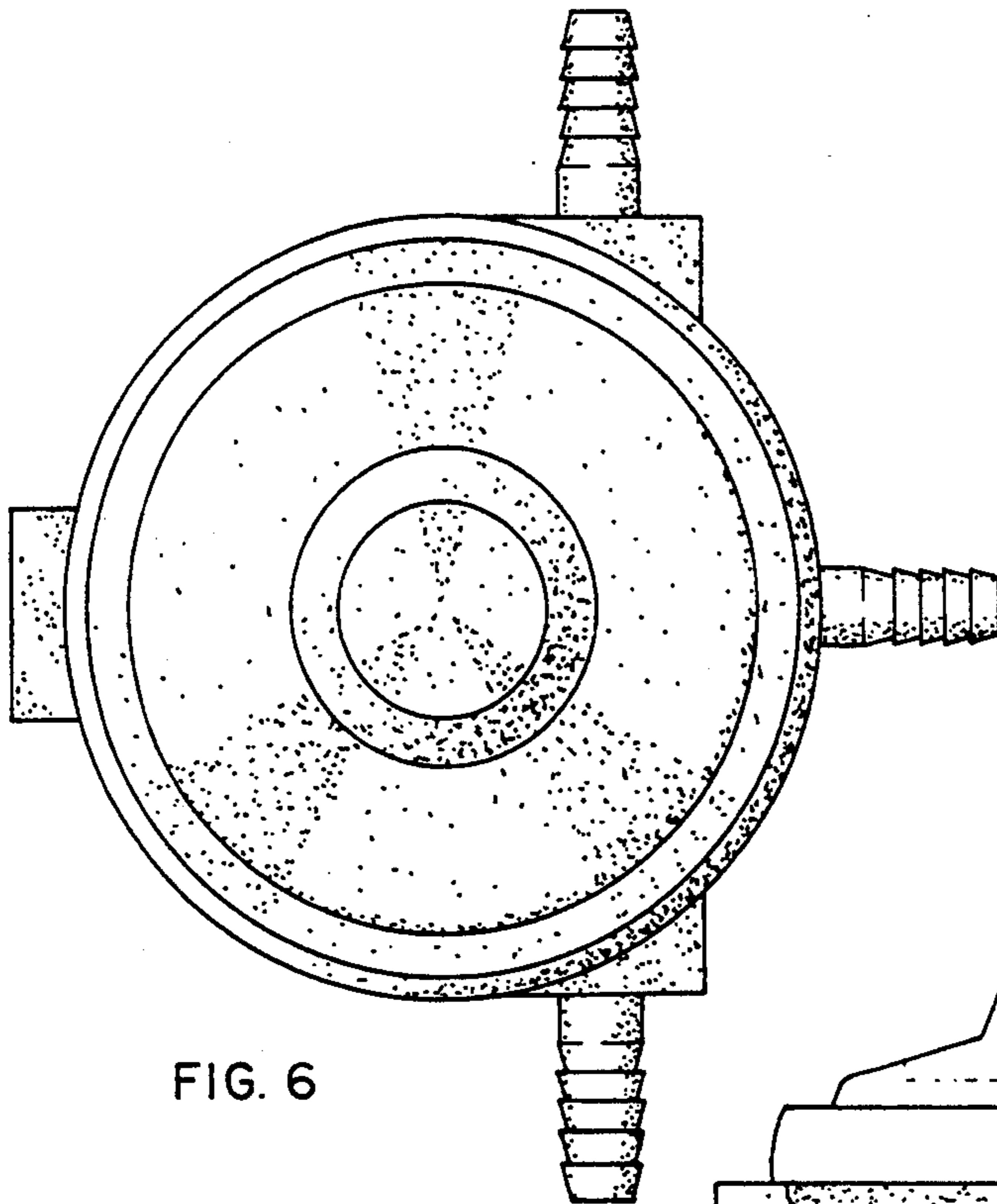

FIG. 6

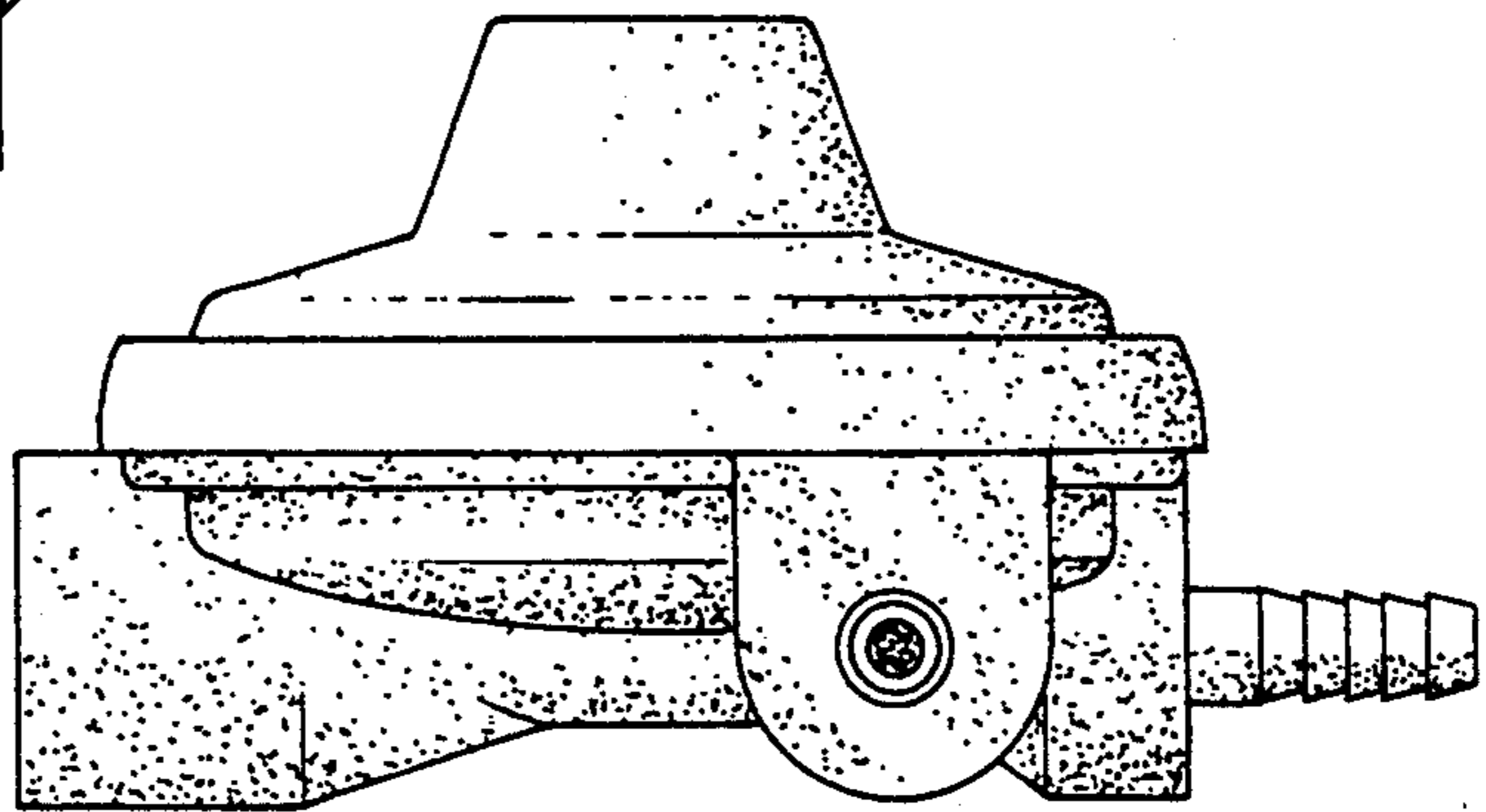

FIG. 7

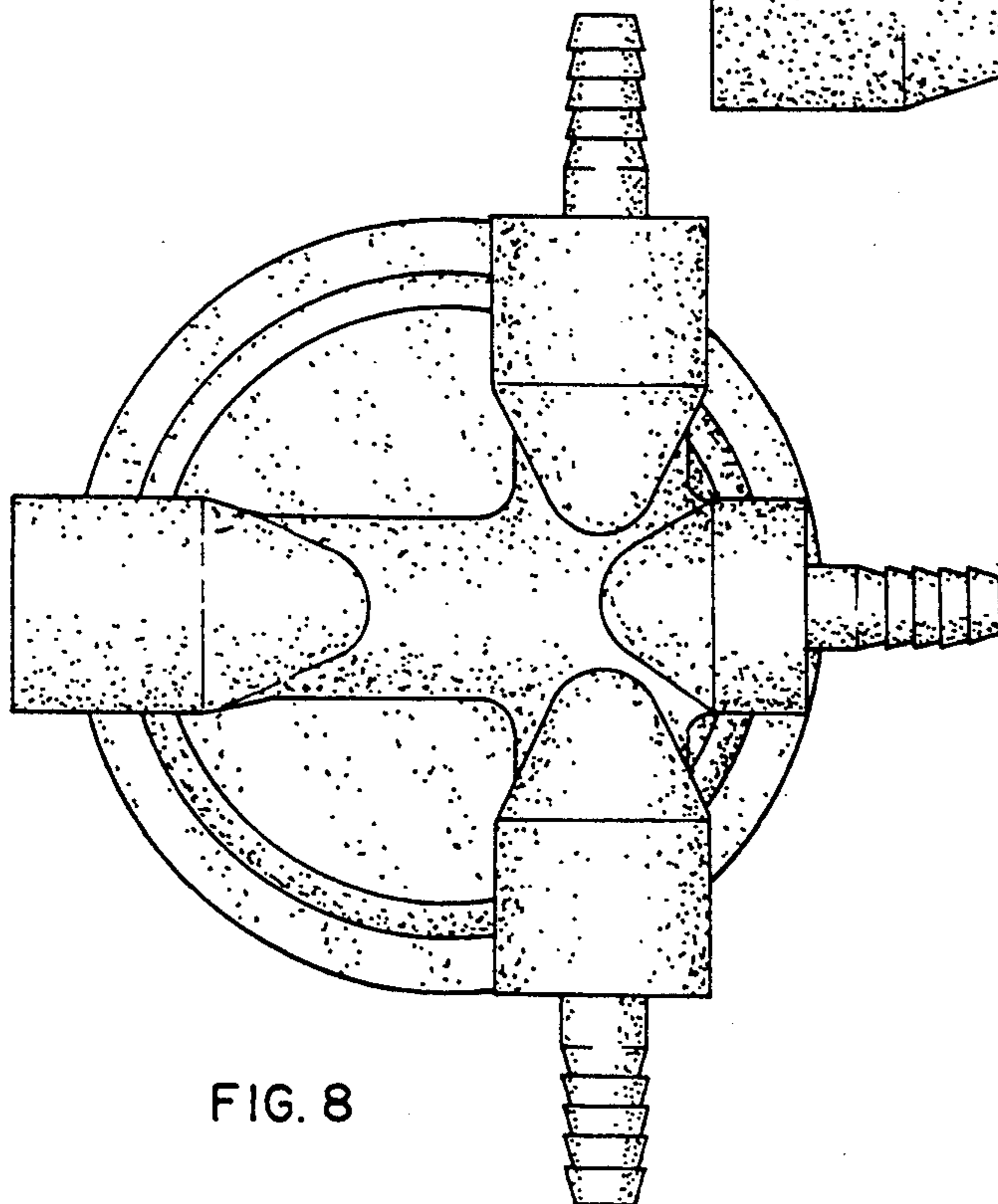

FIG. 8

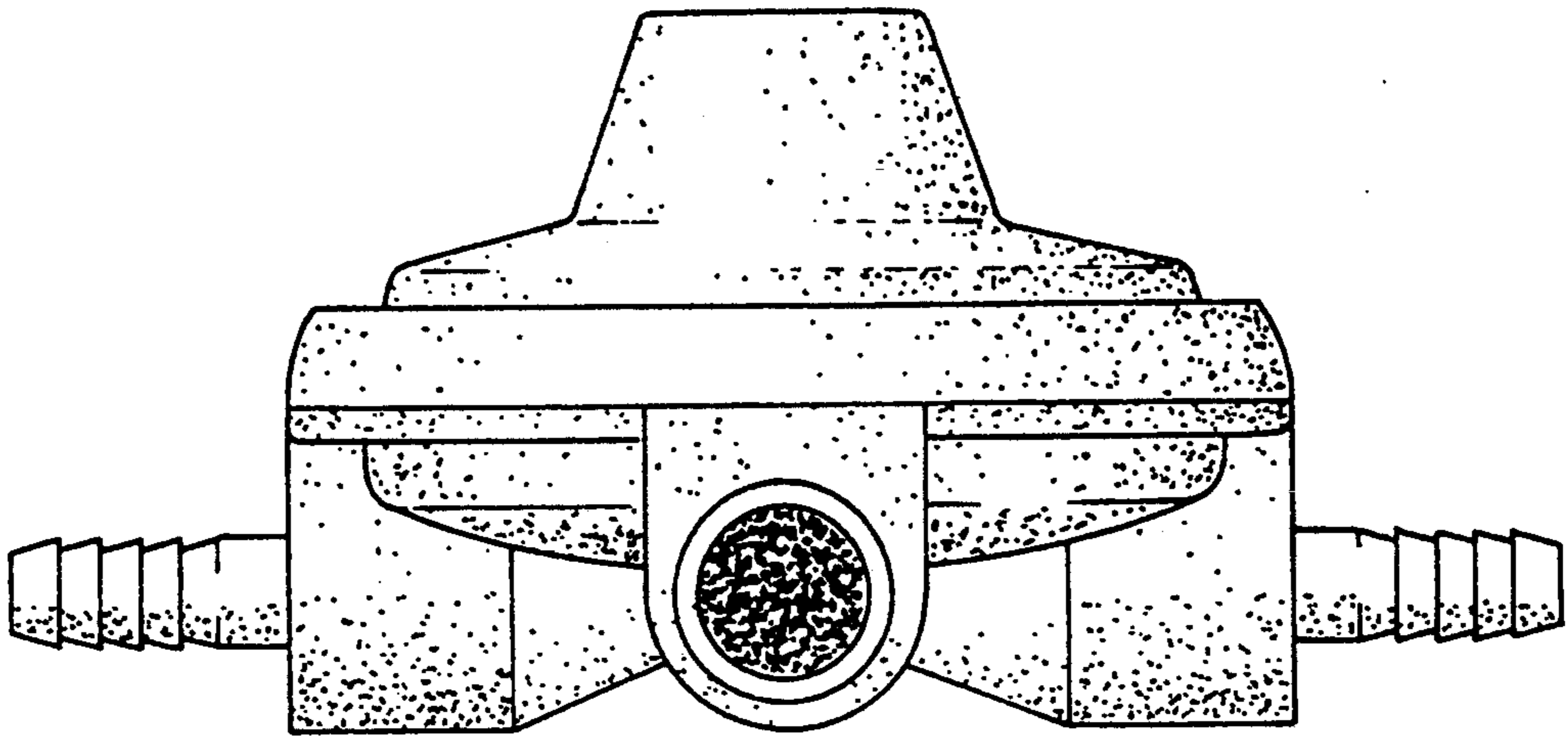

FIG. 9

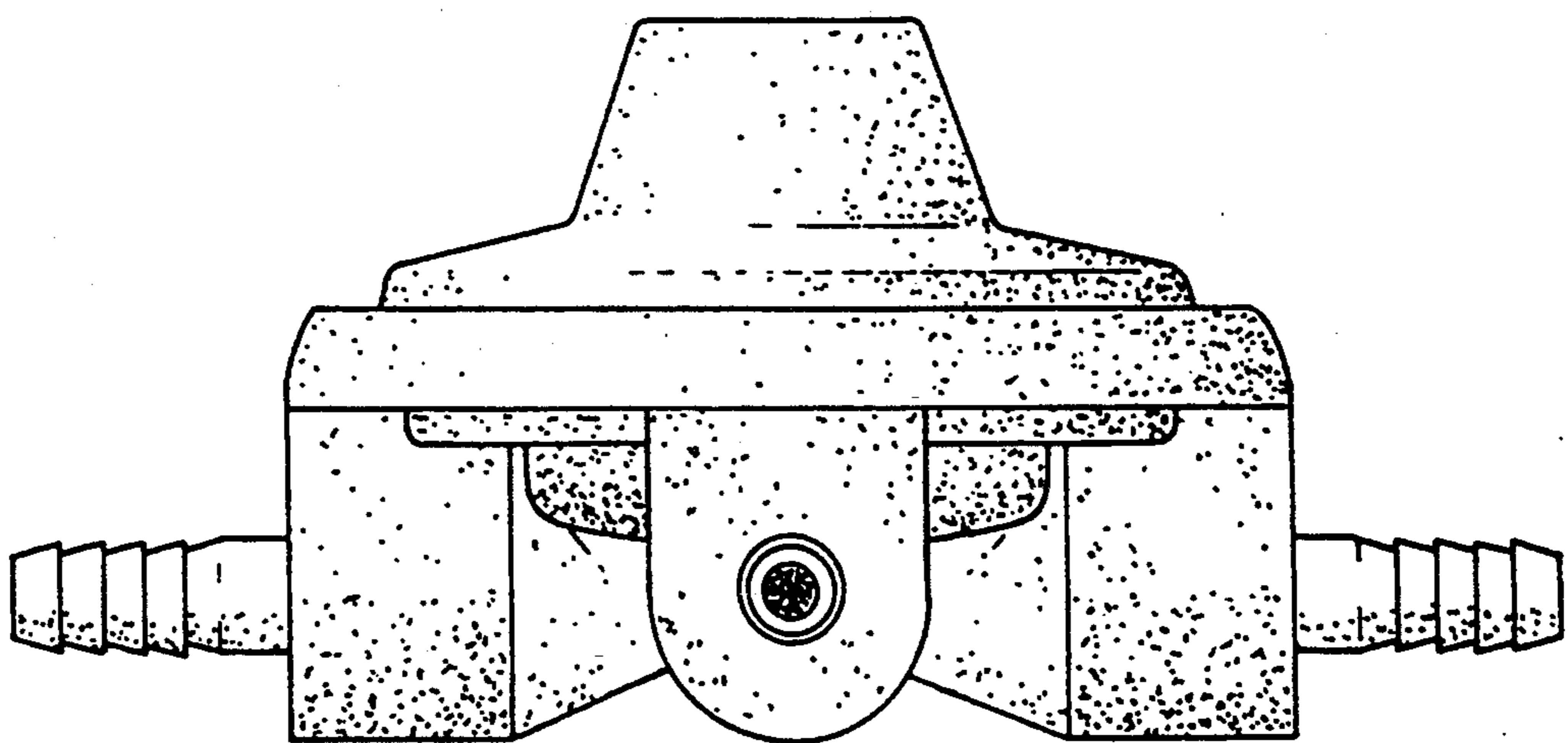

FIG. 10

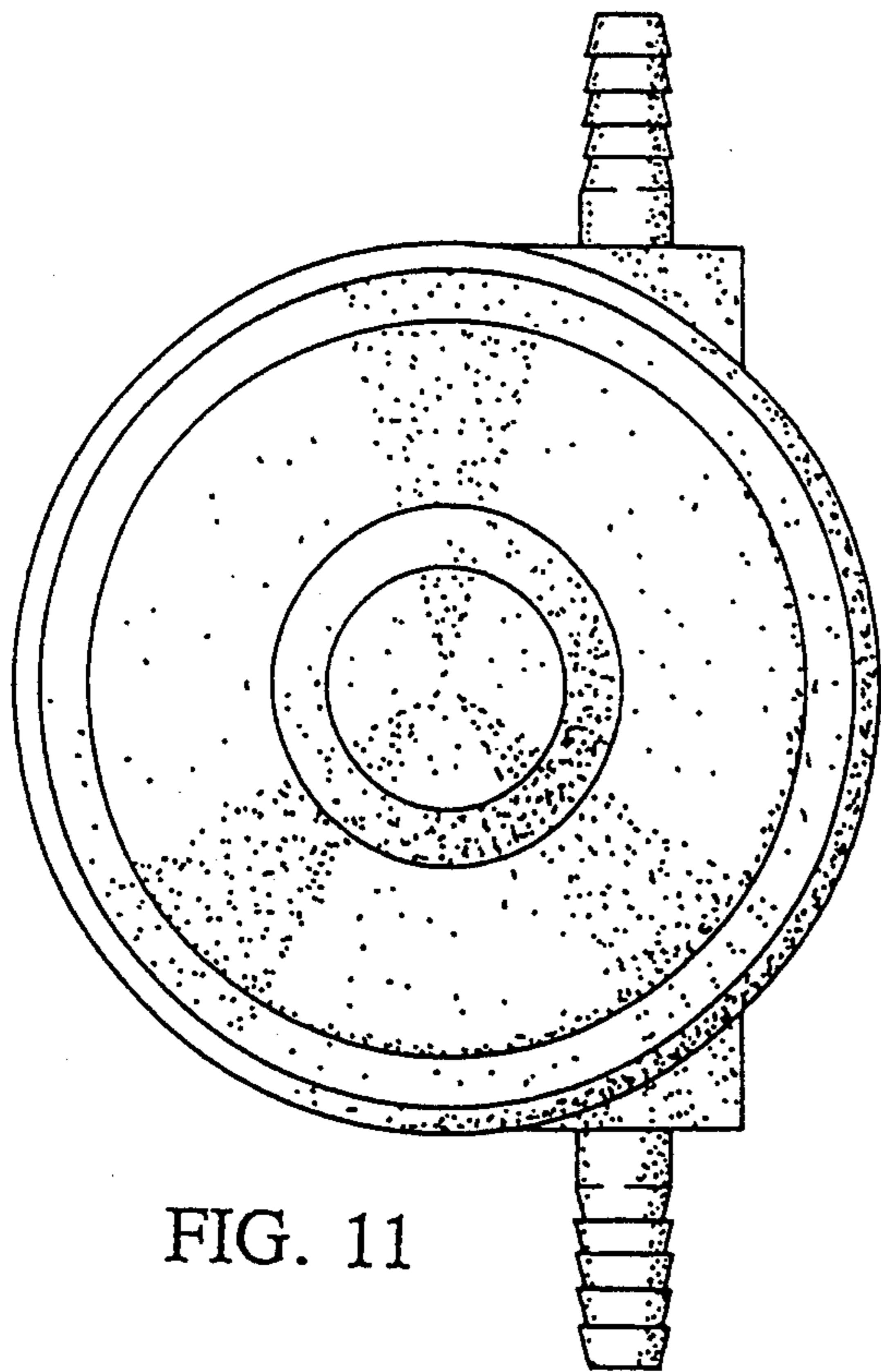

FIG. 11

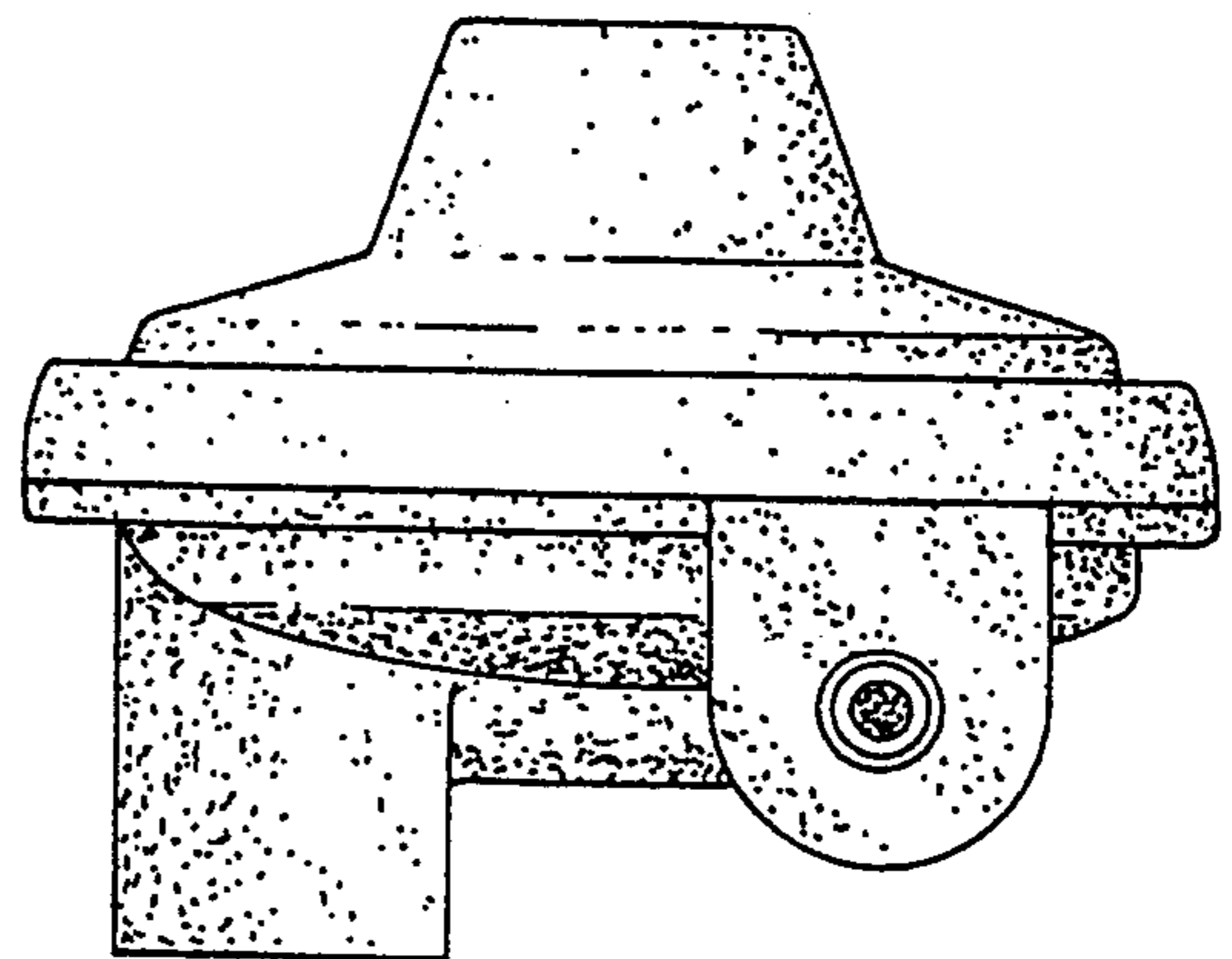

FIG. 12

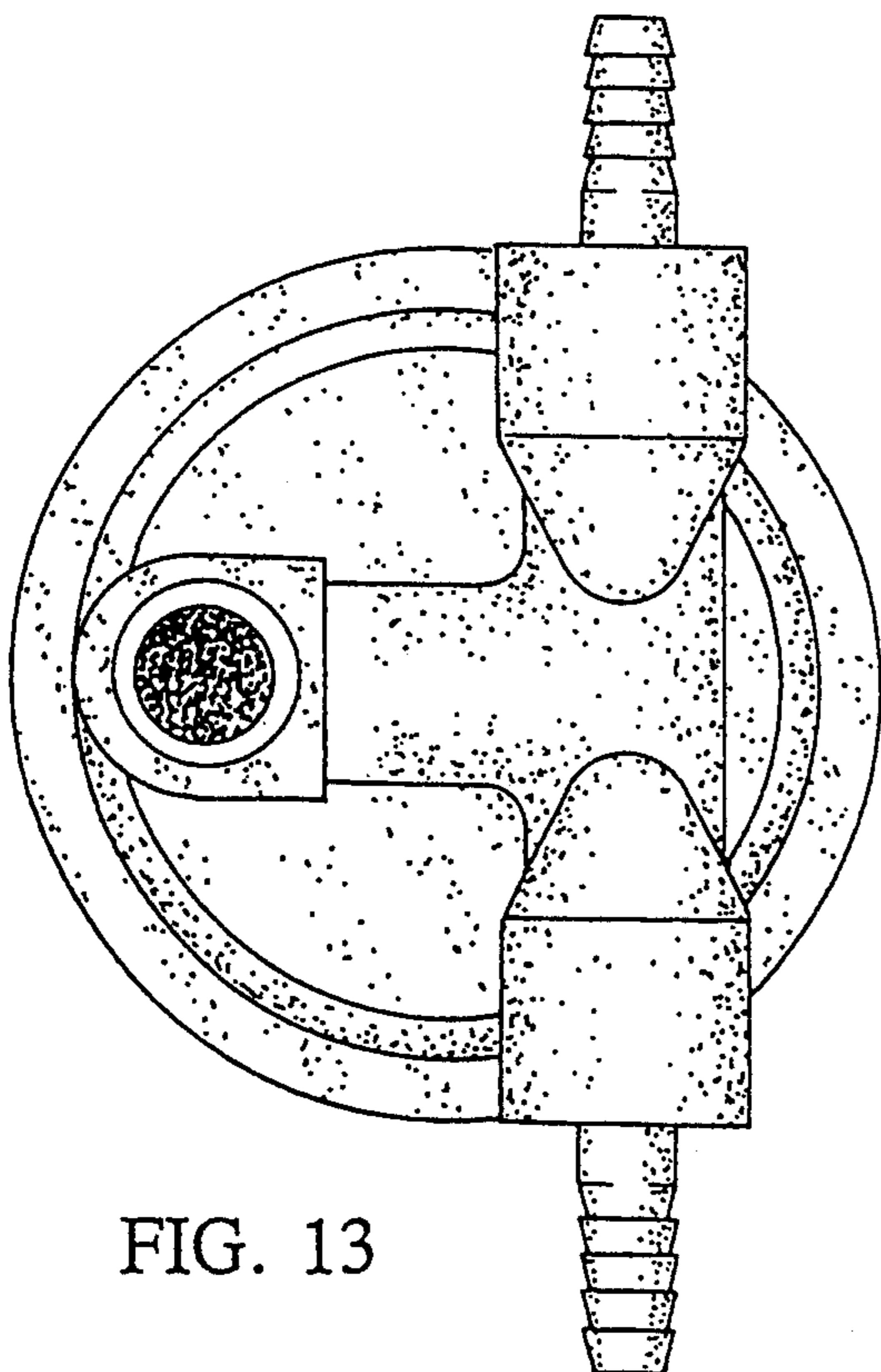

FIG. 13

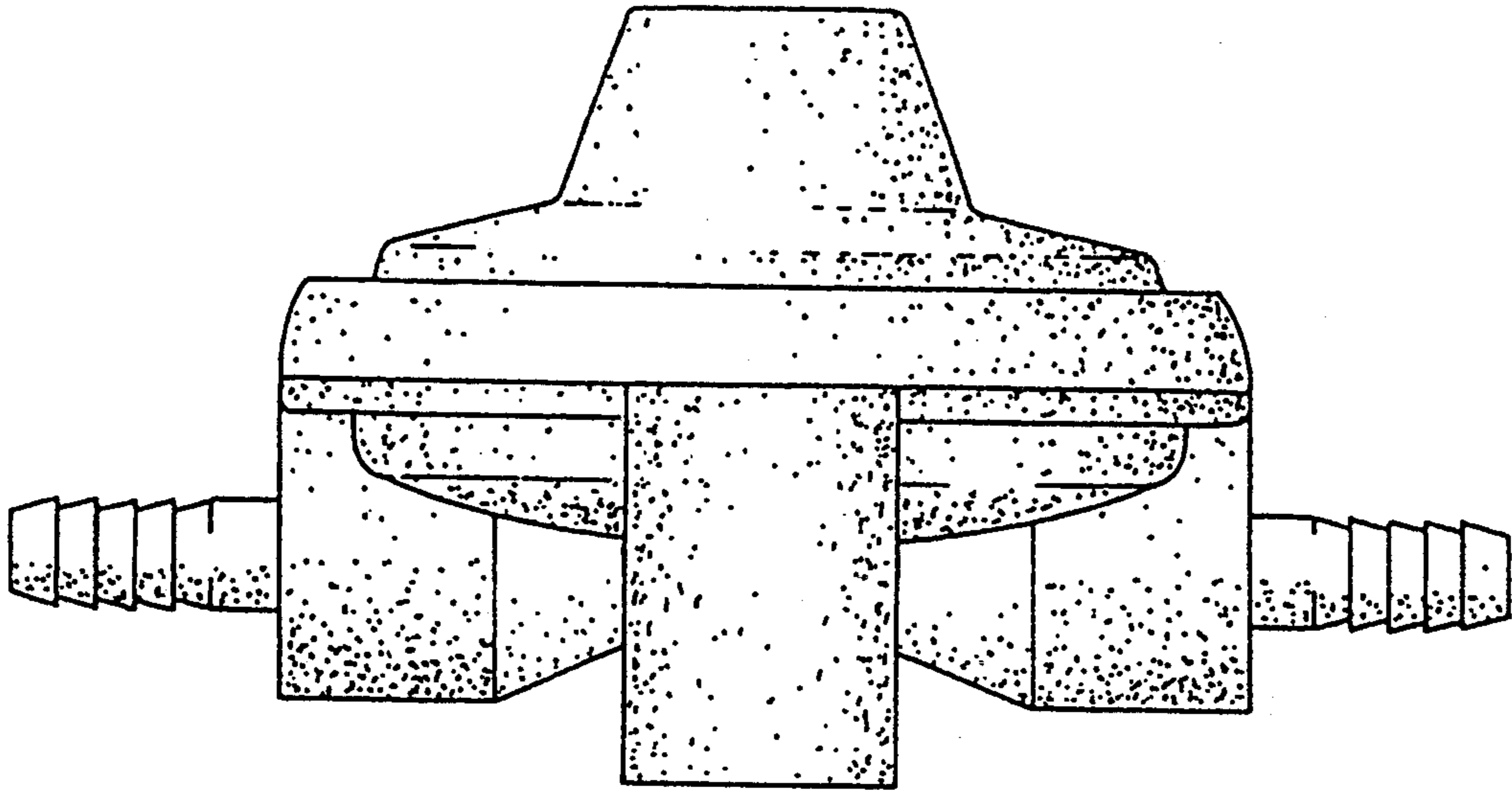

FIG. 14

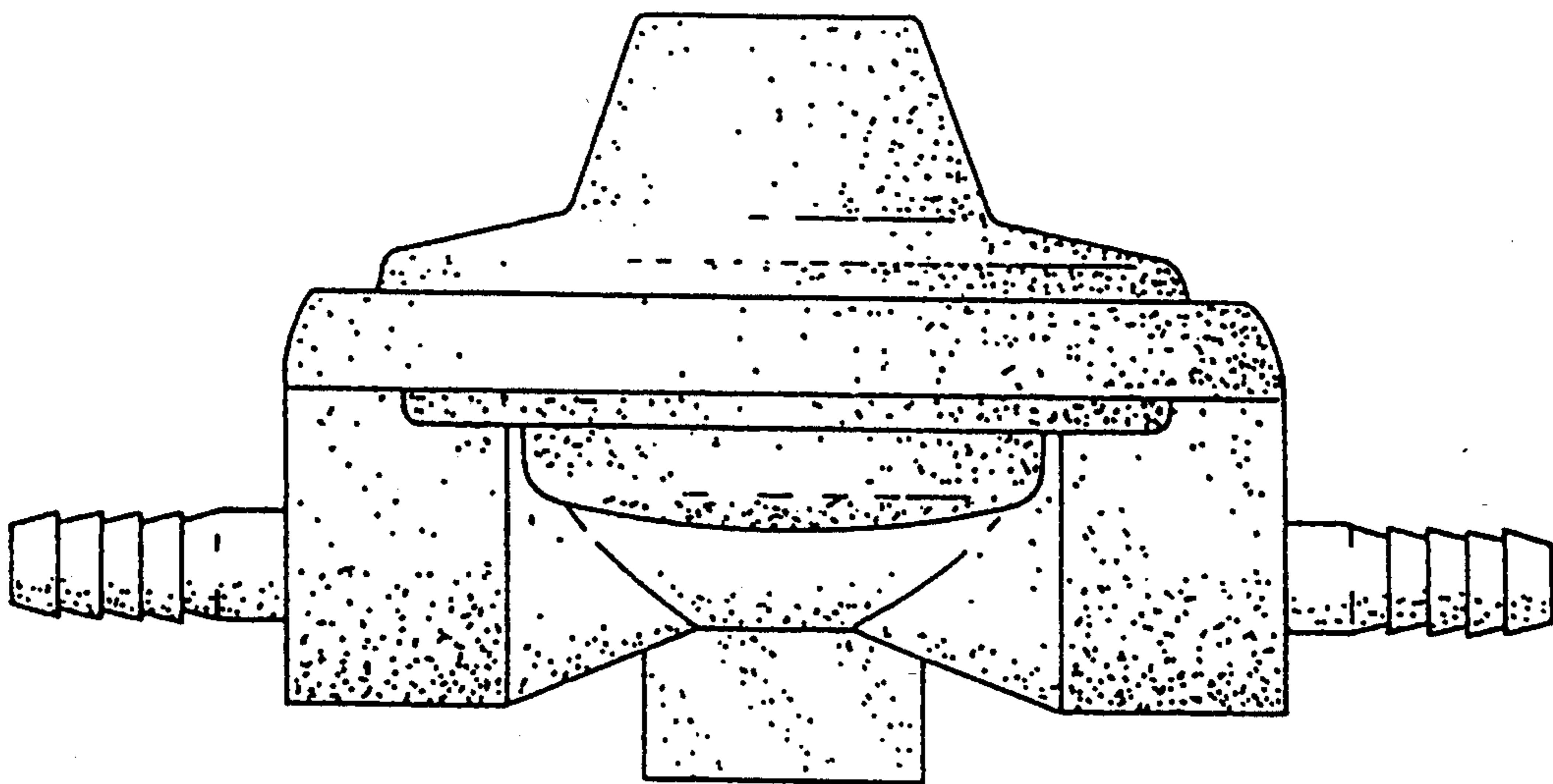

FIG. 15

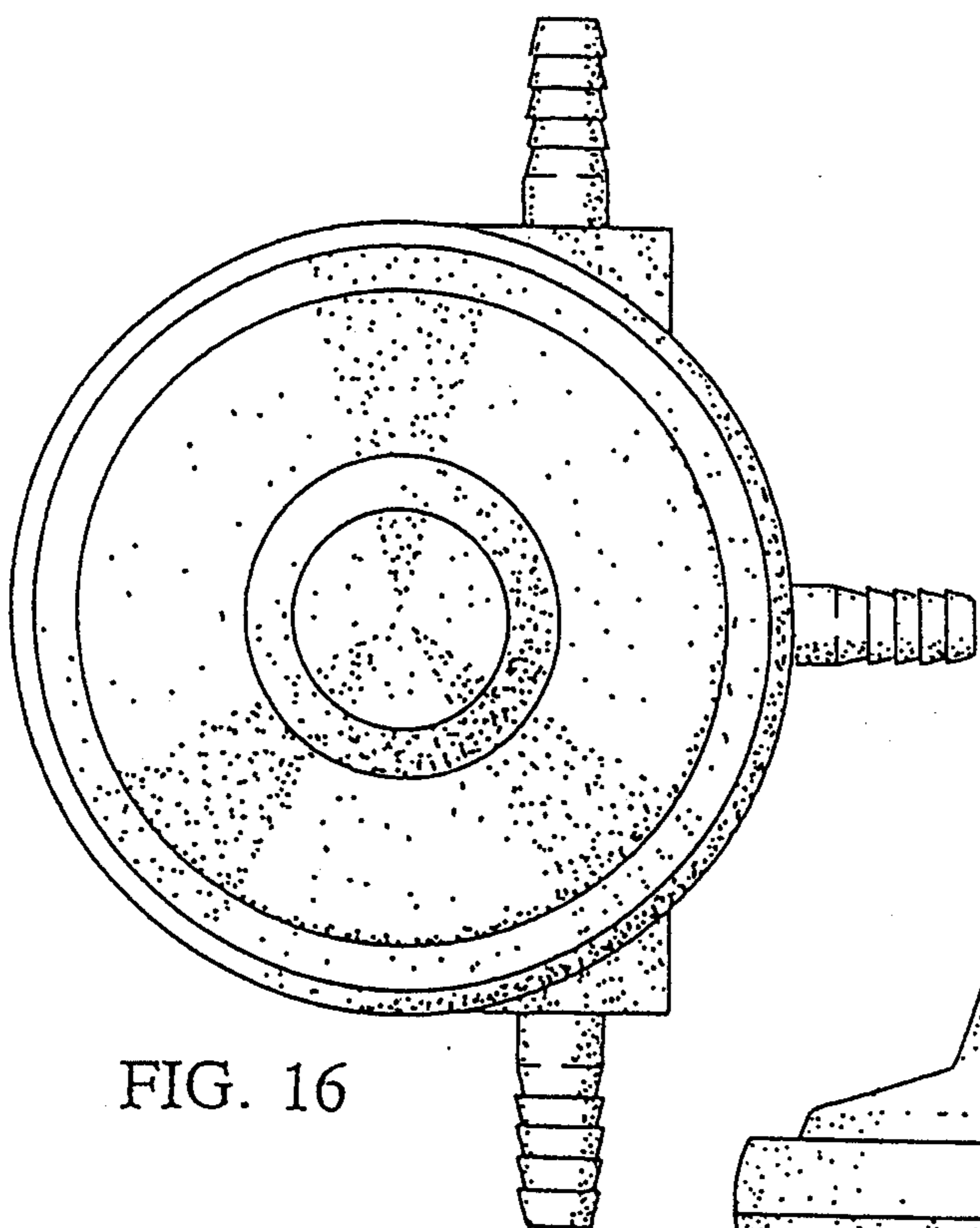

FIG. 16

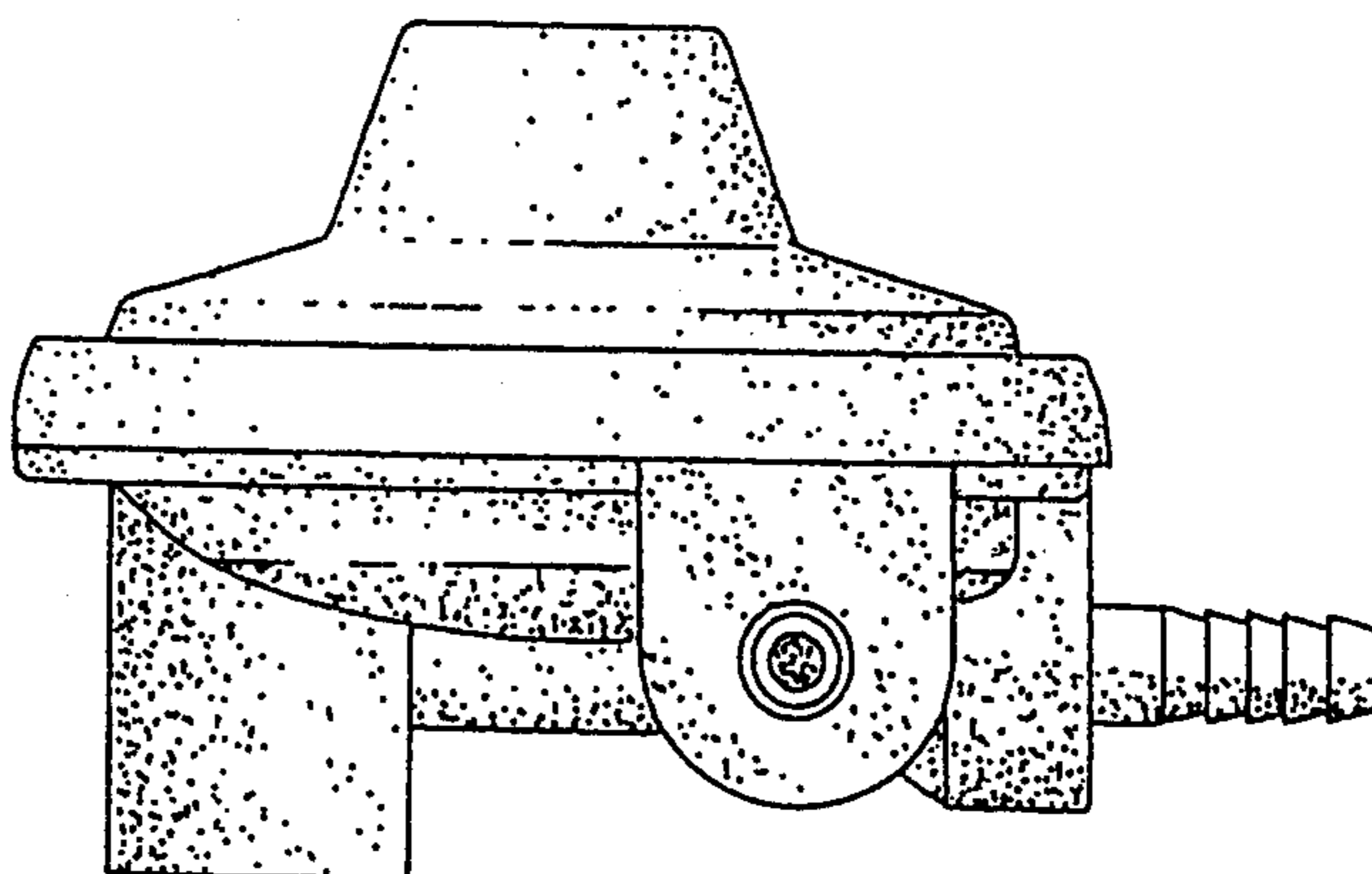

FIG. 17

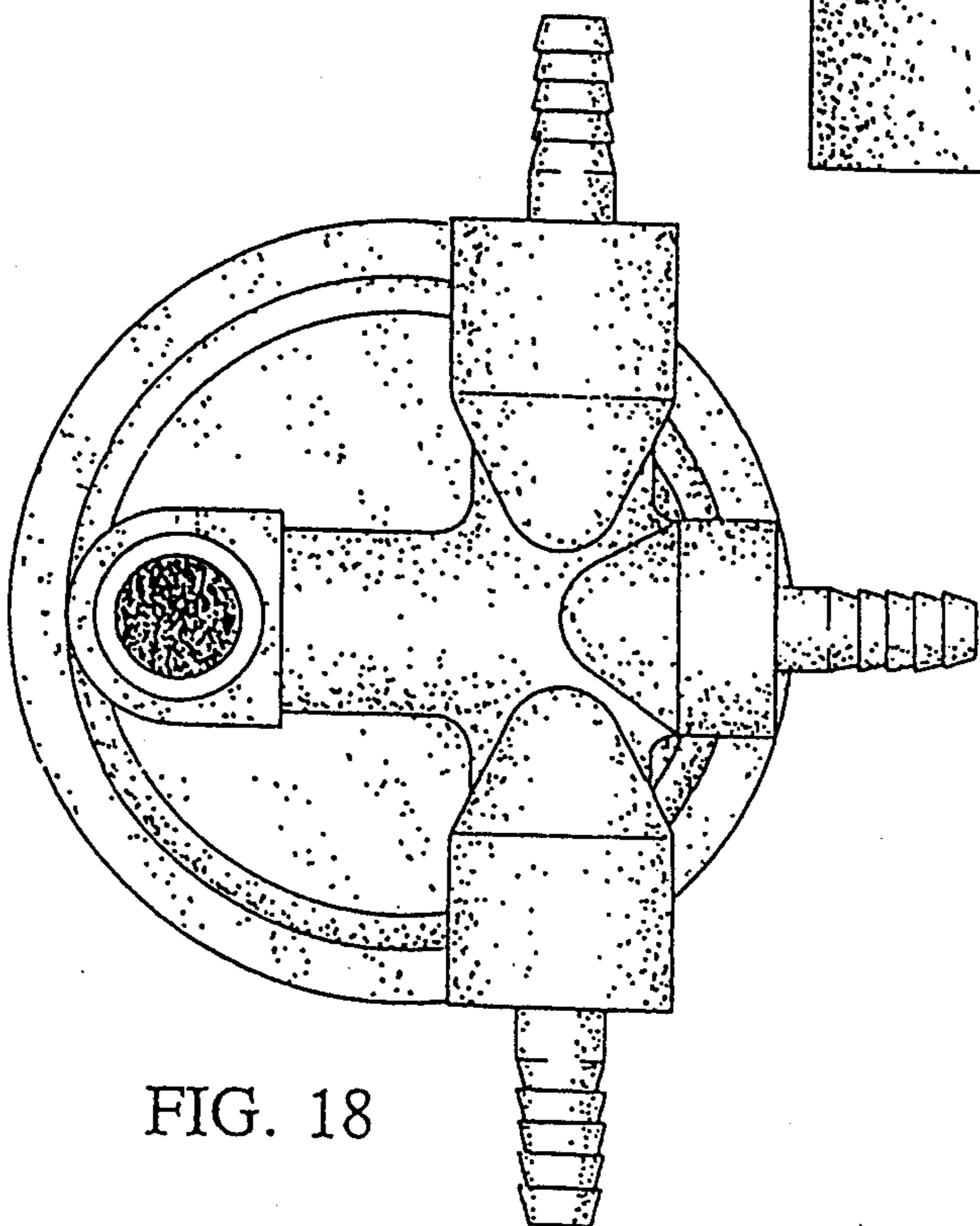

FIG. 18

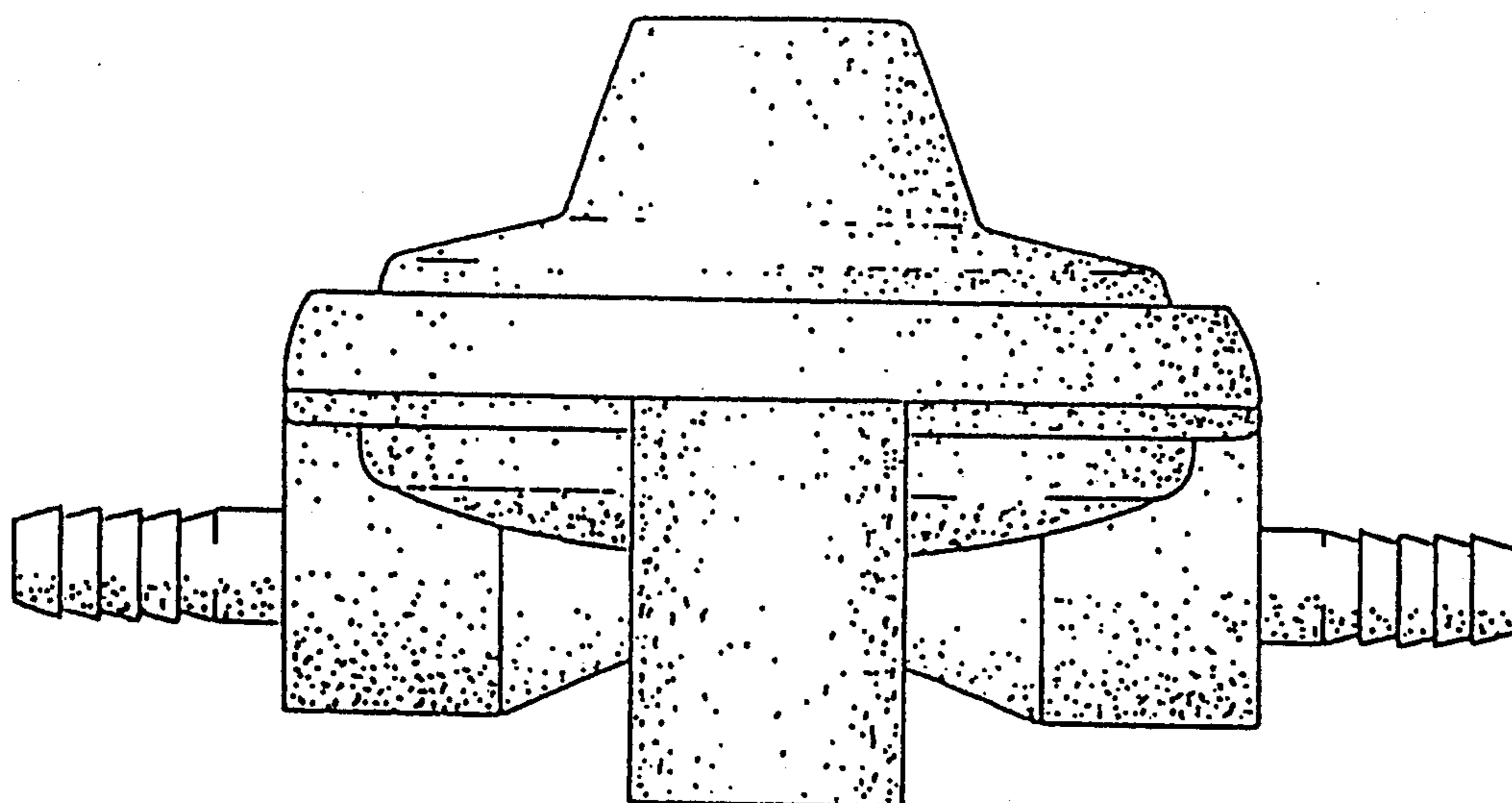

FIG. 19

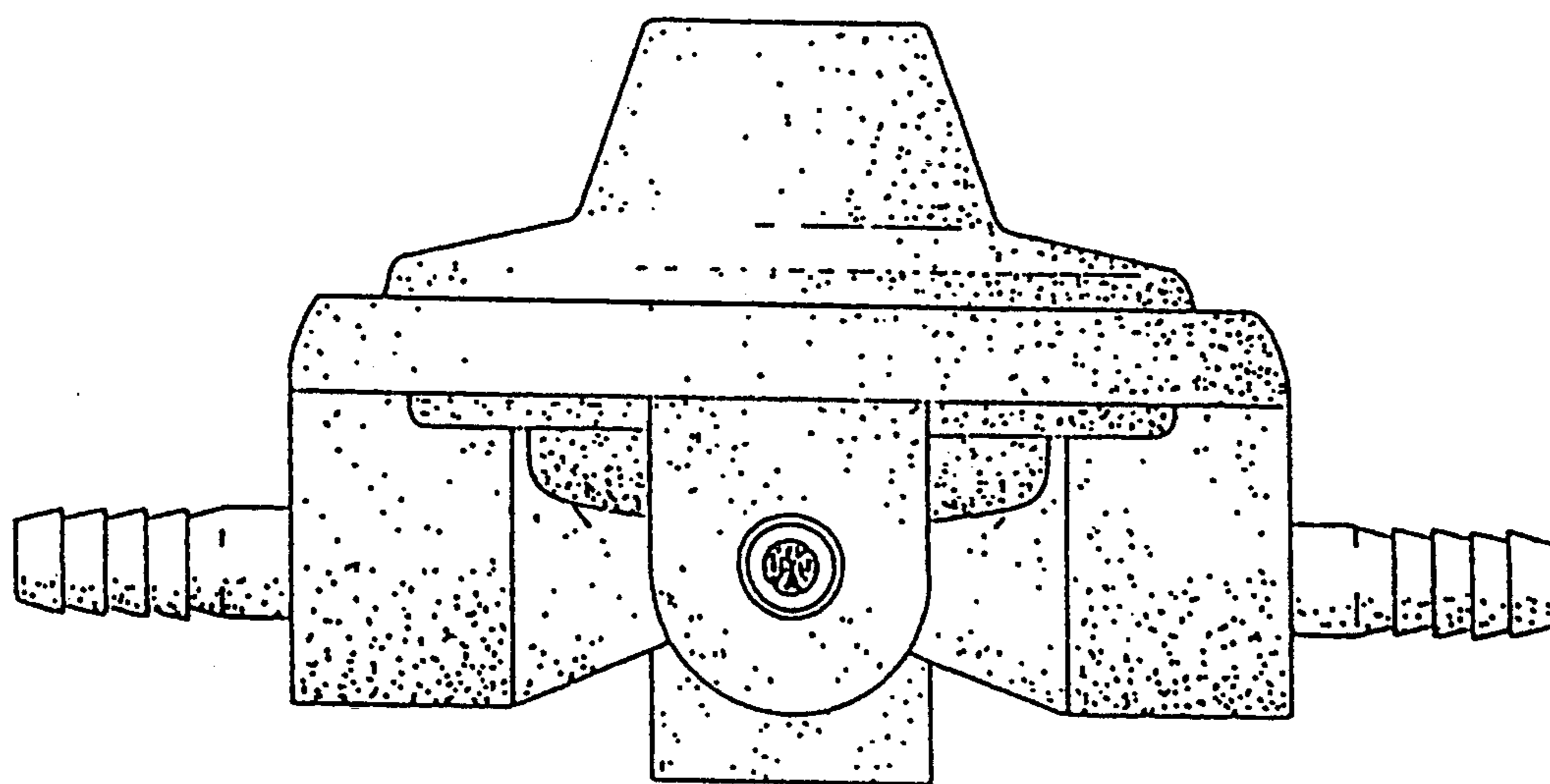

FIG. 20