



US00D362126S

United States Patent [19]

[11] Patent Number: **Des. 362,126**

Carter

[45] Date of Patent: **** Sep. 12, 1995**

[54] **VEHICLE SEAT**

[75] Inventor: **Raymond Carter**, Marina del Ray, Calif.

[73] Assignee: **Grammer AG**, Amberg, Germany

[**] Term: **14 Years**

[21] Appl. No.: **24,674**

[22] Filed: **Jun. 20, 1994**

[30] **Foreign Application Priority Data**

Jan. 14, 1994 [DE] Germany M9400221.5

[52] U.S. Cl. **D6/356; D6/367**

[58] Field of Search D6/334, 356, 366, 367, D6/368, 374, 375, 500, 501, 502; 297/344.1, 373, 452.25

[56] **References Cited**

U.S. PATENT DOCUMENTS

D. 213,685 4/1969 Barecki D6/356

D. 233,638 11/1974 Offredi D6/366
D. 251,997 6/1979 Pelly D6/356
D. 264,643 6/1982 Pelly D6/366
3,309,138 3/1967 Byczkowski 297/373

Primary Examiner—Alan P. Douglas
Assistant Examiner—Gary D. Watson
Attorney, Agent, or Firm—Hoffmann & Baron

[57] **CLAIM**

The ornamental design for a vehicle seat, as shown and described.

DESCRIPTION

FIG. 1 is a front perspective view of a vehicle seat showing my new design;
FIG. 2 is a top plan view thereof;
FIG. 3 is a right side elevational view thereof;
FIG. 4 is a left side elevational view thereof;
FIG. 5 is a bottom plan view thereof;
FIG. 6 is a front elevational view thereof; and,
FIG. 7 is a back elevational view thereof.

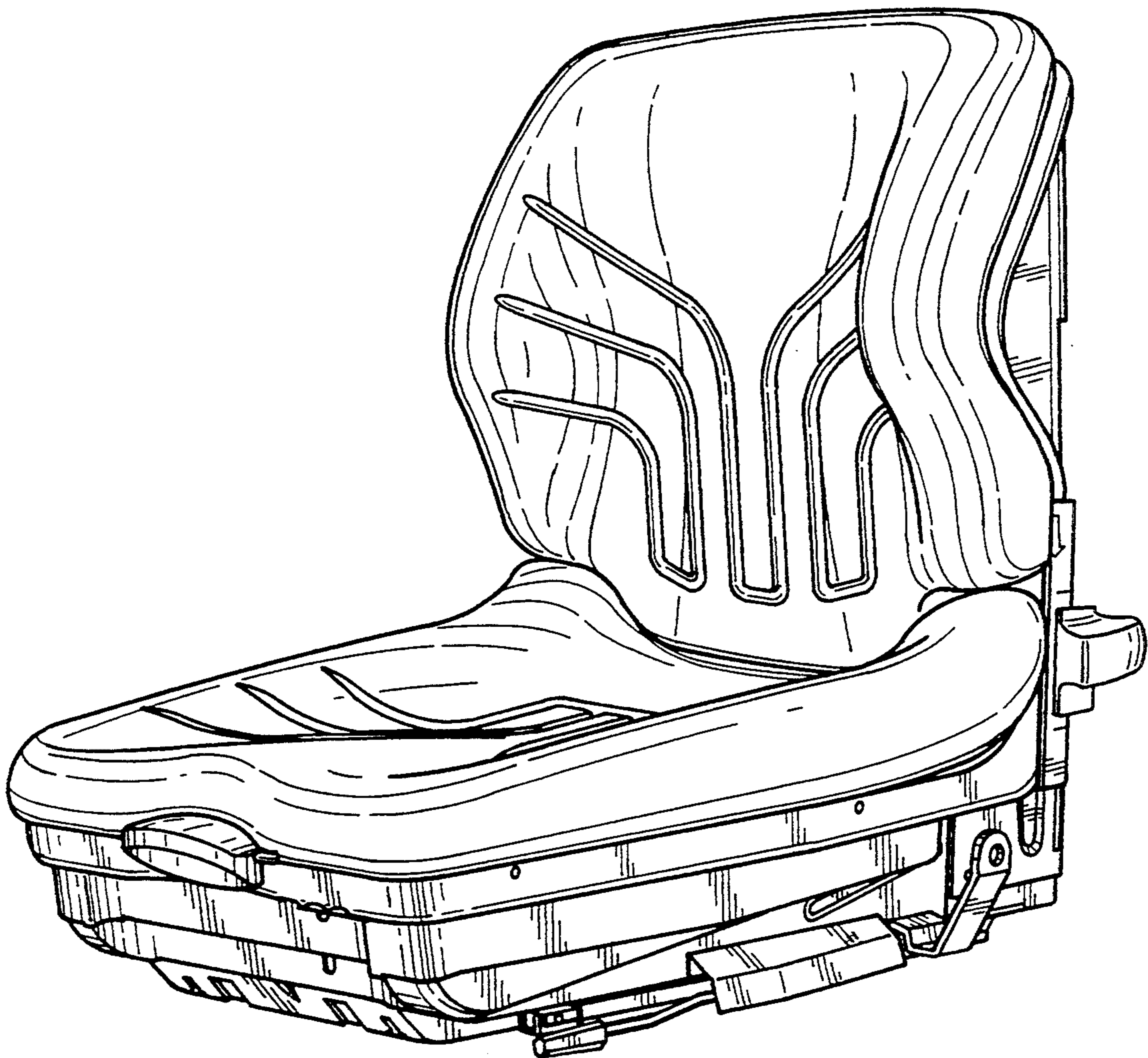
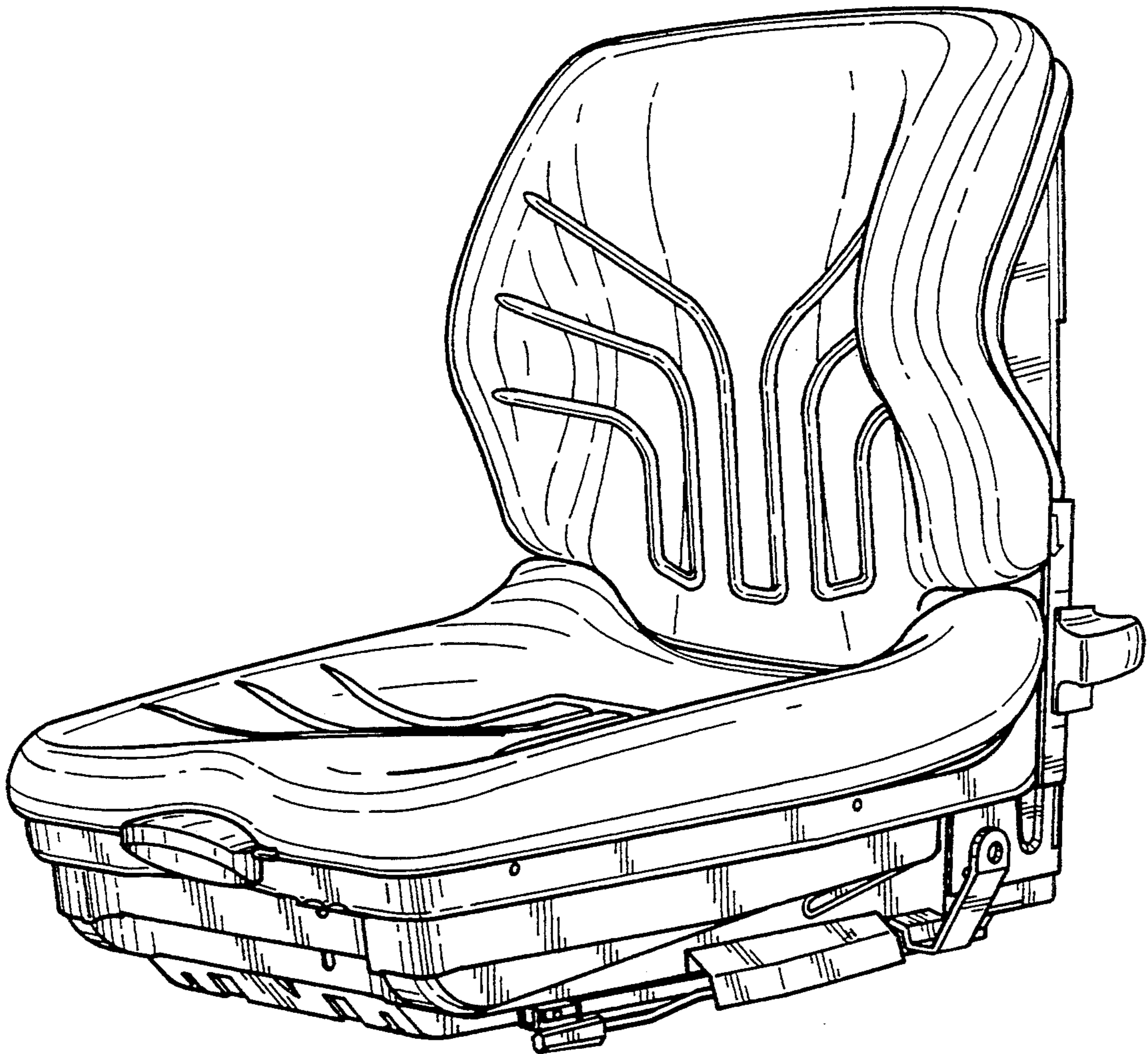

FIG. 1



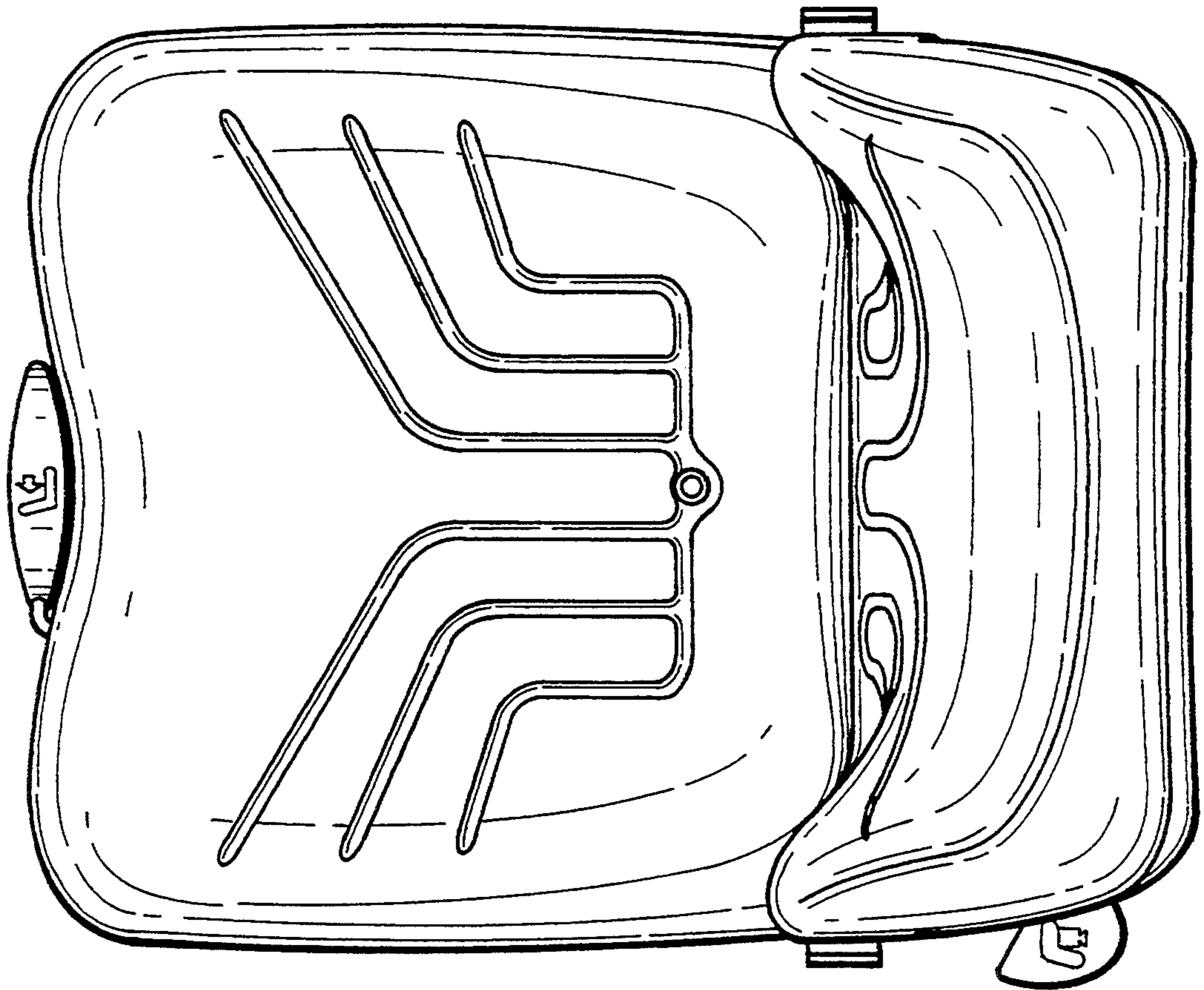

FIG. 2

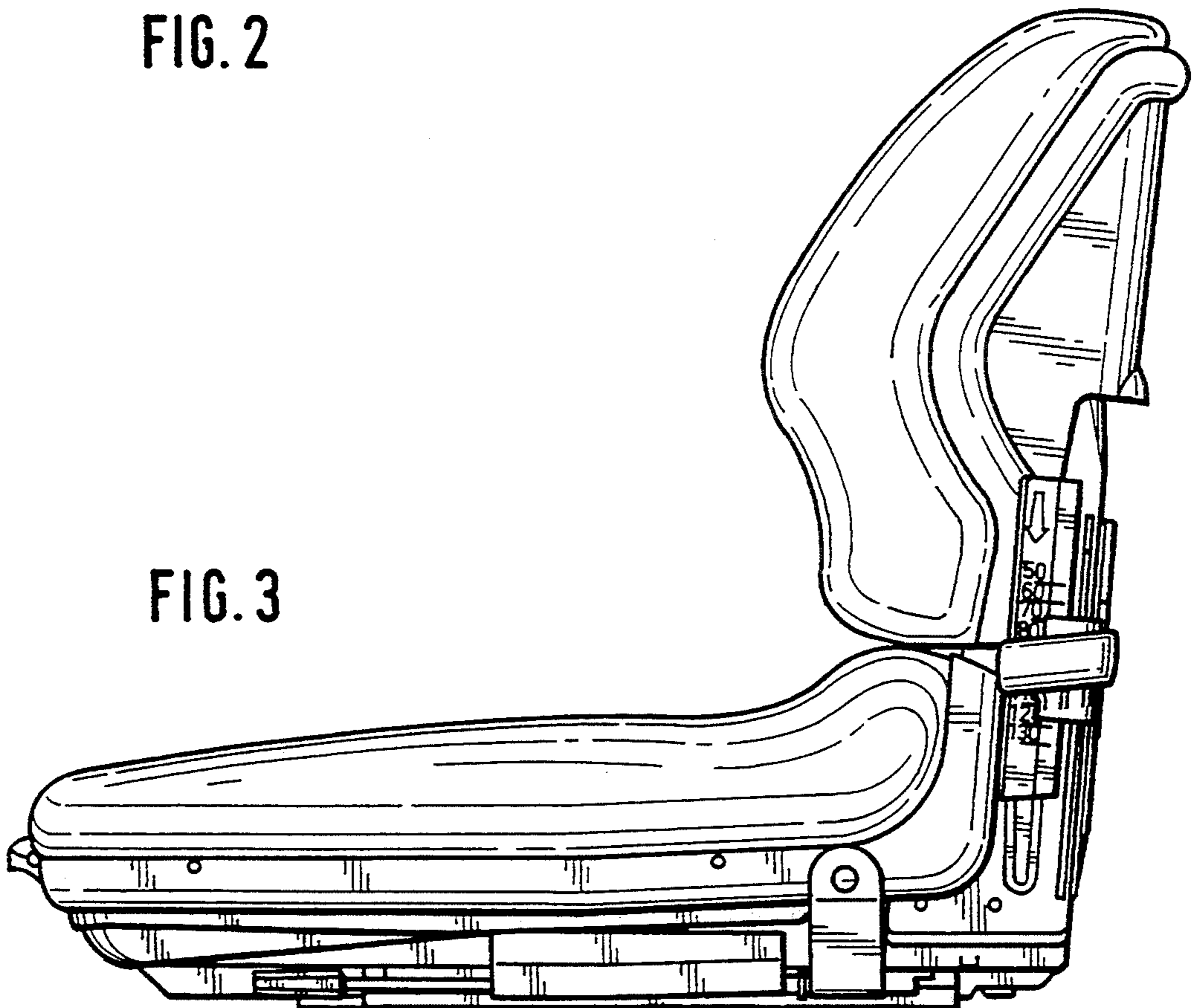

FIG. 3

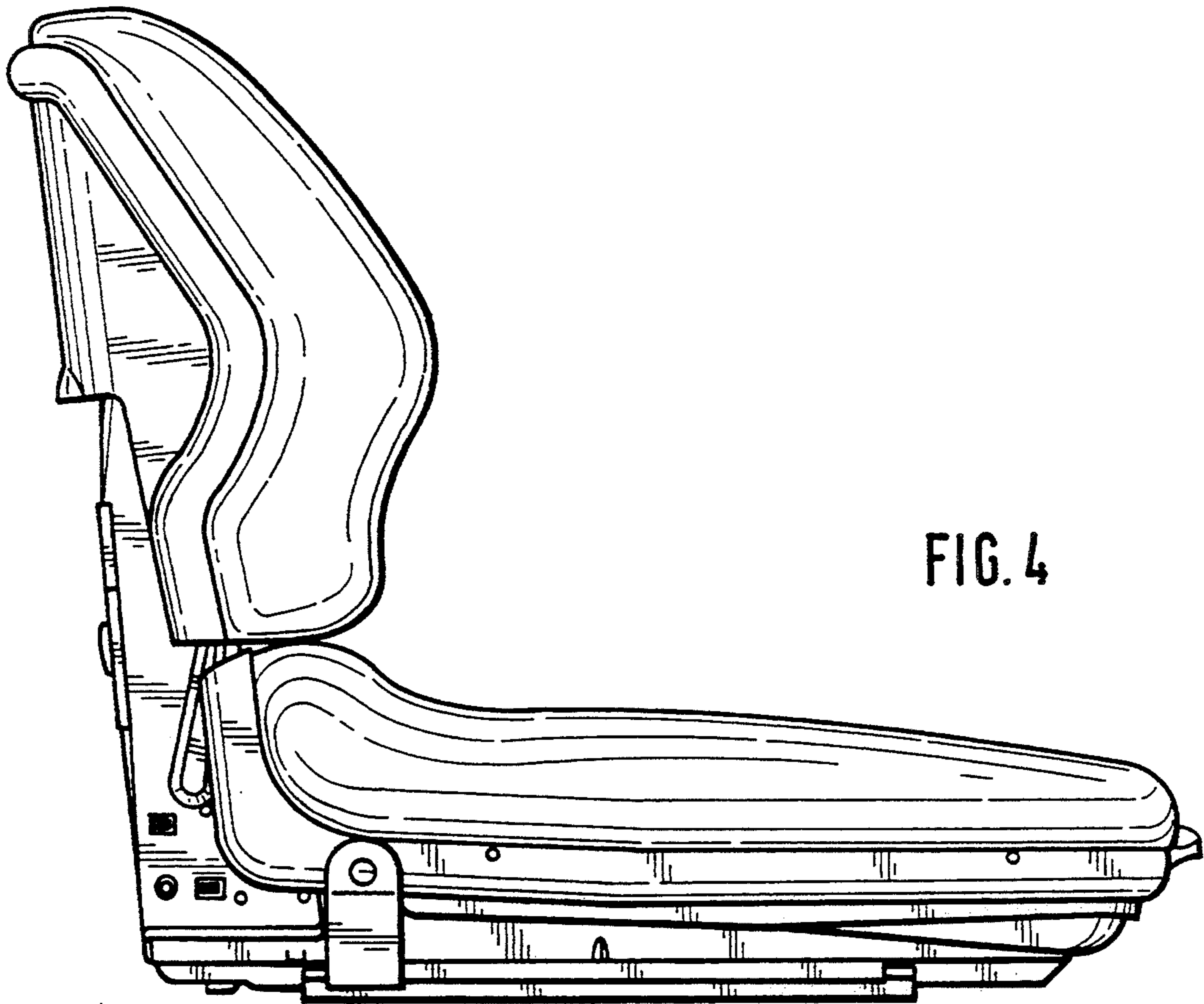
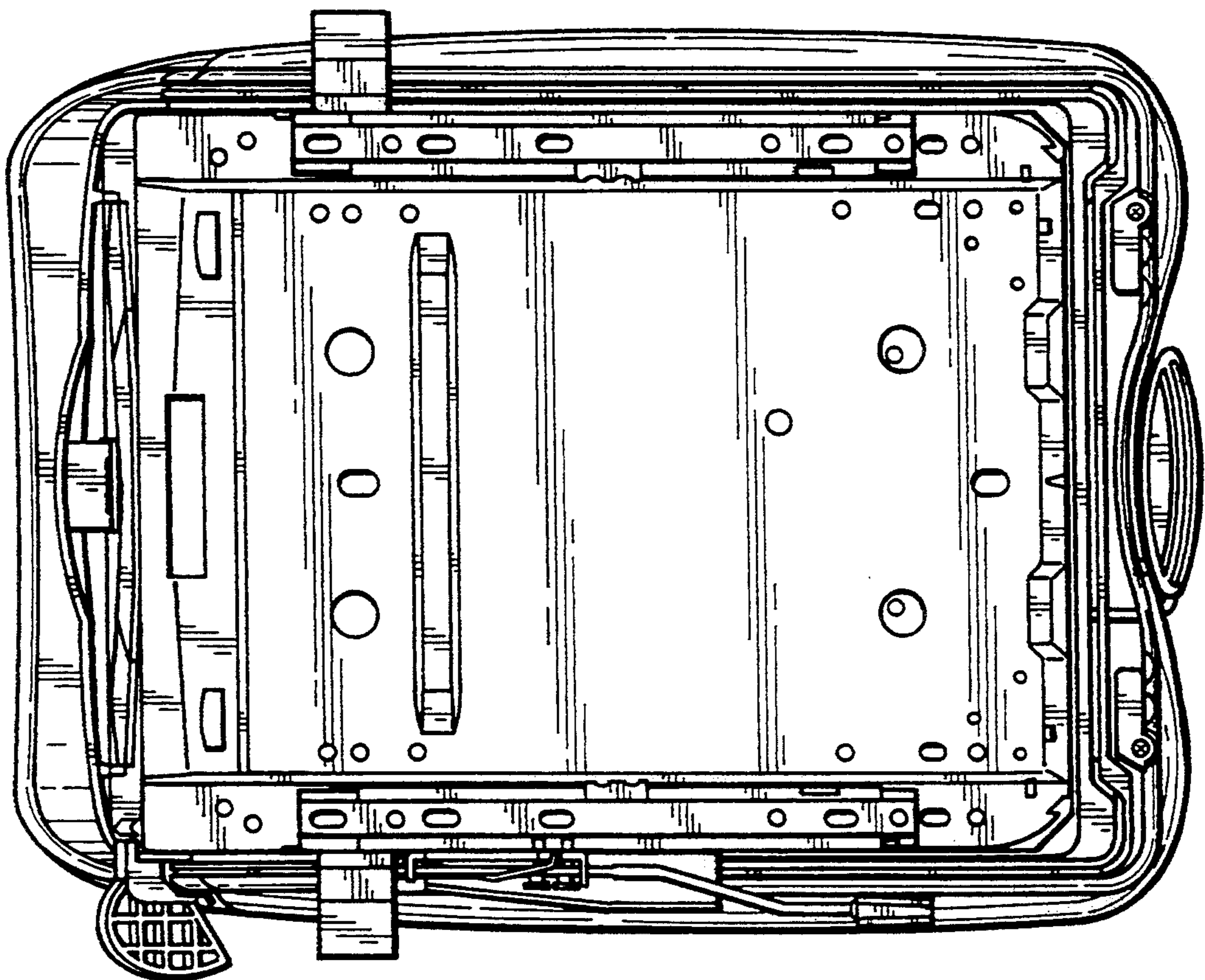

FIG. 4

FIG. 5



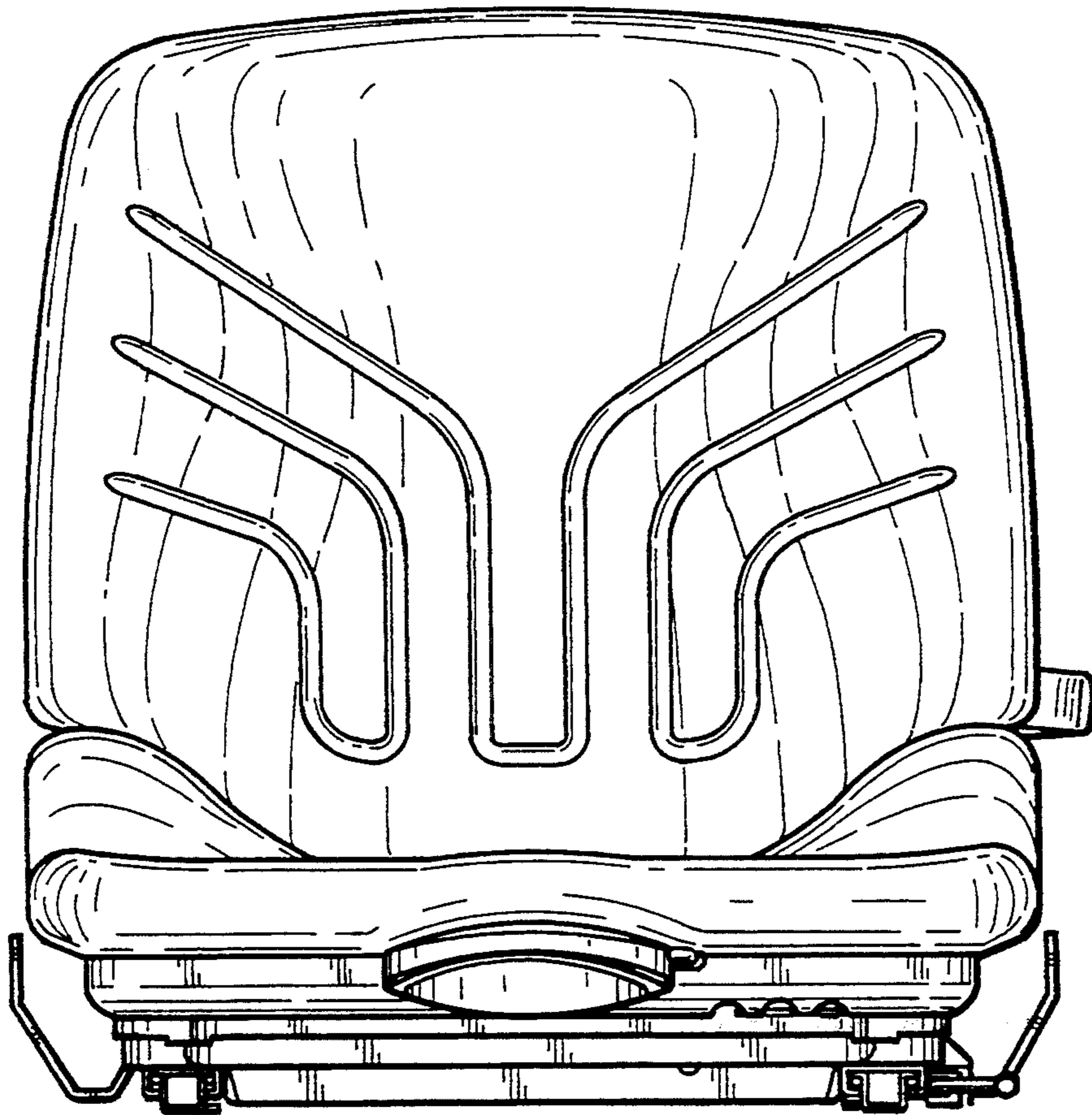

FIG. 6

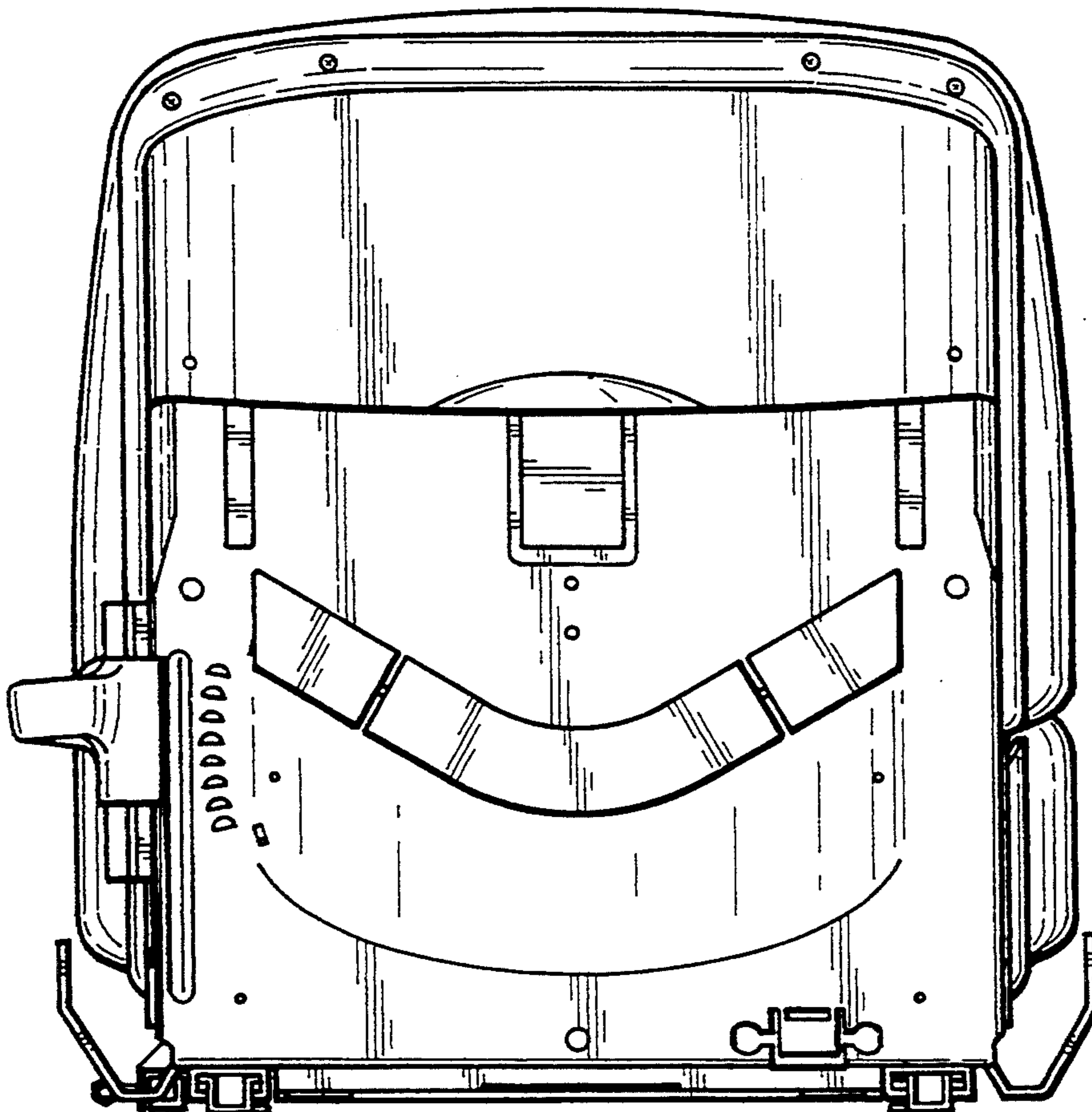

FIG. 7