



US00D361950S

United States Patent [19]

[11] Patent Number: **Des. 361,950**

Mascio

[45] Date of Patent: **** Sep. 5, 1995**

[54] TIRE AIR PRESSURE EQUALIZER

5,158,122 10/1992 Moffett 141/38

[76] Inventor: **John R. Mascio**, 6794 Hamilton Dr.,
Derby, N.Y. 14047

Primary Examiner—Antoine Duval Davis
Attorney, Agent, or Firm—Terry M. Gernstein

[**] Term: **14 Years**

[57] **CLAIM**

[21] Appl. No.: **21,869**

The ornamental design for a tire air pressure equalizer,
as shown an described.

[22] Filed: **Apr. 25, 1994**

DESCRIPTION

[52] U.S. Cl. **D10/86**

[58] Field of Search **D10/86, 87;**
73/146.2-146.8; 116/34 R; 137/227, 231;
141/38, 83, 93, 242, 383; 152/415-417

FIG. 1 is a front, top and side perspective view of the
tire air pressure equalizer showing my new design, the
air conduits being broken away to show indeterminate
length;

FIG. 2 is a front elevational view thereof;

FIG. 3 is a rear elevational view thereof;

FIG. 4 is a side elevational view thereof, the side oppo-
site being a mirror image of the side shown in FIG. 4;

FIG. 5 is a top plan view thereof;

FIG. 6 is a bottom plan view thereof; and,

FIG. 7 is a perspective view thereof.

[56] **References Cited**

U.S. PATENT DOCUMENTS

D. 259,863	7/1981	Eller	D10/86
4,658,869	4/1987	Soon-Fu	141/98
4,844,138	7/1989	Kokubu	141/38
5,012,954	5/1991	Will	141/38

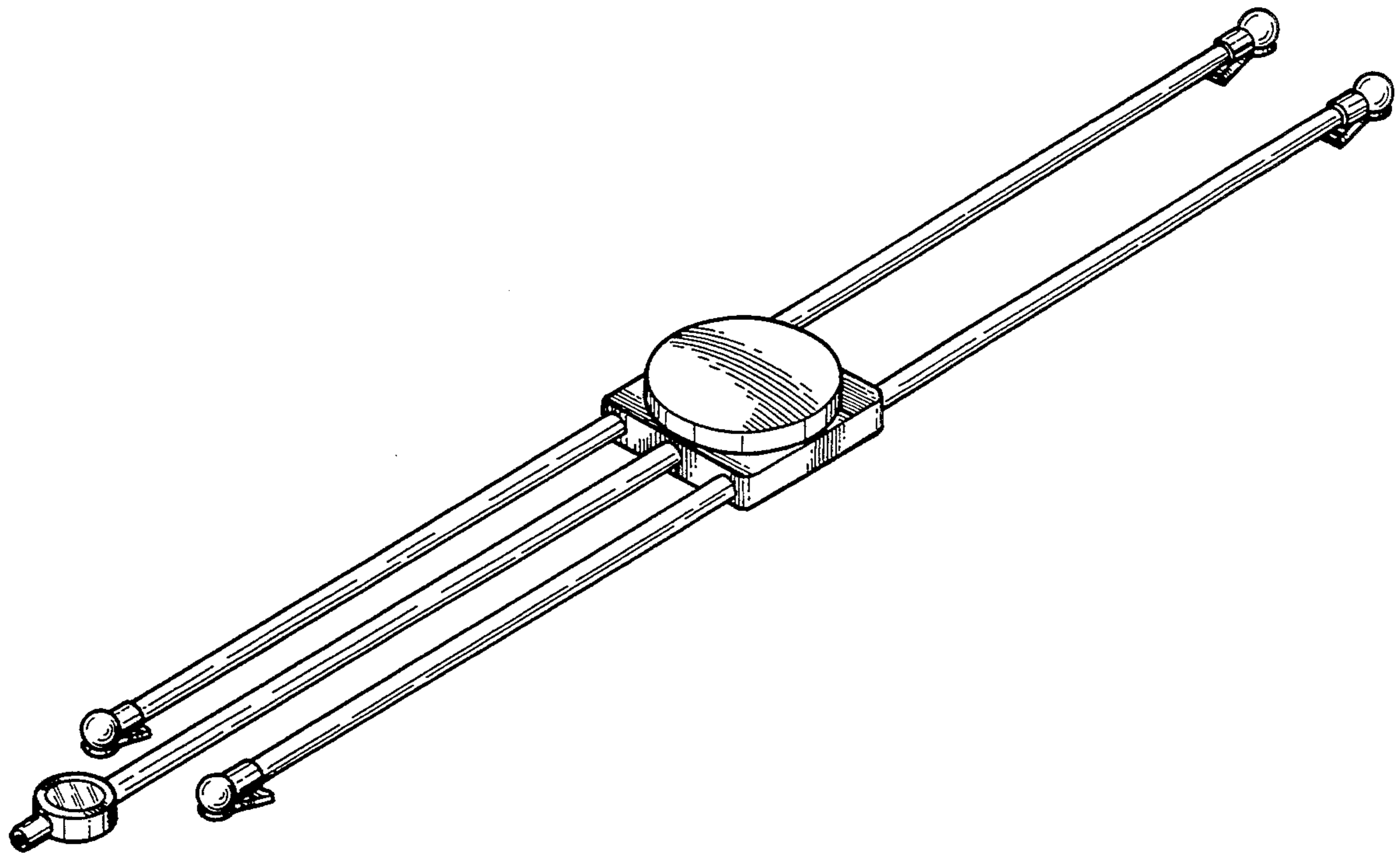

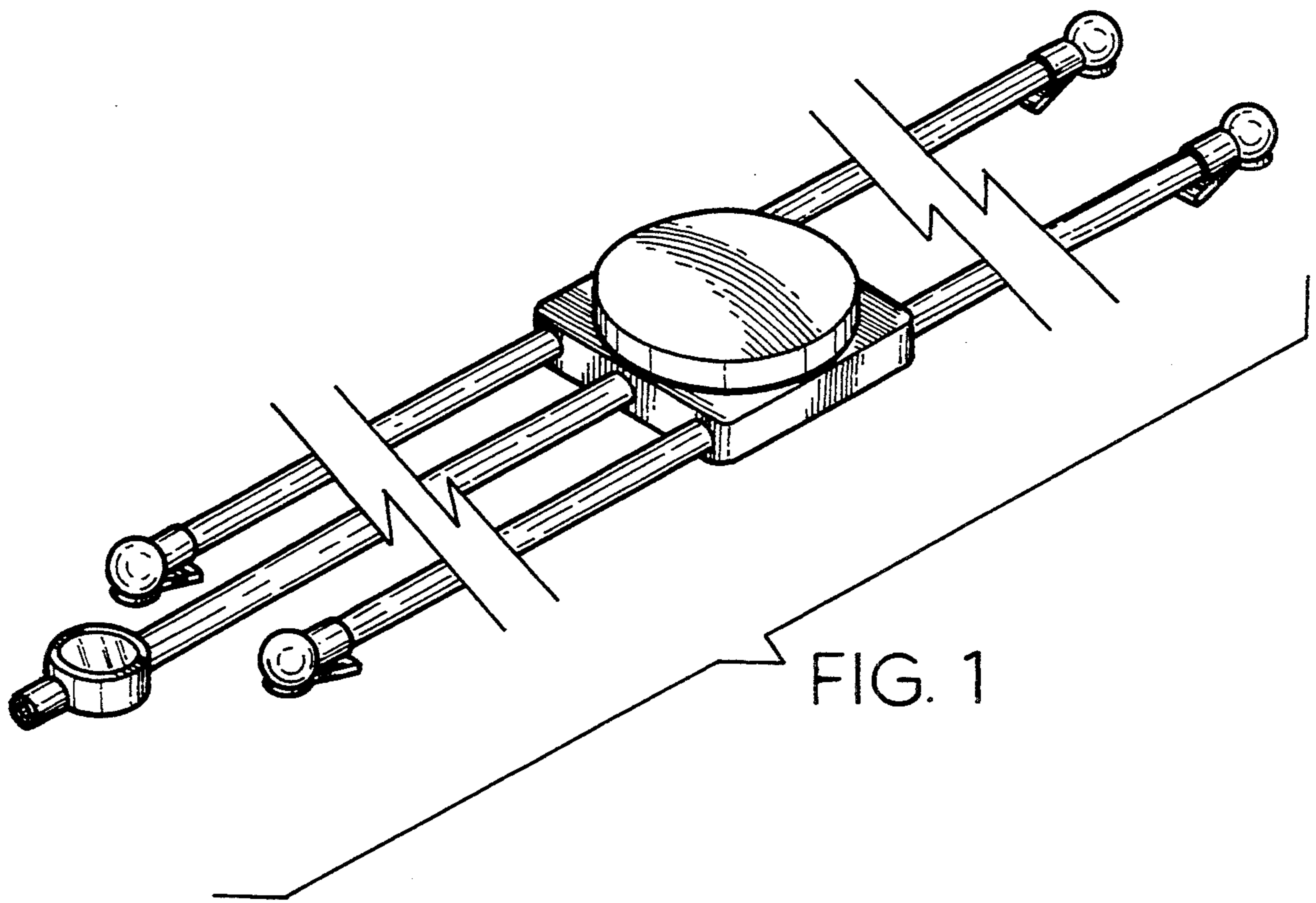

FIG. 1



FIG. 2

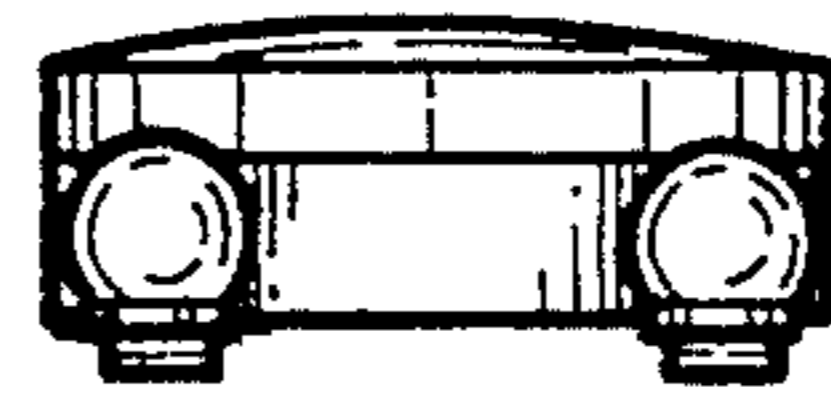

FIG. 3

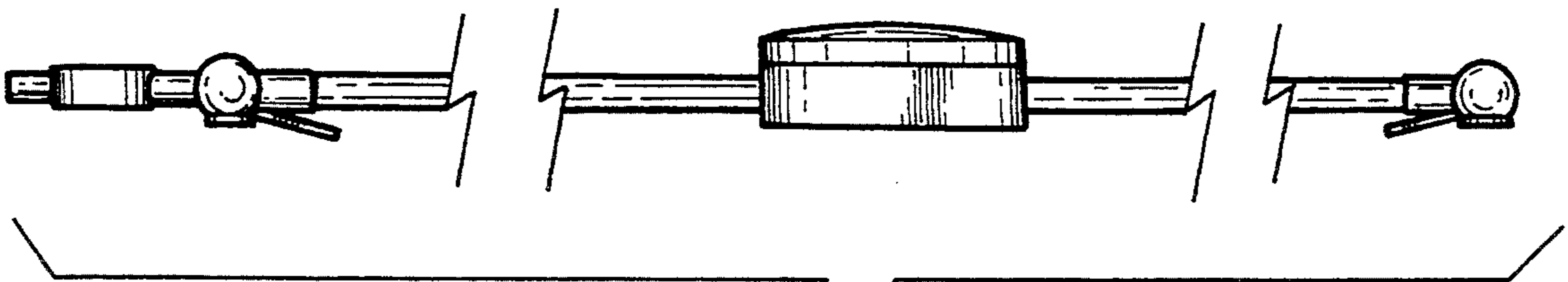

FIG. 4

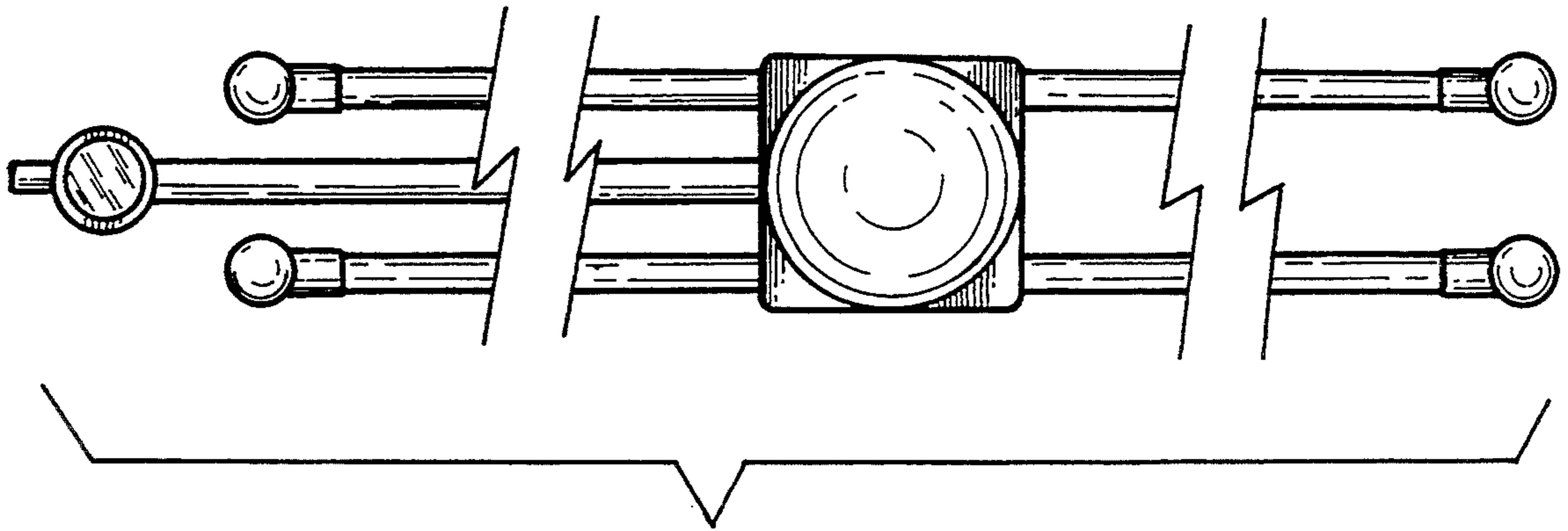

FIG. 5

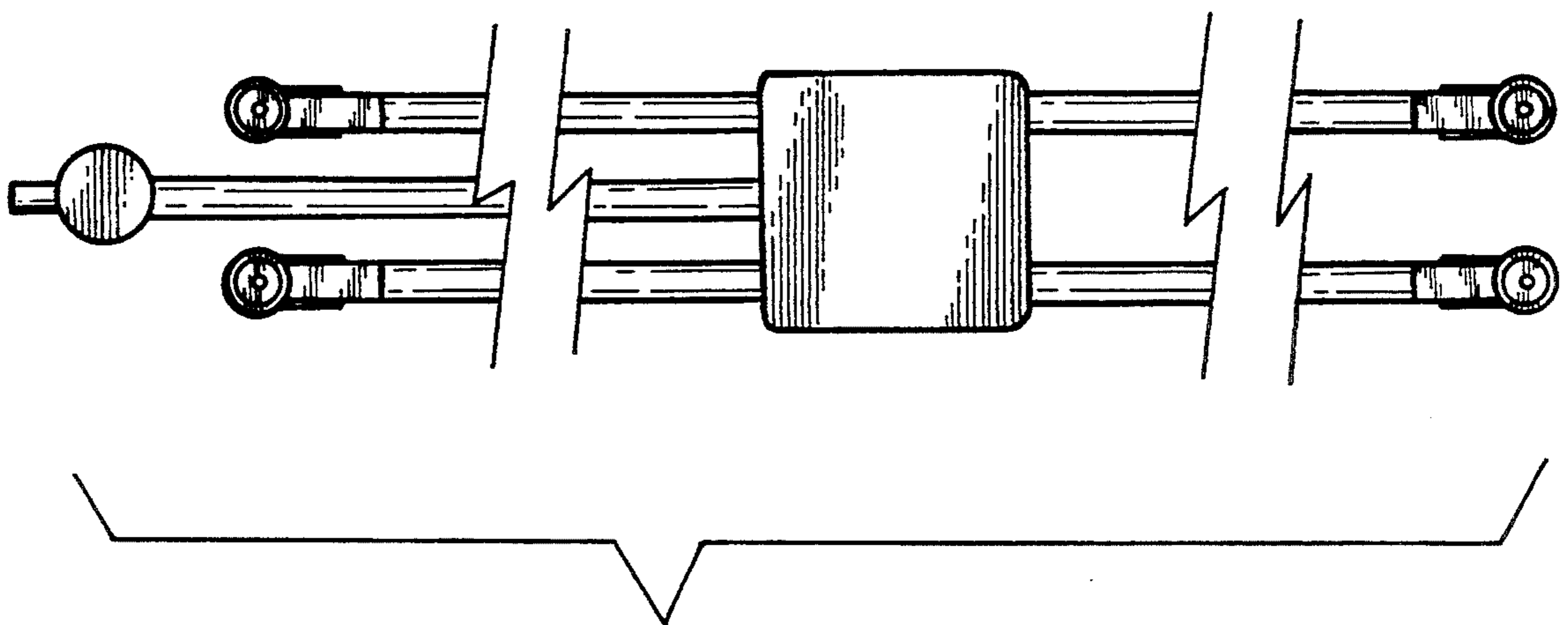

FIG. 6

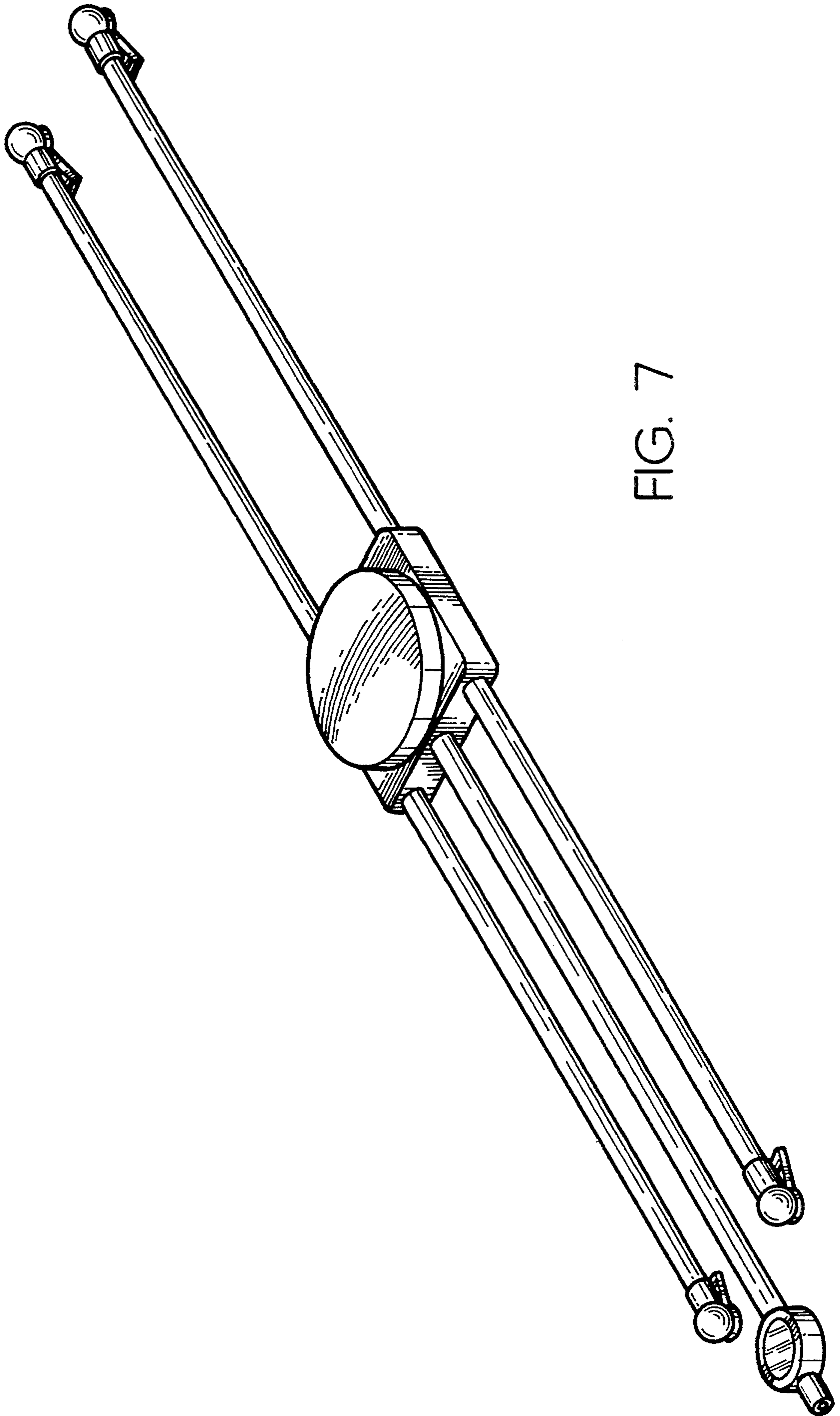

FIG. 7