



US00D361891S

United States Patent [19]

[11] Patent Number: **Des. 361,891**

Kuwahara et al.

[45] Date of Patent: **** Sep. 5, 1995**

[54] **BAG FOR A CAR COVER**

[75] Inventors: **Kiyoshi Kuwahara; Masako Kuwahara**, both of Fujiidera; **Akira Yoshida**, Tondabayashi, all of Japan

[73] Assignee: **Perfect Shoji Kabushiki Kaisha**, Osaka, Japan

[**] Term: **14 Years**

[21] Appl. No.: **12,058**

[22] Filed: **Aug. 23, 1993**

[52] U.S. Cl. **D3/303**

[58] Field of Search **D3/201, 226, 230, 231, D3/232, 233, 242, 243, 303; 190/100, 103, 104, 106, 113, 118, 130, 129, 105; 150/154, 157, 166, 108, 113; 383/97, 111; 296/136**

[56] **References Cited**

U.S. PATENT DOCUMENTS

D. 224,072	6/1972	Rosenblum	150/113 X
3,347,299	10/1967	Alexander	150/113
3,563,594	2/1977	London	150/166 X
4,856,842	8/1989	Ross et al.	150/166 X
5,009,319	4/1991	Jantzen	206/544
5,078,330	1/1992	Hall	150/166 X
5,188,417	2/1993	Curchod	150/166 X

Primary Examiner—Theodore M. Shooman
Assistant Examiner—Paula Mortimer
Attorney, Agent, or Firm—Wenderoth, Lind & Ponack

[57] **CLAIM**

The ornamental design for a bag for a car cover, as shown and described.

DESCRIPTION

FIG. 1 is a front elevational view of a bag for a car cover showing my new design;
 FIG. 2 is a rear elevational view thereof;
 FIG. 3 is a top plan view thereof;
 FIG. 4 is a bottom plan view thereof;
 FIG. 5 is a left side elevational view thereof;
 FIG. 6 is a right side elevational view thereof;
 FIG. 7 is a sectional view taken along line A—A of FIG. 1;
 FIG. 8 is a sectional view taken along line B—B of FIG. 6;
 FIG. 9 is a front perspective view thereof;
 FIG. 10 is a front perspective view in use thereof, the broken away portion of the strap is for illustrative purposes, the broken line showing of the car cover is for illustrative purposes only and forms no part of the claimed design;
 FIG. 11 is a front perspective view in use with the flap in an open position, the broken line showing of the car and cover is for illustrative purposes only and forms no part of the claimed design; and,
 FIG. 12 is an exploded front perspective view thereof. The broken line showing car and cover is for illustrative purposes only and forms no part of the claimed design.

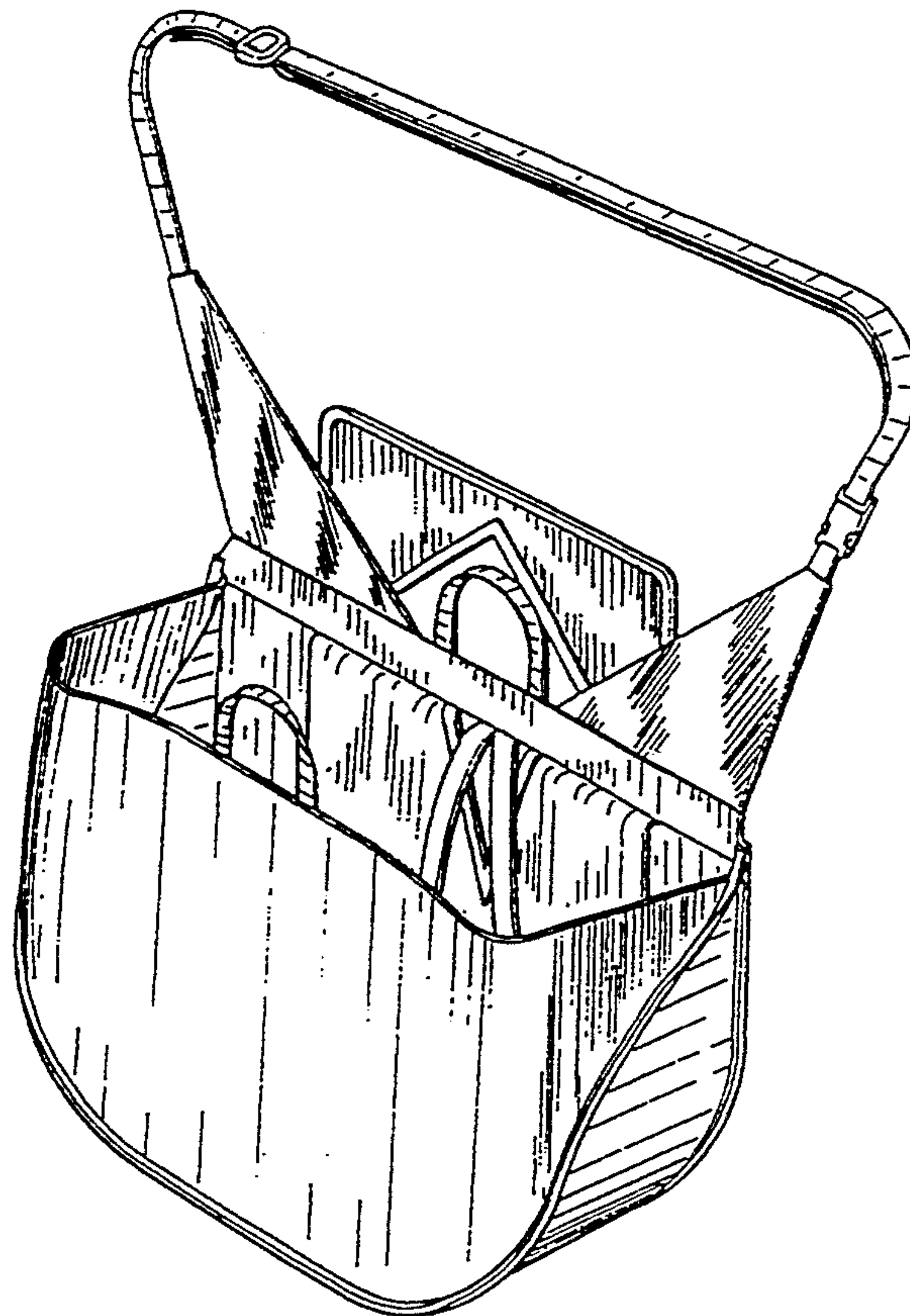

FIG. 1

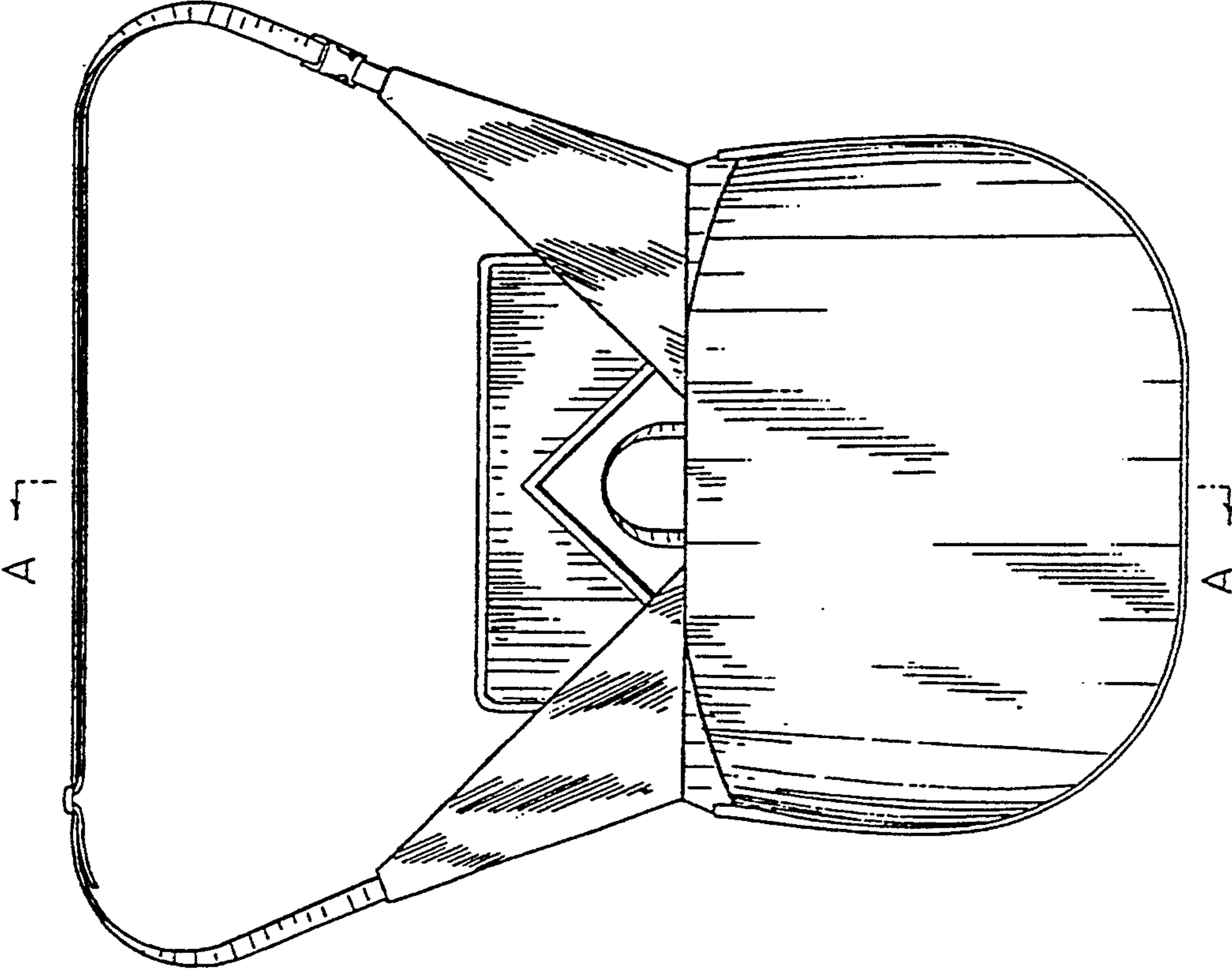

FIG. 2

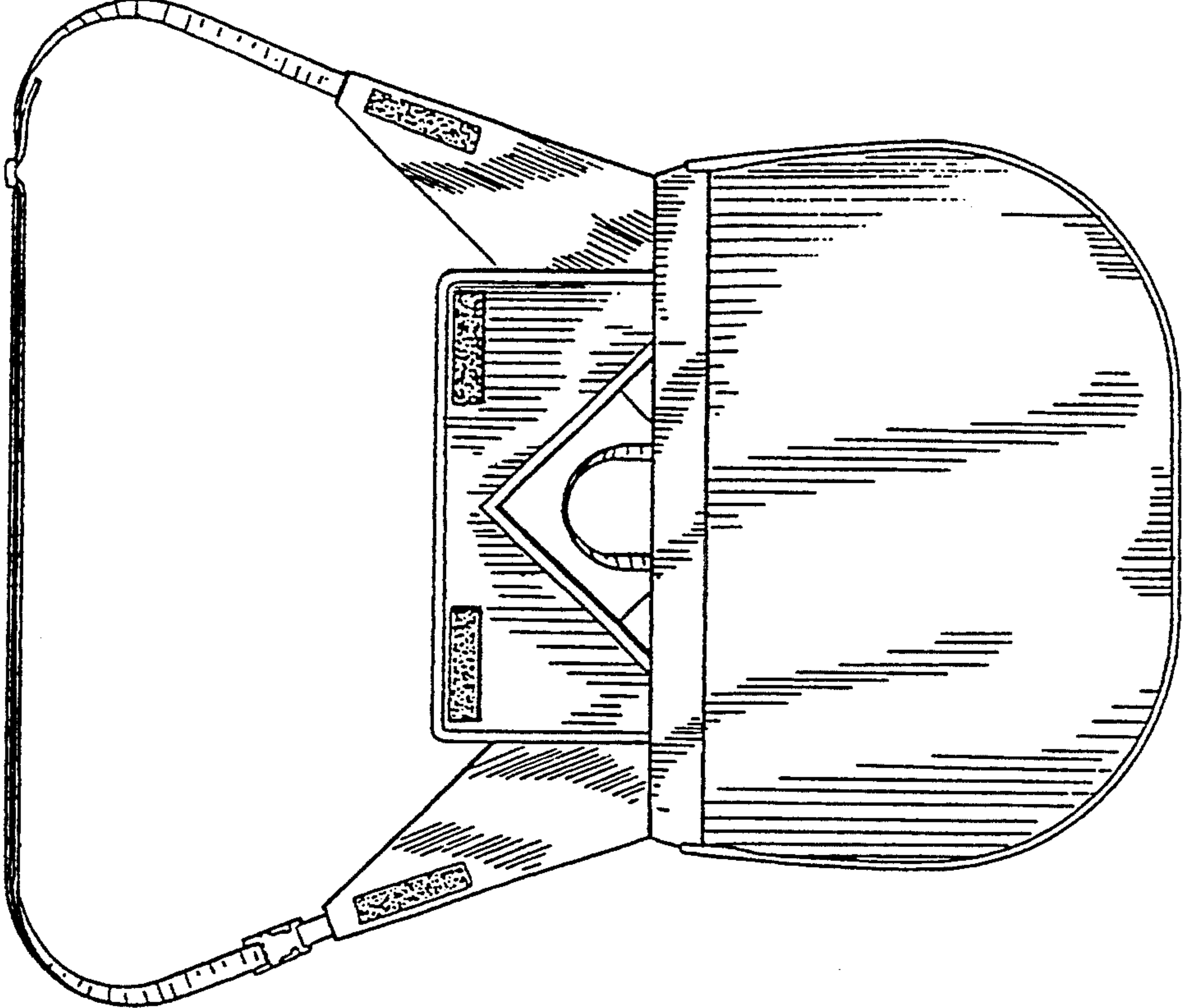

FIG. 6

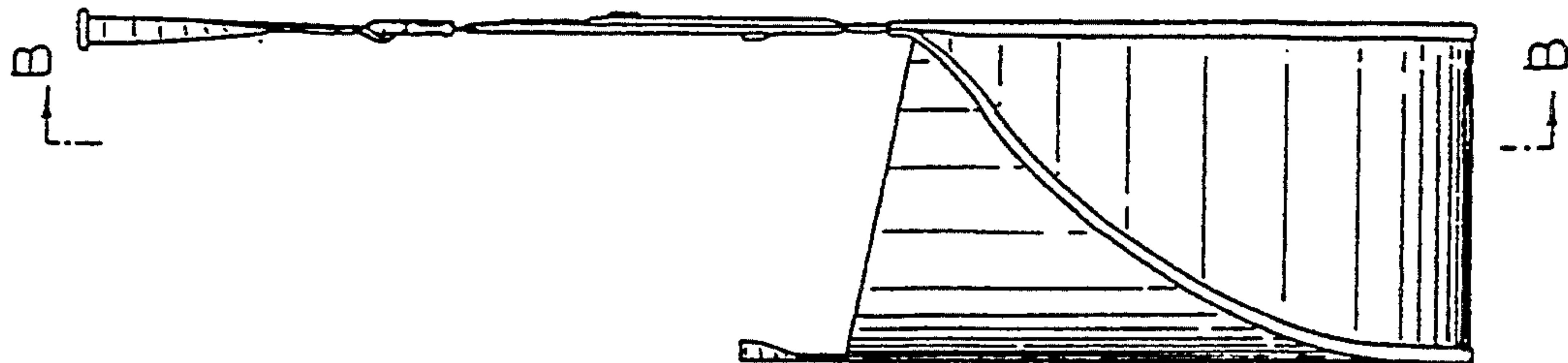

FIG. 5

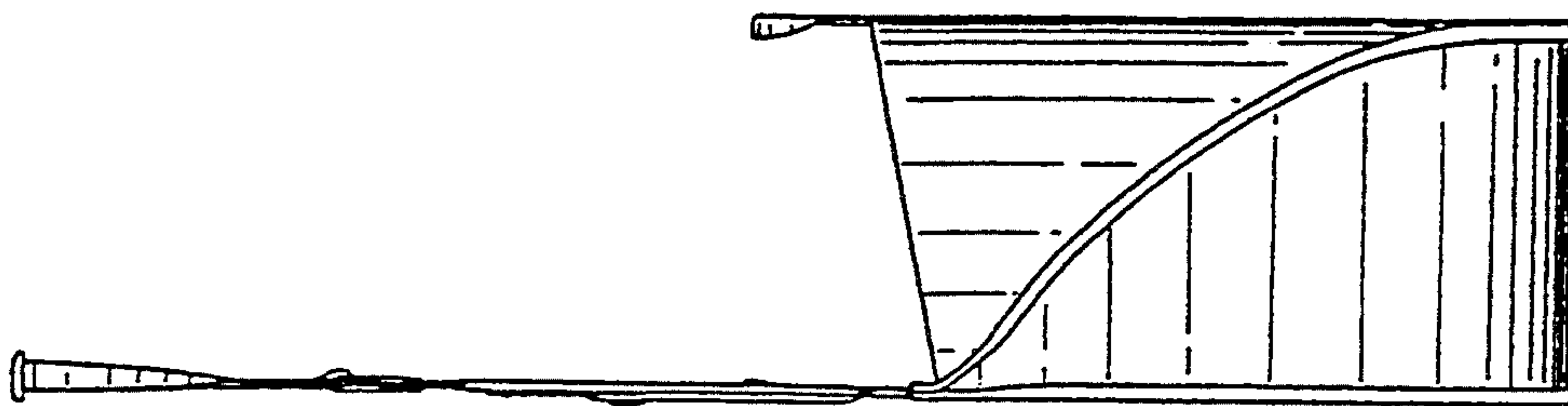

FIG. 3

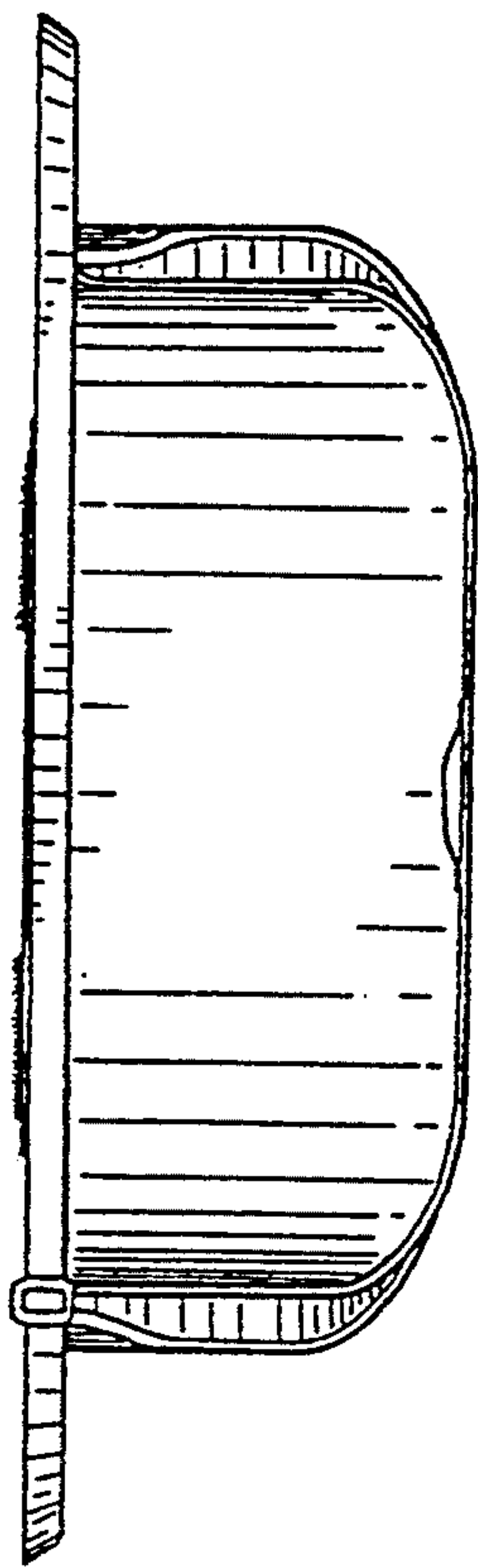

FIG. 4

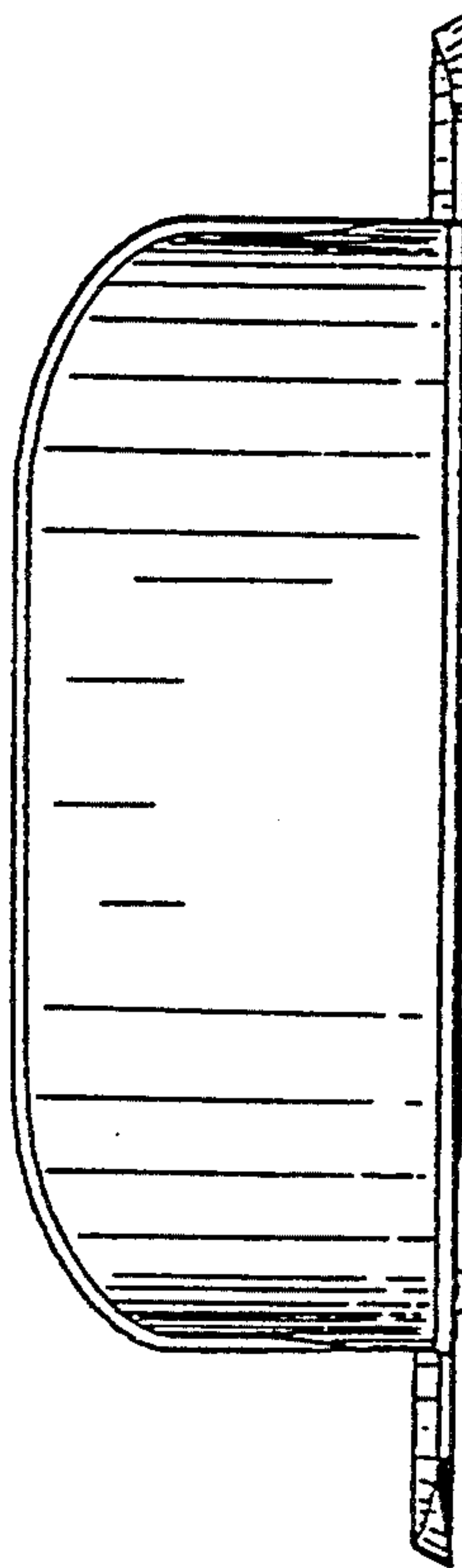

FIG. 7

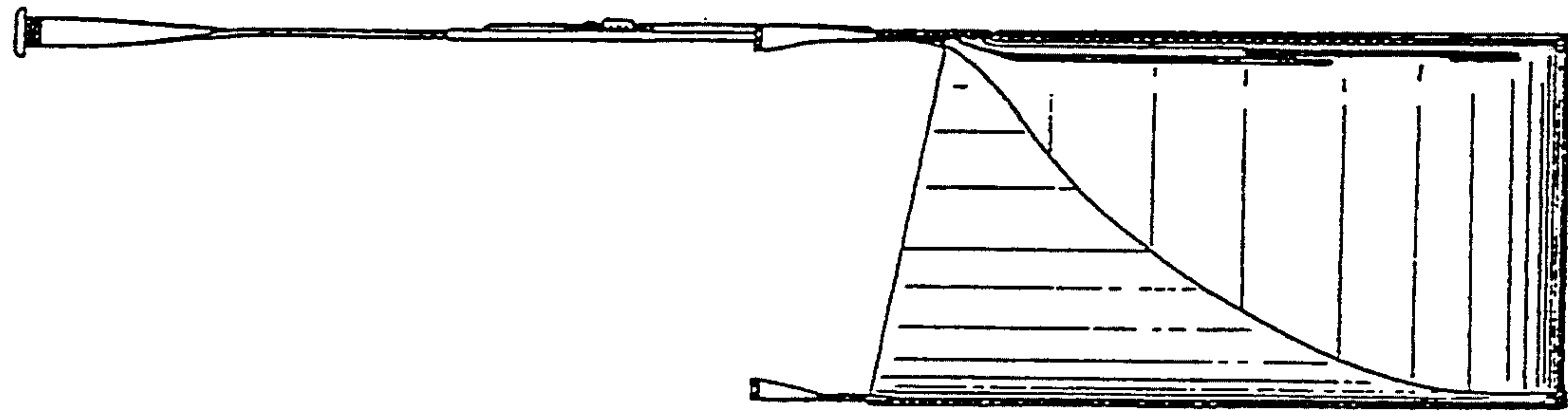

FIG. 8

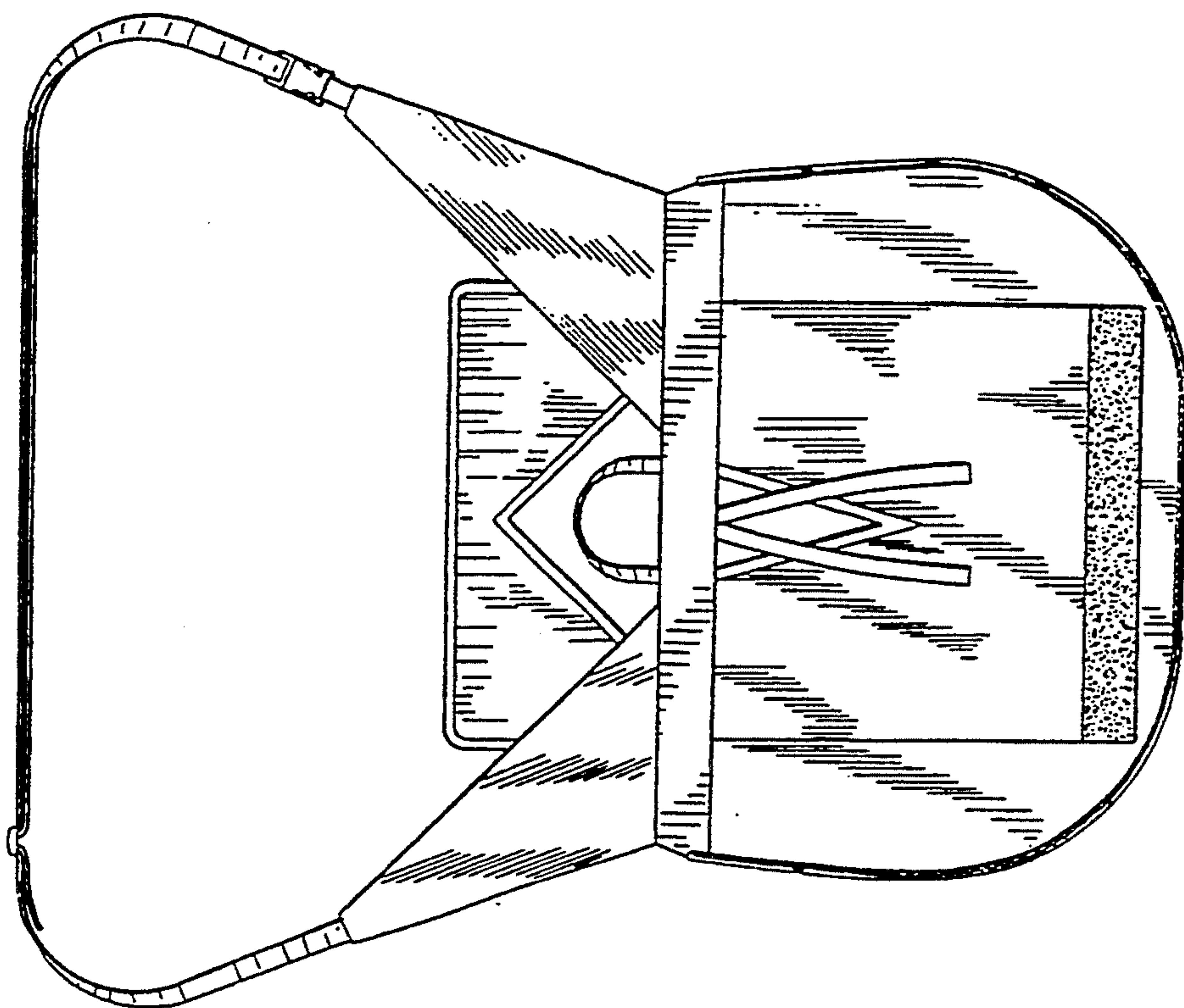

FIG. 9

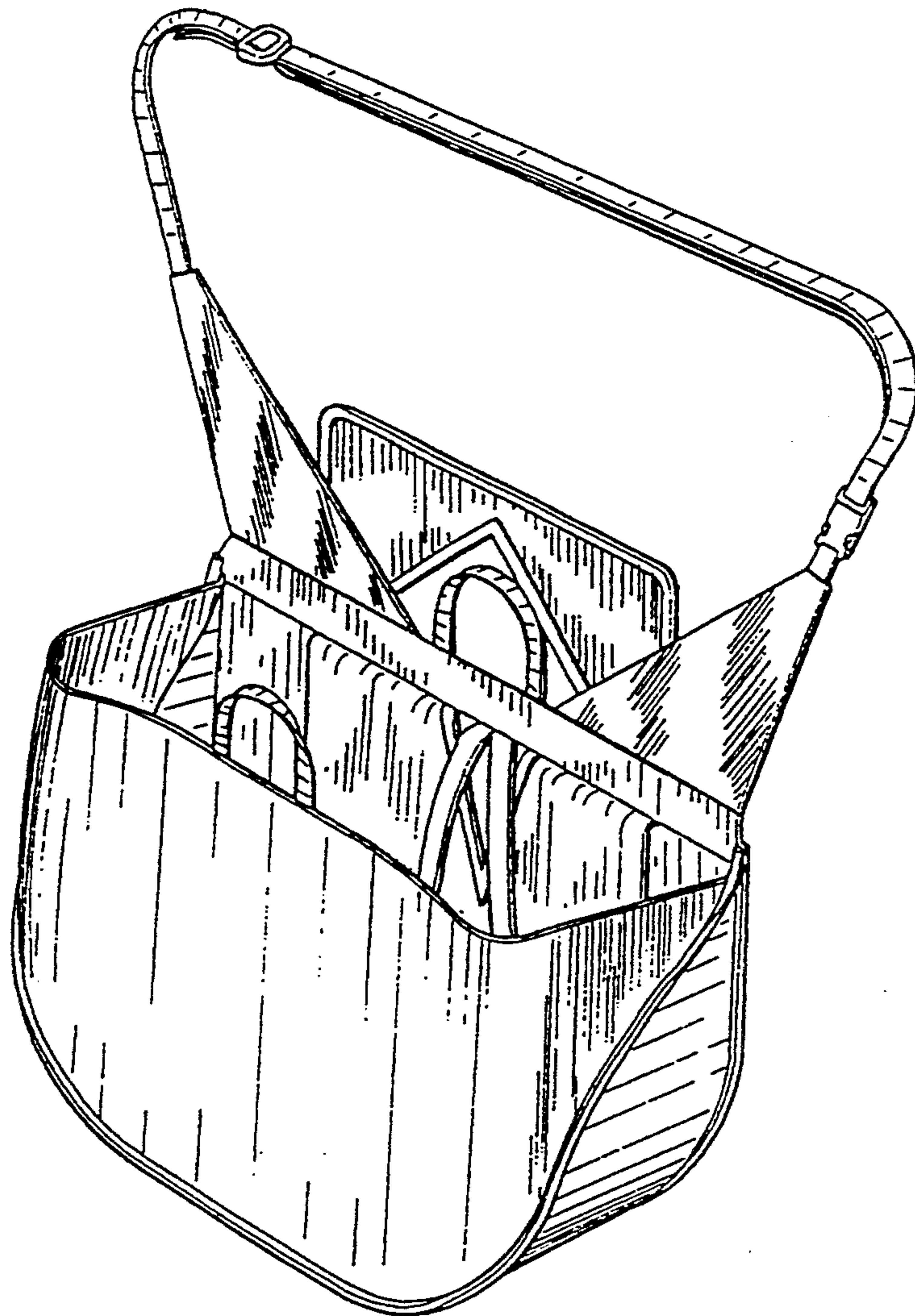

FIG. 10

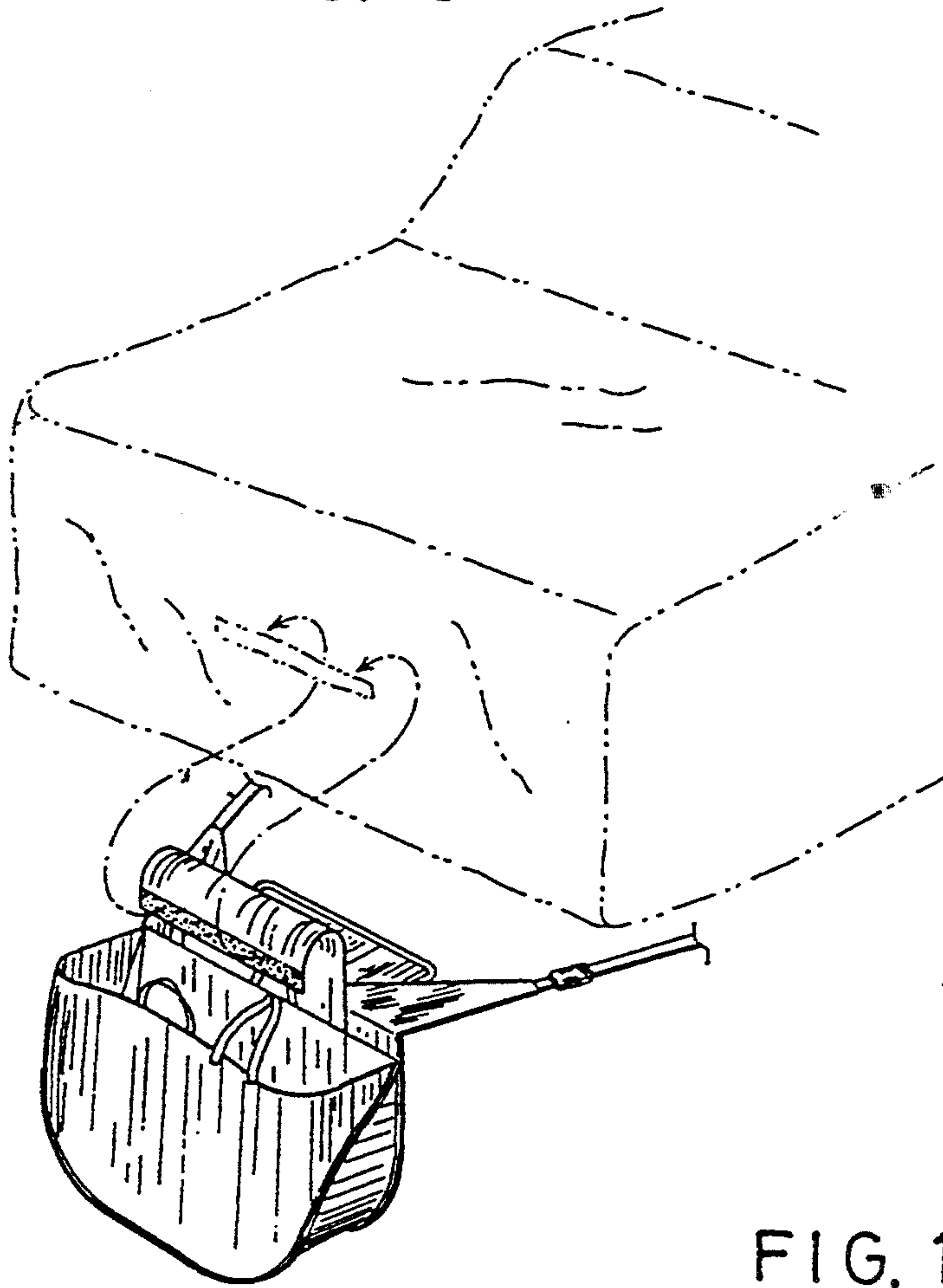

FIG. 11

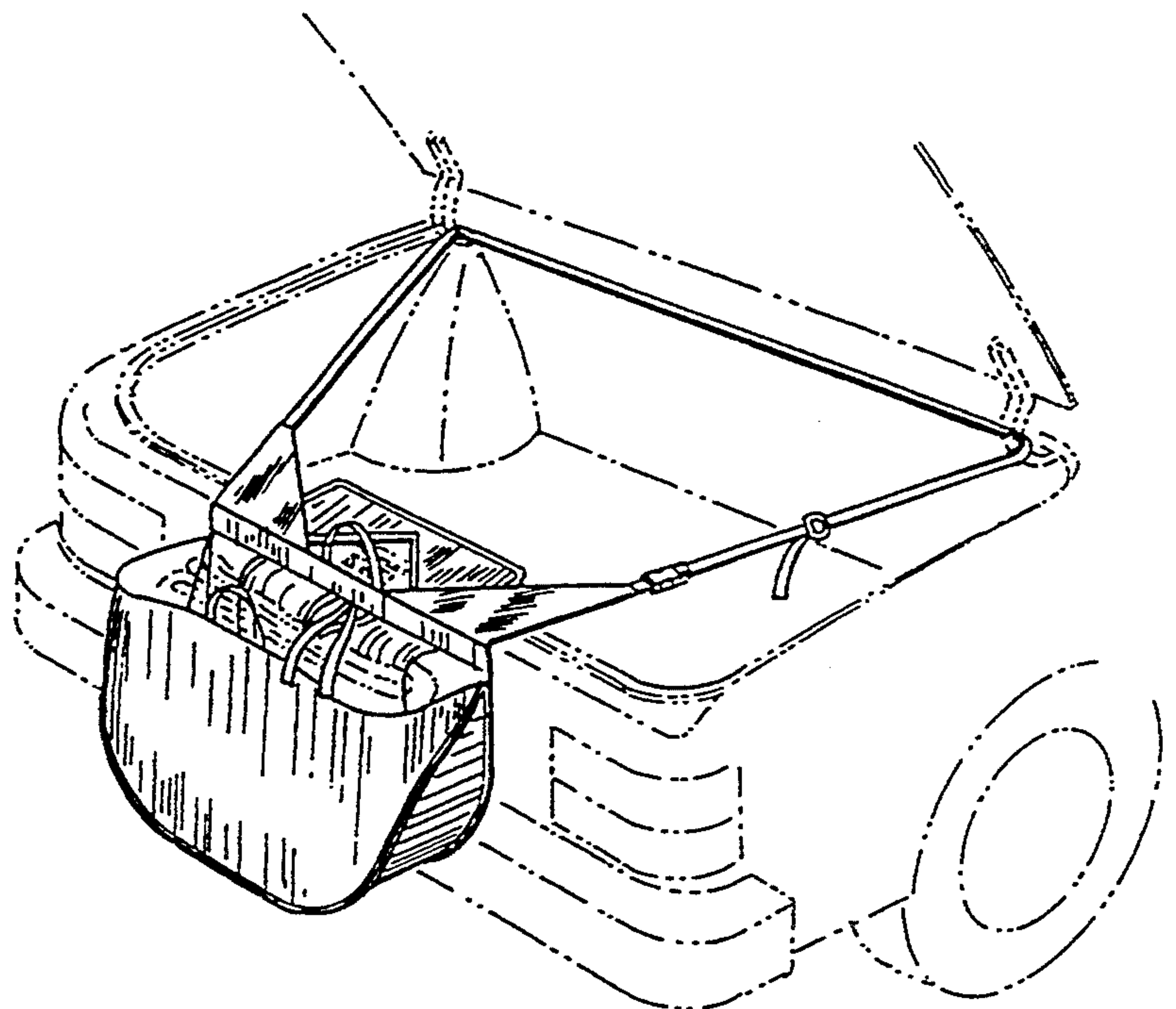

FIG. 12

