



US00D361817S

United States Patent [19] Boifava

[11] Patent Number: **Des. 361,817**

[45] Date of Patent: **** Aug. 29, 1995**

- [54] AIRPLANE AMUSEMENT RIDE
- [75] Inventor: **Mario Boifava, Vicenza, Italy**
- [73] Assignee: **Zamperla, Inc., Parsippany, N.J.**
- [**] Term: **14 Years**
- [21] Appl. No.: **20,293**
- [22] Filed: **Mar. 23, 1994**
- [52] U.S. Cl. **D21/242; D21/250**
- [58] Field of Search **D21/240, 242, 250;**
446/7, 230, 231; 472/44, 45, 47

*Assistant Examiner—*Mitchell I. Siegel
*Attorney, Agent, or Firm—*Kenyon & Kenyon

[57] **CLAIM**

The ornamental design for an airplane amusement ride, as shown and described.

DESCRIPTION

FIG. 1 is a perspective view of an airplane amusement ride showing my new design;
 FIG. 2 is a bottom perspective view thereof, the arms shown in an alternate position for clarity of illustration;
 FIG. 3 is a left side elevational view of FIG. 2;
 FIG. 4 is a right side elevational view of FIG. 2;
 FIG. 5 is a front elevational view of FIG. 2;
 FIG. 6 is a rear elevational view of FIG. 2;
 FIG. 7 is a top plan view of FIG. 2; and,
 FIG. 8 is bottom plan view of FIG. 2.
 The broken line showing of background display board is for illustrative purposes only and forms no part of the claimed design.

- [56] **References Cited**
- U.S. PATENT DOCUMENTS**
- | | | | | |
|------------|--------|---------|-------|----------|
| D. 165,593 | 1/1952 | Low | | D21/246 |
| 1,987,004 | 1/1935 | Eyerly | | 472/44 |
| 2,423,283 | 7/1947 | Austin | | 472/44 X |
| 4,842,267 | 6/1989 | Kastner | | 272/36 X |

*Primary Examiner—*Prabhakar G. Deshmukh

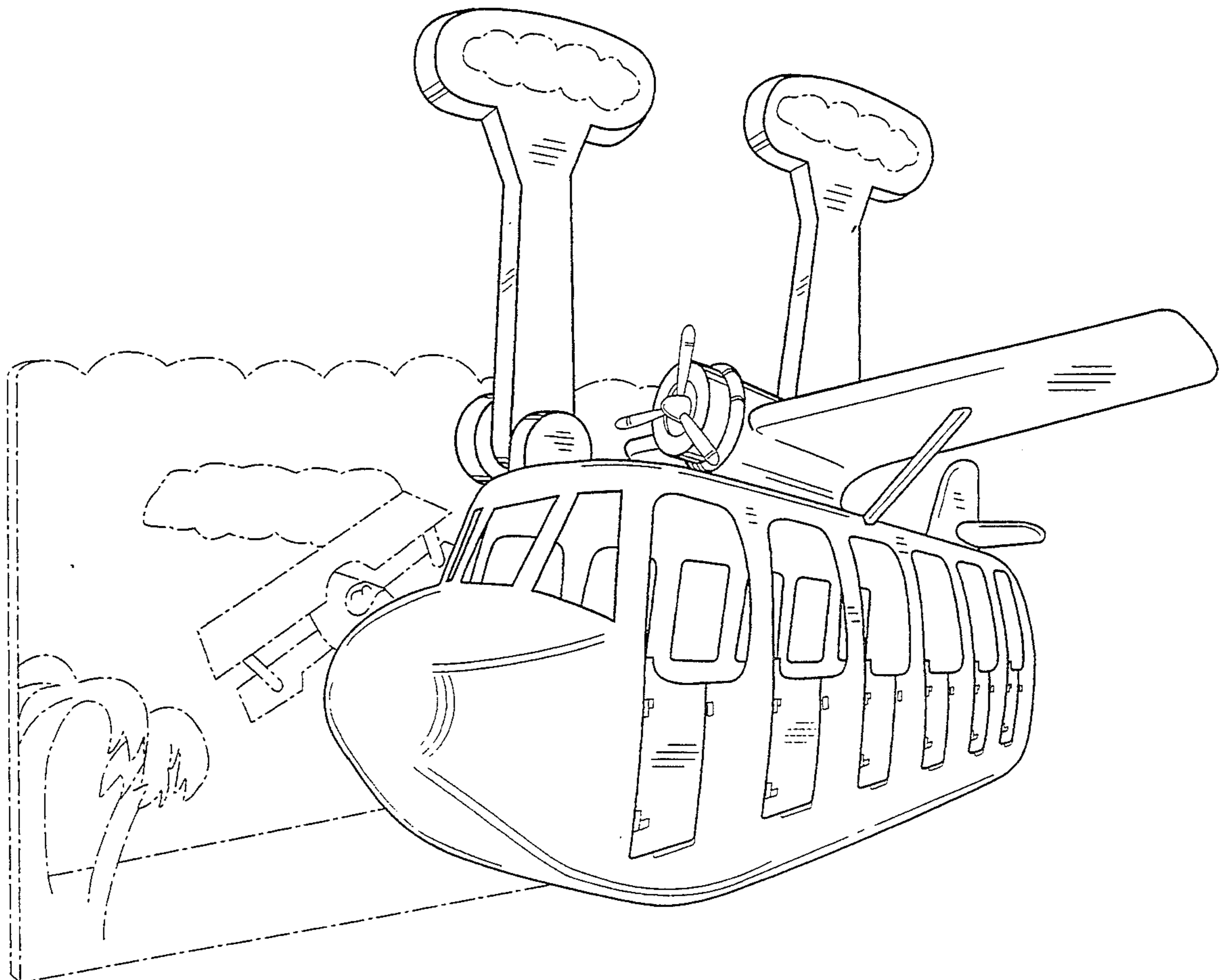

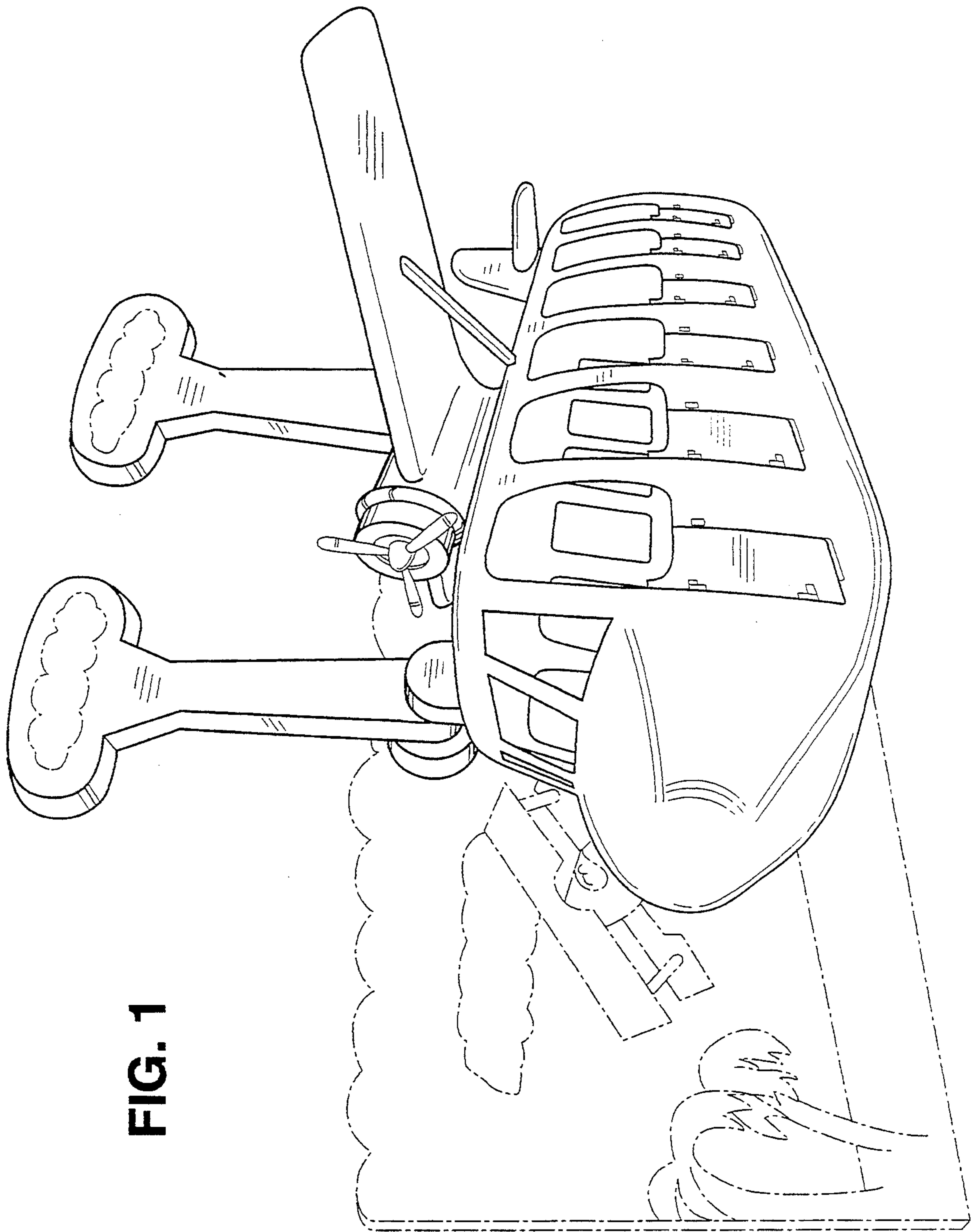

FIG. 1

FIG. 2

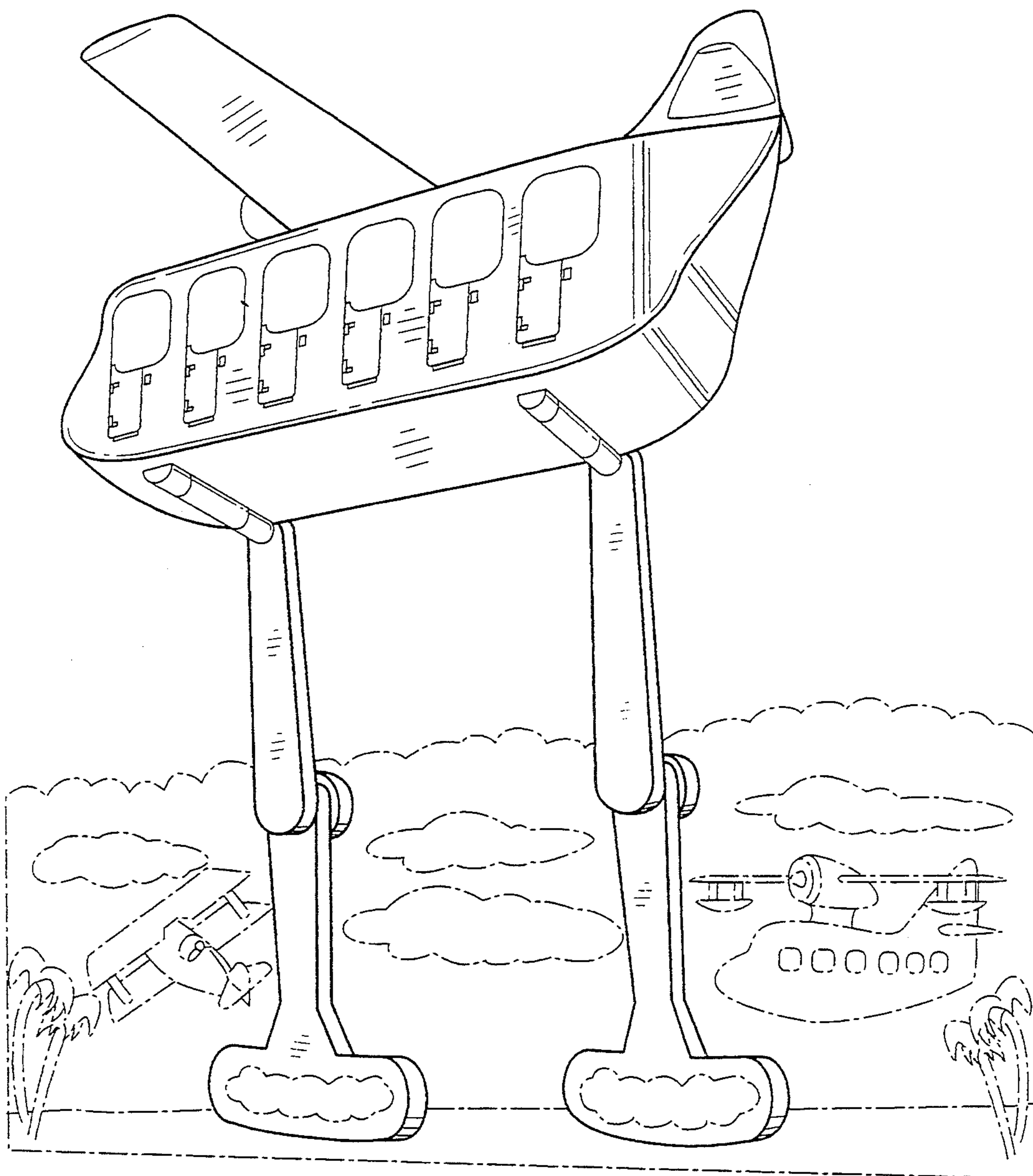

FIG. 3

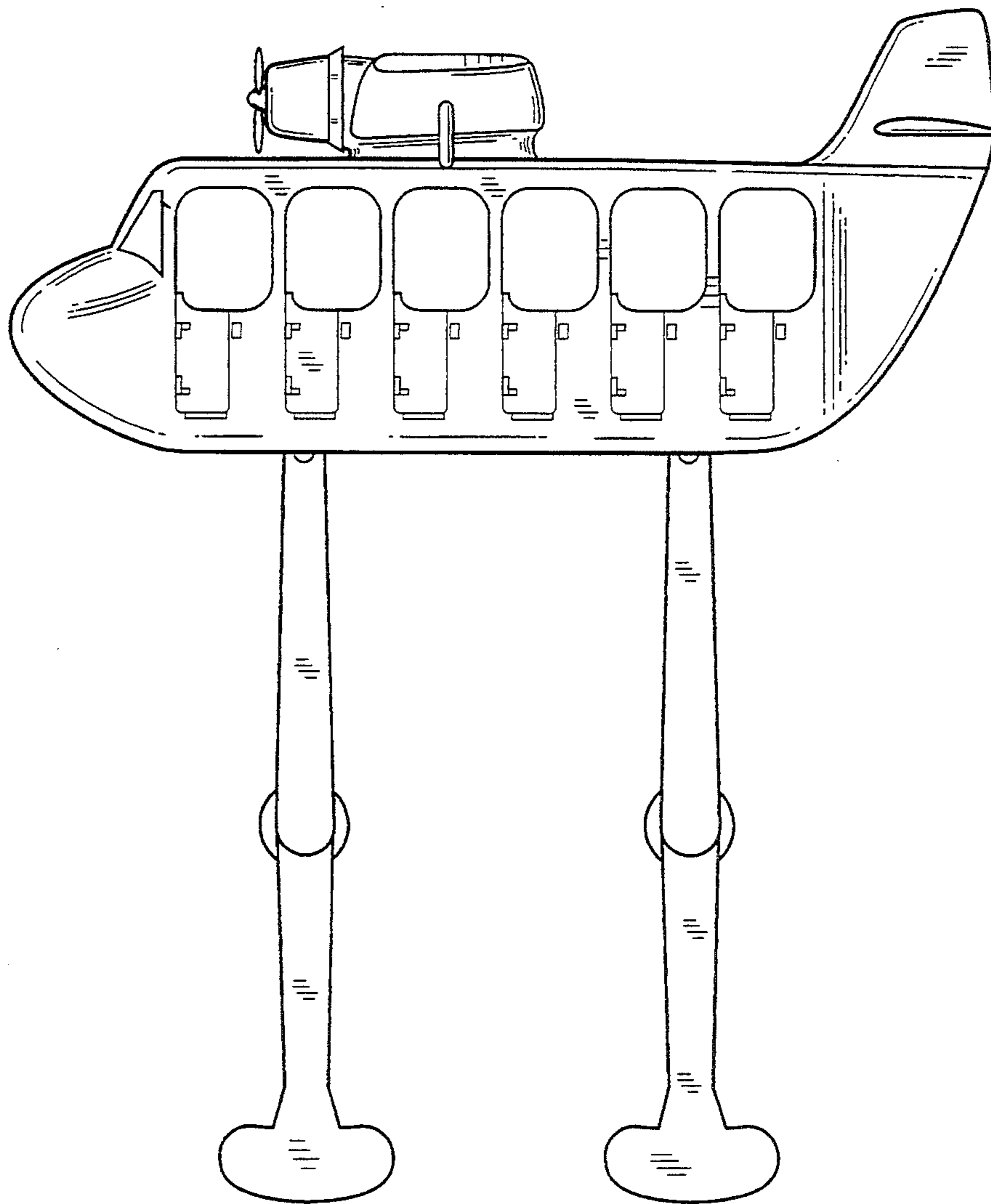
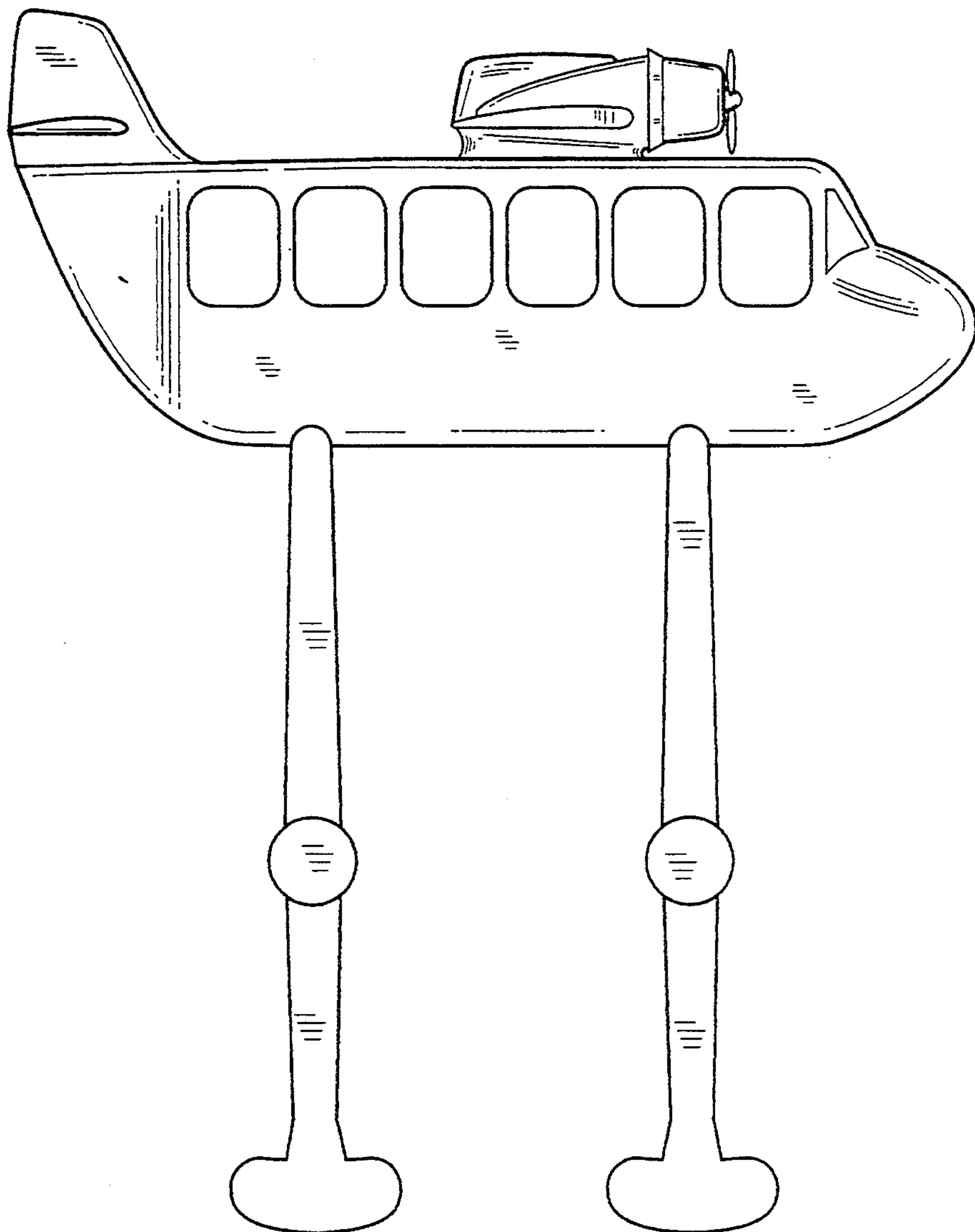

FIG. 4



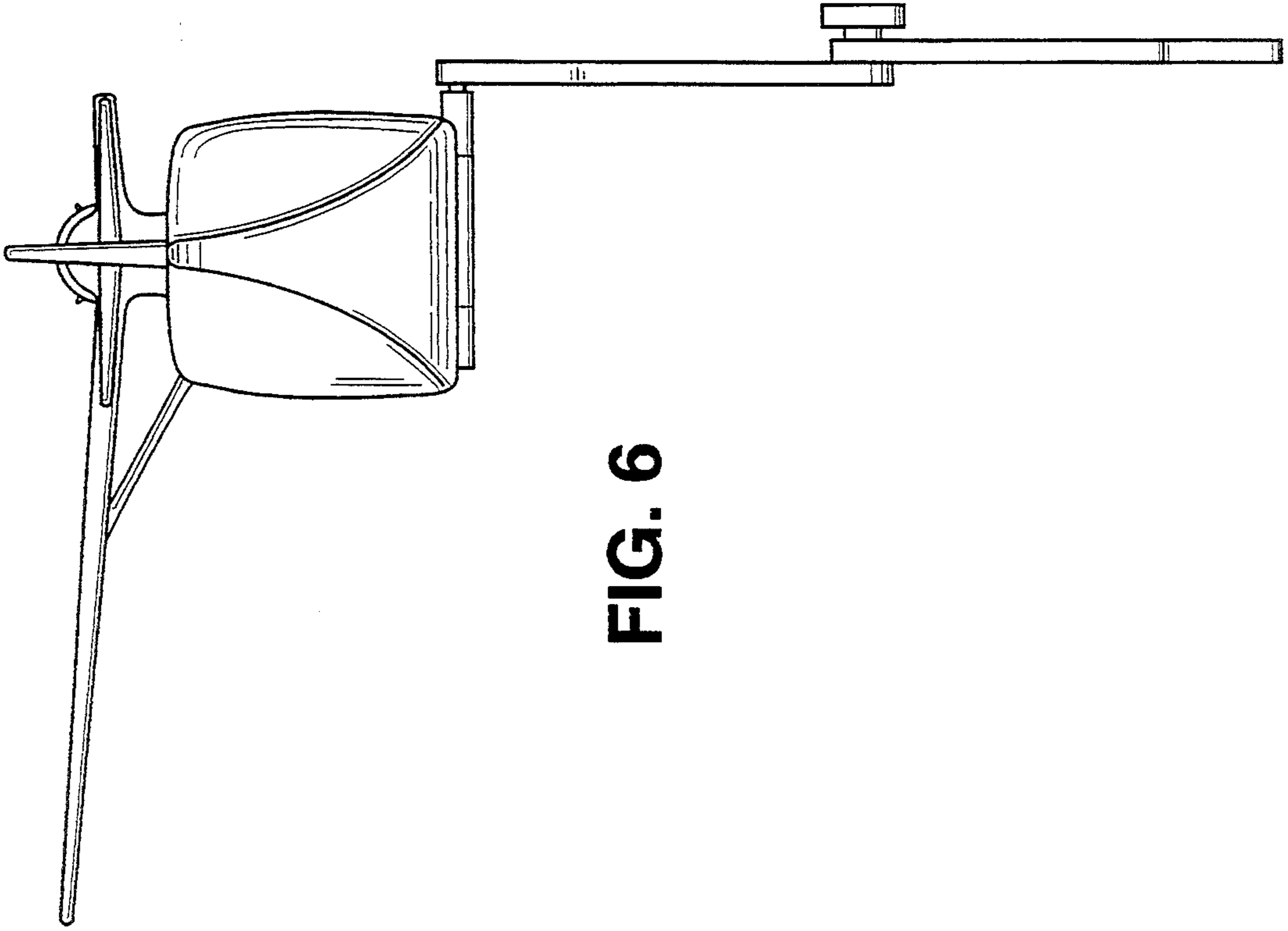

FIG. 6

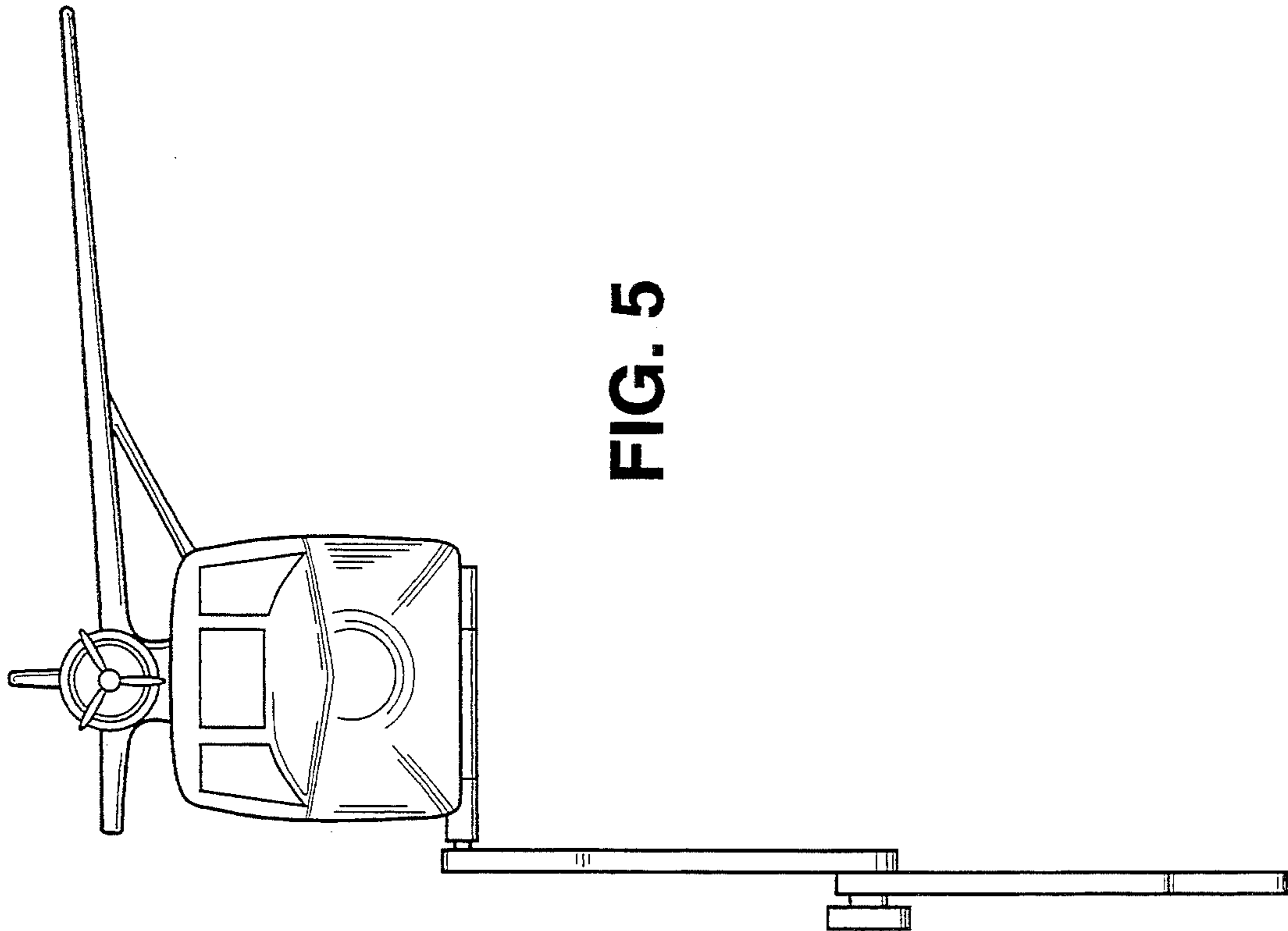

FIG. 5

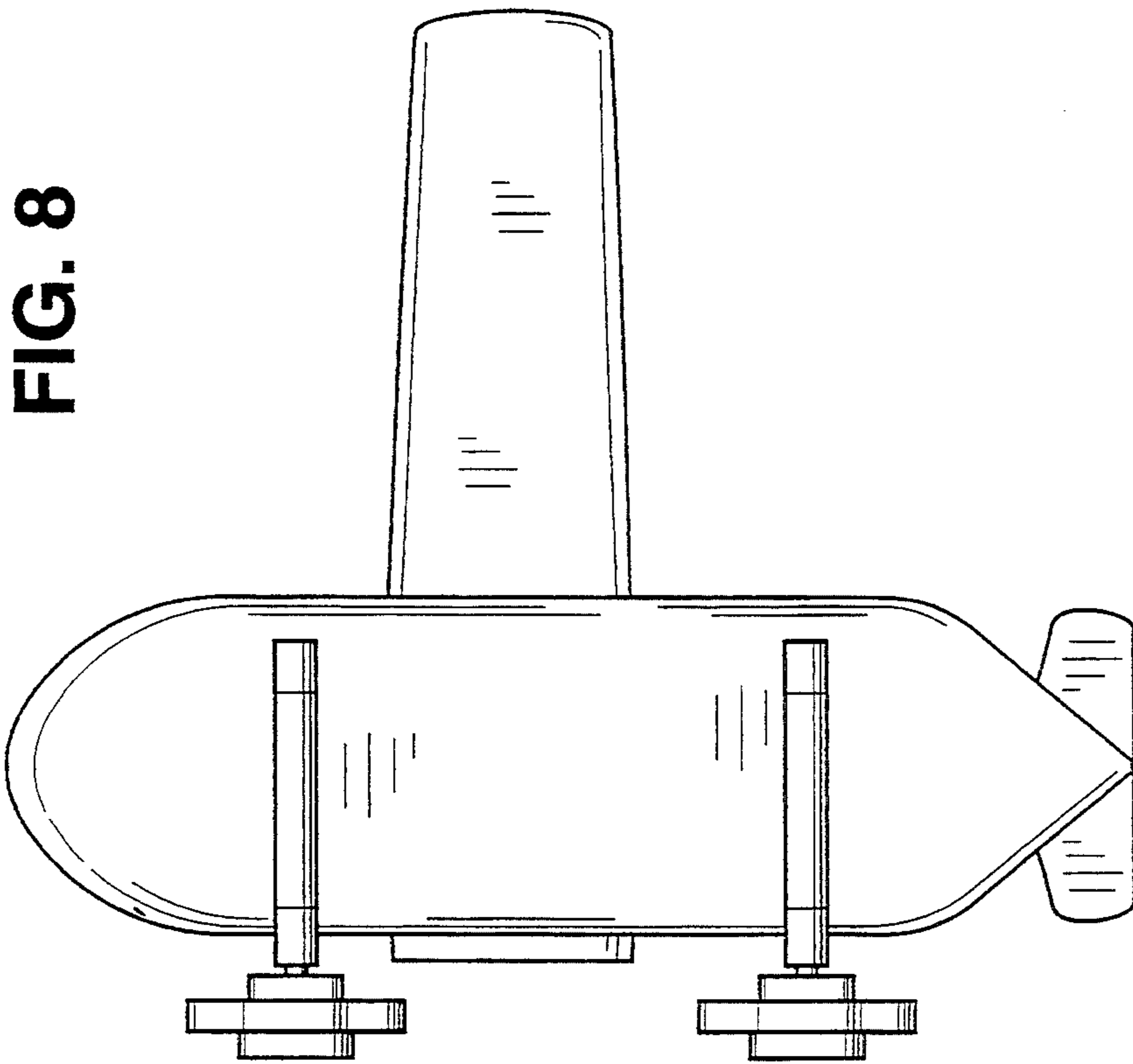

FIG. 8

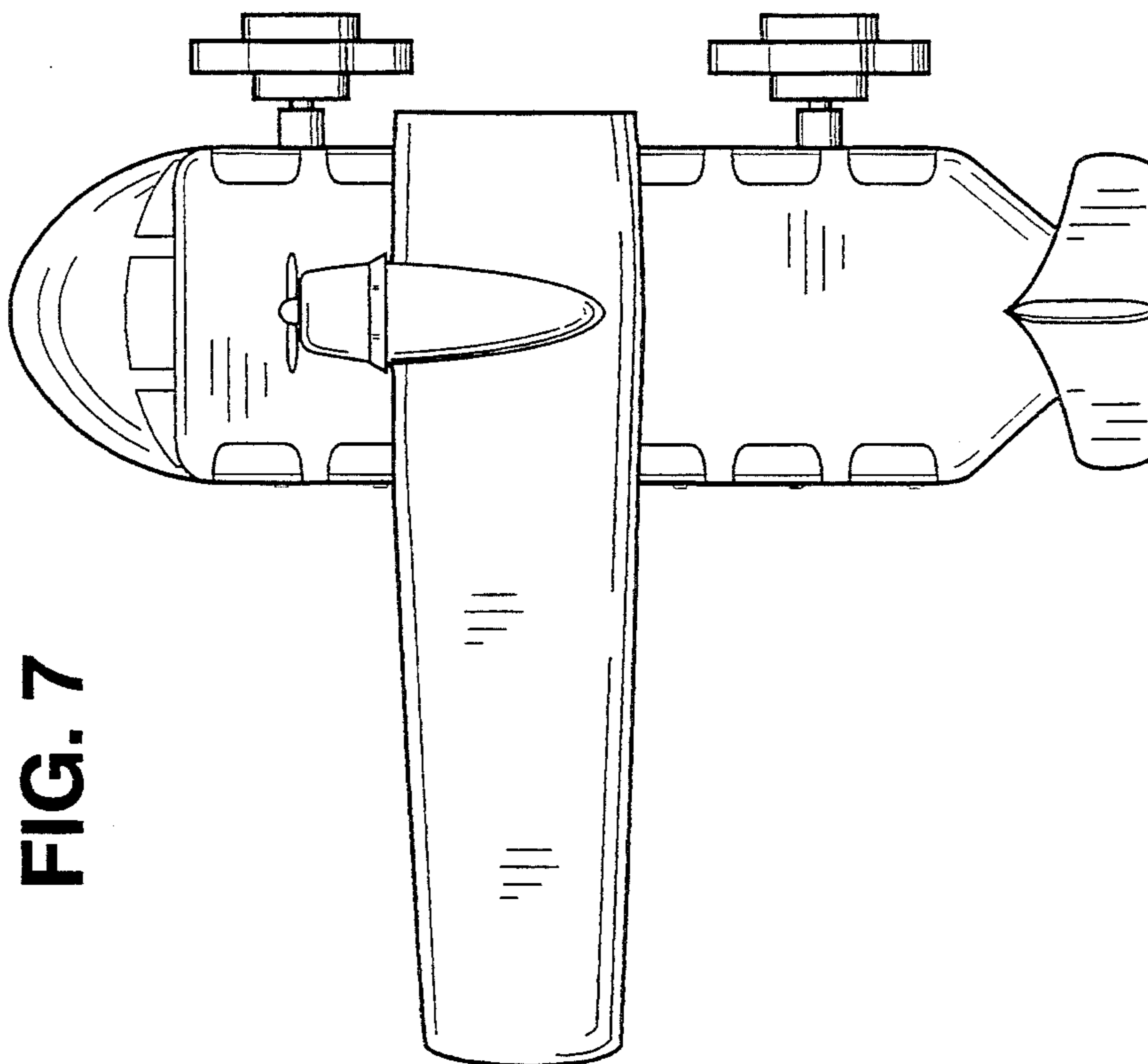

FIG. 7