



US00D361627S

# United States Patent [19]

[11] Patent Number: **Des. 361,627**

Garrard et al.

[45] Date of Patent: **\*\* Aug. 22, 1995**

[54] FUEL REGULATOR

[56] References Cited

### U.S. PATENT DOCUMENTS

[75] Inventors: **James H. Garrard**, Kirkwood; **Eric A. Stenborg**, High Ridge; **Mark A. Jones**, St. Louis, all of Mo.

D. 215,001 8/1969 Hammon ..... D23/235  
D. 311,437 10/1990 Datta et al. .... D10/49 X  
D. 314,348 2/1991 Sergi ..... D10/49

[73] Assignee: **Essex Industries, Inc.**, St. Louis, Mo.

*Primary Examiner*—Stella Reid  
*Assistant Examiner*—Eric Watterson  
*Attorney, Agent, or Firm*—Kalish & Gilster

[\*\*] Term: **14 Years**

[57] CLAIM

The ornamental design for a fuel regulator, as shown and described.

[21] Appl. No.: **24,433**

### DESCRIPTION

[22] Filed: **Jun. 14, 1994**

[52] U.S. Cl. .... **D23/235**

[58] Field of Search ..... **D23/233-237,**  
**D23/244-249; 137/88, 114, 118, 233, 614.02;**  
**123/445, DIG. 10, 340, 382; D10/49**

FIG. 1 is an isometric view showing our new design; FIG. 2 is an elevational end view thereof the opposite elevational end view being a mirror image; FIG. 3 is a side elevational view thereof, the rear view being a mirror image; FIG. 4 is a top plan view thereof; and, FIG. 5 is a bottom plan view thereof.

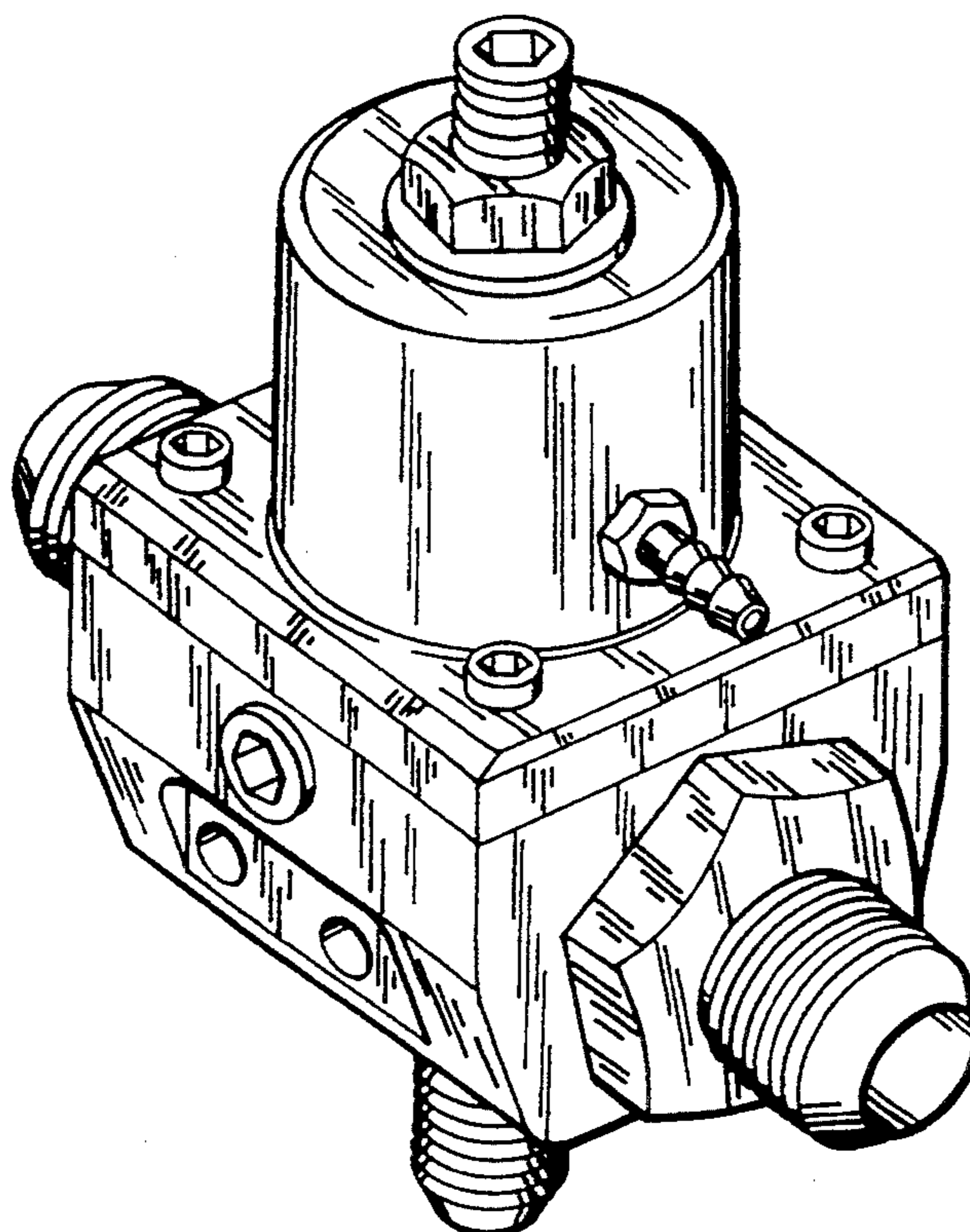

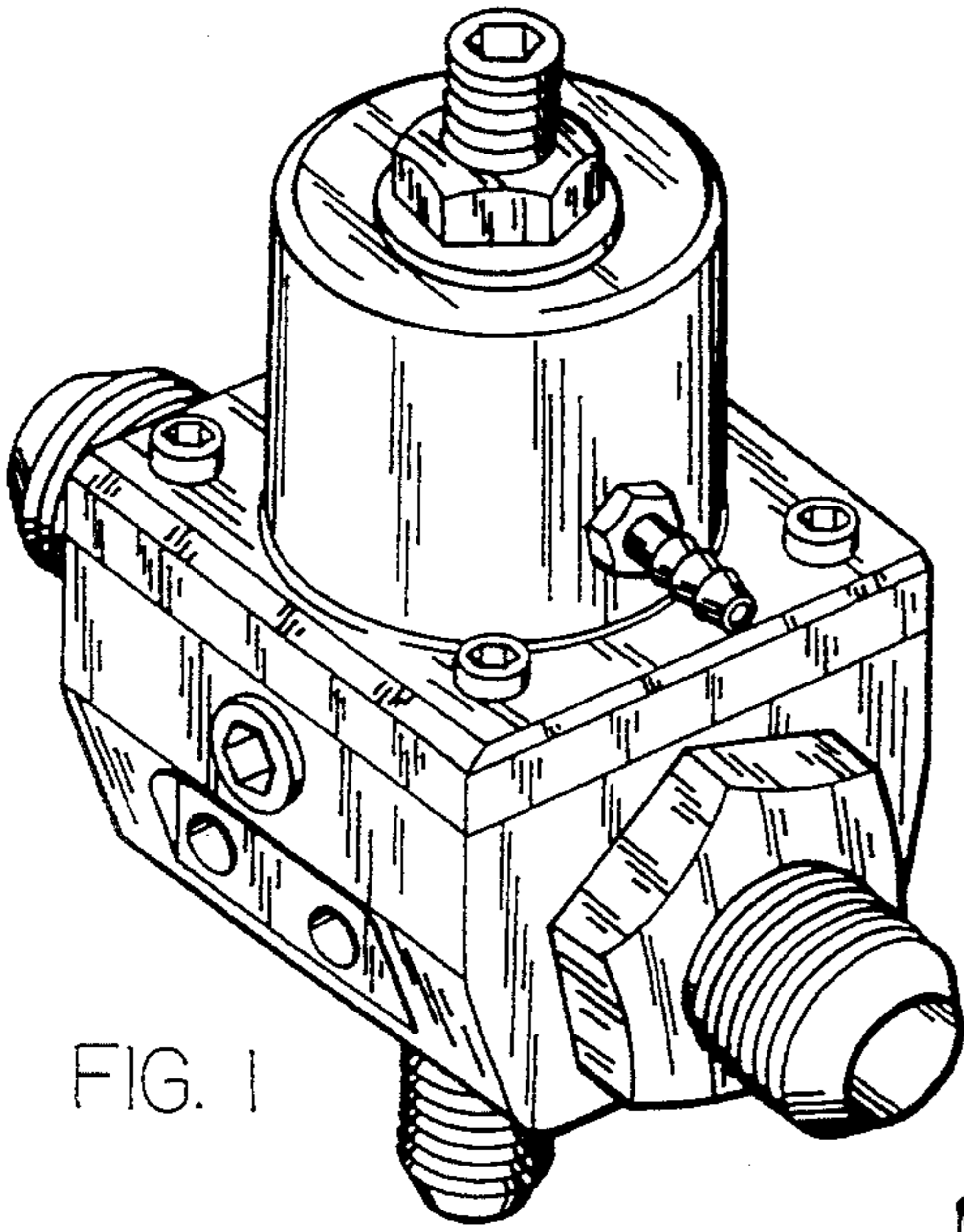

FIG. 1

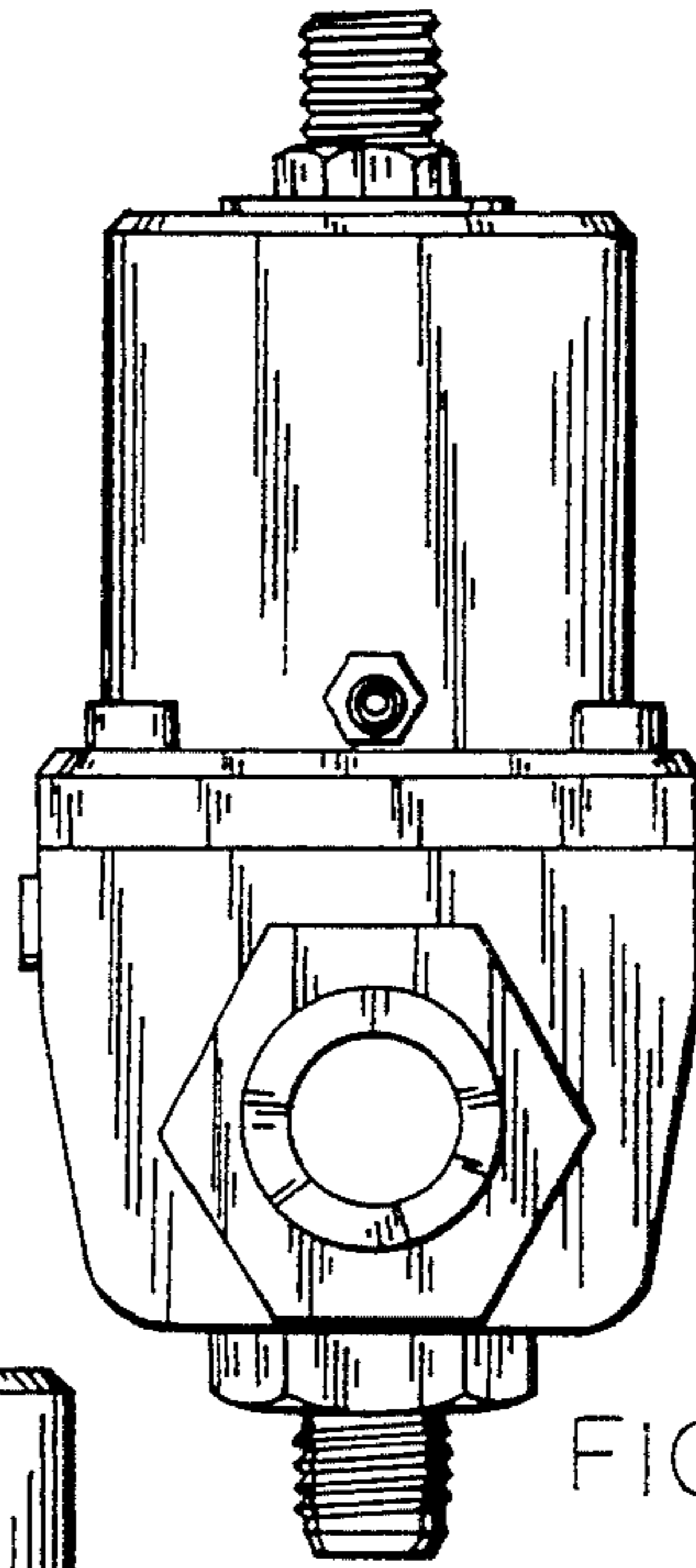

FIG. 2

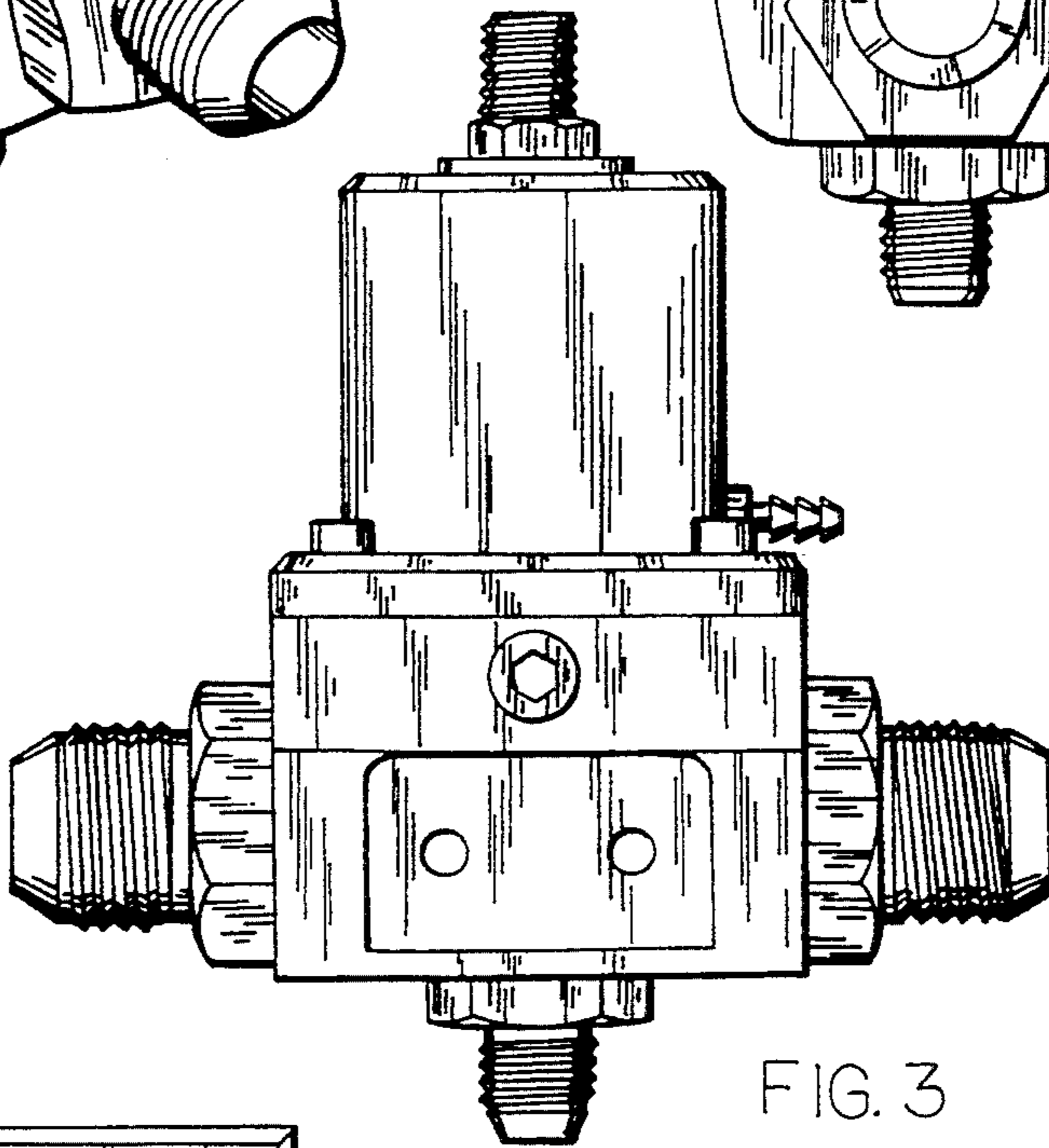

FIG. 3

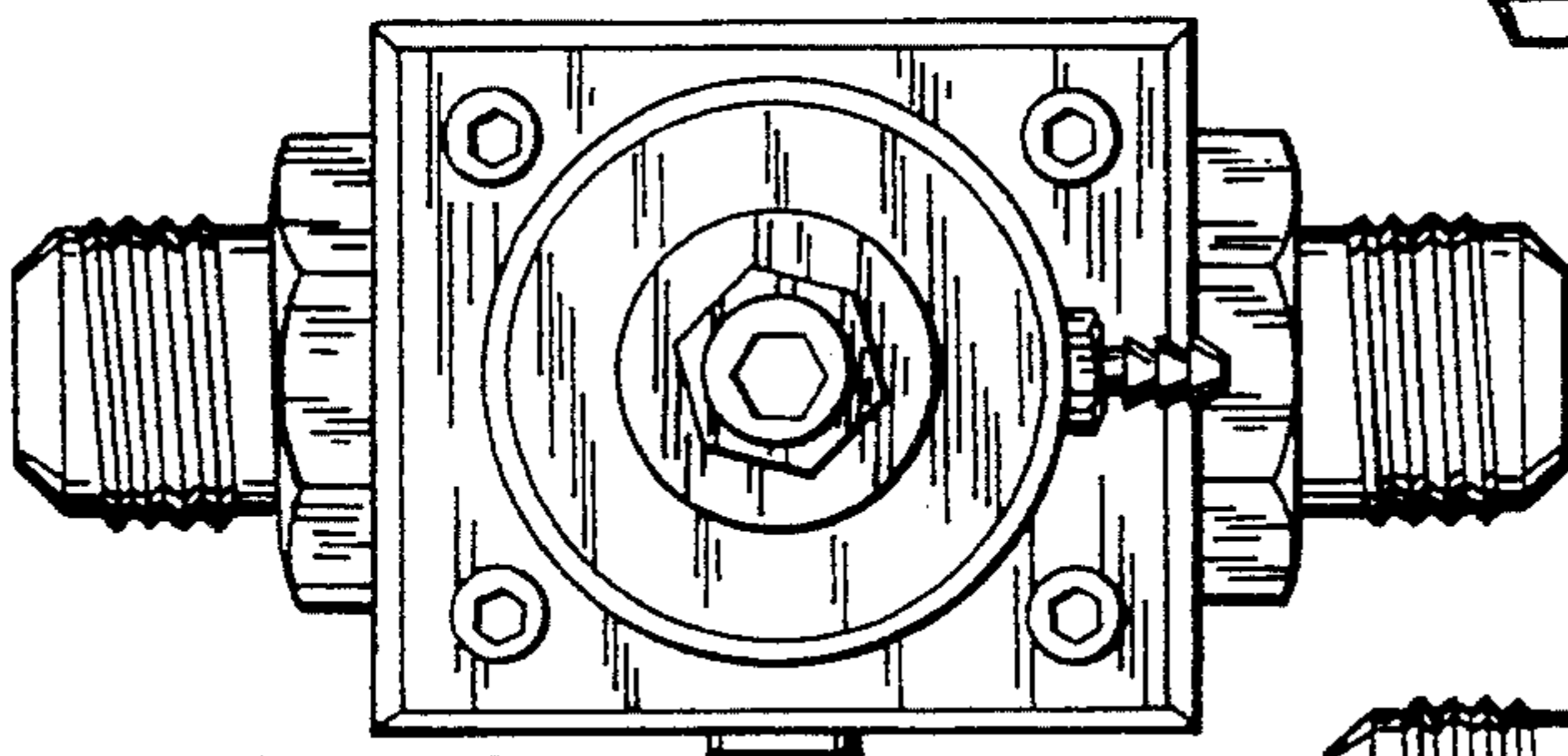

FIG. 4

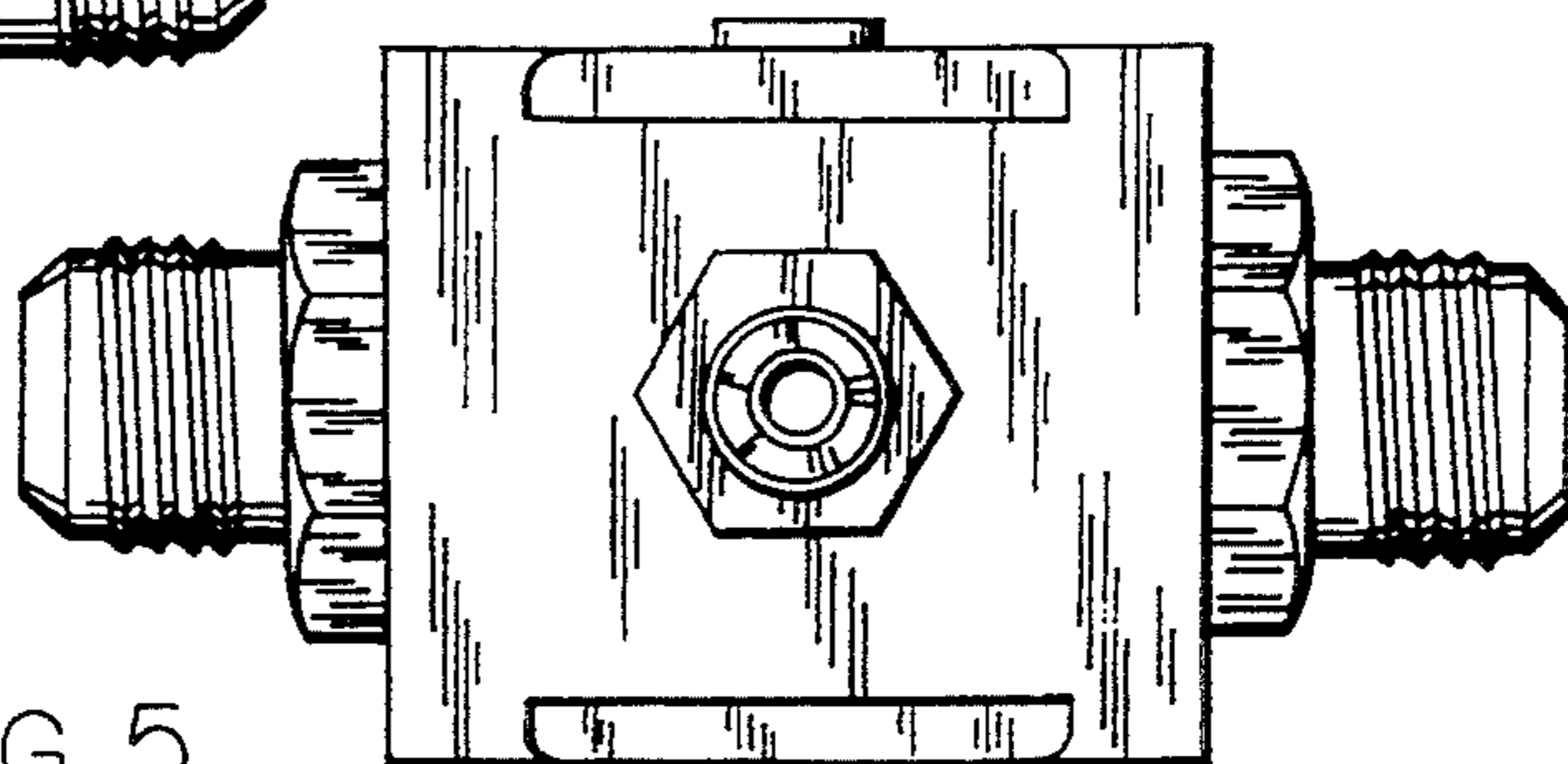

FIG. 5