



US00D361476S

United States Patent [19]

[11] Patent Number: **Des. 361,476**

Bidwell

[45] Date of Patent: **** Aug. 22, 1995**

[54] SET OF COASTERS

[57] CLAIM

[76] Inventor: **Christopher C. Bidwell**, 1009 Dunbar Dr., Dunwoody, Ga. 30338

The ornamental design for a set of coasters, as shown and described.

[**] Term: **14 Years**

DESCRIPTION

[21] Appl. No.: **21,834**

FIG. 1 is a top, front perspective view of a set of coasters showing my new design;
 FIG. 2 is a top plan view thereof;
 FIG. 3 is a bottom plan view thereof;
 FIG. 4 is a front elevation view thereof;
 FIG. 5 is a cross-sectional view thereof taken along line 5—5 of FIG. 2;
 FIG. 6 is an exploded front perspective view thereof;
 FIG. 7 is a bottom plan view taken along line 7—7 of FIG. 6;
 FIG. 8 is a top plan view taken along line 8—8 of FIG. 6;
 FIG. 9 is a bottom plan view taken along line 9—9 of FIG. 6;
 FIG. 10 is a top plan view taken along line 10—10 of FIG. 6;
 FIG. 11 is a bottom plan view taken along line 11—11 of FIG. 6;
 FIG. 12 is a top plan view taken along line 12—12 of FIG. 6;
 FIG. 13 is a bottom plan view taken along line 14—14 of FIG. 6;
 FIG. 14 is a top plan view taken along line 15—15 of FIG. 6;
 FIG. 15 is a bottom plan view taken along line 15—15 of FIG. 6;
 FIG. 16 is a top plan view taken along line 16—16 of FIG. 6;
 FIG. 17 is an exploded front elevation view thereof;
 FIG. 18 is an exploded rear elevation view thereof; and,
 FIG. 19 is a cross-sectional view taken along line 19—19 of FIG. 2.

[22] Filed: **Apr. 25, 1994**

[52] U.S. Cl. **D7/625; D9/347; D9/518**

[58] Field of Search **D7/624-625; D9/341, 347, 518; 206/509; 211/194; 215/100.5; 220/4.26, 4.27, 23.6, 906, 907, 445; 248/159, 346, 346.1, 908**

[56] References Cited

U.S. PATENT DOCUMENTS

| | | | |
|------------|---------|----------------------|-------------|
| Re. 29,415 | 9/1977 | Ricobene et al. | 206/550 |
| D. 166,368 | 4/1952 | Wenander . | |
| D. 229,270 | 11/1973 | Press | D7/624 |
| D. 236,576 | 9/1975 | Press | D7/624 |
| D. 257,419 | 10/1980 | Russell | D7/625 |
| D. 259,758 | 7/1981 | Marquardt | D7/625 |
| 315,917 | 4/1885 | Dean . | |
| 464,494 | 12/1891 | Cline . | |
| 1,886,109 | 11/1932 | Lenfant . | |
| 1,981,627 | 11/1934 | Merriman | 65/53 |
| 2,645,375 | 7/1953 | Topfer | 220/4 |
| 3,013,688 | 12/1961 | Luning | 215/100.5 |
| 3,161,315 | 12/1964 | Braun | 220/4 |
| 3,369,691 | 2/1968 | Wei | 220/4 |
| 4,203,525 | 5/1980 | Okubo | 220/4 |
| 4,981,214 | 1/1991 | Rojas | 206/509 |
| 5,273,182 | 12/1993 | Laybourne | 215/100.5 X |

The undisclosed side views are identical to the rear view. The broken lines of the graphic in FIGS. 1, 4, 6, and 17 are for illustrative purposes only and form no part of the claimed design.

Primary Examiner—Terry A. Wallace
Attorney, Agent, or Firm—Troutman Sanders; Joel S. Goldman; John A. Savio, III

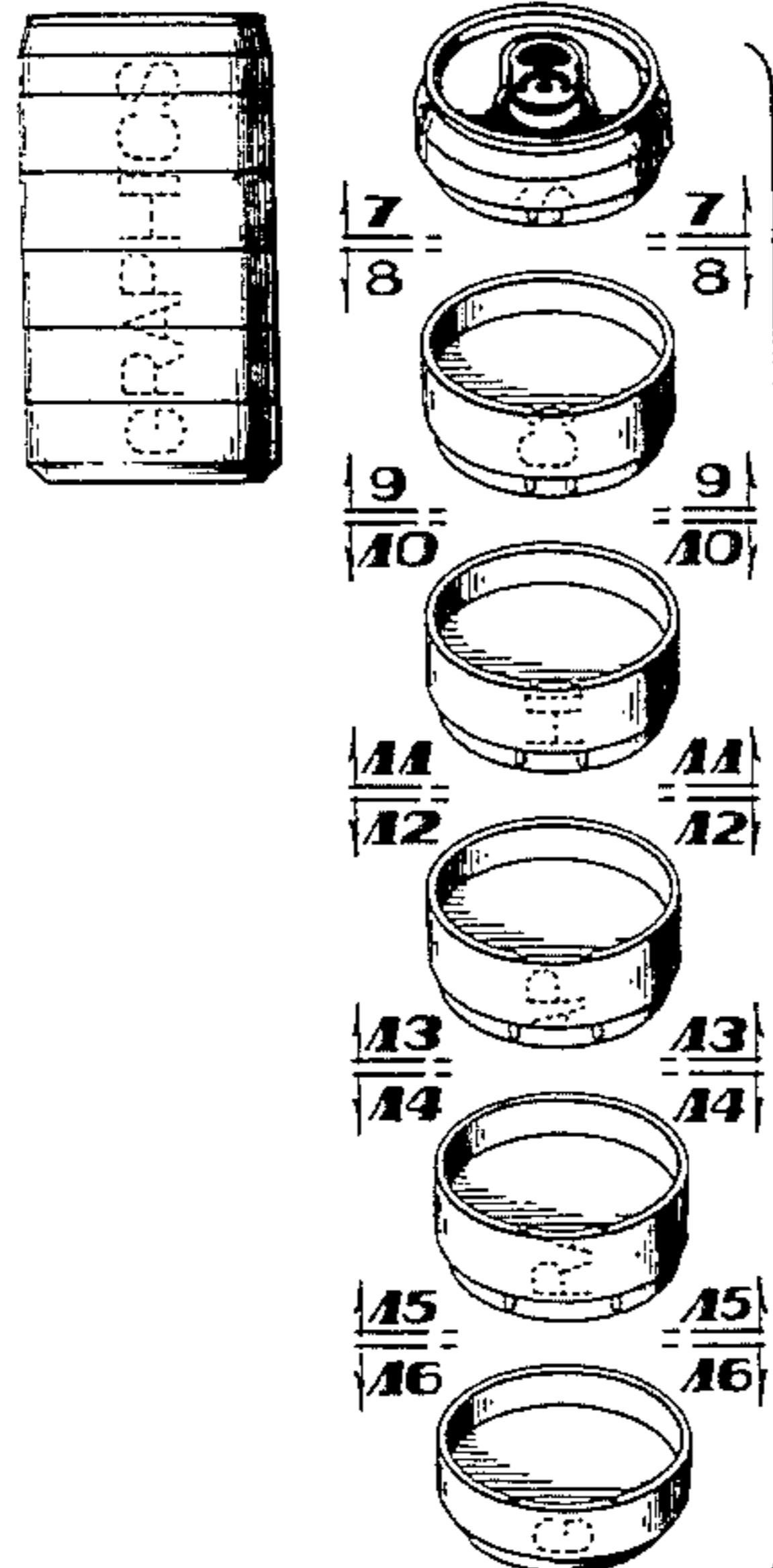

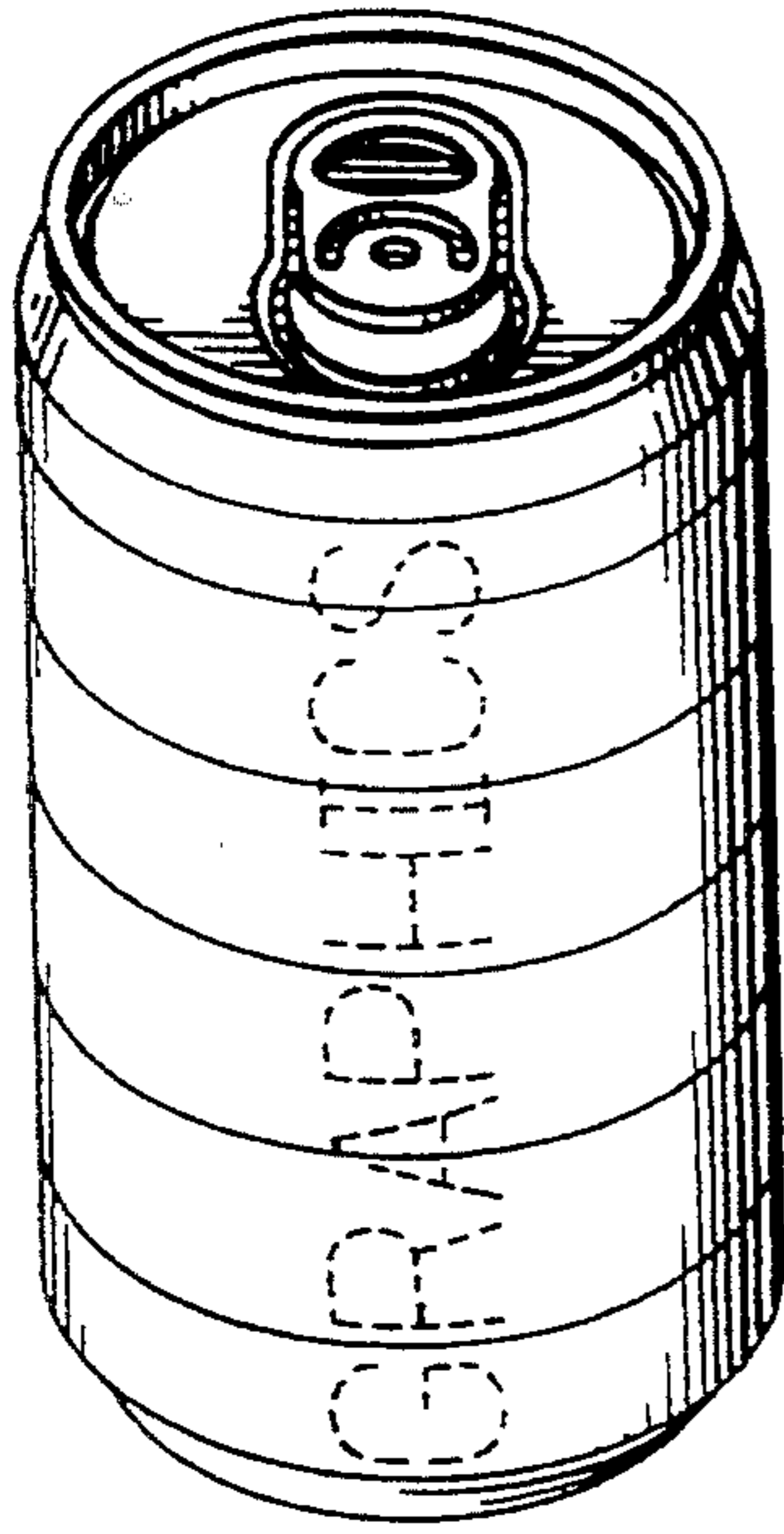

FIG 1

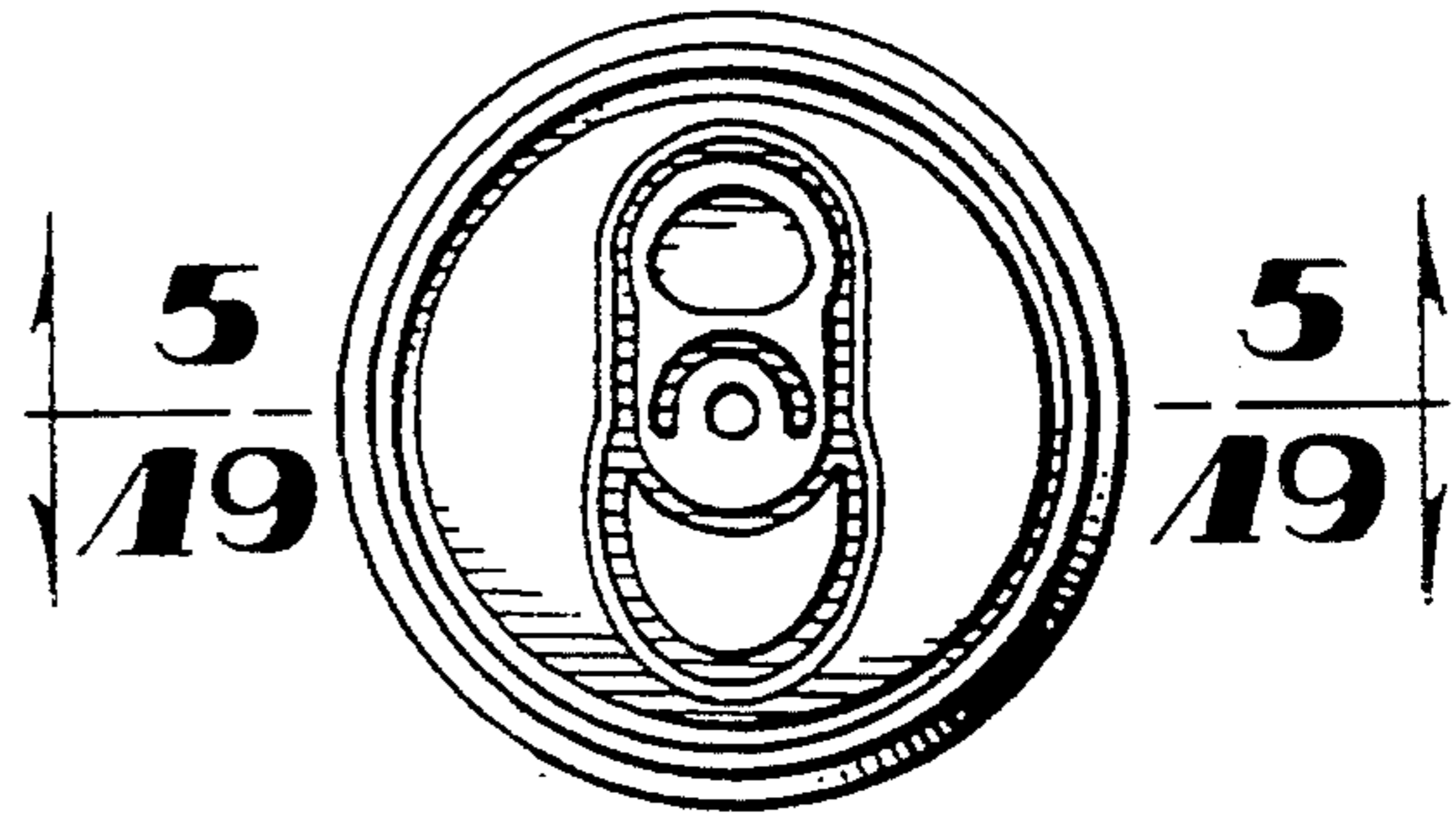

FIG 2

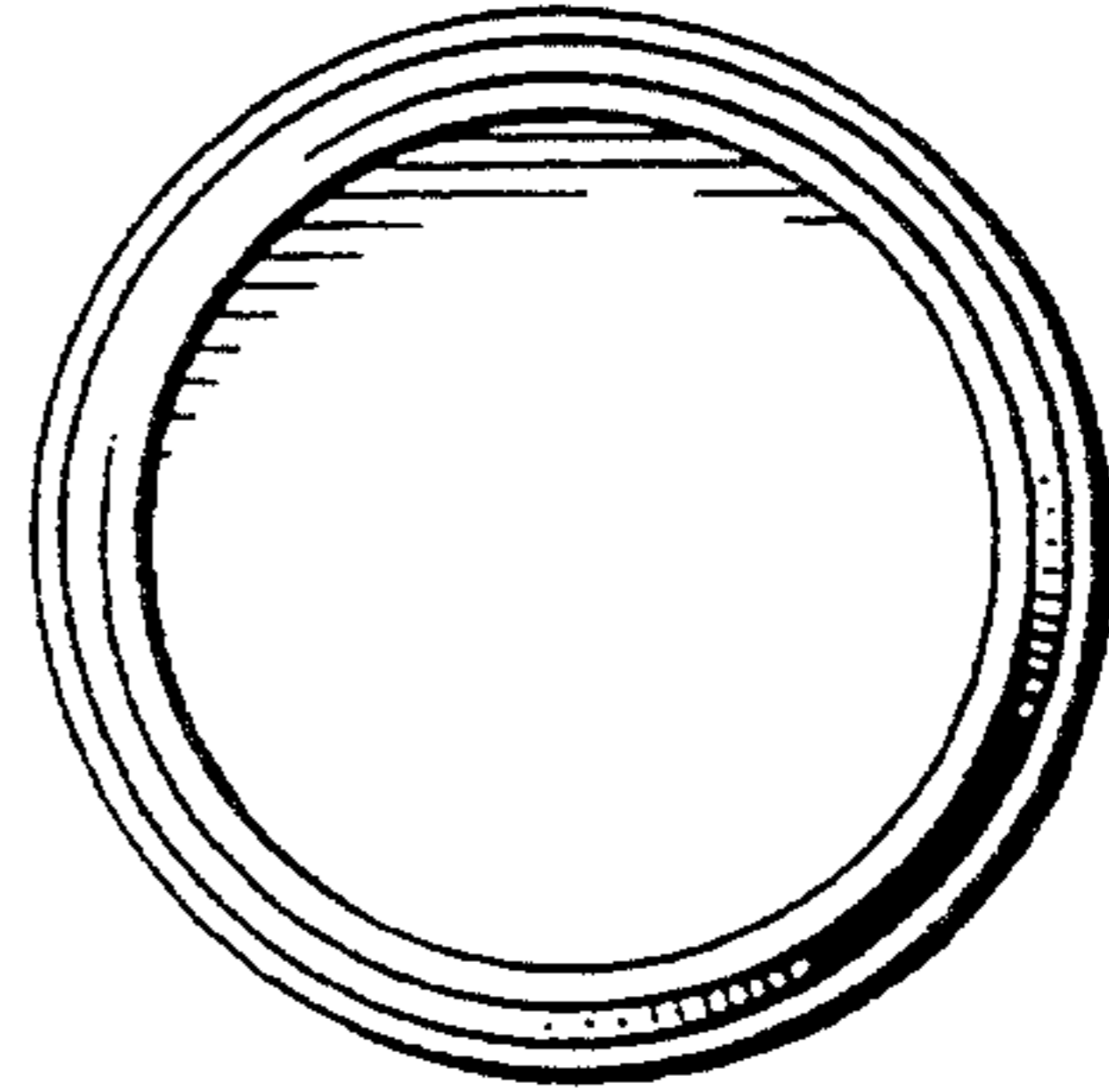

FIG 3

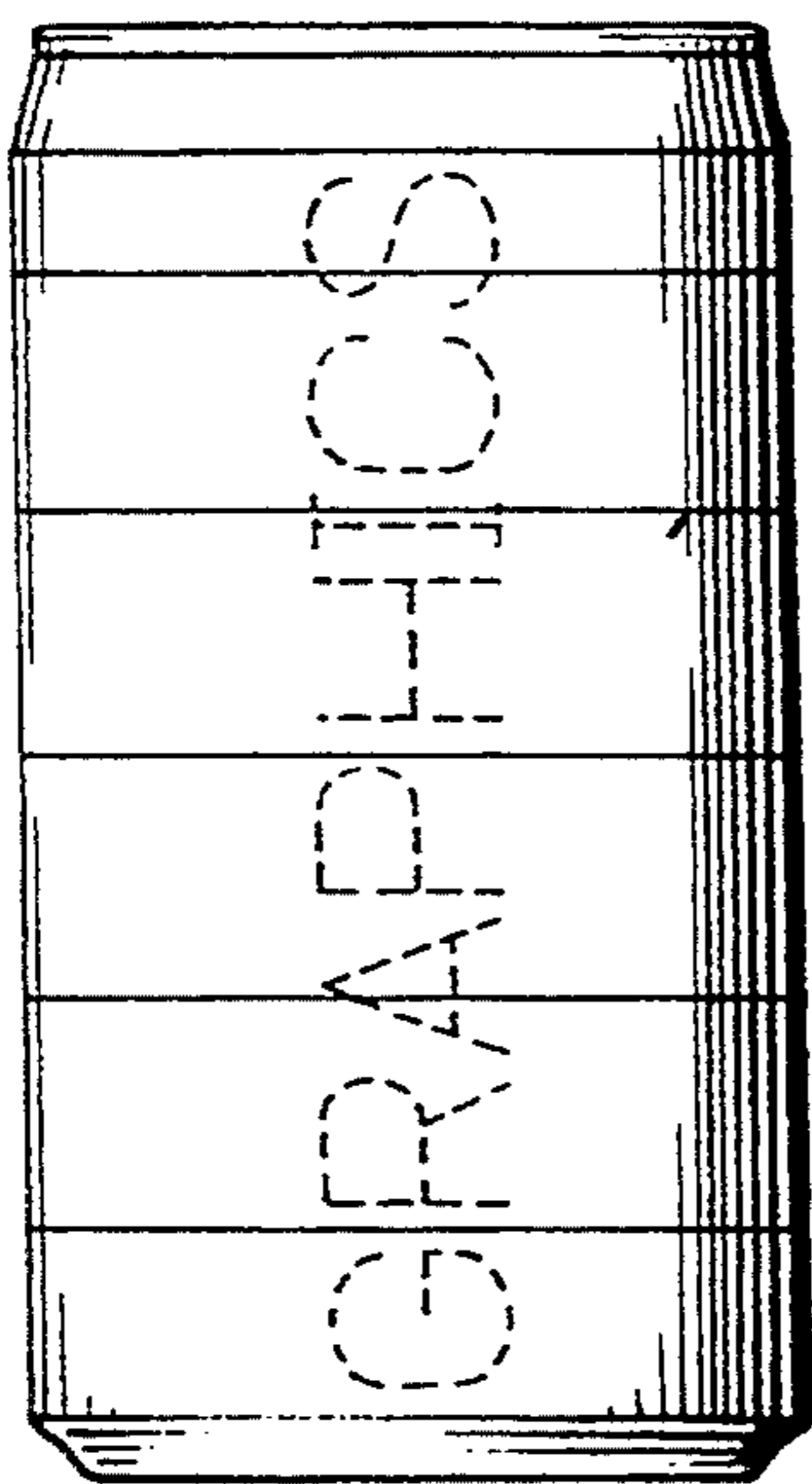

FIG 4

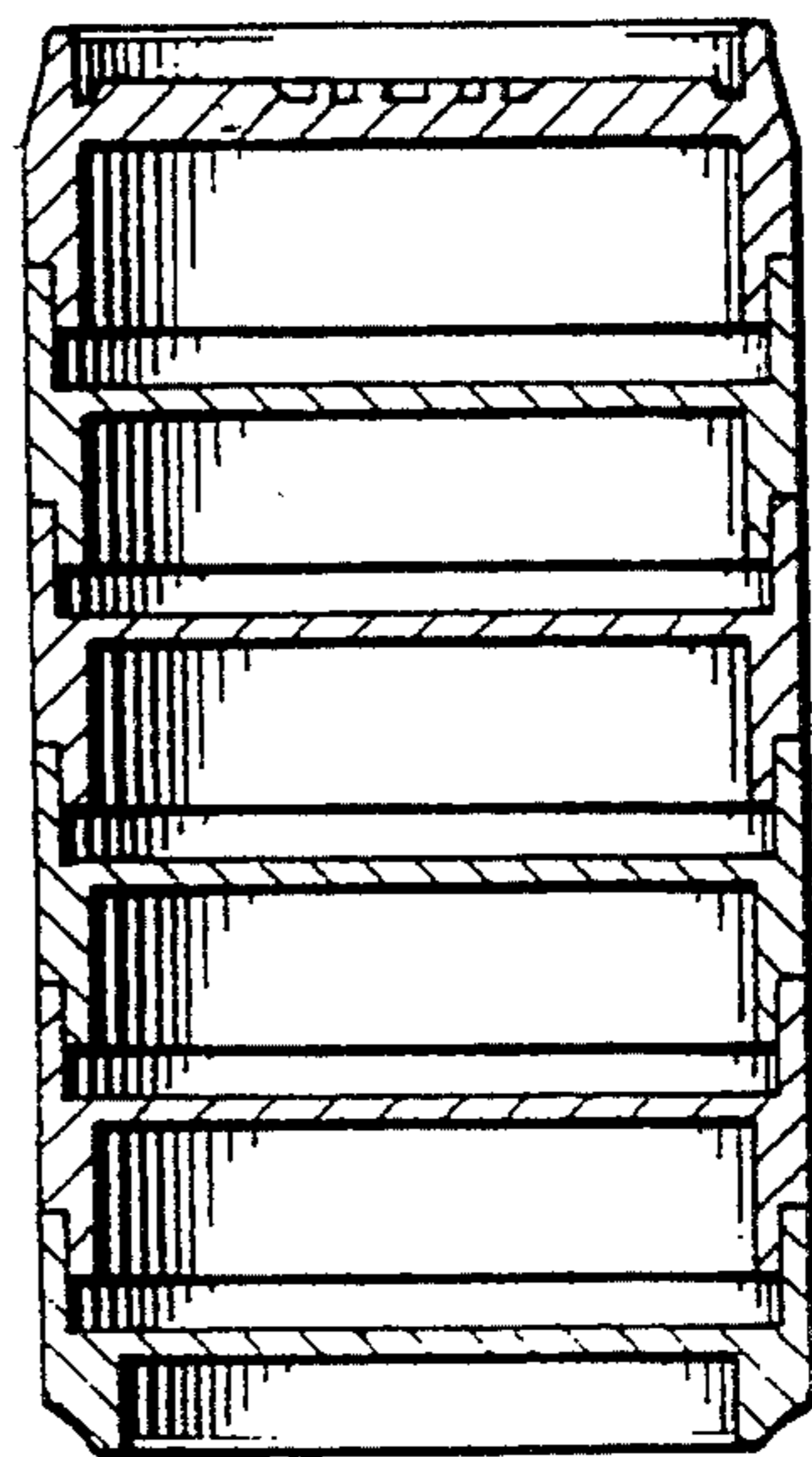

FIG 5

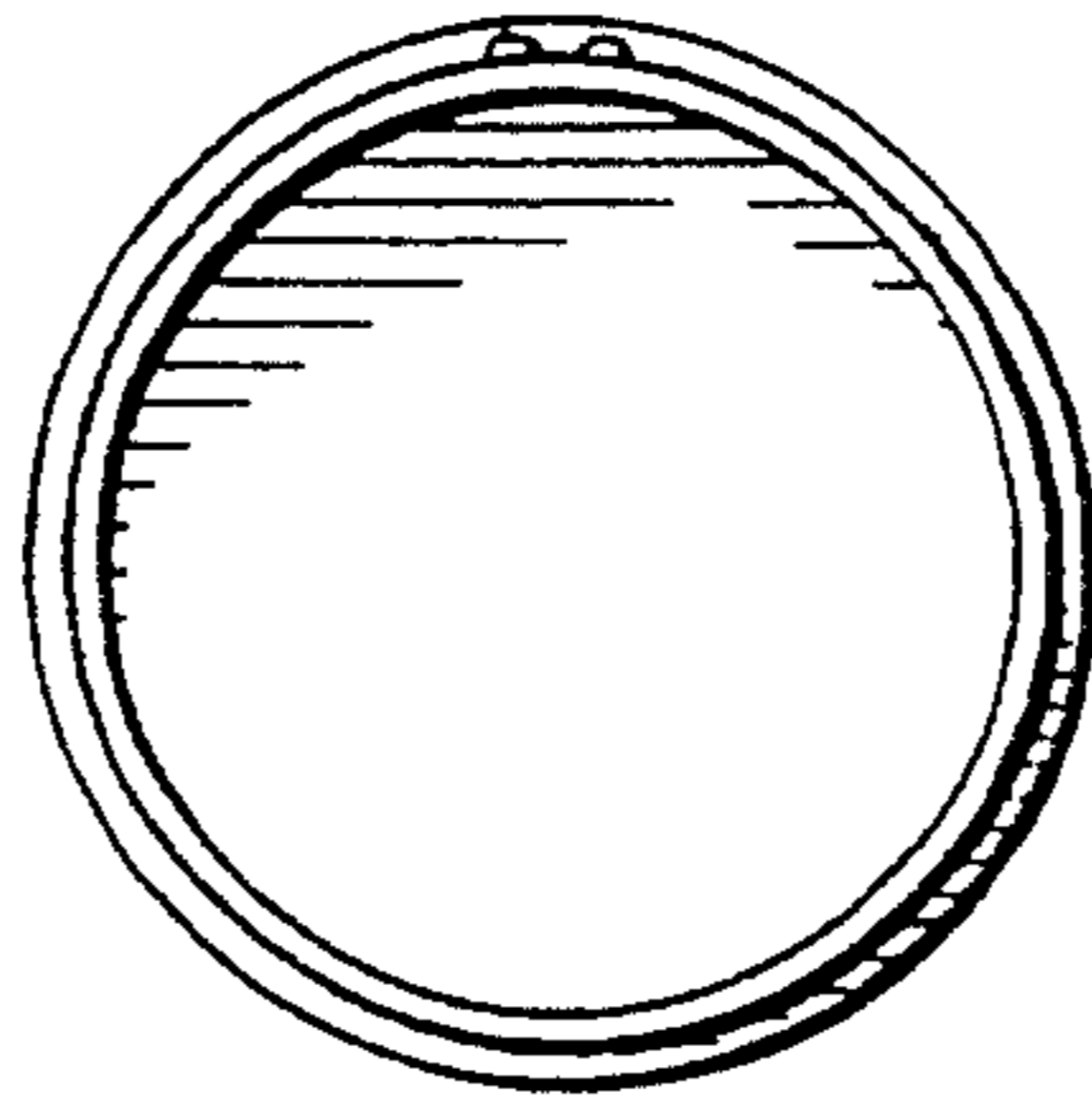
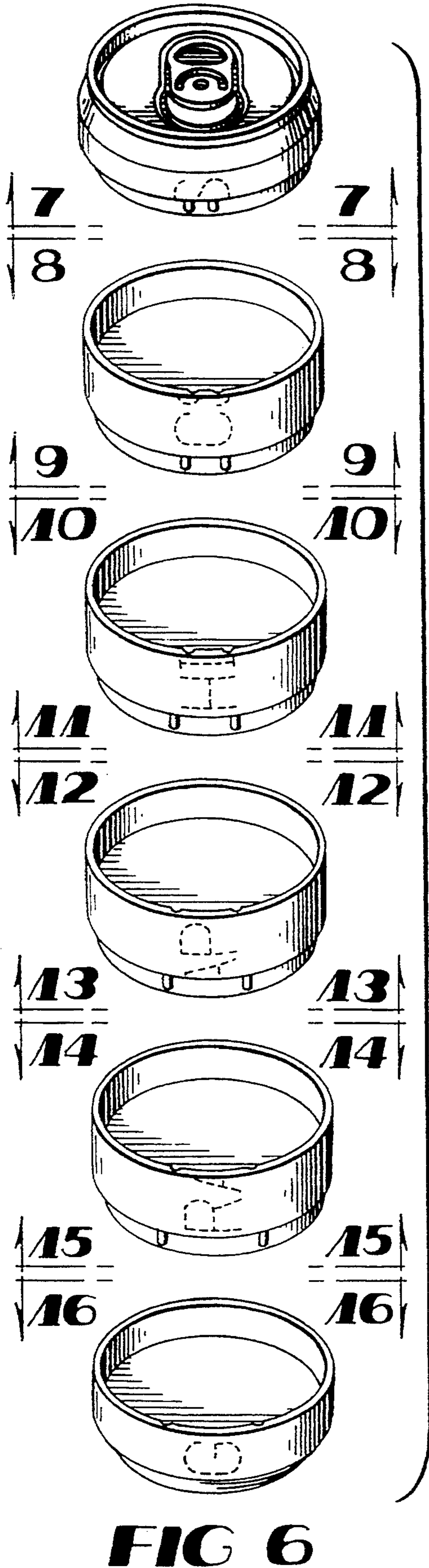

FIG 7

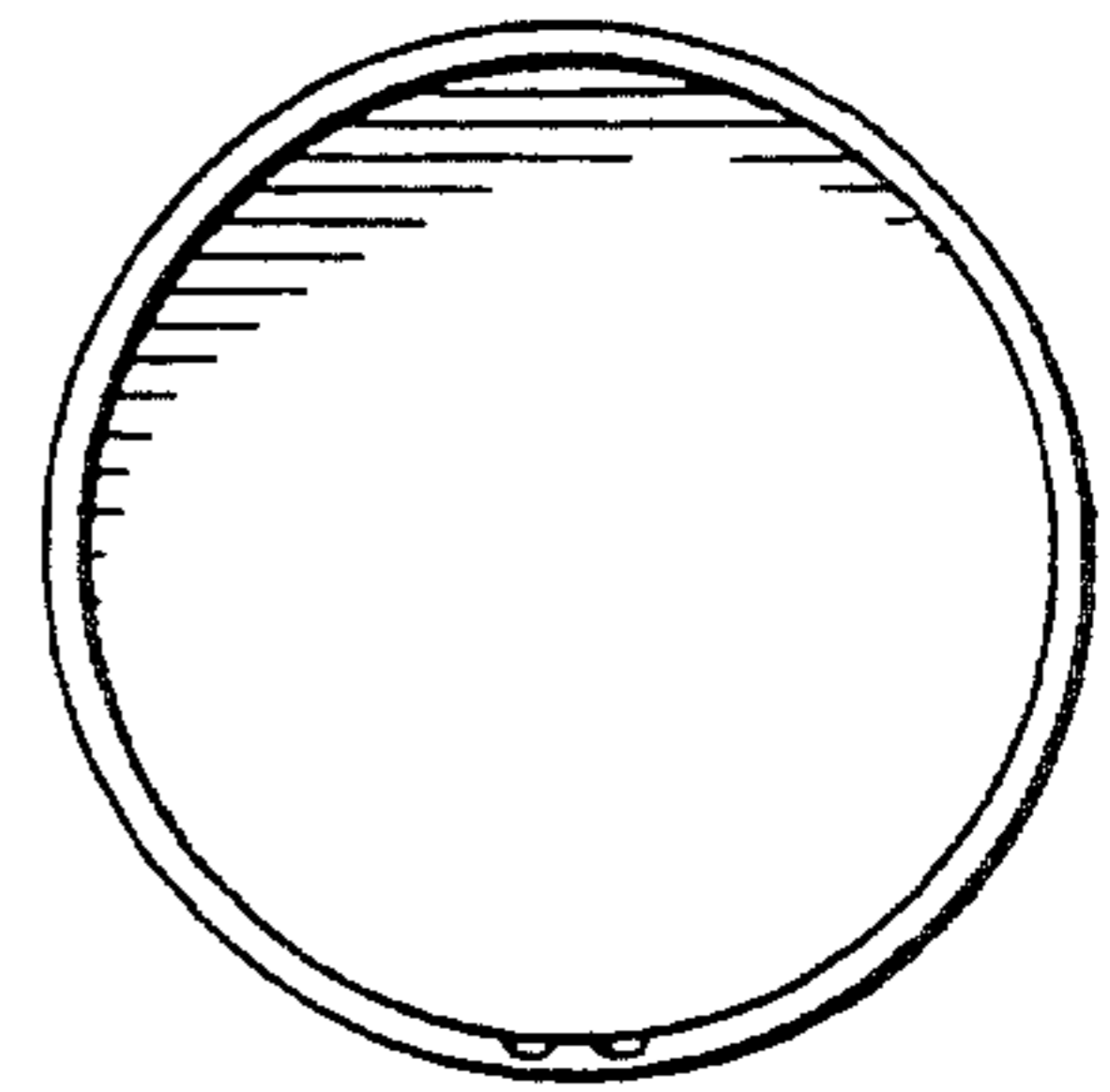

FIG 8

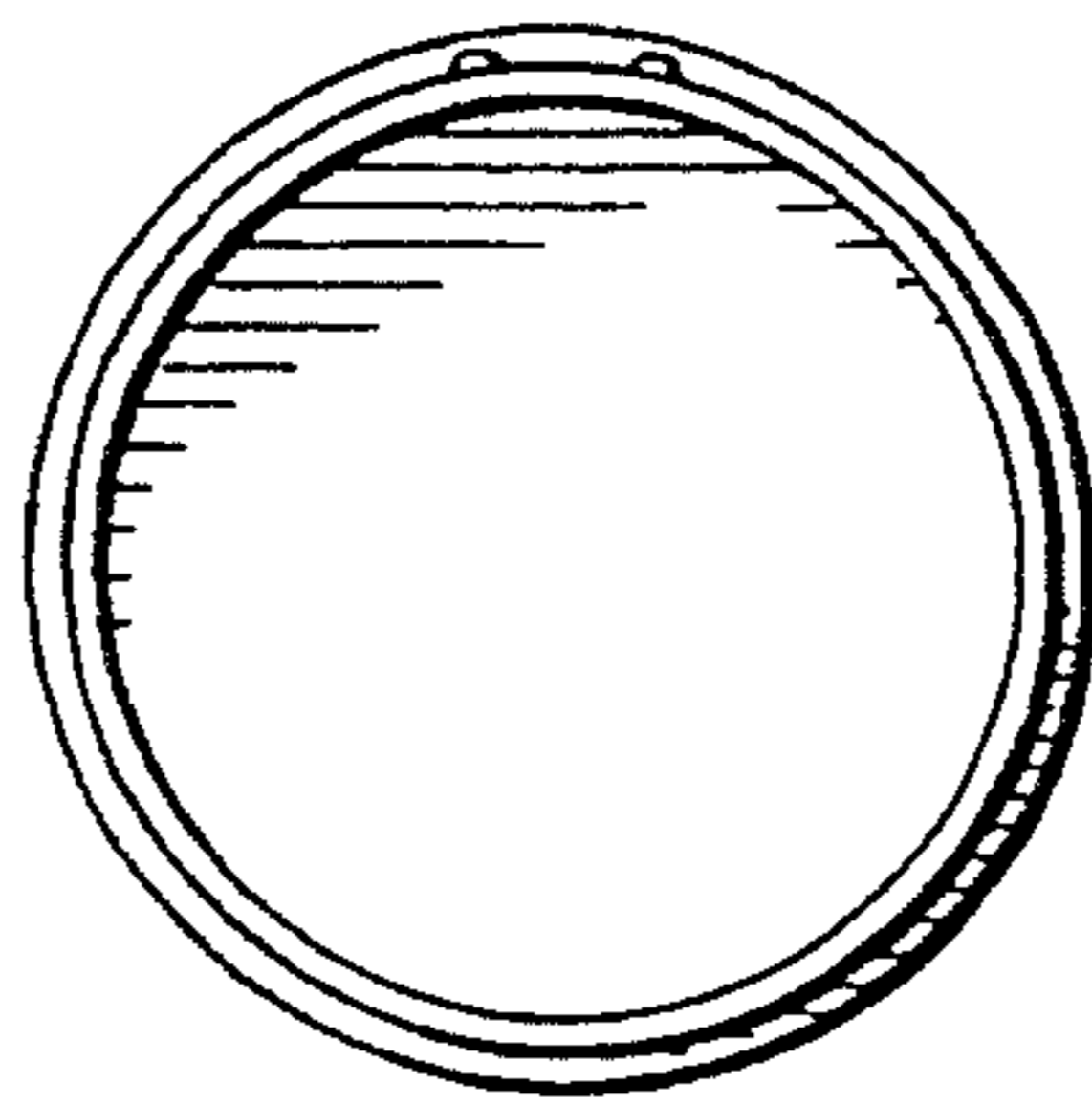

FIG 9

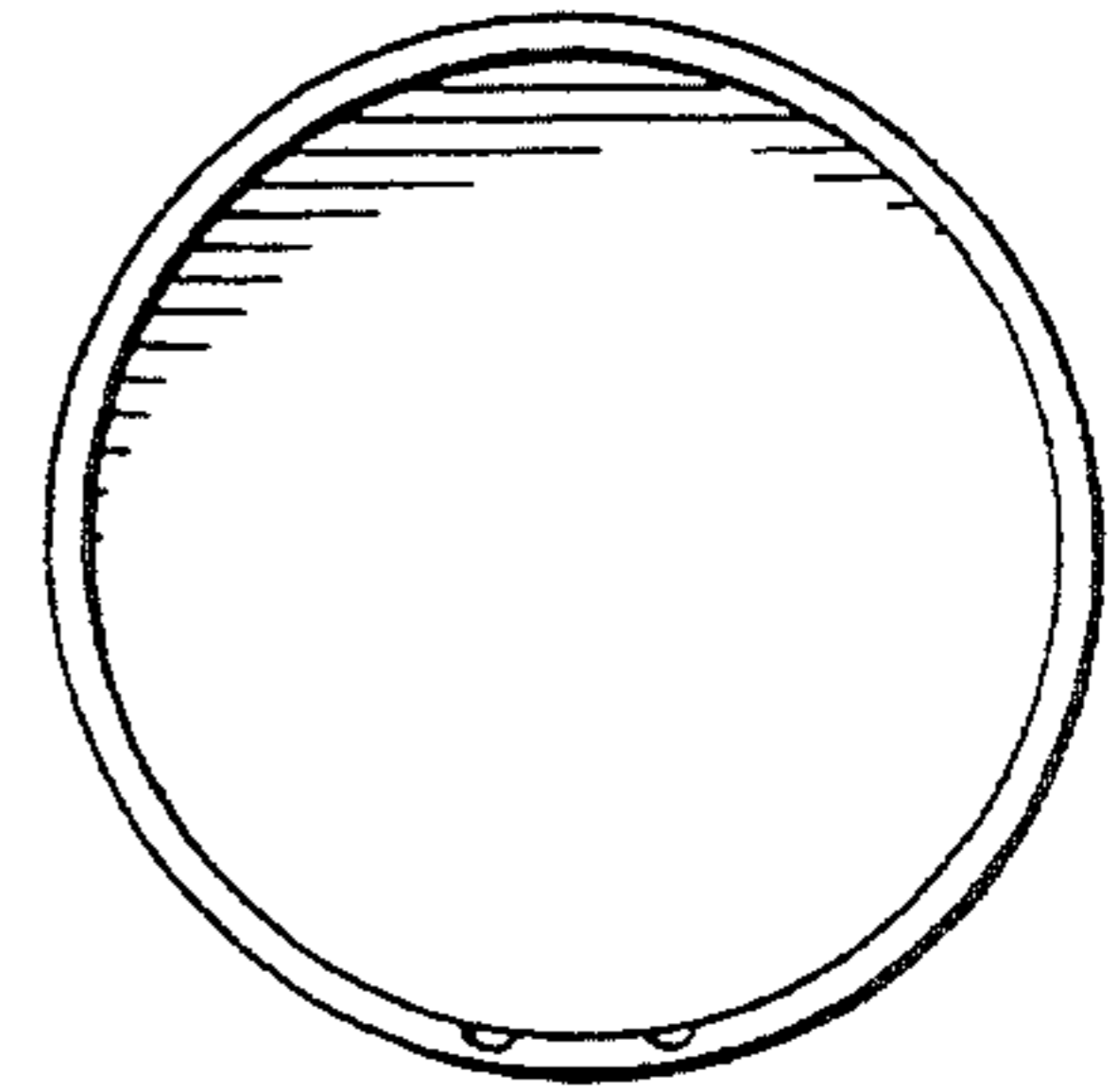

FIG 10

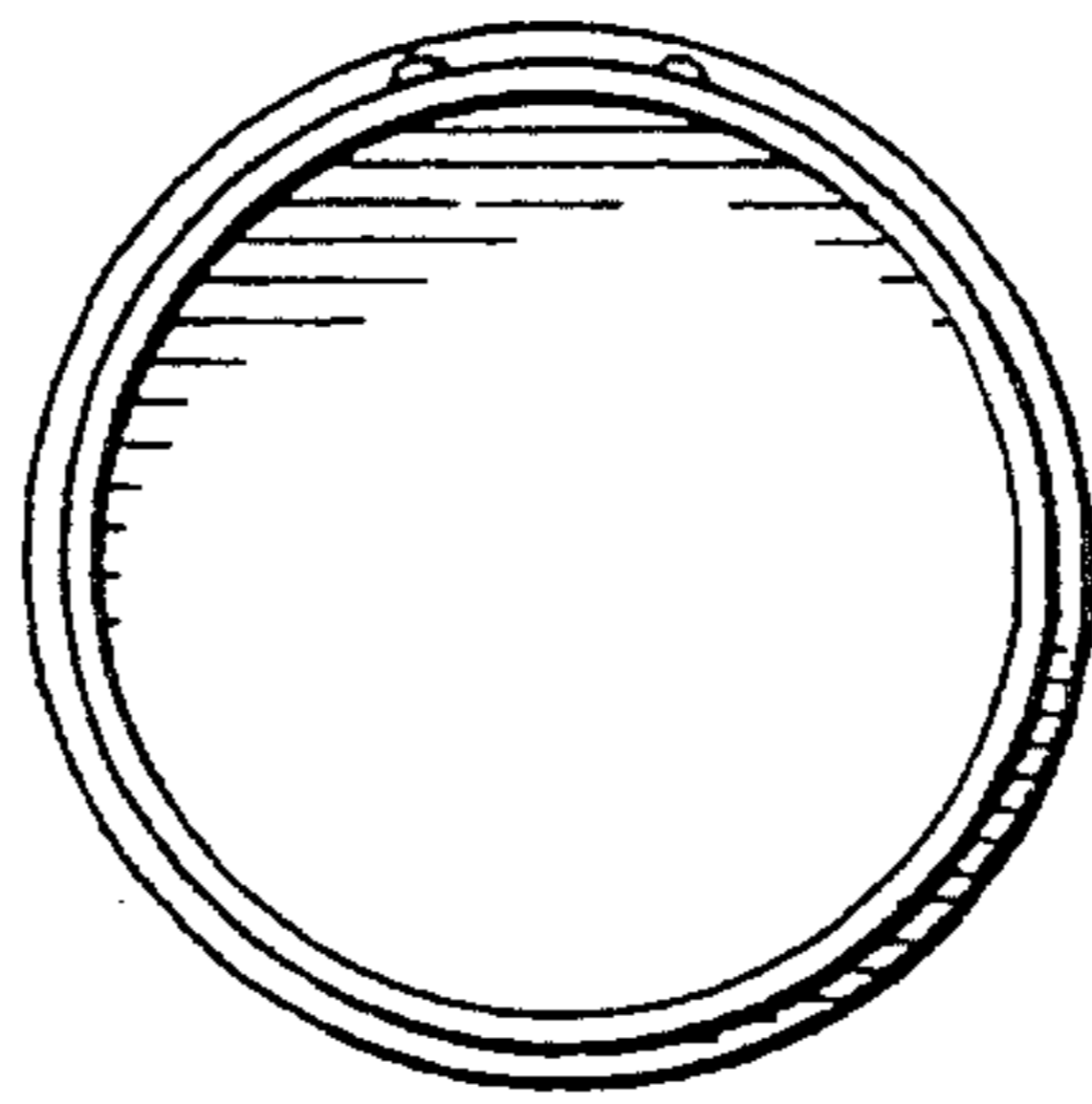

FIG 11

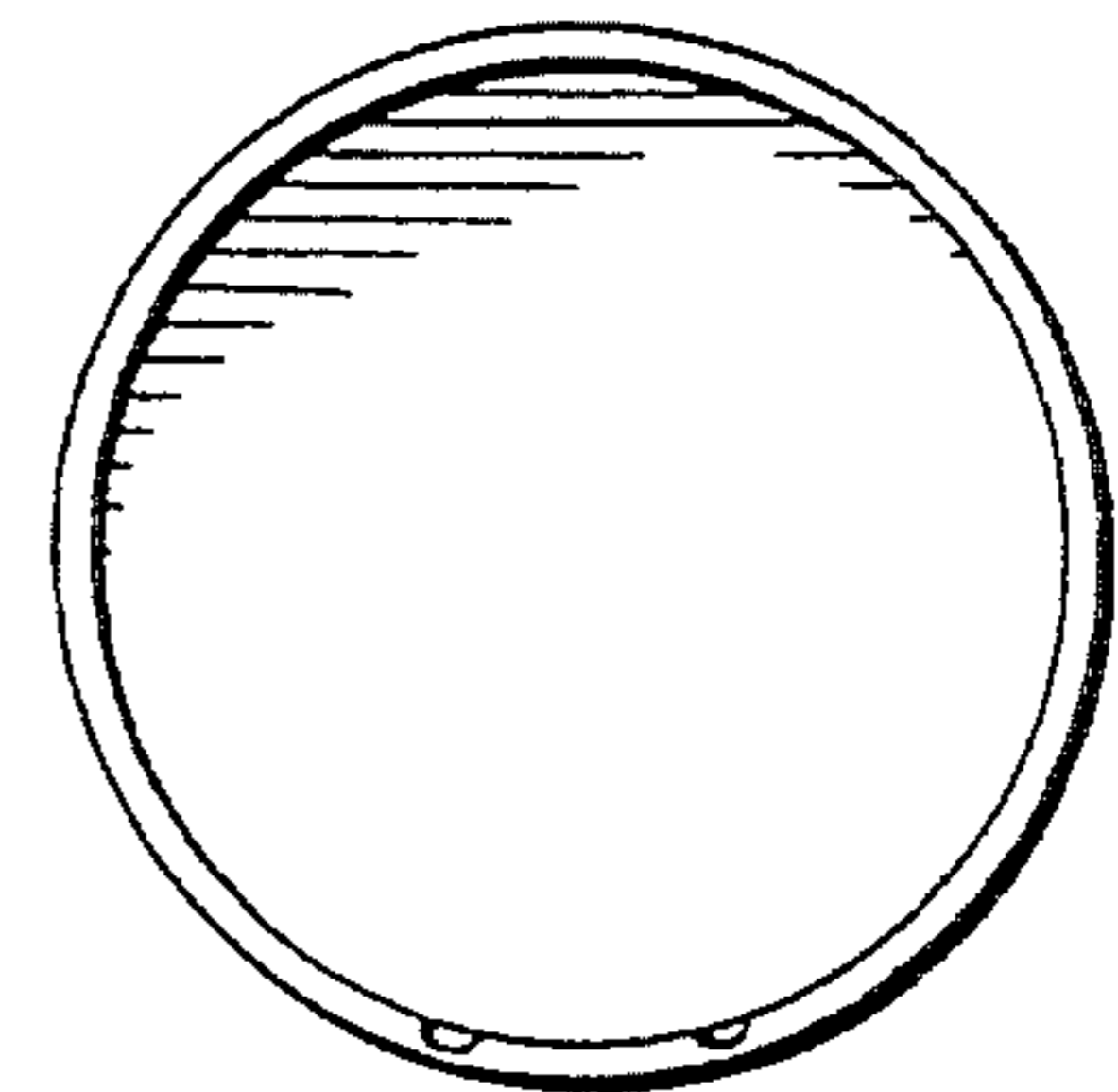

FIG 12

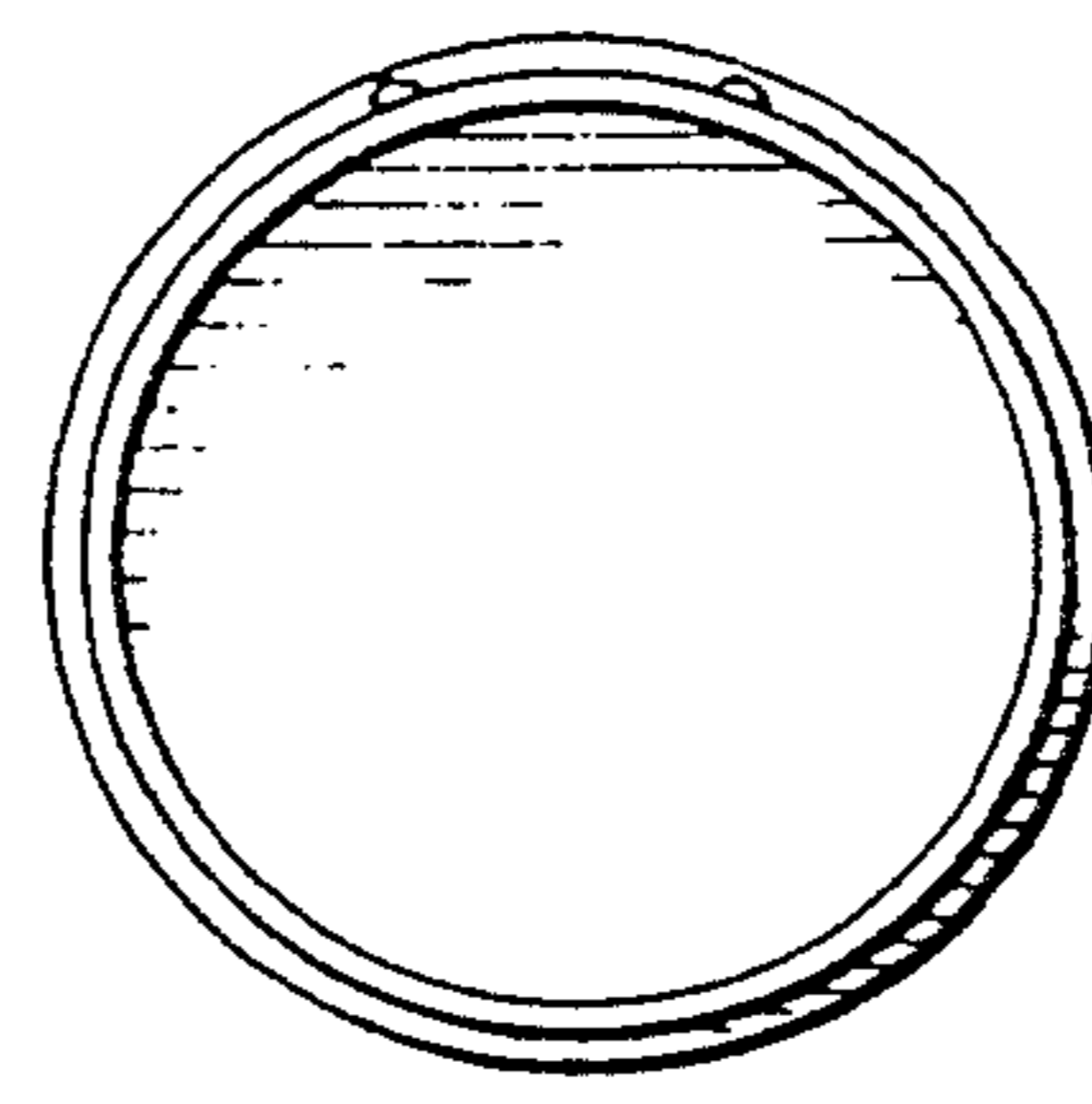

FIG 13

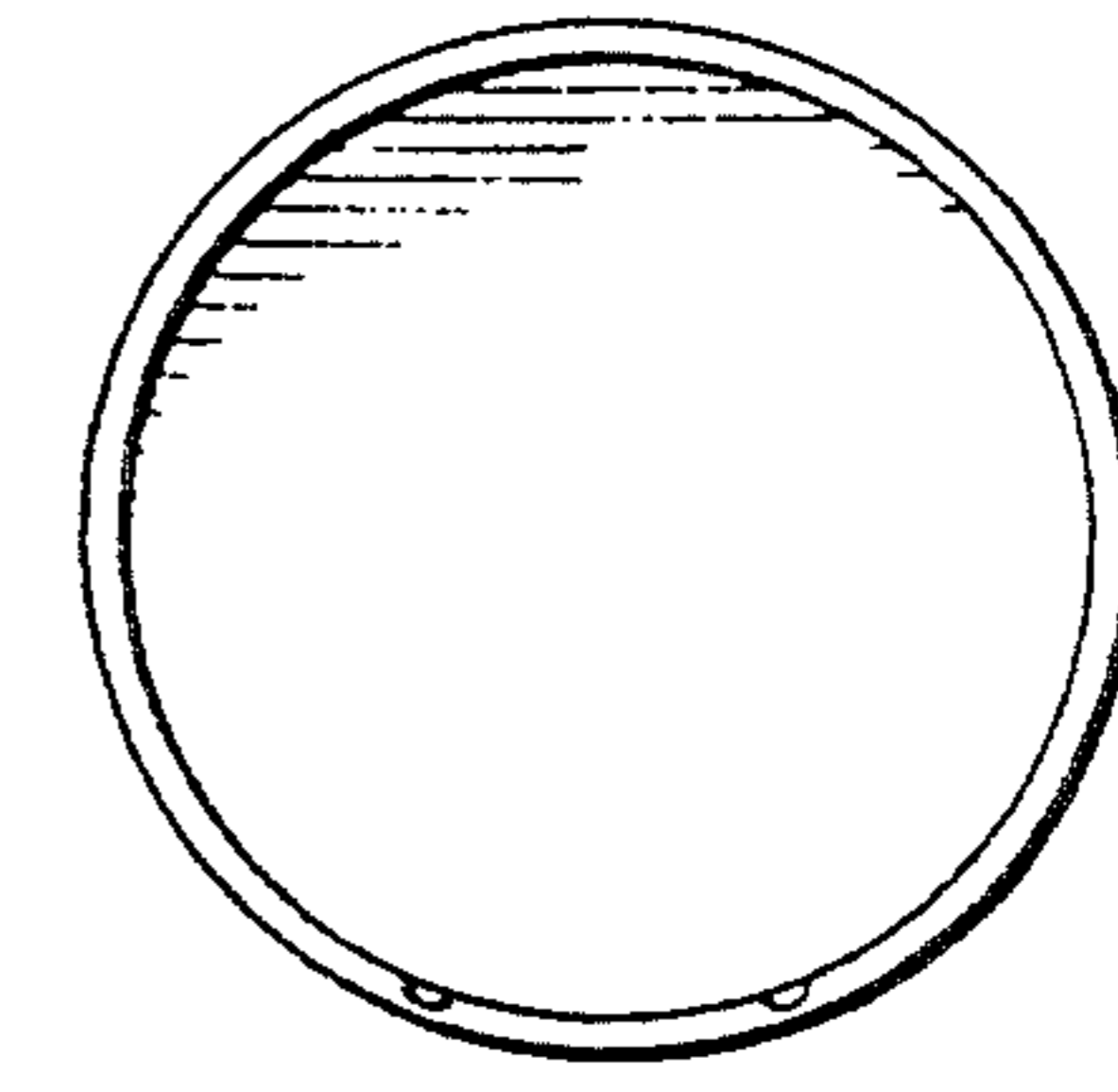

FIG 14

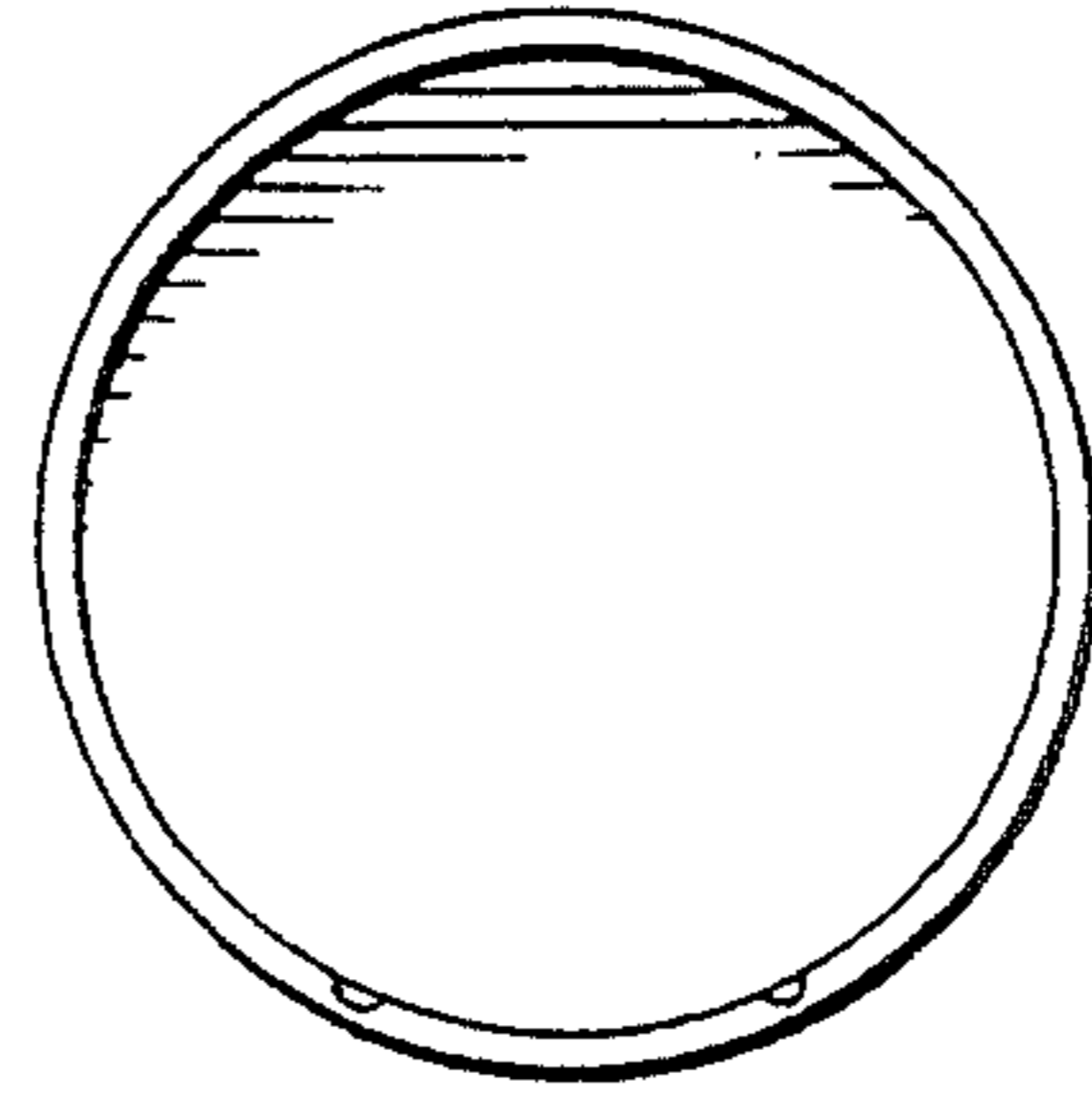
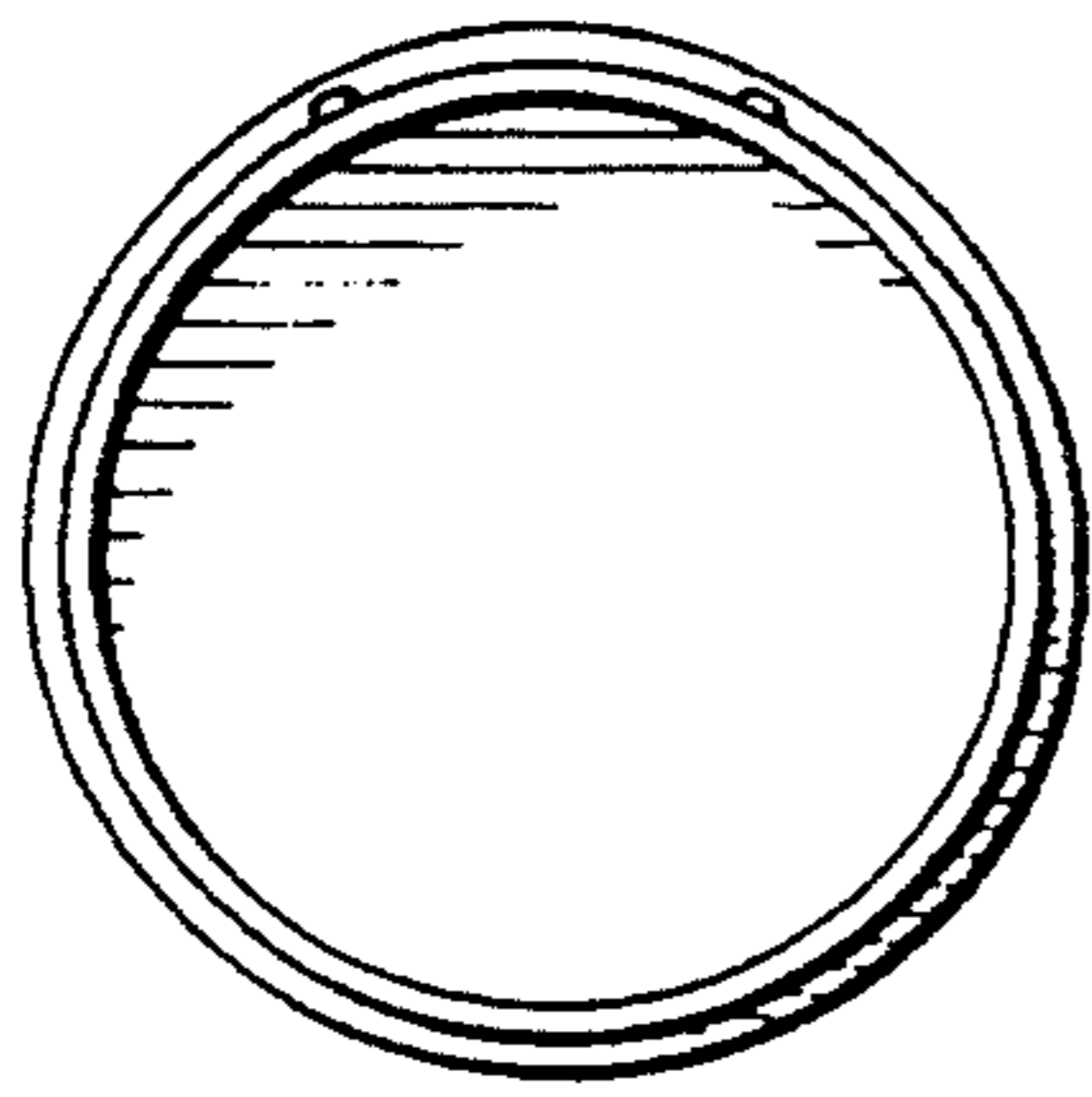

FIG 15

FIG 16

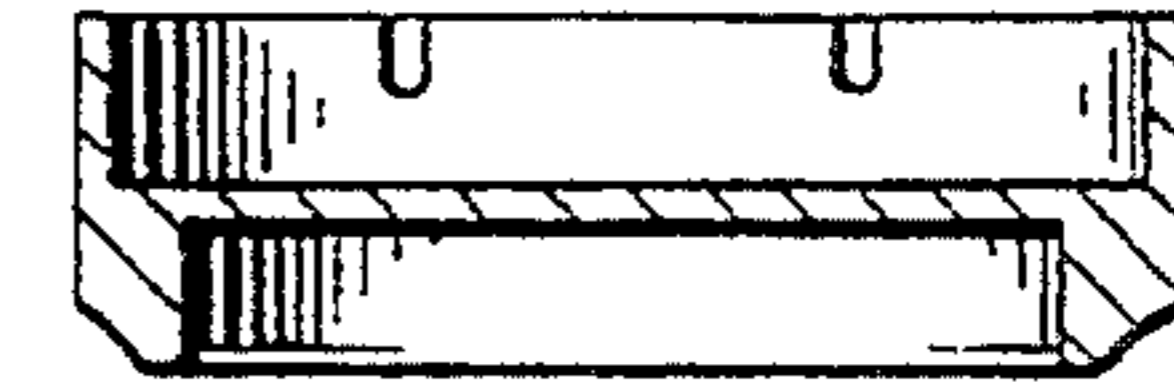
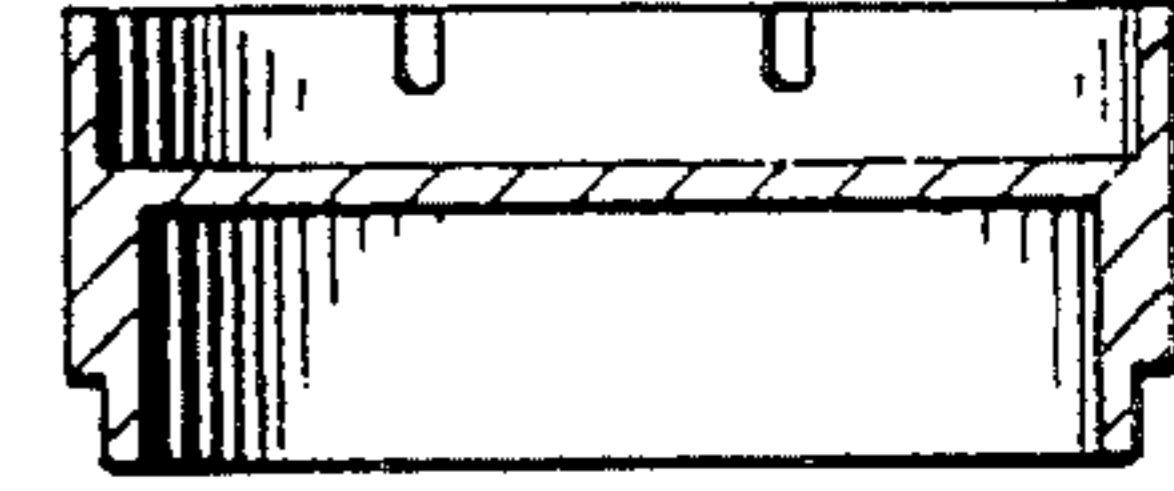
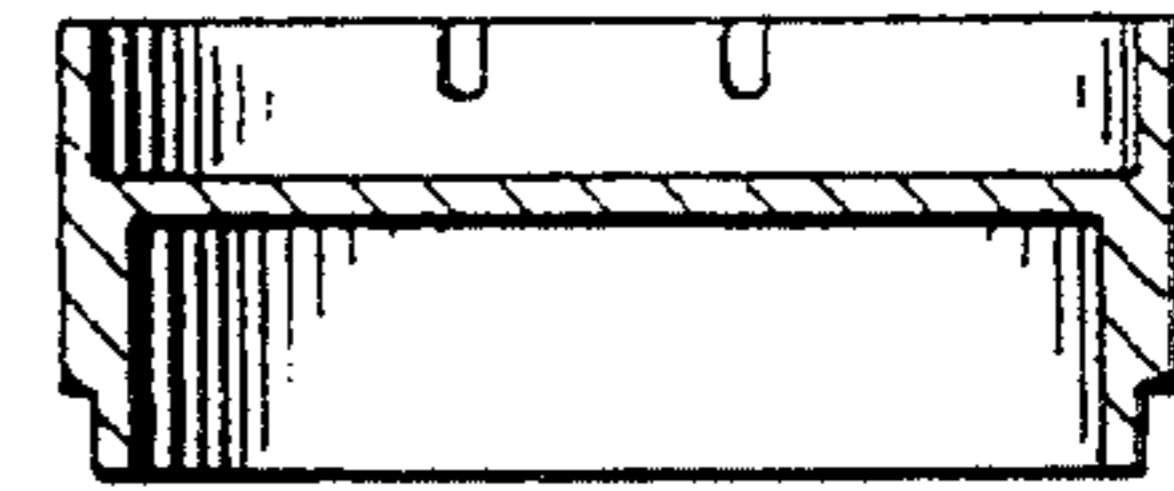
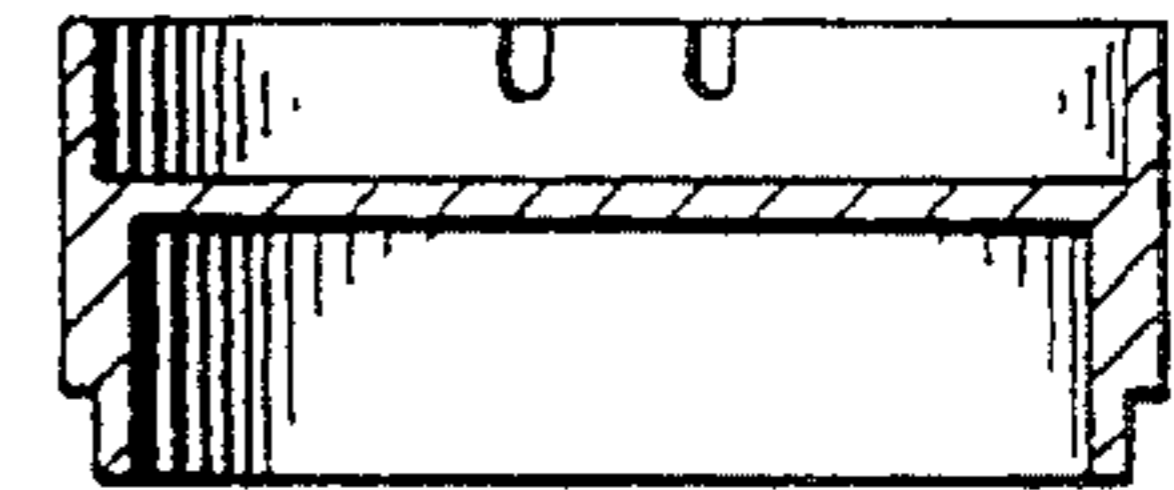
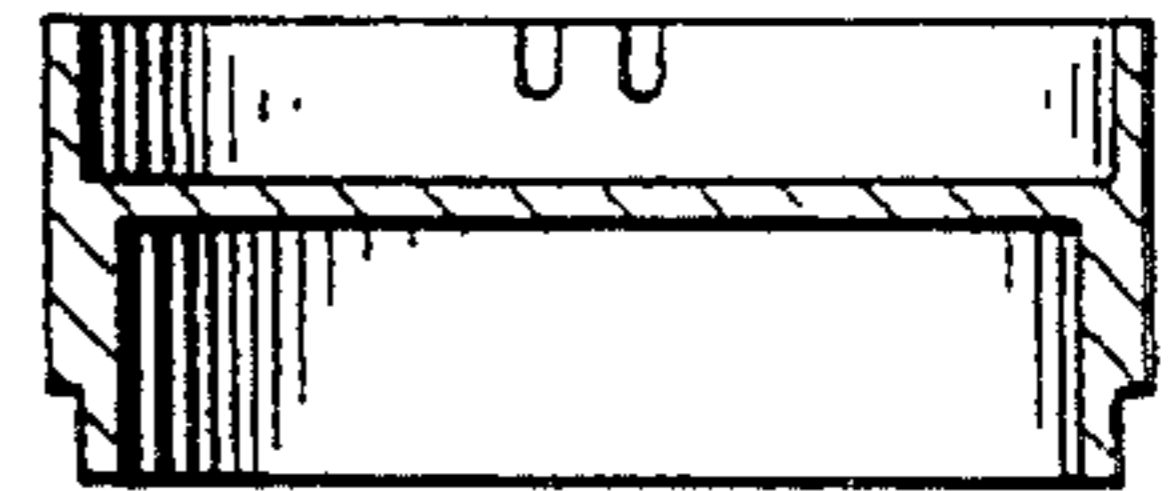
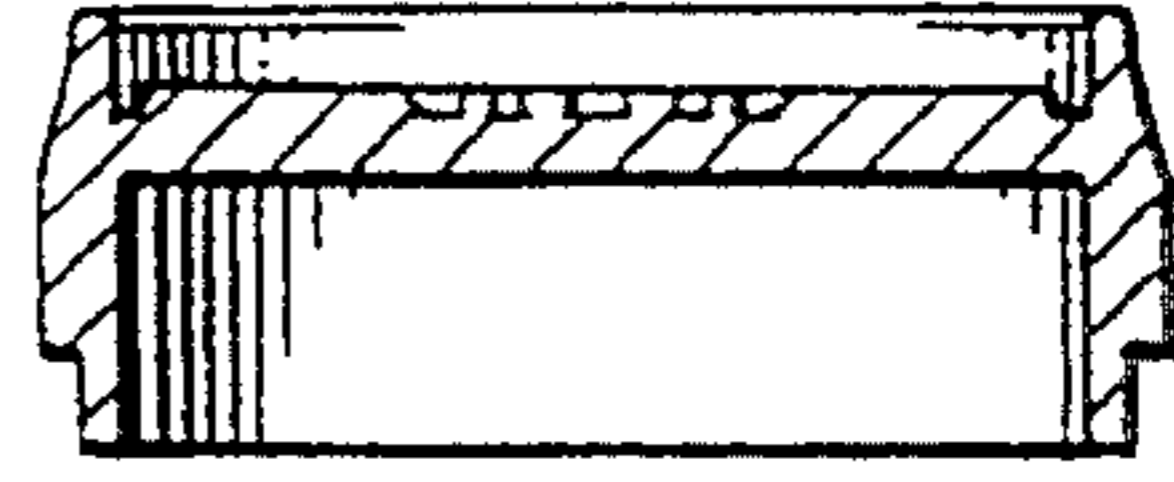
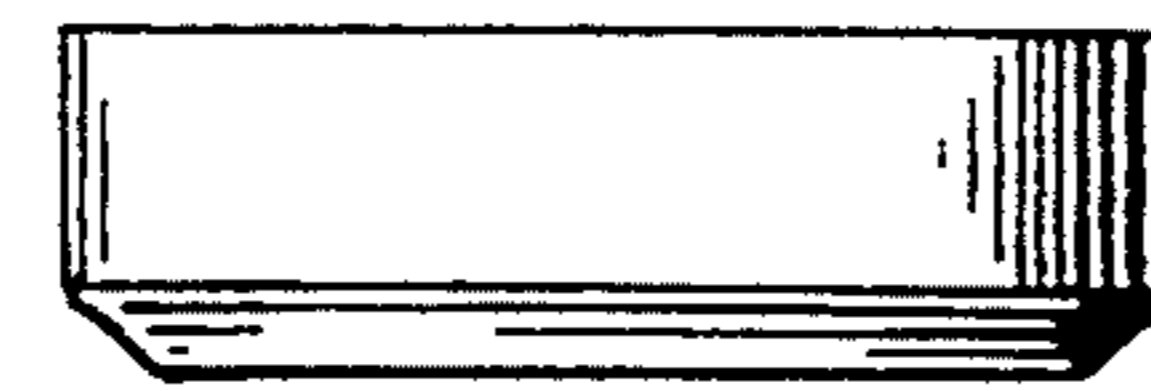
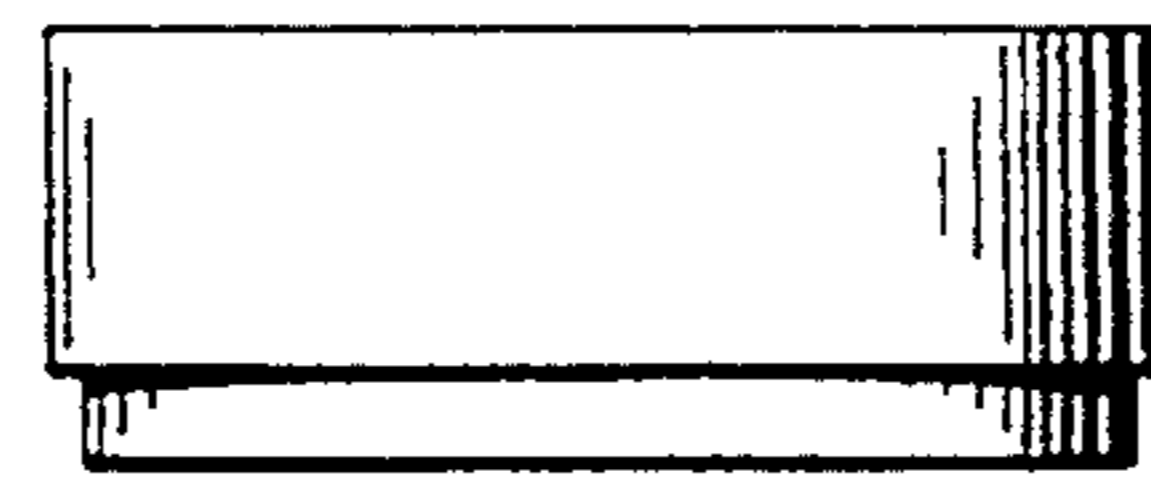
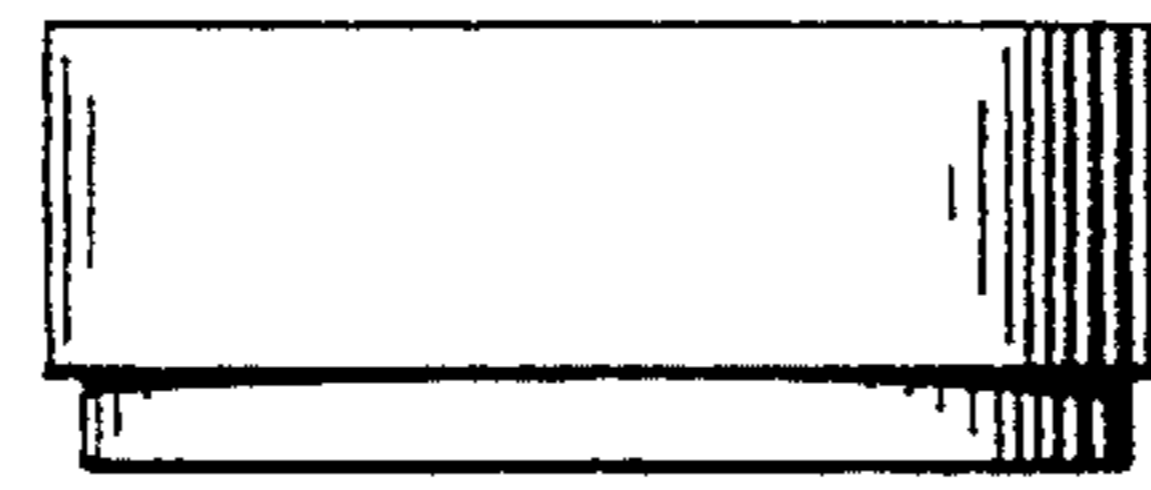
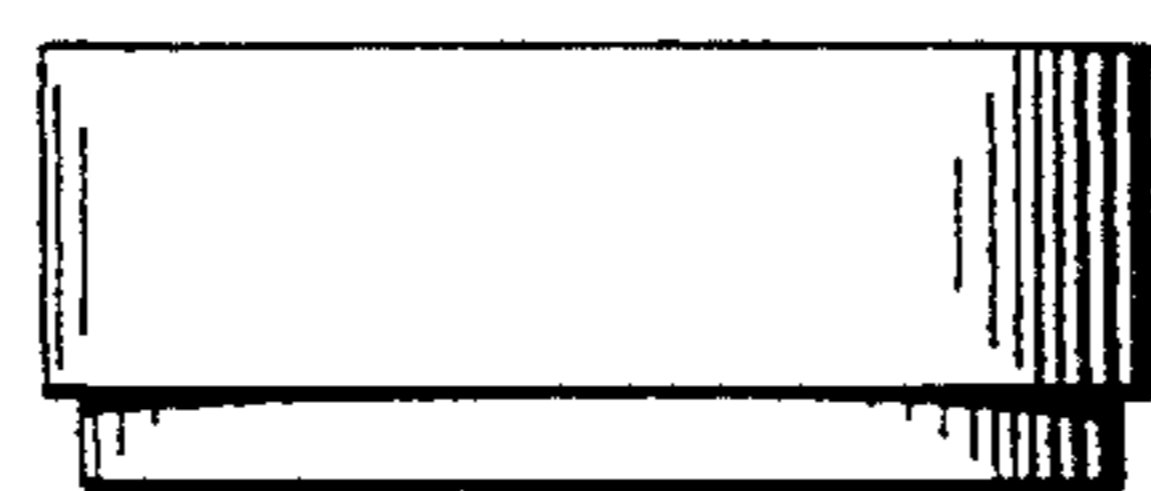
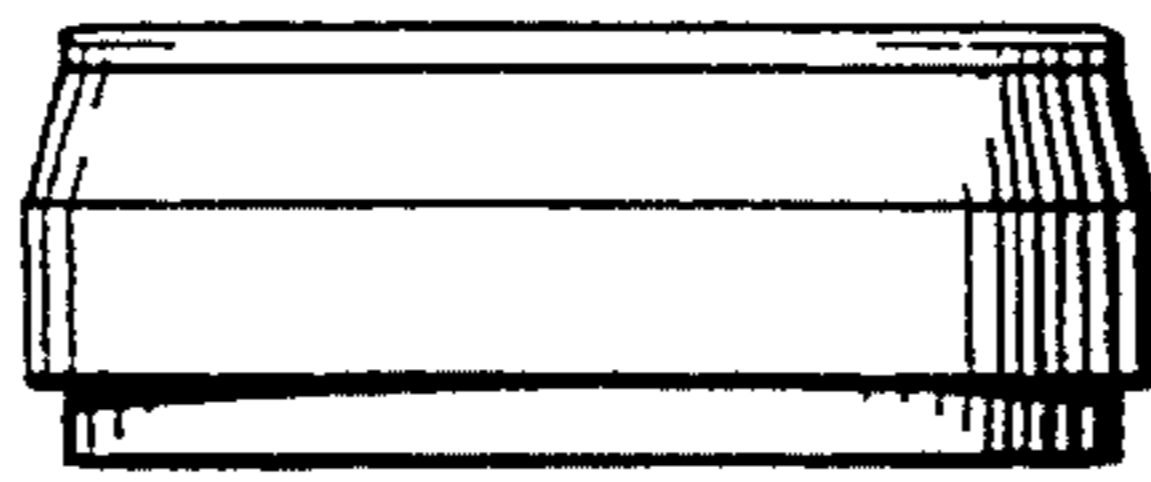
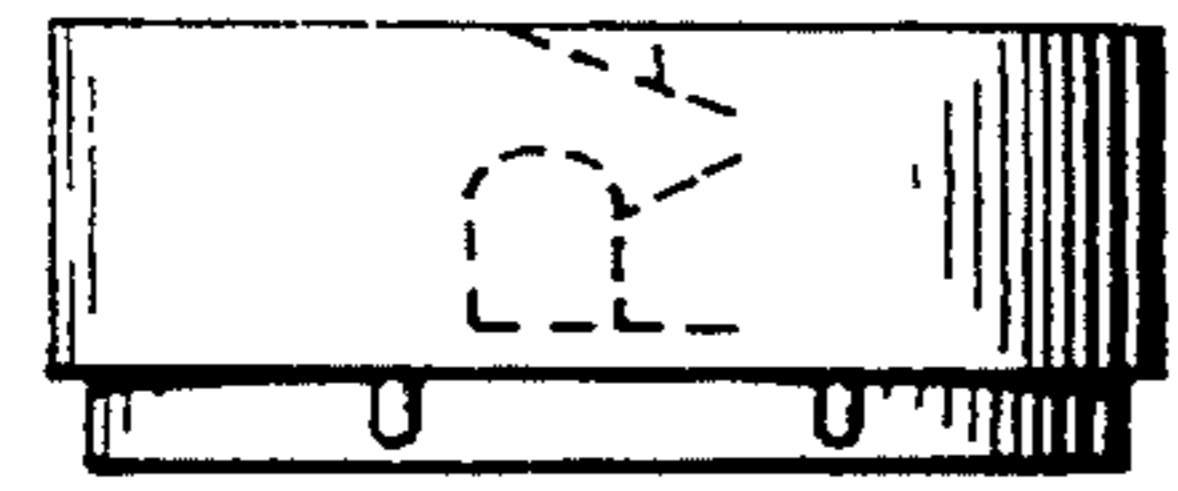
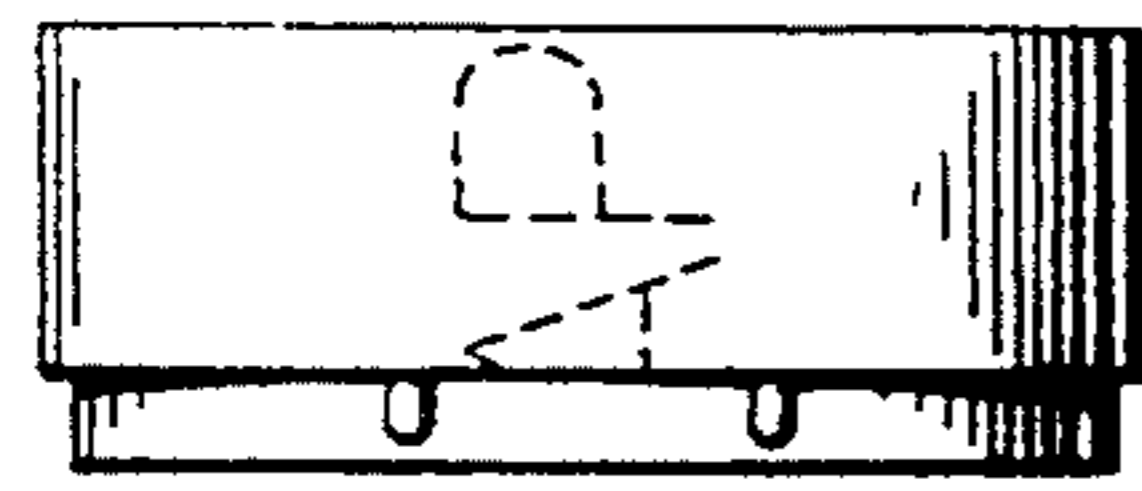
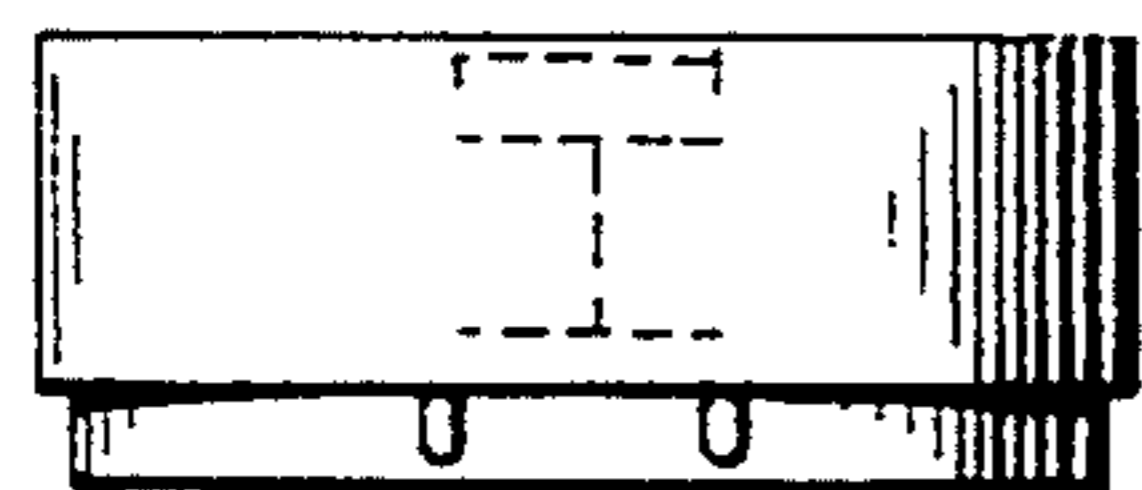
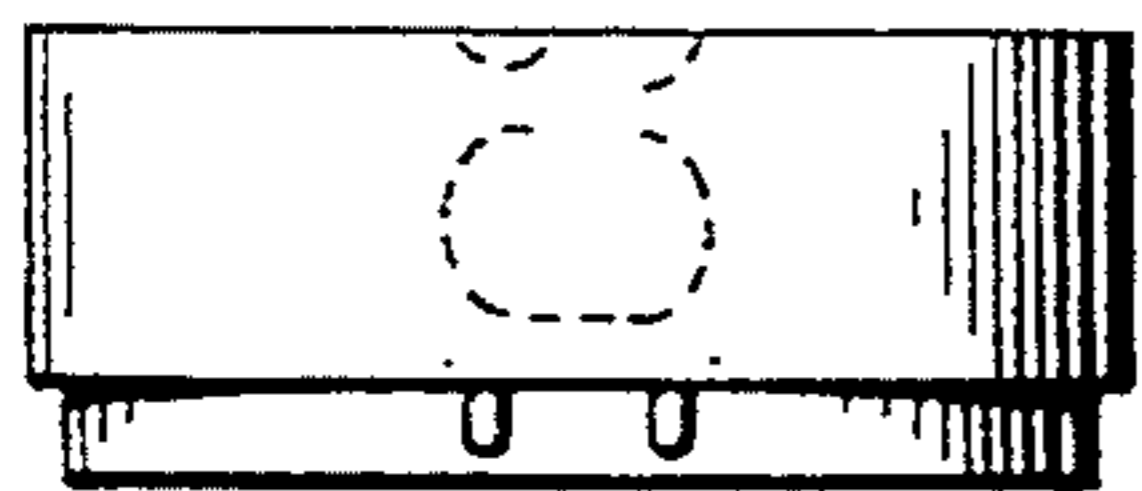
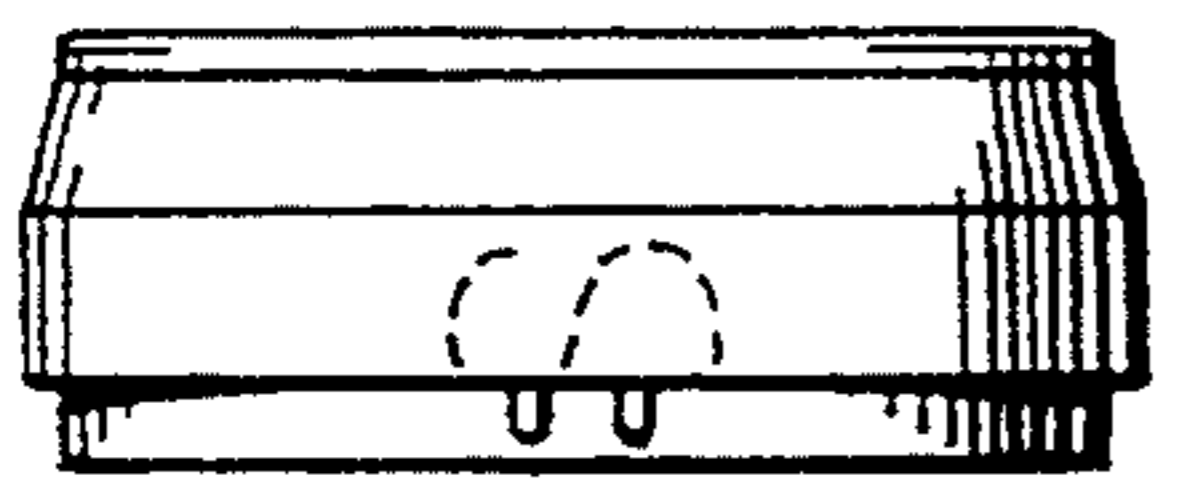

FIG 17

FIG 18

FIG 19