



US00D361319S

# United States Patent [19]

[11] Patent Number: **Des. 361,319**

Orth, Sr. et al.

[45] Date of Patent: **\*\* Aug. 15, 1995**

[54] **VEHICULAR STEP**

2,537,707 1/1951 Russ et al. .... 280/163

[75] Inventors: **Robert J. Orth, Sr.**, Richardson;  
**Kevin W. Wallace**, Wylie, both of  
Tex.

*Primary Examiner*—James M. Gandy  
*Assistant Examiner*—M. Brown  
*Attorney, Agent, or Firm*—Akin, Gump, Strauss, Hauer  
& Feld

[73] Assignee: **Go Industries, Inc.**, Richardson, Tex.

[57] **CLAIM**

[\*\*] Term: **14 Years**

The ornamental design for a vehicular step, as shown  
and described.

[21] Appl. No.: **20,136**

### DESCRIPTION

[22] Filed: **Mar. 21, 1994**

[52] U.S. Cl. .... **D12/203**

[58] Field of Search ..... D12/203; 280/163, 169,  
280/164.1; 182/92, 90; D25/62, 69

FIG. 1 is a perspective view of a vehicular step of our  
new design;  
FIG. 2 is a front elevational view of the vehicular step  
of our new design;  
FIG. 3 is a top plan view thereof;  
FIG. 4 is a rear elevational view thereof;  
FIG. 5 is a bottom plan view thereof;  
FIG. 6 is a side elevational view taken along the lines  
6—6 of FIG. 2; and,  
FIG. 7 is a side elevational view taken along the lines  
7—7 of FIG. 2.

[56] **References Cited**

#### U.S. PATENT DOCUMENTS

D. 290,833	7/1987	Walters	.....	D12/203
D. 297,135	8/1988	Davenport	.....	D12/203
D. 297,230	8/1988	Huff	.....	D12/203
D. 340,905	11/1993	Orth, Sr. et al.	.....	D12/203

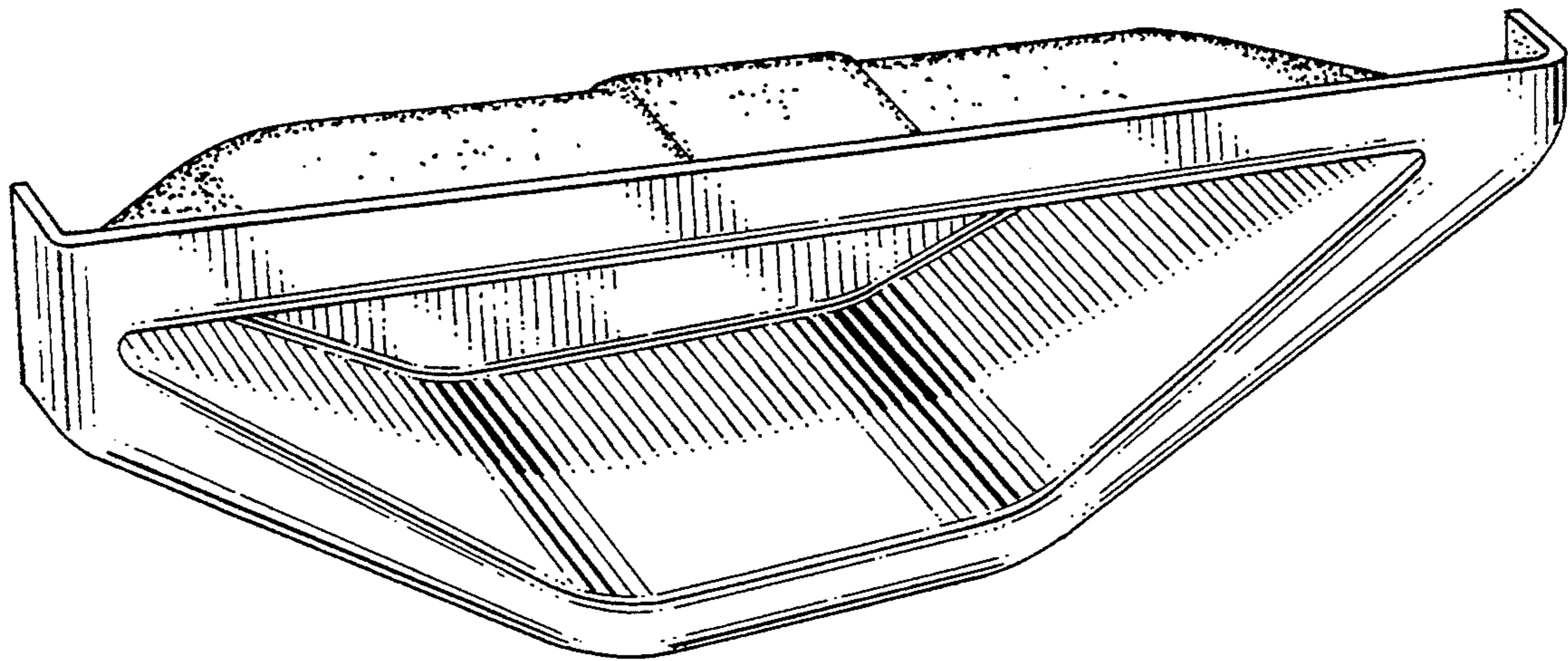

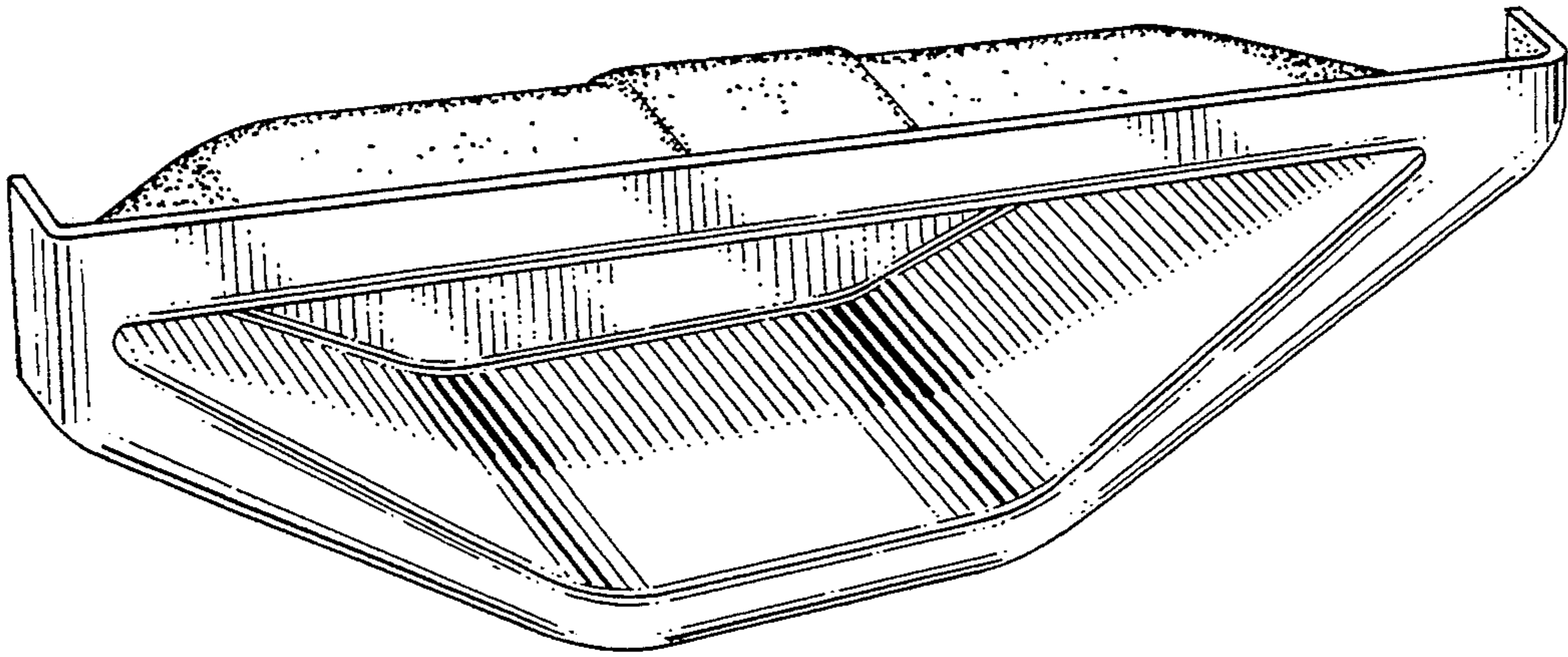

FIG. 1

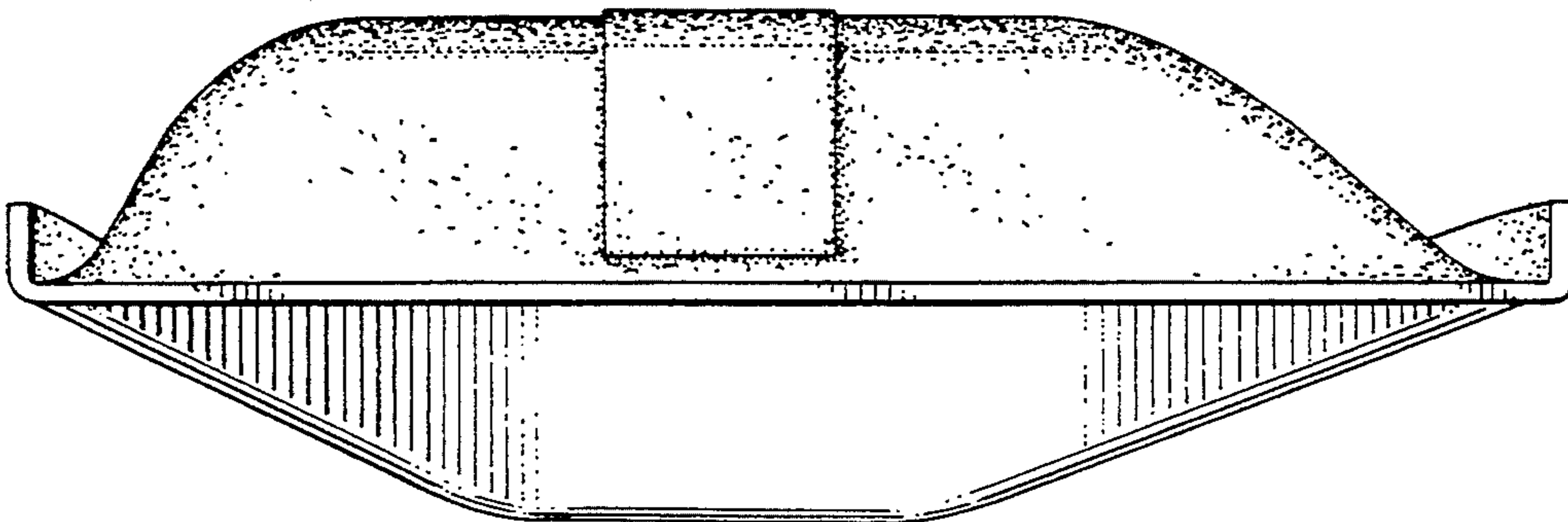
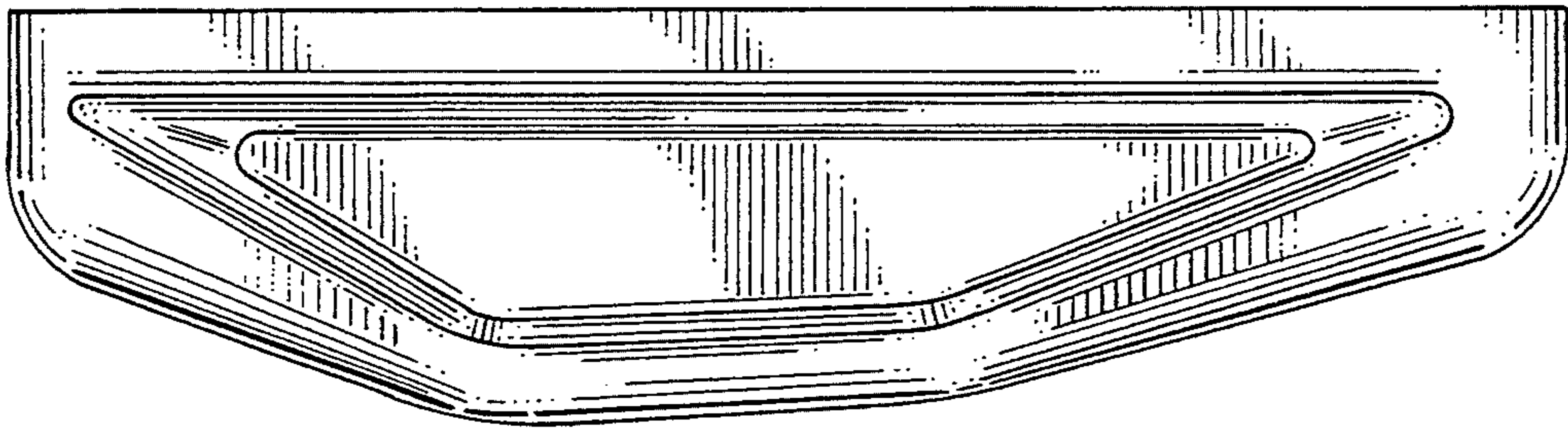

FIG. 3

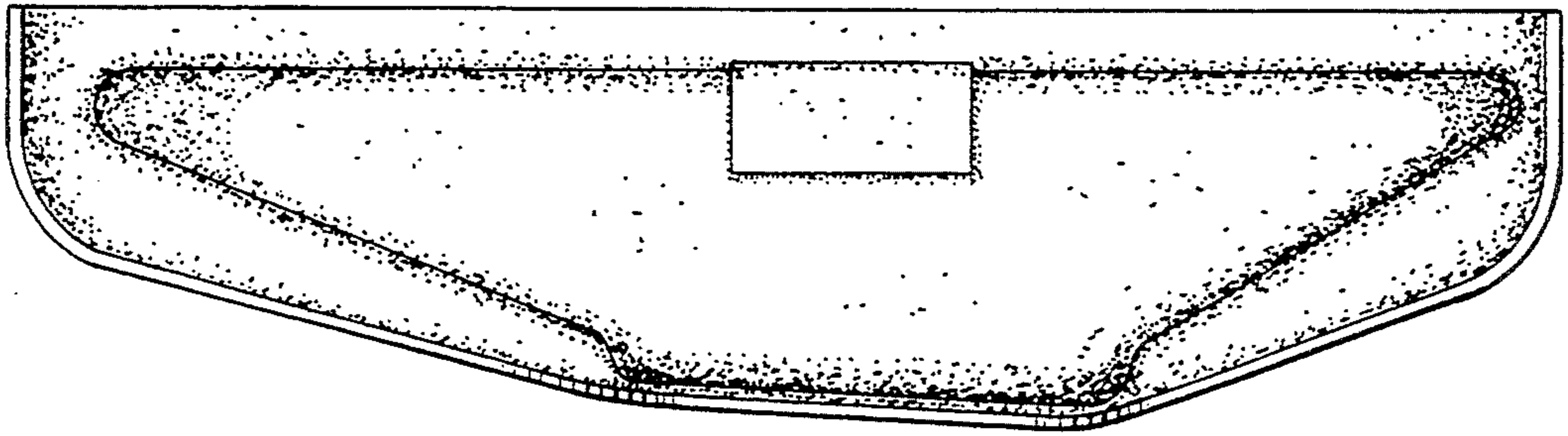

FIG. 4

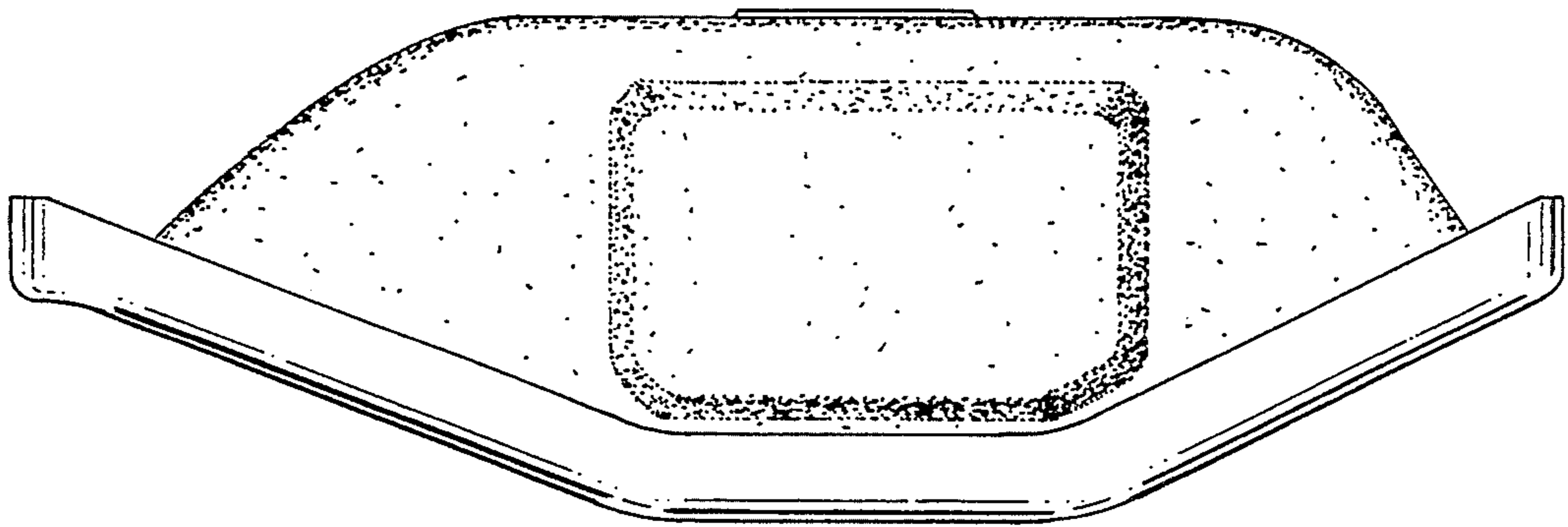

FIG. 5

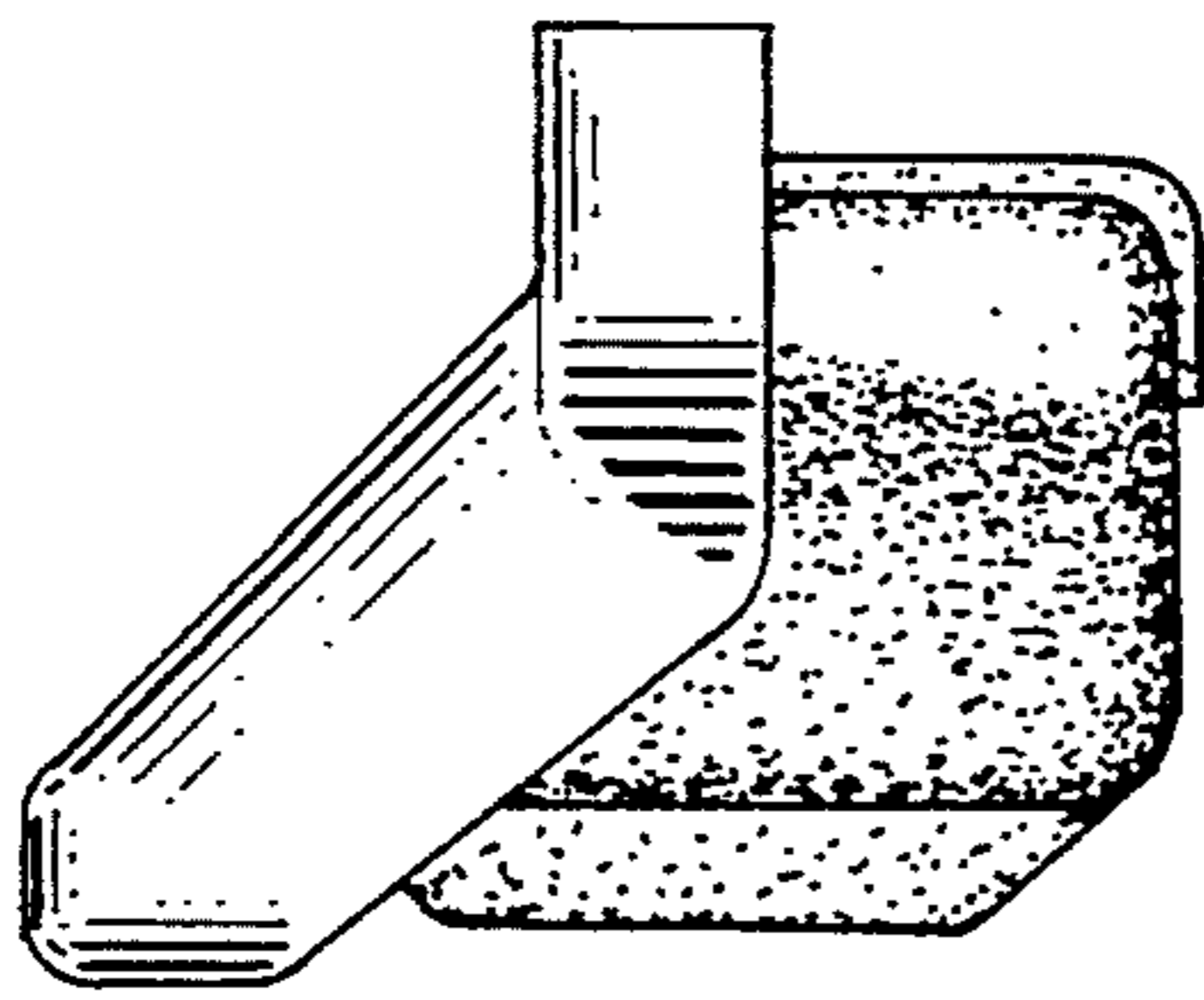

FIG. 6

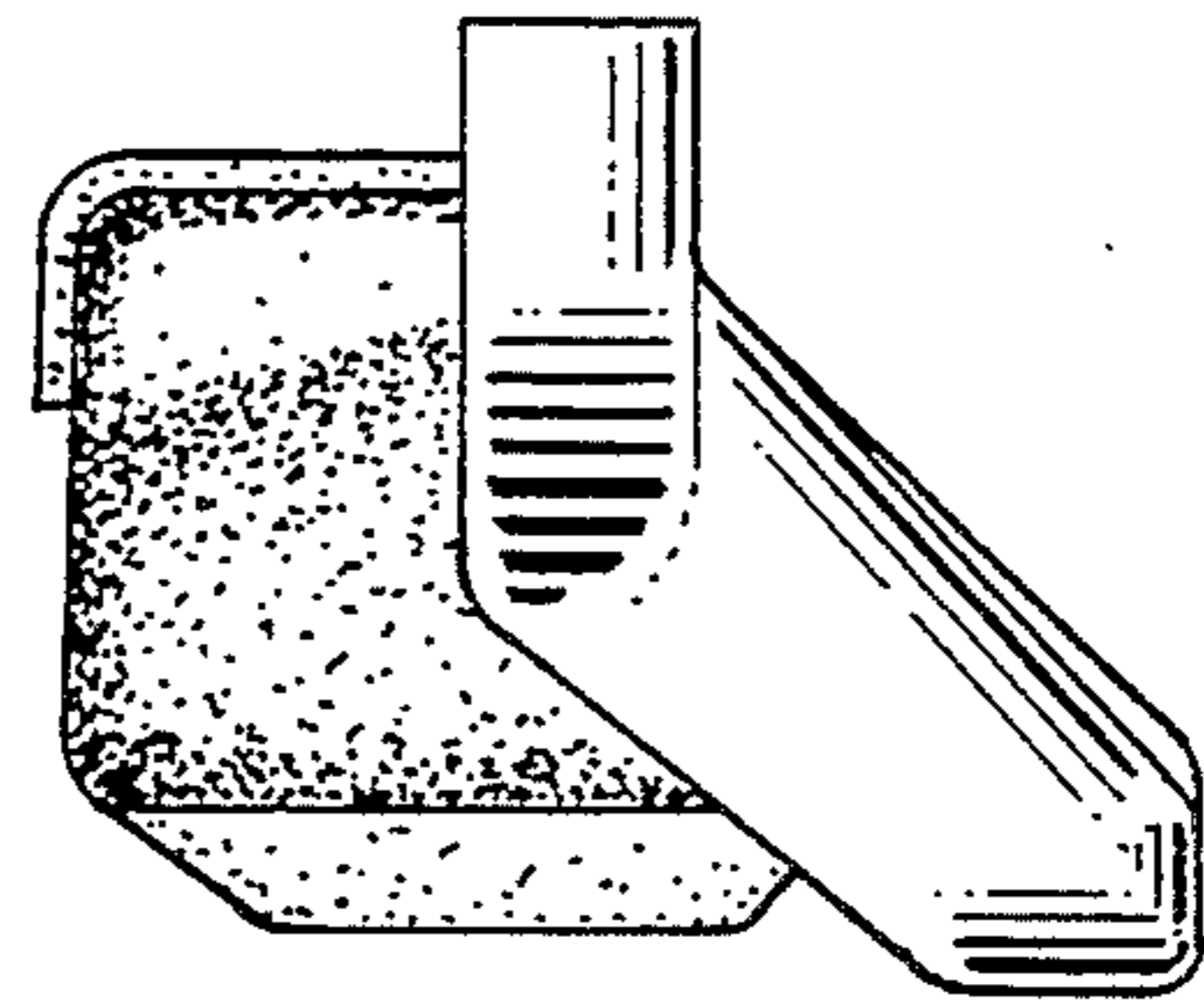

FIG. 7