



US00D361260S

# United States Patent [19]

[11] Patent Number: **Des. 361,260**

Trentham

[45] Date of Patent: **\*\* Aug. 15, 1995**

[54] PICTURE HANGER UNIT

[76] Inventor: **Robert L. Trentham**, HC 77 Box 133,  
Licking, Mo. 65542

[\*\*] Term: **14 Years**

[21] Appl. No.: **20,526**

[22] Filed: **Mar. 28, 1994**

[52] U.S. Cl. .... **D8/373**

[58] Field of Search ..... **D8/354, 366, 367, 371,  
D8/373; D6/300, 302; 248/475.1, 492, 489,  
493, 300, 309.1, 301, 304, 215; 211/87**

4,530,482 7/1985 Berinson .  
4,610,419 9/1986 Swanson .  
4,645,165 2/1987 Raap .  
4,883,247 11/1989 Crandall .  
5,069,411 12/1991 Murphy .  
5,103,573 4/1992 Ehling et al. .

*Primary Examiner*—A. Hugo Word  
*Assistant Examiner*—Holly H. Baynham  
*Attorney, Agent, or Firm*—Kalish & Gilster

## [57] CLAIM

The ornamental design for a picture hanger unit, as described and shown.

## DESCRIPTION

FIG. 1 is a rear, exploded perspective view of a picture hanger unit showing my new design;  
FIG. 2 is a top plan view thereof;  
FIG. 3 is a bottom plan view thereof;  
FIG. 4 is a side elevational view in the fully assembled position with the opposite side being a mirror image and with the broken line showing of structure being for illustrative purposes only and forms no part of the claimed design;  
FIG. 5 is a rear elevational view fully assembled; and,  
FIG. 6 is a front elevational view fully assembled.

## [56] References Cited

### U.S. PATENT DOCUMENTS

3,146,981 9/1964 Wheeler .  
3,265,339 8/1966 Hushek .  
3,912,216 10/1975 Gano .  
3,982,719 9/1976 Kilborne .  
4,040,593 8/1977 Wiley .  
4,083,525 4/1978 Rath .  
4,171,117 10/1979 Prochaska .  
4,241,510 12/1980 Radecki .  
4,463,924 8/1984 Conti .  
4,496,128 1/1985 Larsen .

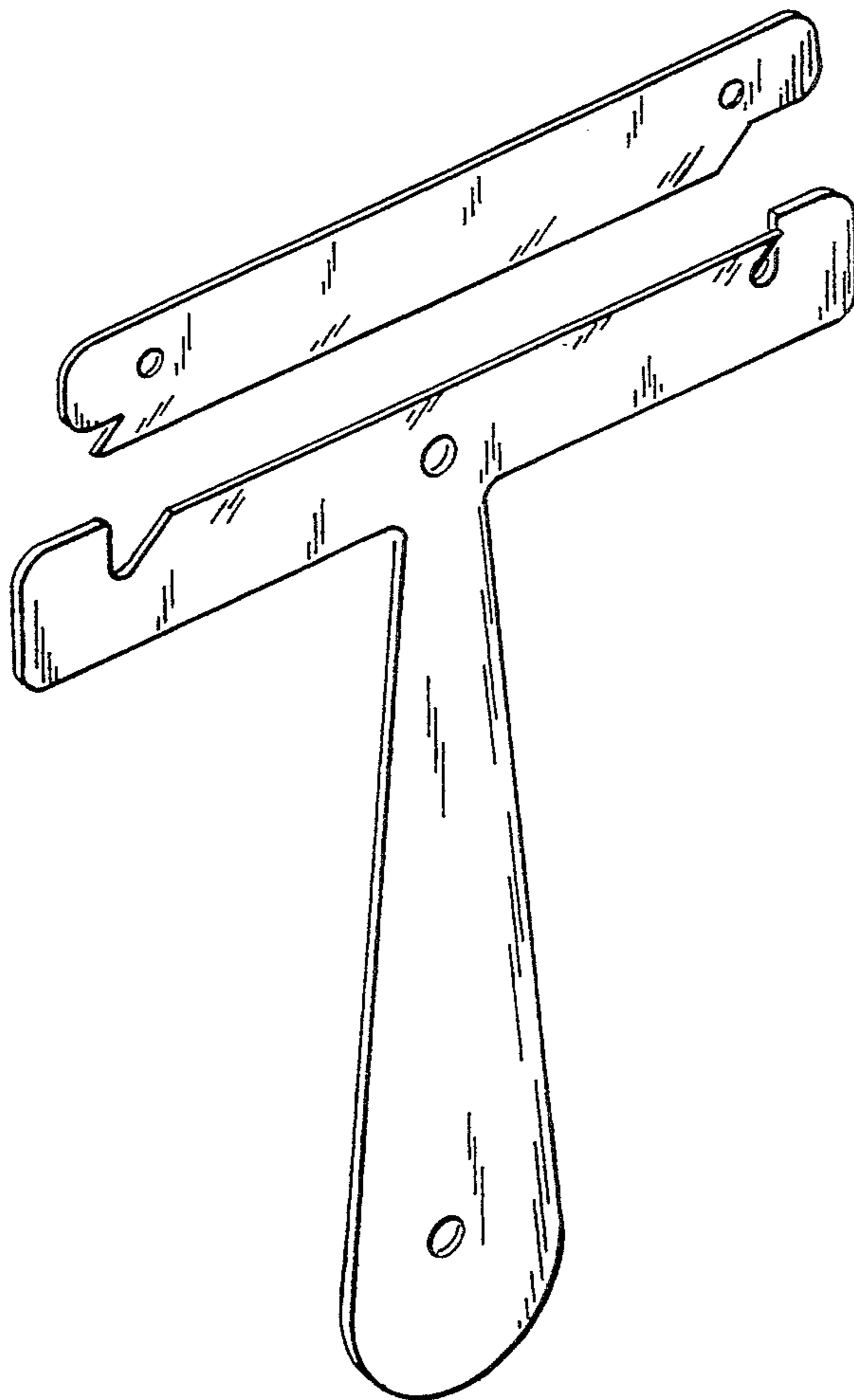

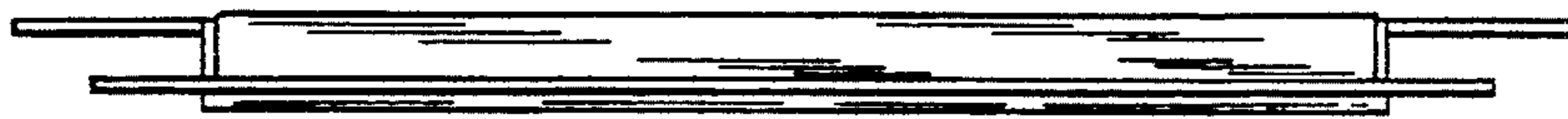
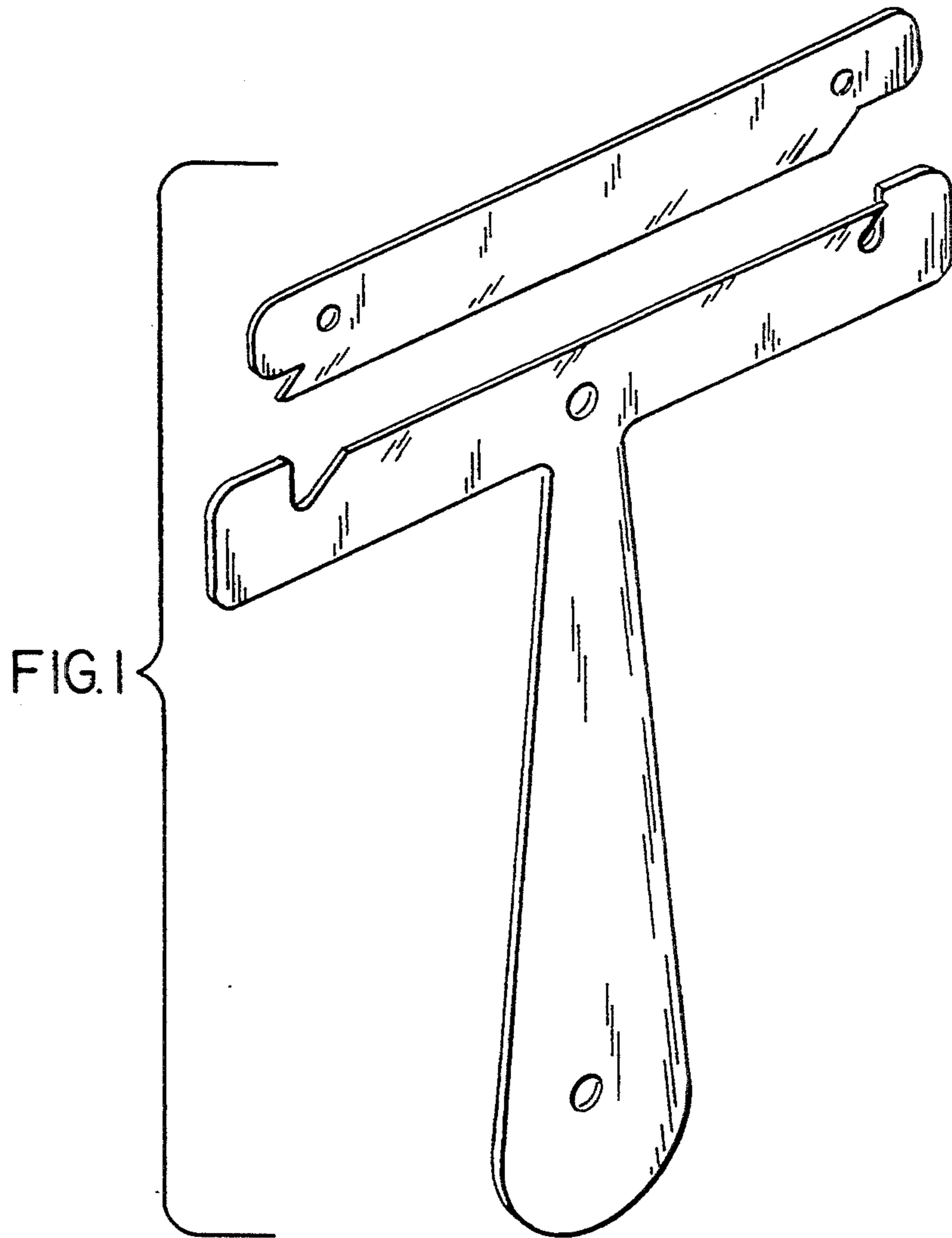

FIG. 2

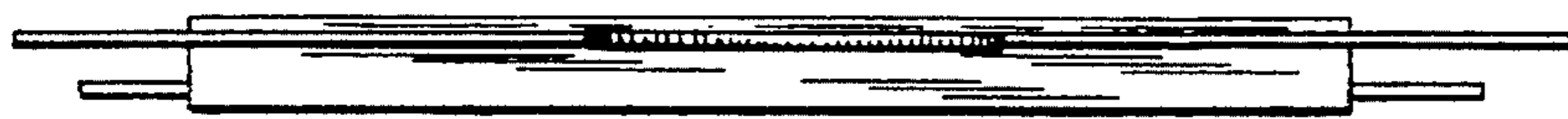

FIG. 3

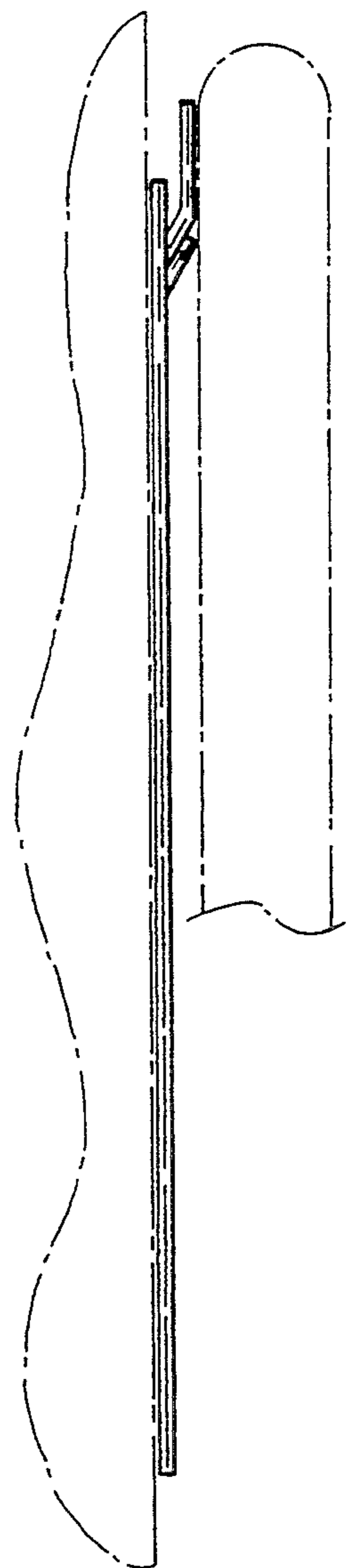

FIG. 4

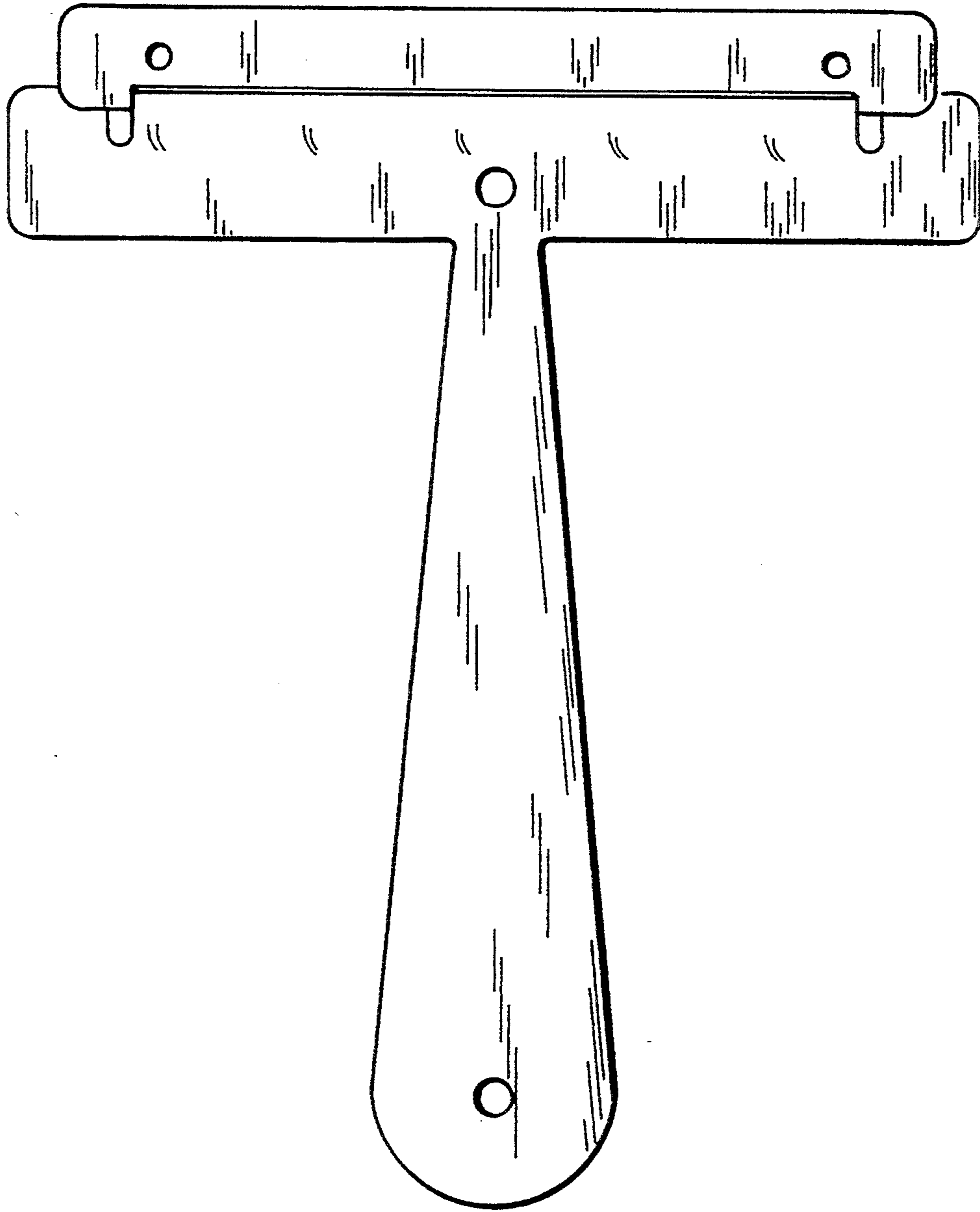

FIG. 5

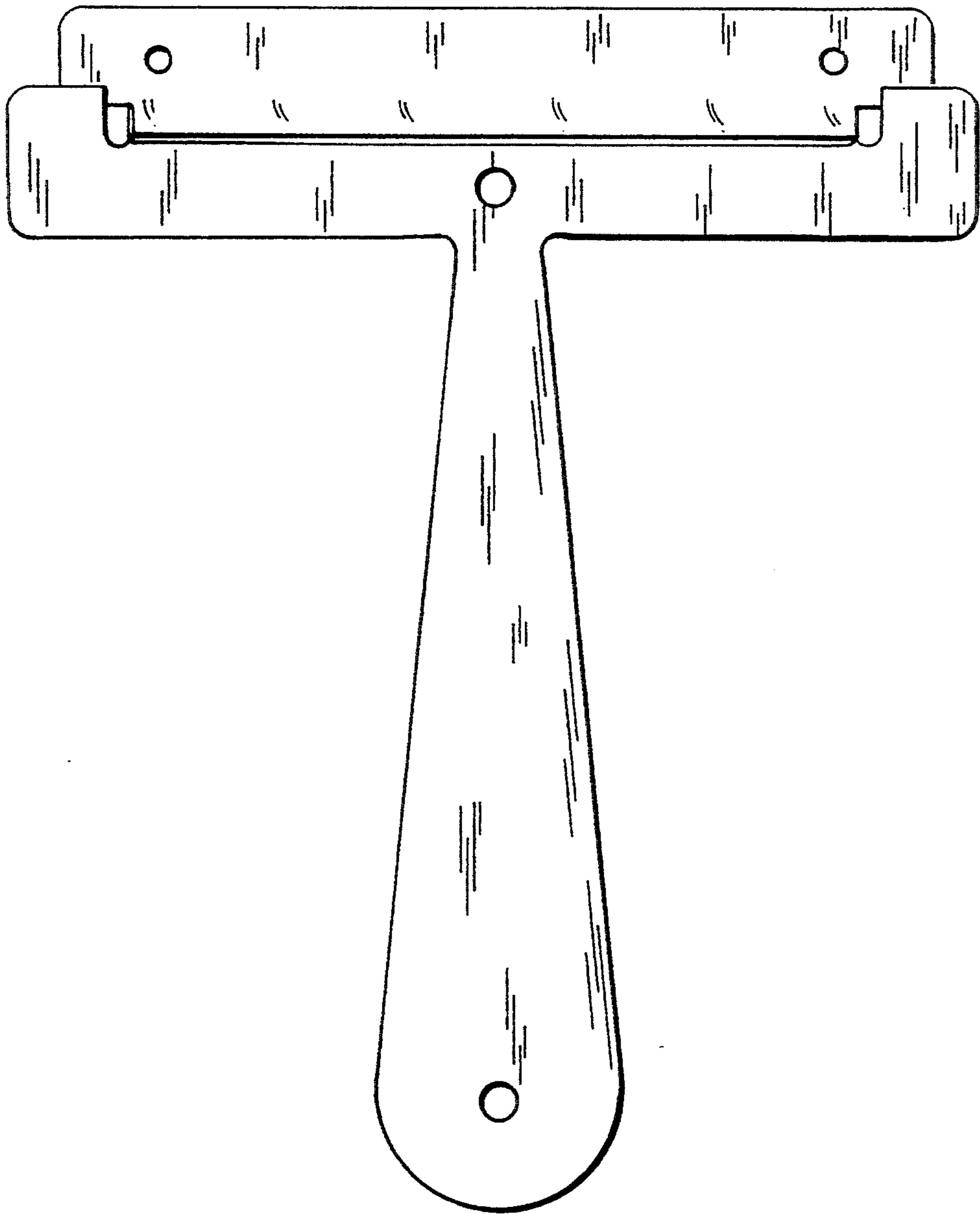

FIG. 6