



US00D361250S

United States Patent [19]

Heinrich

[11] Patent Number: **Des. 361,250**

[45] Date of Patent: **** Aug. 15, 1995**

[54] **STEERING CLUTCH LIFTING BRACKET**

[76] Inventor: **Dan A. Heinrich**, 2931 Shelley Dr., Grand Junction, Colo. 81503

[**] Term: **14 Years**

[21] Appl. No.: **16,644**

[22] Filed: **Dec. 21, 1993**

[52] U.S. Cl. **D8/54; D34/35**

[58] Field of Search **D34/28, 35; D8/14, 54, D8/56; 29/278, 279, 280, 234; 294/94, 95, 100, 115; 269/48.1**

2,648,126	8/1953	Flickinger	29/278
3,019,521	2/1962	Clark	29/278
3,475,793	11/1969	Oetiker .	
4,150,591	4/1979	Ackeret .	
4,583,275	4/1986	Diaz .	
4,697,482	10/1987	Hutton .	
5,083,642	1/1992	Stefanutti et al. .	

Primary Examiner—Brian N. Vinson
Assistant Examiner—Robin V. Taylor

[57] **CLAIM**

The ornamental design for the steering clutch lifting bracket, as shown and described.

DESCRIPTION

FIG. 1 is a front elevational view of the steering clutch lifting bracket showing my new design; FIG. 2 is a rear elevational view thereof; FIG. 3 is a left side elevational view thereof; FIG. 4 is a right side elevational view thereof; FIG. 5 is a top plan view thereof; FIG. 6 is a bottom plan view thereof; and, FIG. 7 is a perspective view thereof.

[56] **References Cited**

U.S. PATENT DOCUMENTS

D. 157,057	1/1950	Lane	D8/54
259,172	6/1882	Kirkwood	29/278
1,421,987	7/1922	Quinn	29/278
1,422,185	7/1922	Dalitz	29/278
1,576,060	3/1926	Moss	29/278
1,641,895	9/1927	Merdian	29/280
2,356,881	8/1944	Pollock	29/278

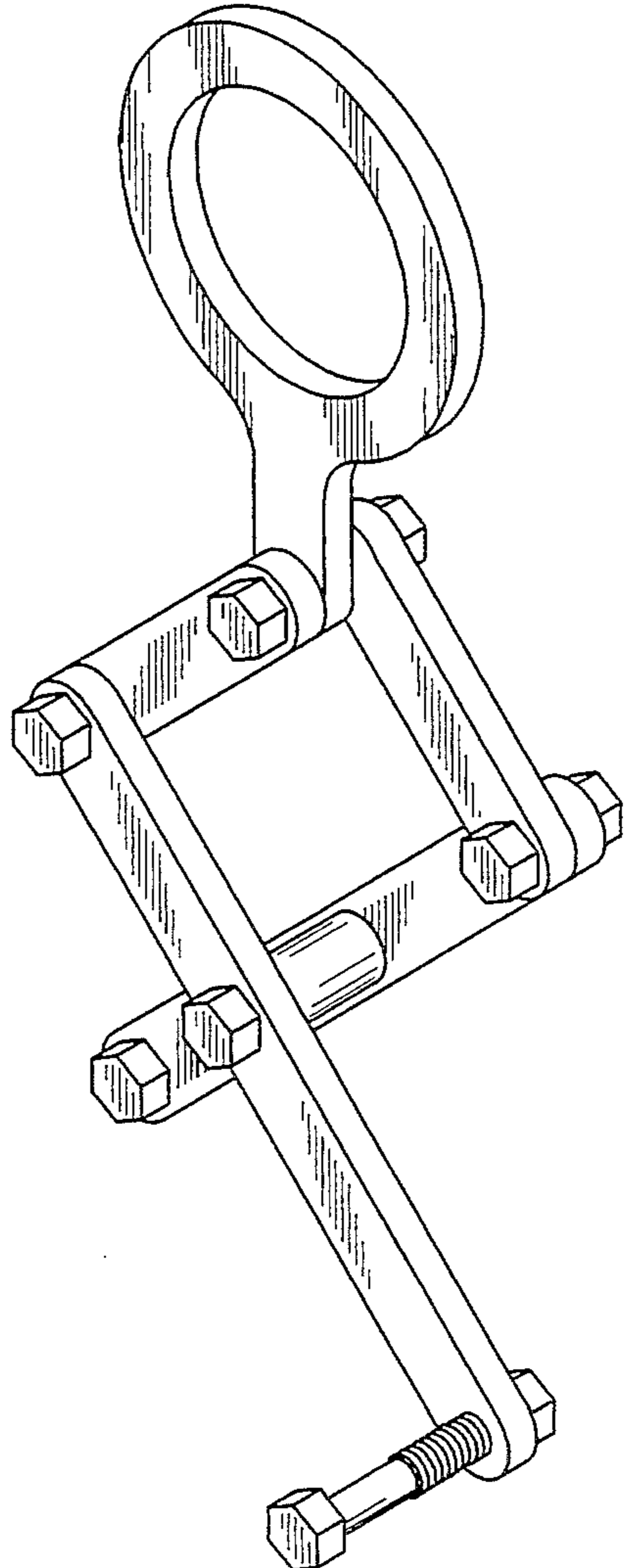
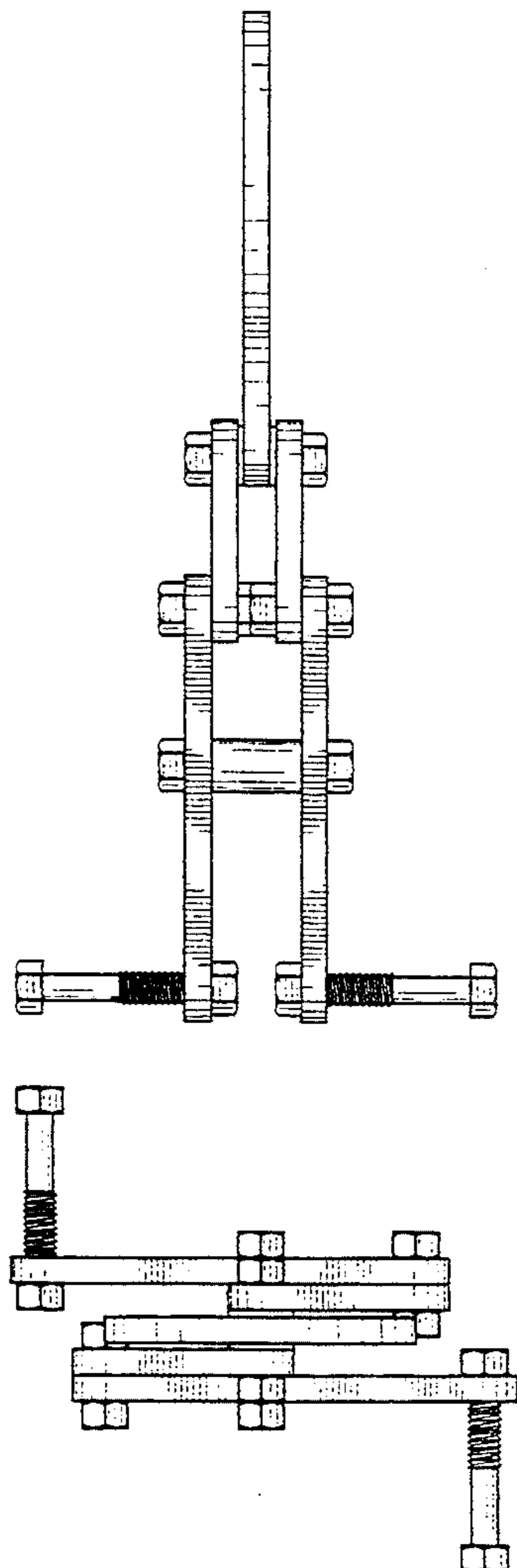

FIG. 1

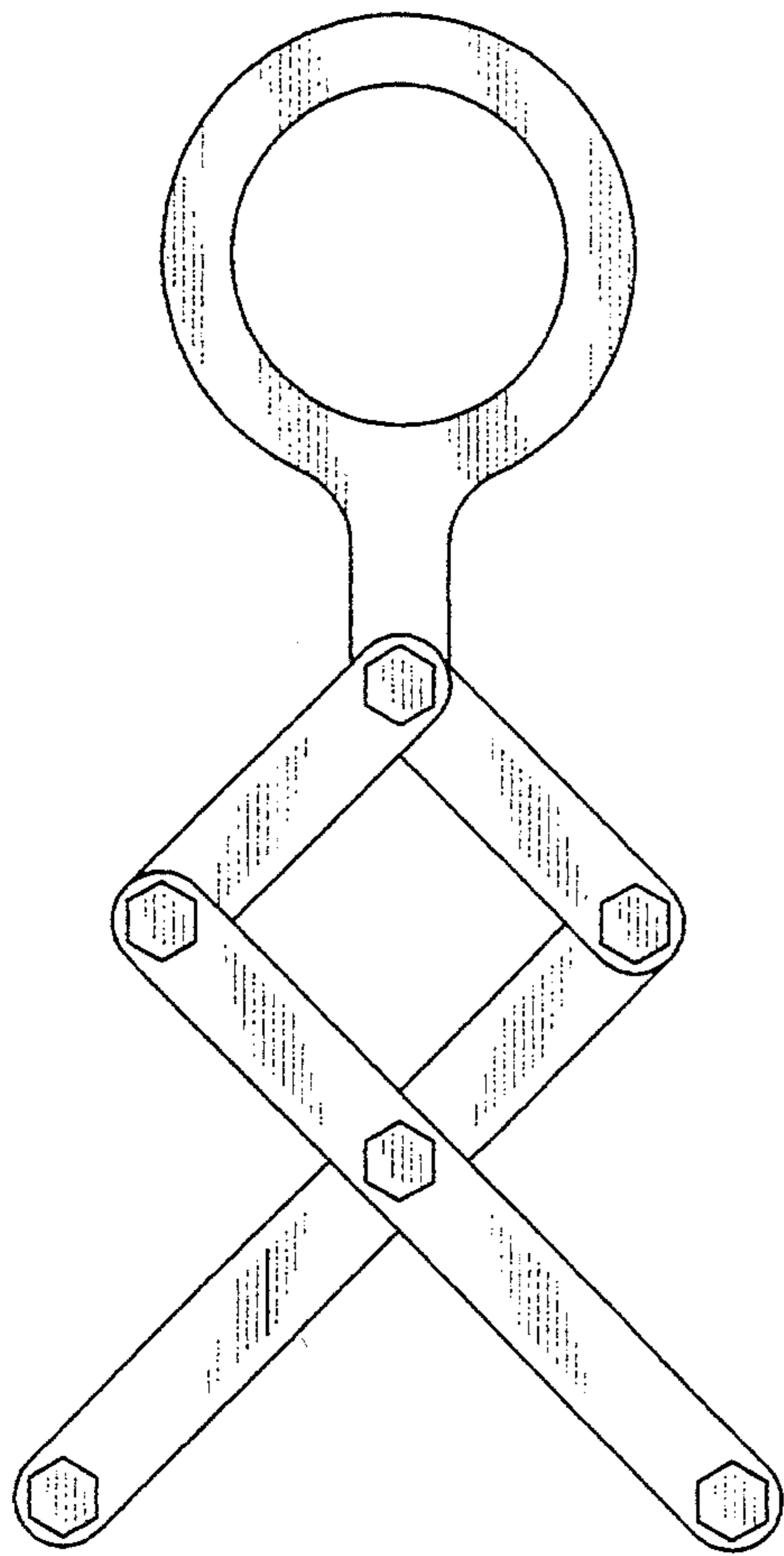

FIG. 2

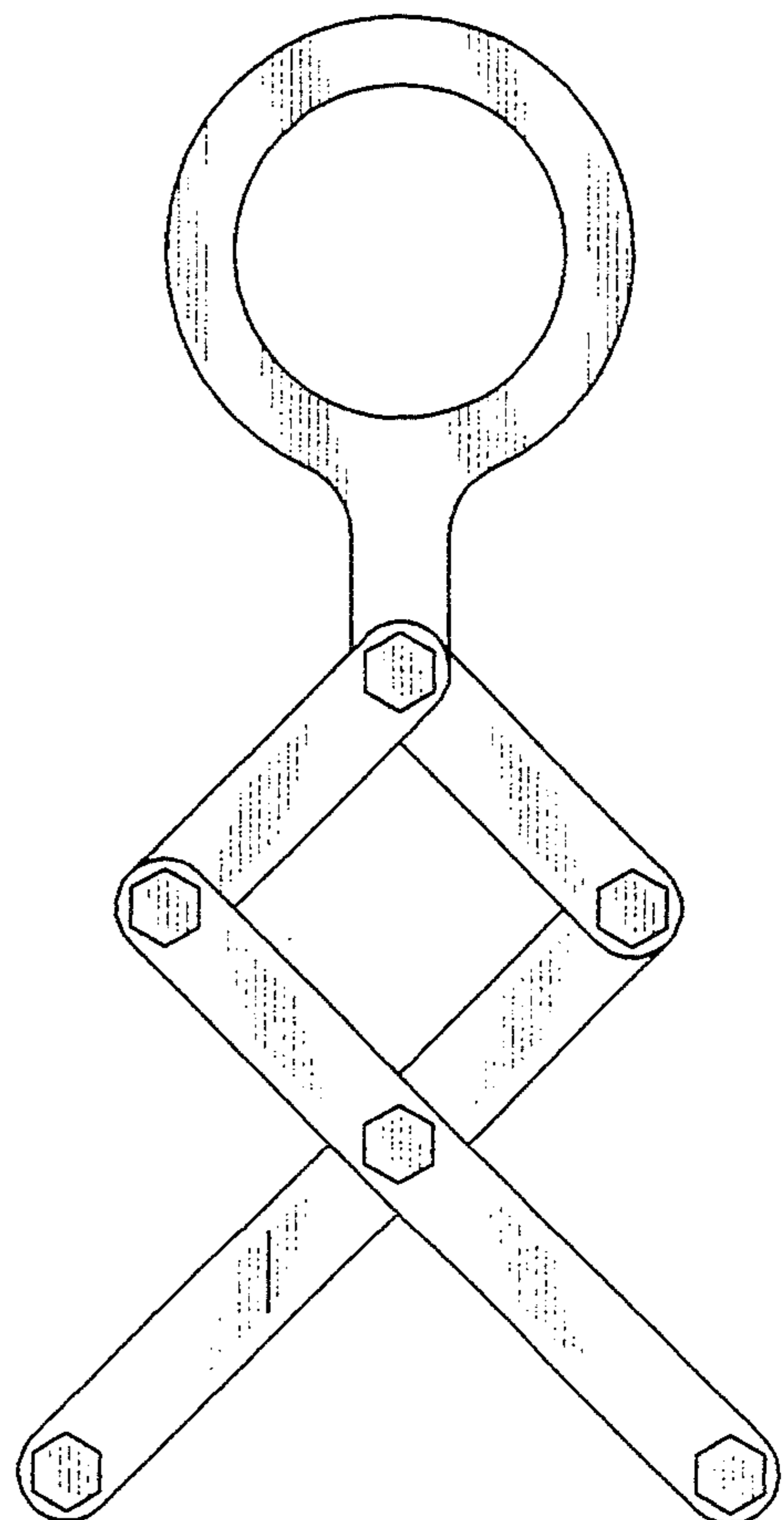

FIG. 3

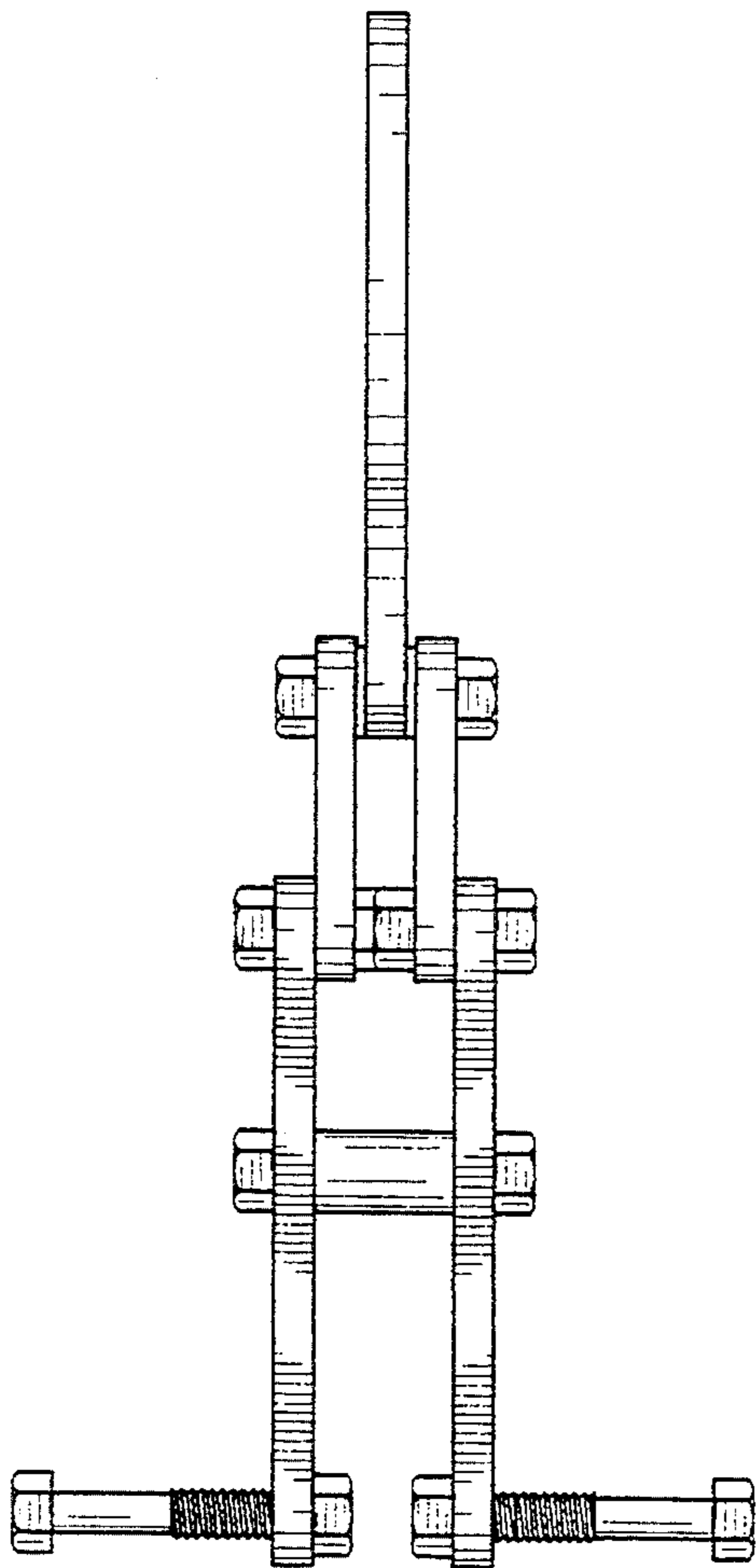

FIG. 4

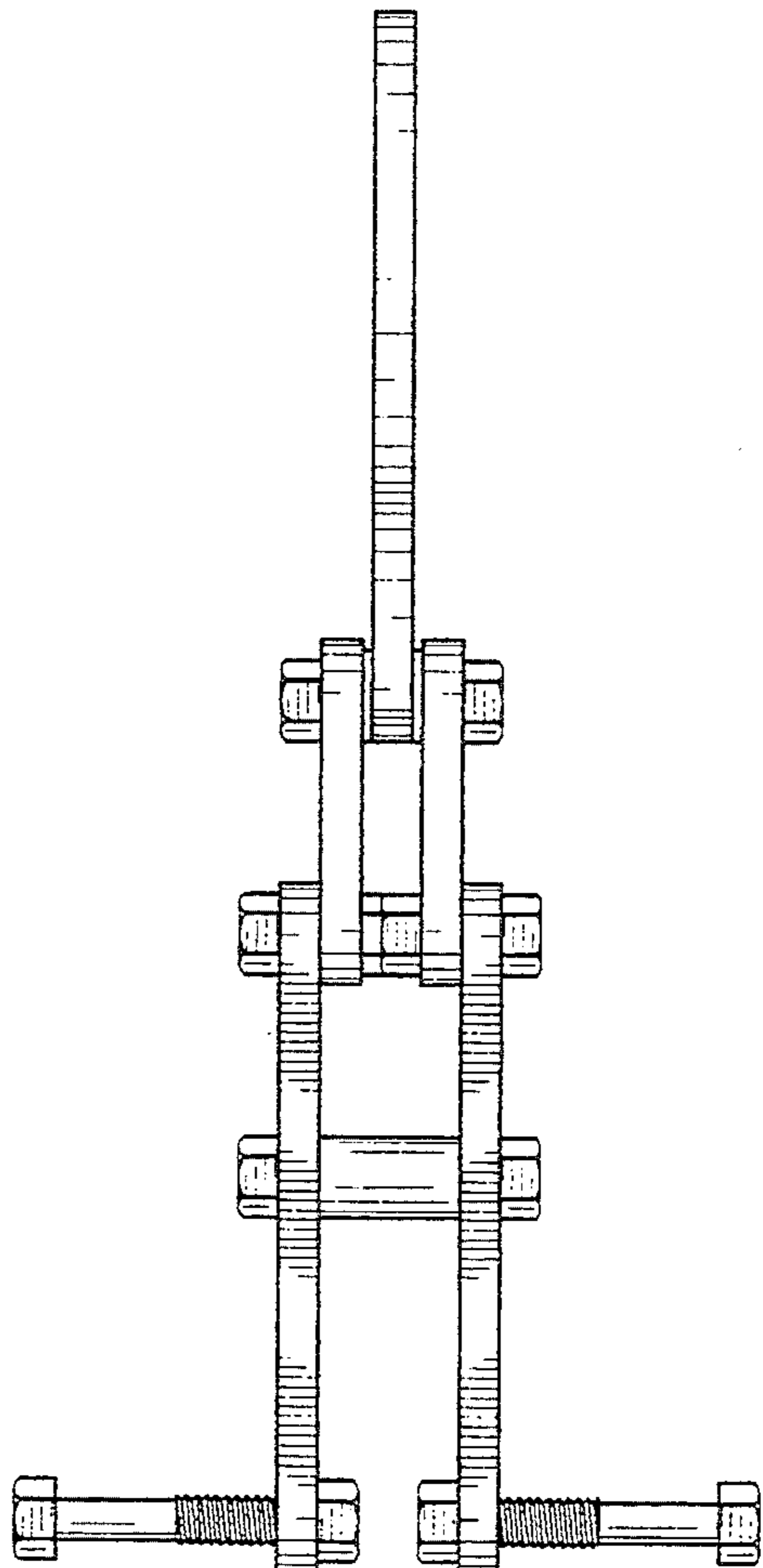

FIG. 5

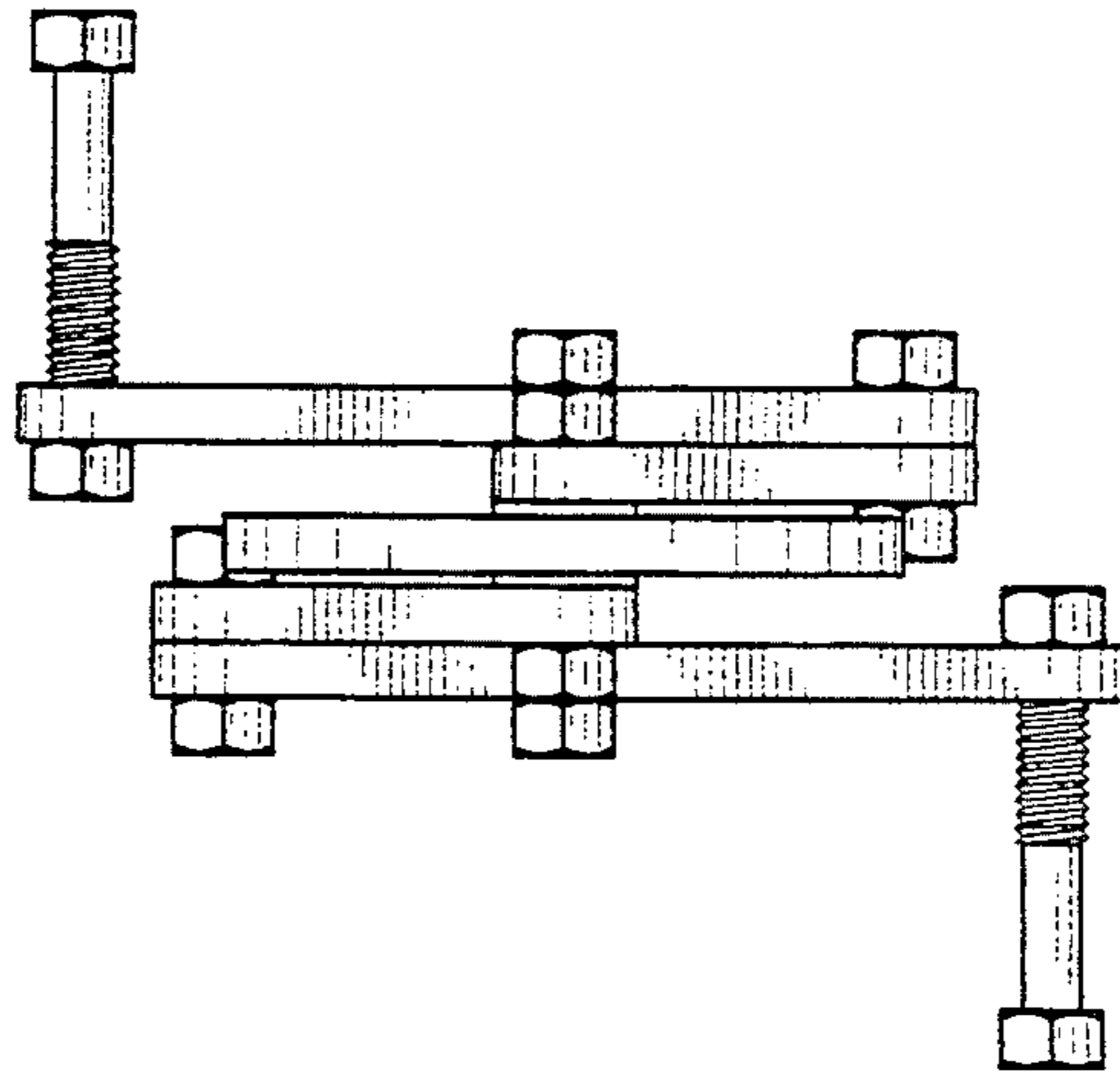

FIG. 6

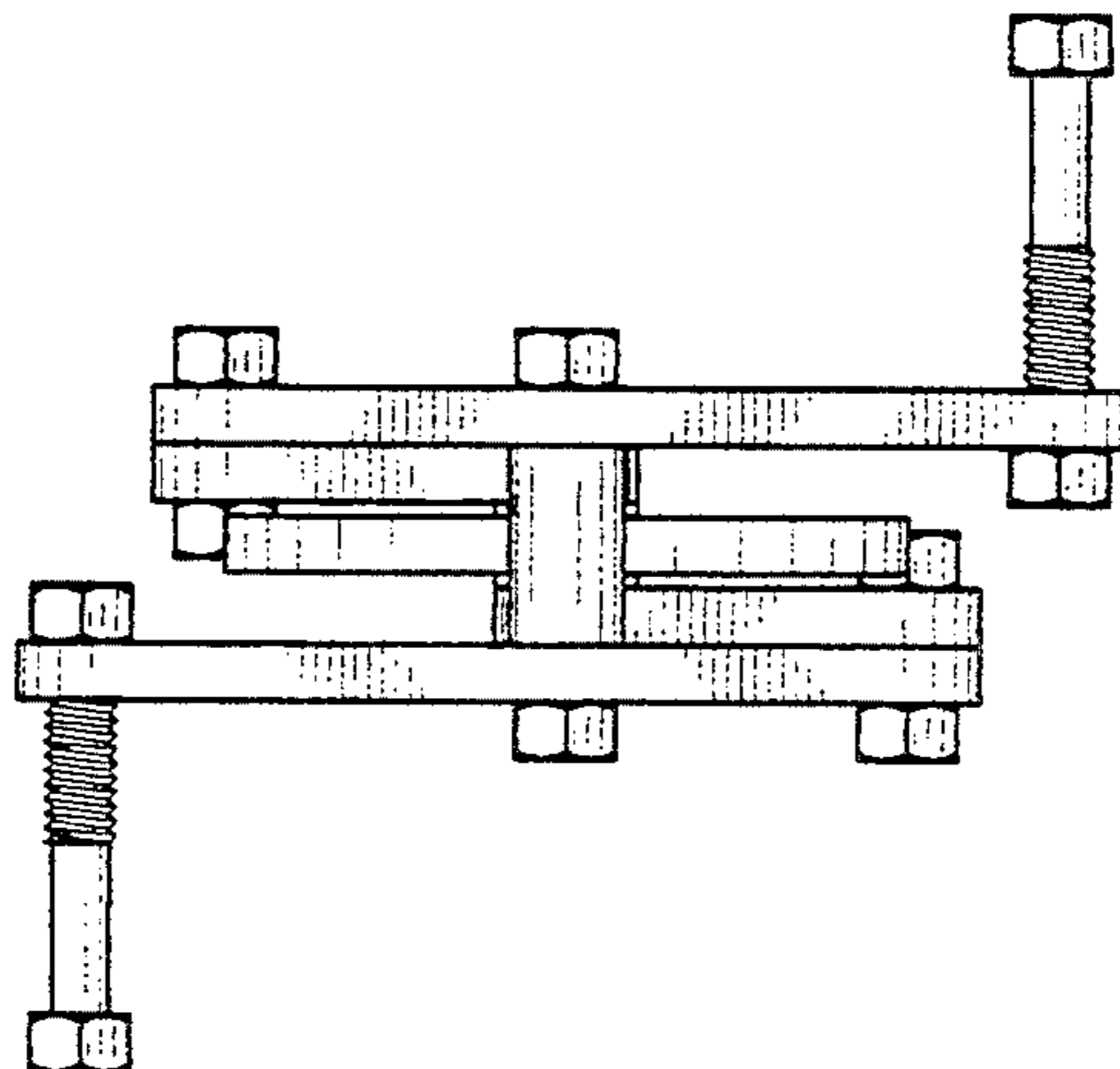

FIG. 7

