



US00D361190S

United States Patent [19]

[11] Patent Number: **Des. 361,190**

Gingras et al.

[45] Date of Patent: **** Aug. 8, 1995**

[54] HANDLE PORTION FOR A TILT TRUCK

[75] Inventors: **Eric Gingras; Glen E. Tomblin**, both of Winchester, Va.

[73] Assignee: **Rubbermaid Commercial Products Inc.**, Winchester, Va.

[**] Term: **14 Years**

[21] Appl. No.: **20,848**

[22] Filed: **Apr. 4, 1994**

[52] U.S. Cl. **D34/27**

[58] Field of Search **D34/12, 27, 16, 24, D34/18; 280/47.26, 47.18, 47.23, 652, 47.27; D8 DIG. 1, DIG. 2, DIG. 7**

[56] **References Cited**

U.S. PATENT DOCUMENTS

D. 309,812	8/1990	Wolters et al.	D34/26
D. 311,621	10/1990	Fuller	D34/18
D. 318,165	7/1991	Ayres	D34/26
D. 327,350	6/1992	Brown et al.	D34/16
D. 337,409	7/1993	Maple et al.	D34/27
2,102,684	12/1937	Dorward	280/51
3,024,547	3/1962	Harrison	37/130
3,858,929	1/1975	Brescia	280/47.12
4,335,897	6/1982	Muller	280/47.18
4,889,360	12/1989	Havlovitz	280/655.1

OTHER PUBLICATIONS

Sell sheet, Yard cart; Stinger, A Division of DeJay

Corp., 3300 PGA Boulevard, Suite 450, Palm Beach Gardens, Florida 33410. Publication date at least as early as Nov., 1992.

P. 13, Tilt trucks; Chem-tainer Industries, Inc., 361 Neptune Avenue, North Babylon, New York 22704. Publication date 1988.

Pp. 4 and 6, Tilt trucks and self-dumping hoppers; Rubbermaid Commercial Products Inc., 3124 Valley Avenue, Winchester, Virginia 22601. Publication date 1992.

Primary Examiner—Kay H. Chin

Attorney, Agent, or Firm—Richard B. O'Planick; Lisa B. Riedesel

[57] **CLAIM**

The ornamental design for a handle portion for a tilt truck, as shown and described.

DESCRIPTION

FIG. 1 is a top rear left side perspective view of a handle portion for a tilt truck showing our new design. The broken lines are for illustrative purposes only and form no part of the claimed design;

FIG. 2 is a left side elevational view thereof; the right side elevational view being a mirror image;

FIG. 3 is a top plan view thereof;

FIG. 4 is a bottom plan view thereof;

FIG. 5 is a rear elevational view thereof; and,

FIG. 6 is a front elevational view thereof.

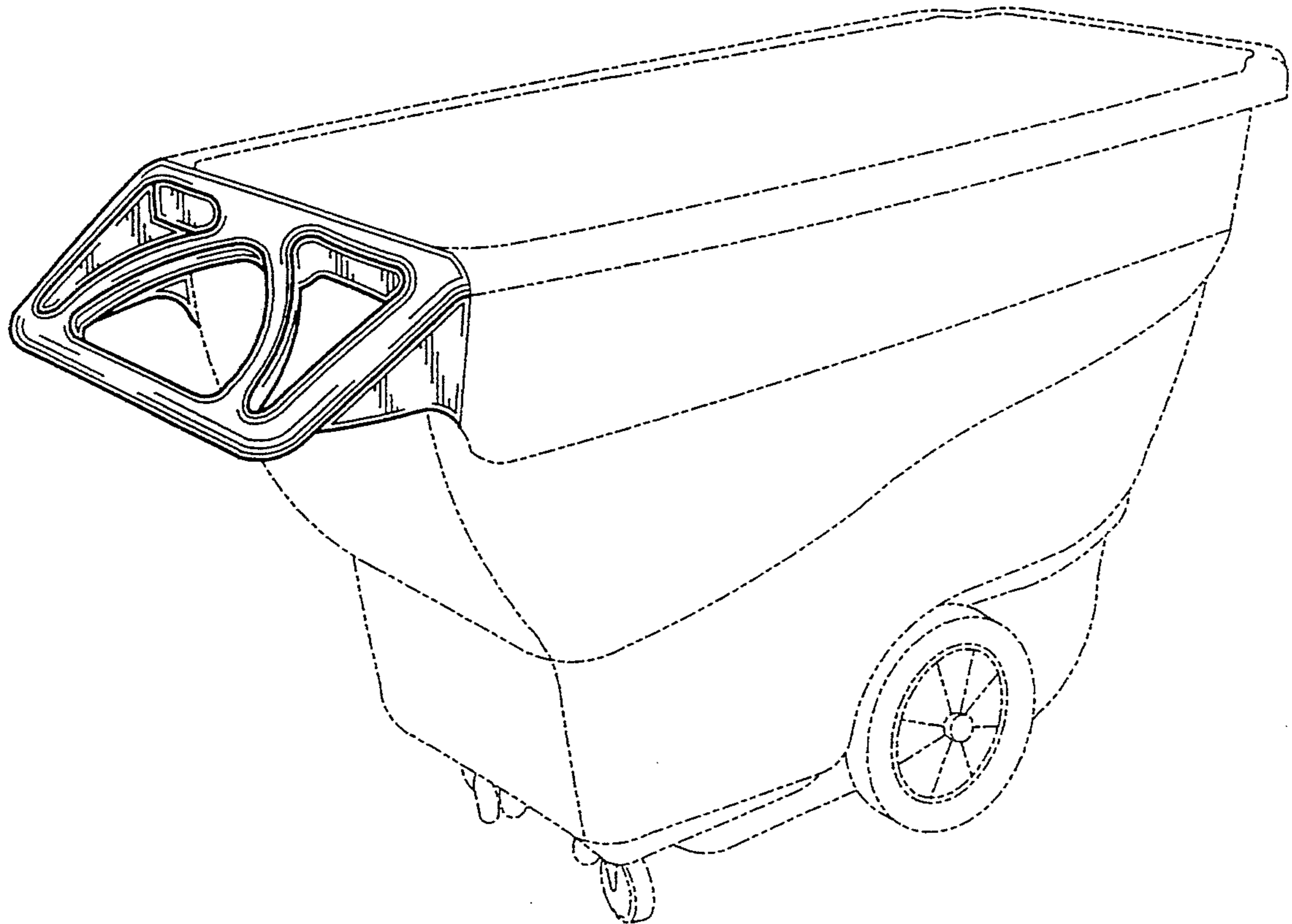

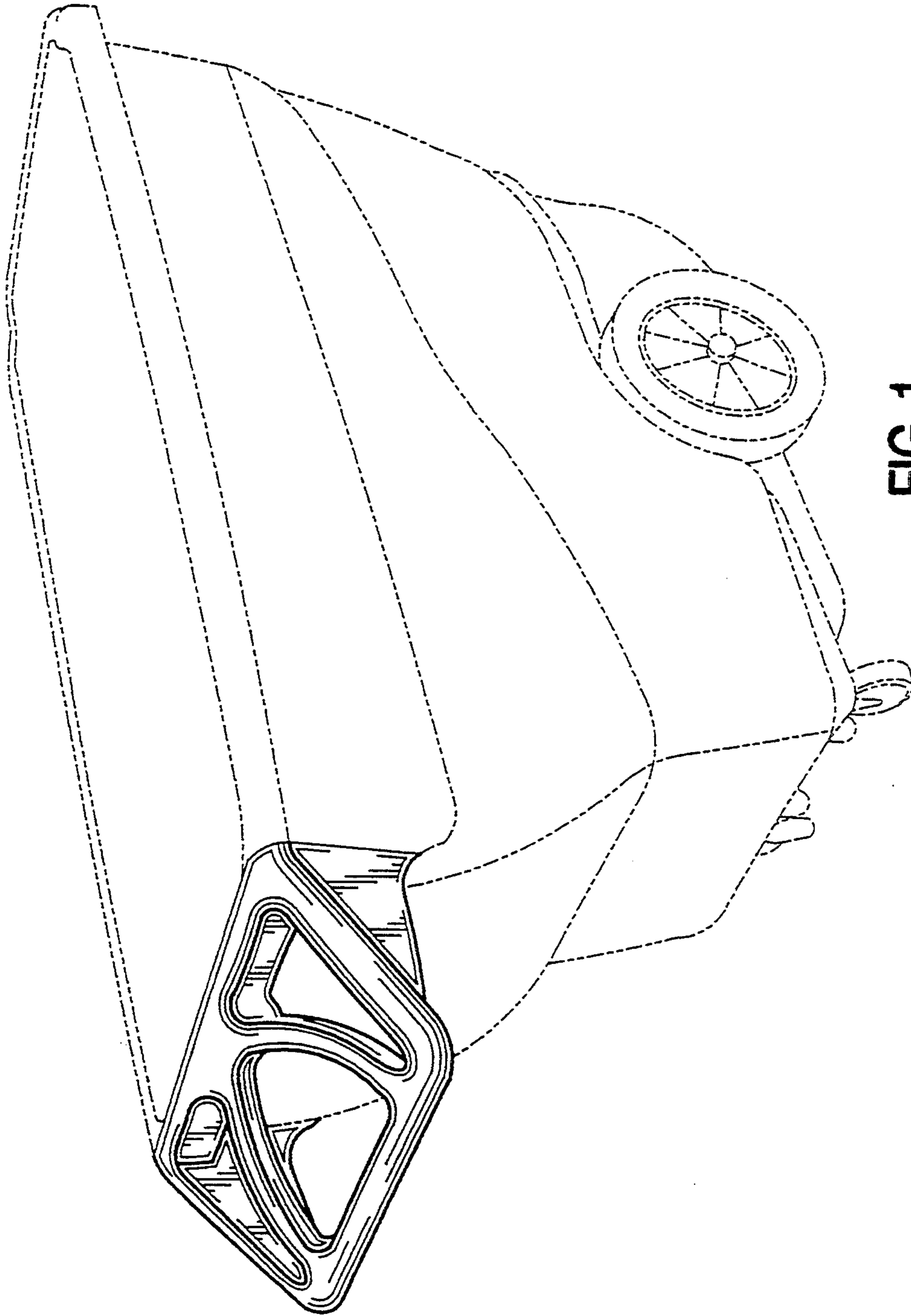

FIG. 1

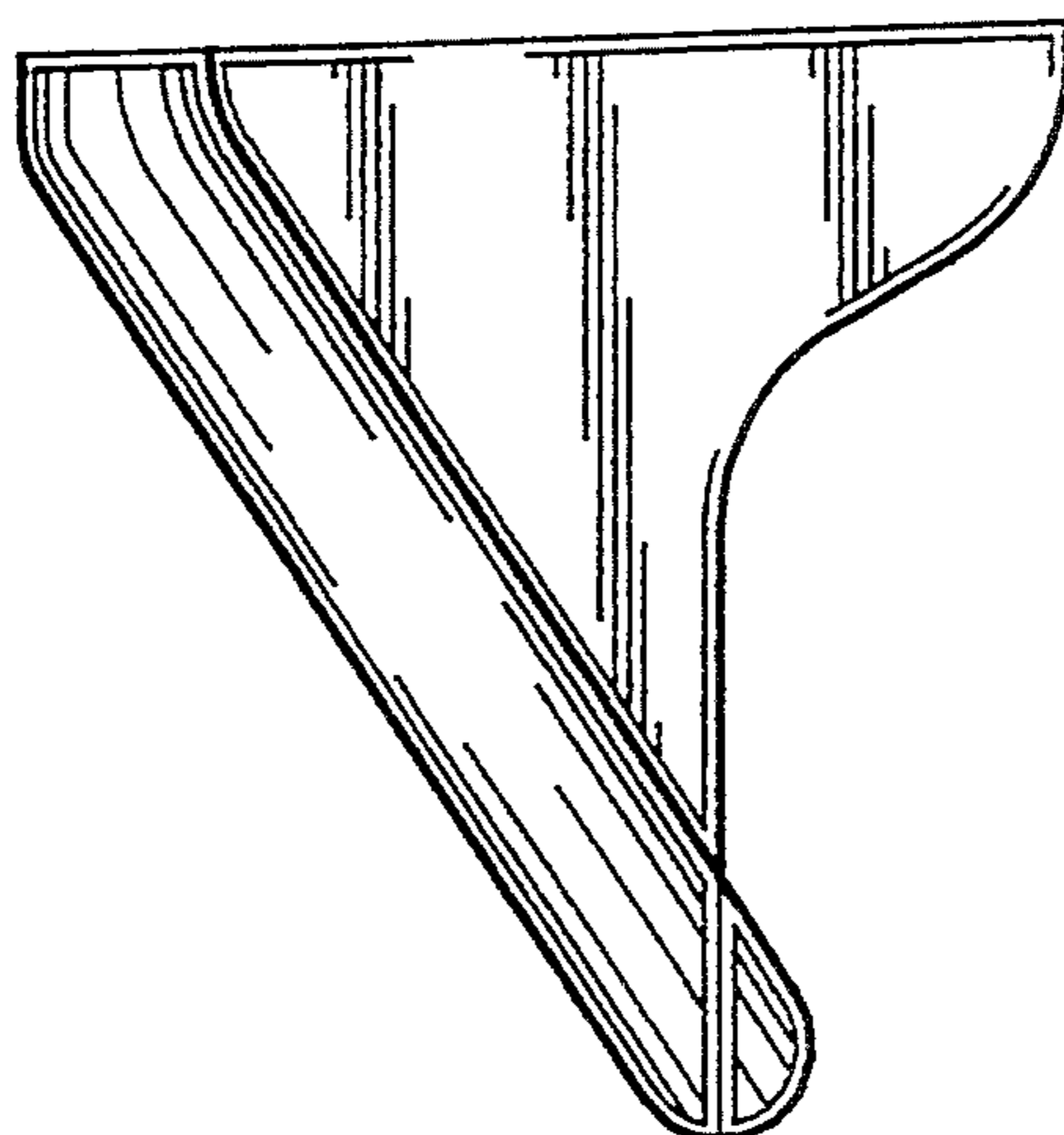

FIG. 2

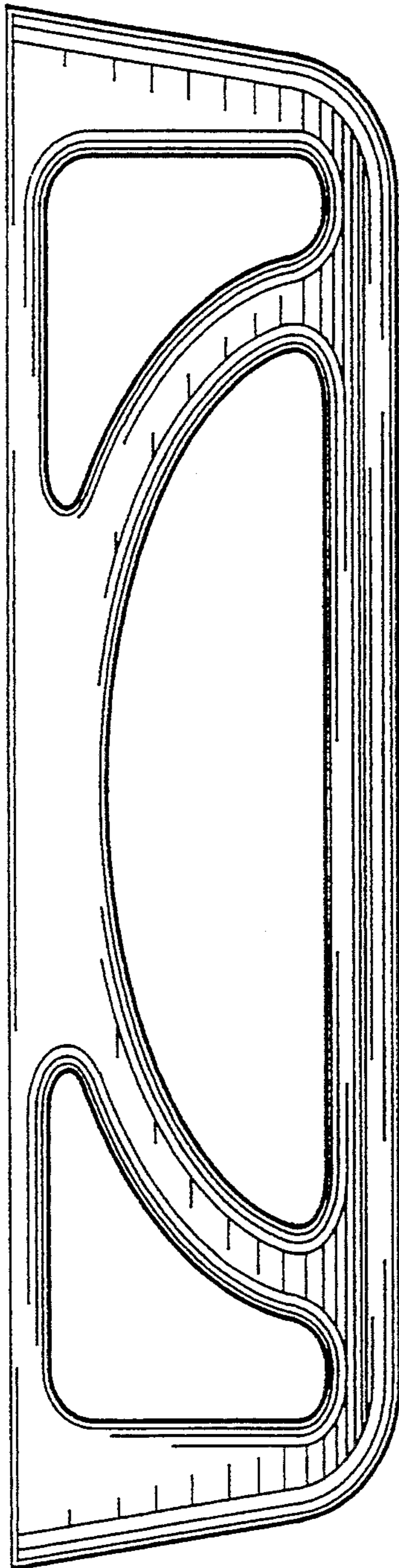

FIG. 3

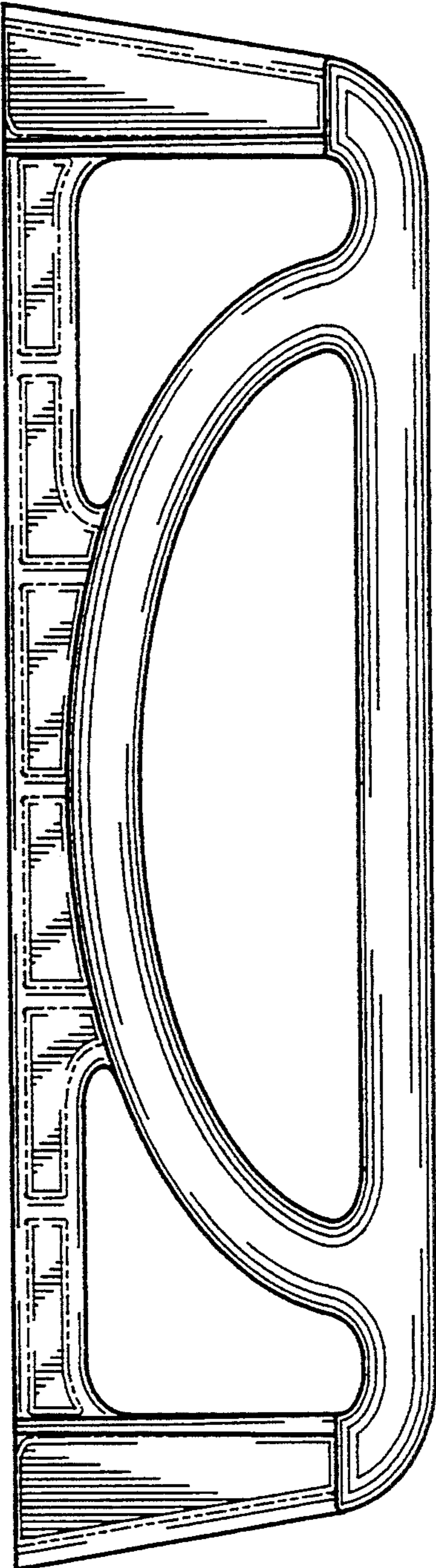

FIG. 4

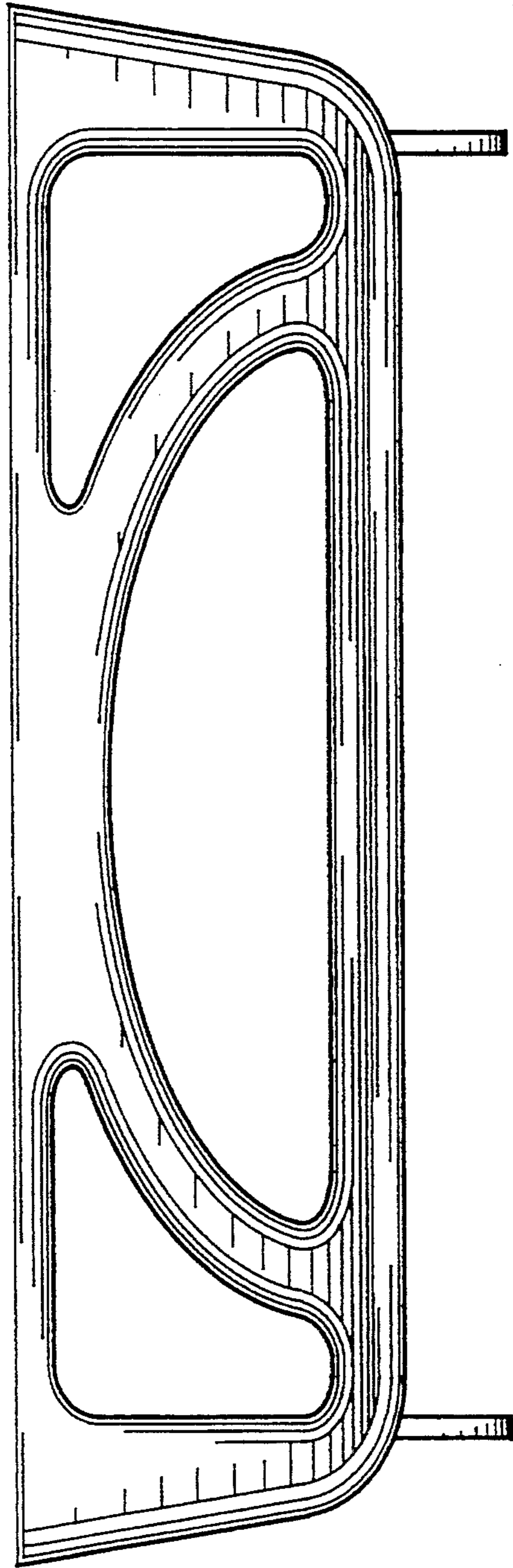

FIG. 5

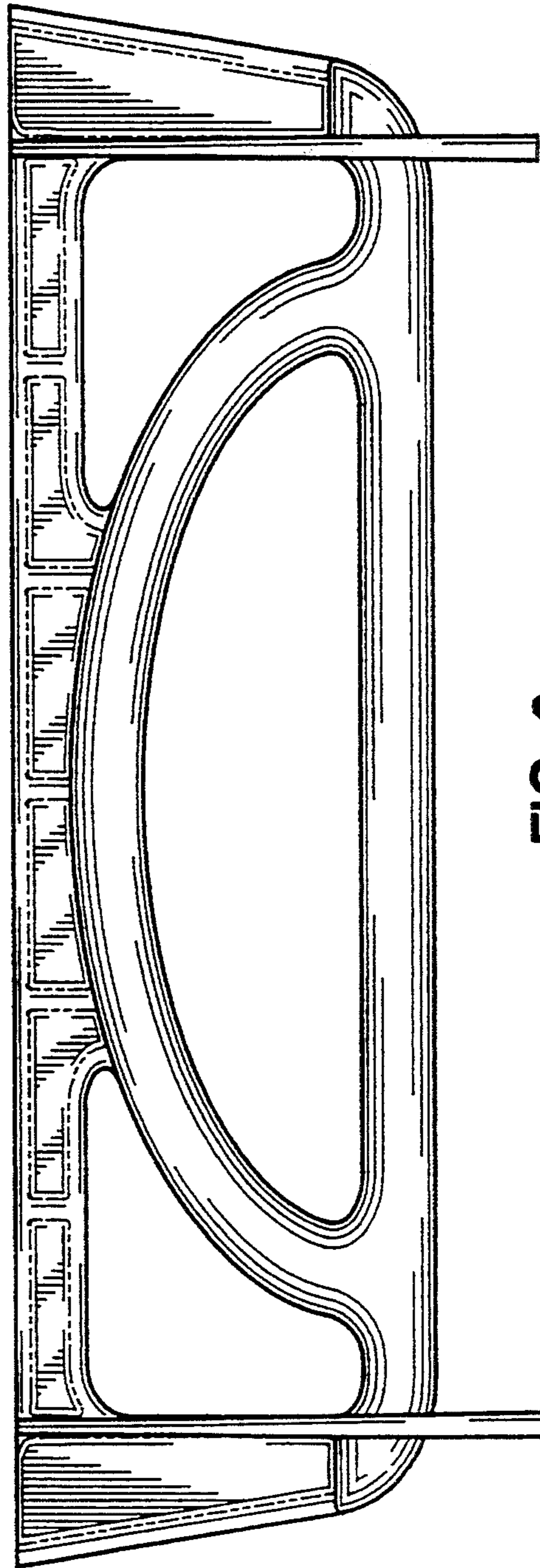

FIG. 6