



US00D361179S

# United States Patent [19]

[11] Patent Number: **Des. 361,179**

Moine et al.

[45] Date of Patent: **\*\* Aug. 8, 1995**

[54] **COMBINED WET AND DRY VACUUM CLEANER**

[75] Inventors: **David W. Moine**, North Canton;  
**Darwin T. McKnight**, Louisville;  
**Ronald J. Stephens**, Rittman; **Richard A. Wareham**, North Canton, all of Ohio

[73] Assignee: **The Hoover Company**, North Canton, Ohio

[\*\*] Term: **14 Years**

[21] Appl. No.: **8,532**

[22] Filed: **May 19, 1993**

[52] U.S. Cl. .... **D32/23**

[58] Field of Search ..... **D32/21, 23-24; 15/320-321, 323, 327.1-327.7, 353, 246.5**

[56] **References Cited**

**U.S. PATENT DOCUMENTS**

D. 208,398	3/1967	Otto et al. ....	D32/16
D. 255,357	6/1980	Brooks et al. ....	D32/23
D. 261,515	10/1981	Schaefer et al. ....	D32/23
D. 280,768	9/1985	Ferraris et al. ....	D32/23
D. 286,336	10/1986	Berfield et al. ....	D32/23
D. 305,816	1/1990	Berfield et al. ....	D32/15
D. 307,655	5/1990	Hinklin et al. ....	D32/15
D. 324,930	3/1992	Pino .....	D32/23
D. 334,376	2/1994	Worwag .....	D32/23
D. 338,294	8/1993	Kohler .....	D32/23

3,570,222	3/1971	Dudek .....	55/472
3,775,951	12/1973	Eicholz et al. ....	55/417
4,654,926	4/1987	McCambridge .....	15/327
4,799,285	1/1989	Berfield .....	15/327
4,836,753	6/1989	Berfield et al. ....	417/236
5,183,982	2/1993	Smith .....	200/61.85

**OTHER PUBLICATIONS**

Montgomery Ward Cat., Fall & Winter 1975, p. 695, "Wet/Dry Vacuum Cleaners".  
 Best Products Cat., 1981/82, p. 199. "Items 5-7 Vac. Cleaners".  
 Sears 1983, Spring & Summer, p. 839. "Items 4-5 wet-dry vac cleaners".  
 General Electric Sales Literature For "Master Vac" Furnace and Boiler Cleaner Dated Jan. 28, 1949.  
 Sears 1993 Spring/Summer Catalog p. 1229.

*Primary Examiner*—Ruth McInroy

[57] **CLAIM**

The ornamental design for a combined wet and dry vacuum cleaner, as shown and described.

**DESCRIPTION**

FIG. 1 is a front elevational view of a combined wet and dry vacuum cleaner showing our new design;  
 FIG. 2 is a left side elevational view thereof;  
 FIG. 3 is a top plan view thereof;  
 FIG. 4 is a bottom plan view thereof;  
 FIG. 5 is a rear elevational view thereof; and,  
 FIG. 6 is a right side elevational view thereof.

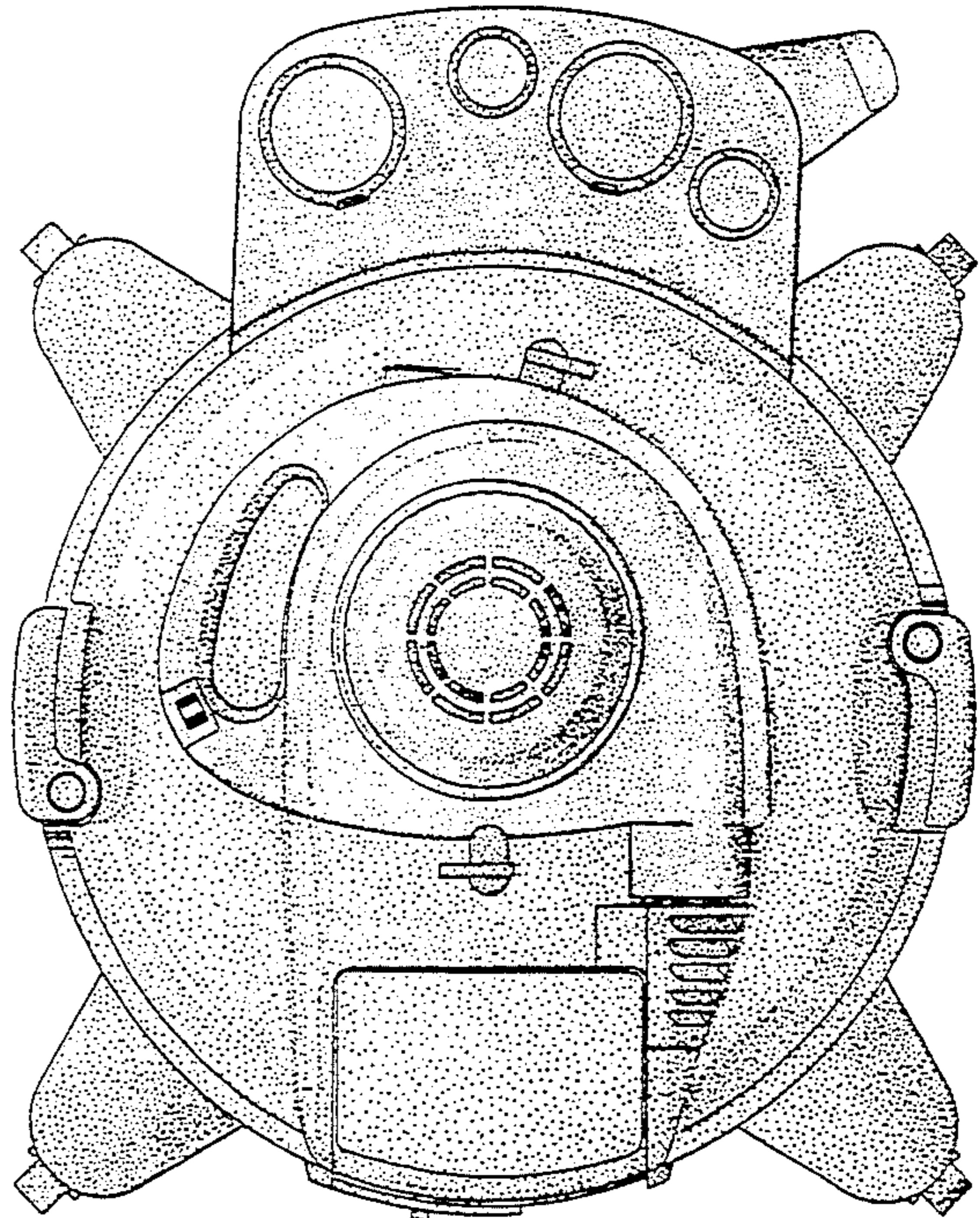
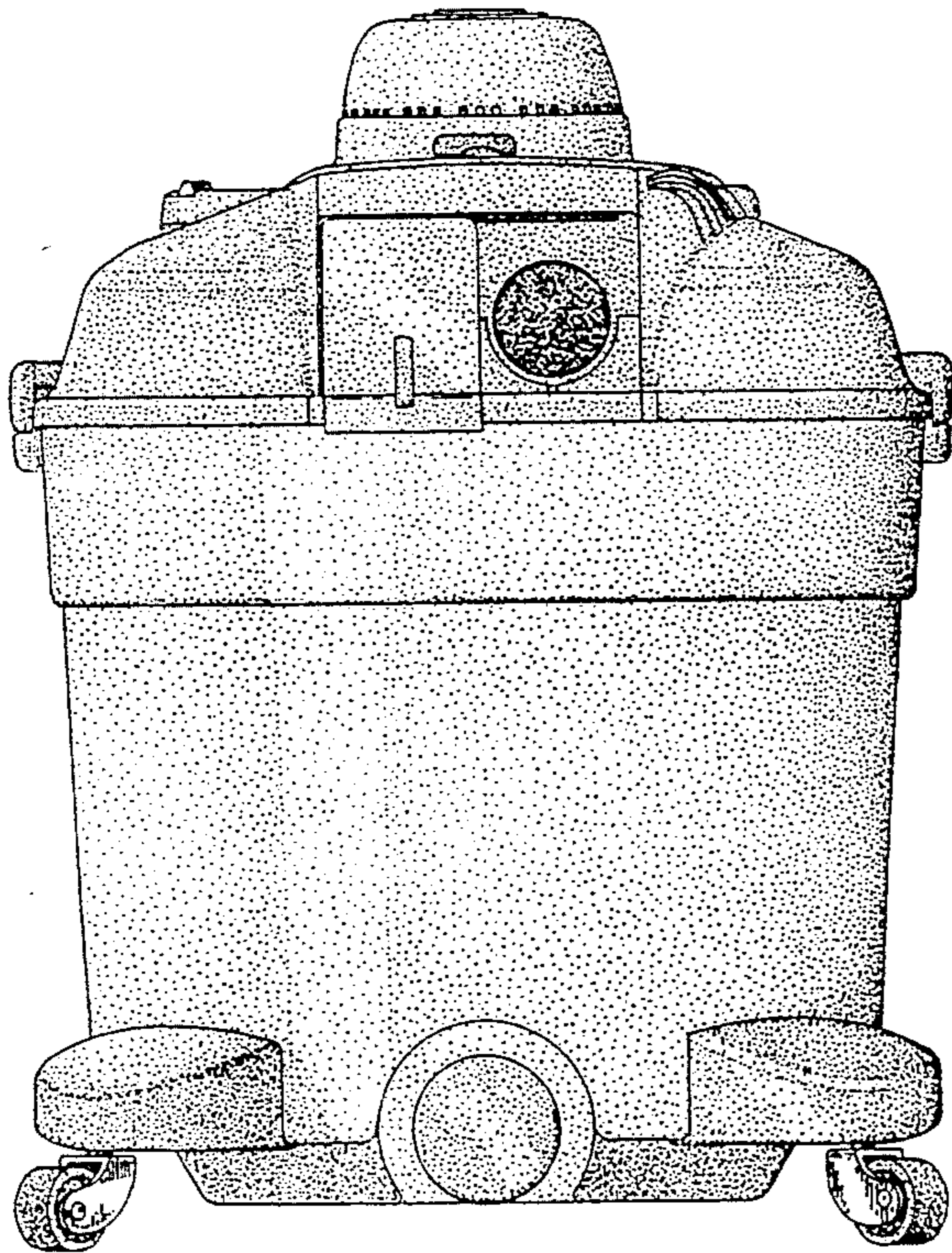

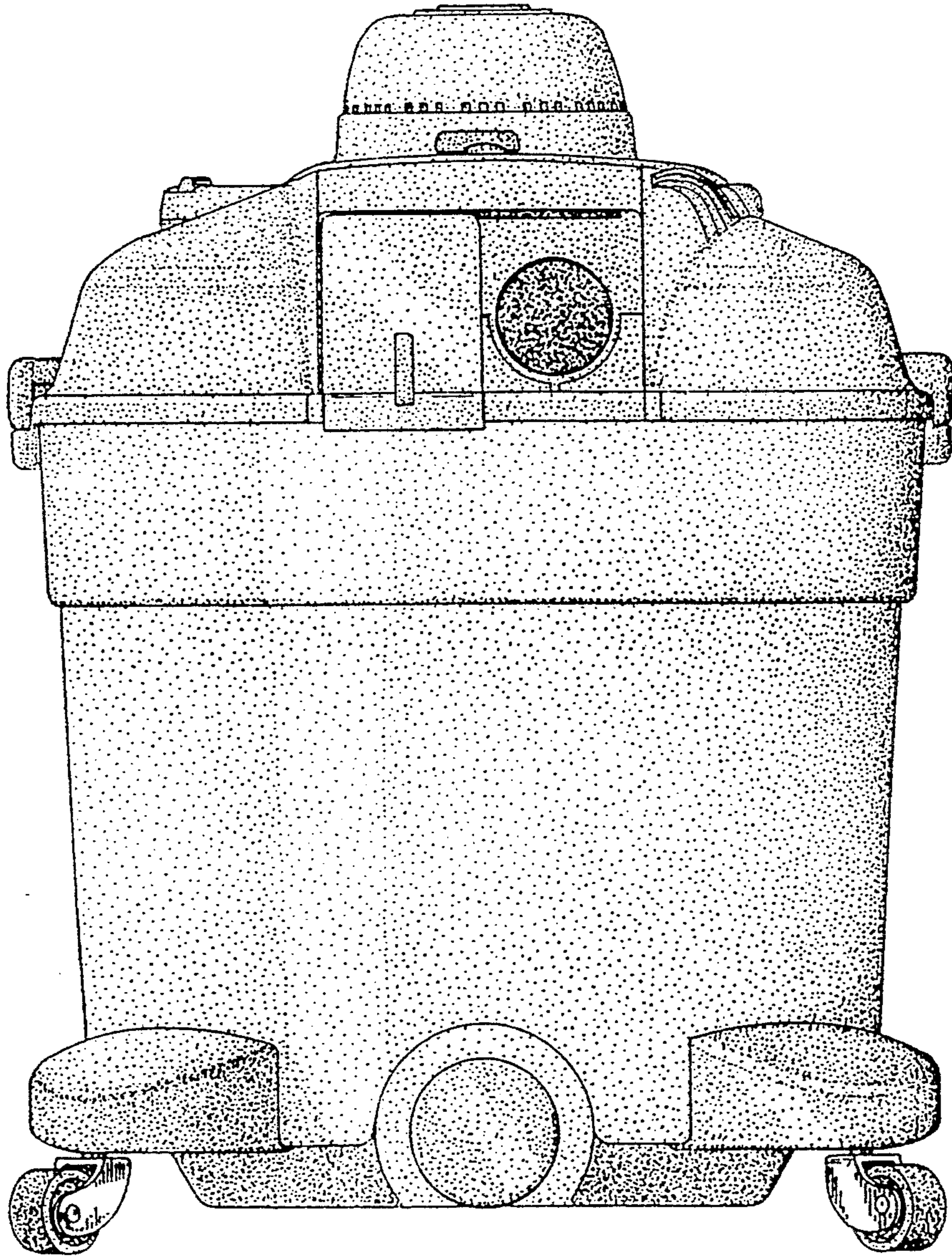

FIG. -1

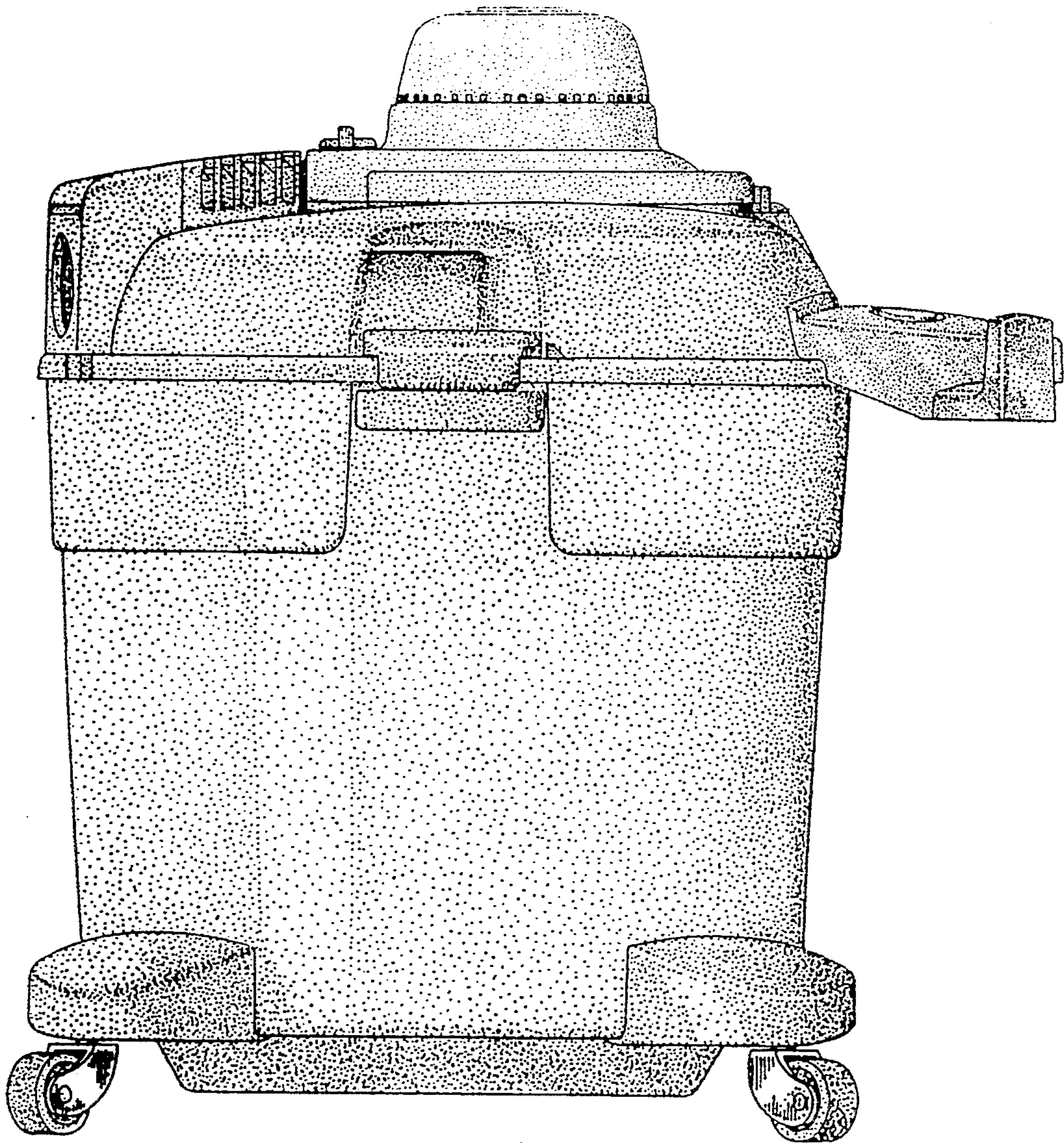

FIG. - 2

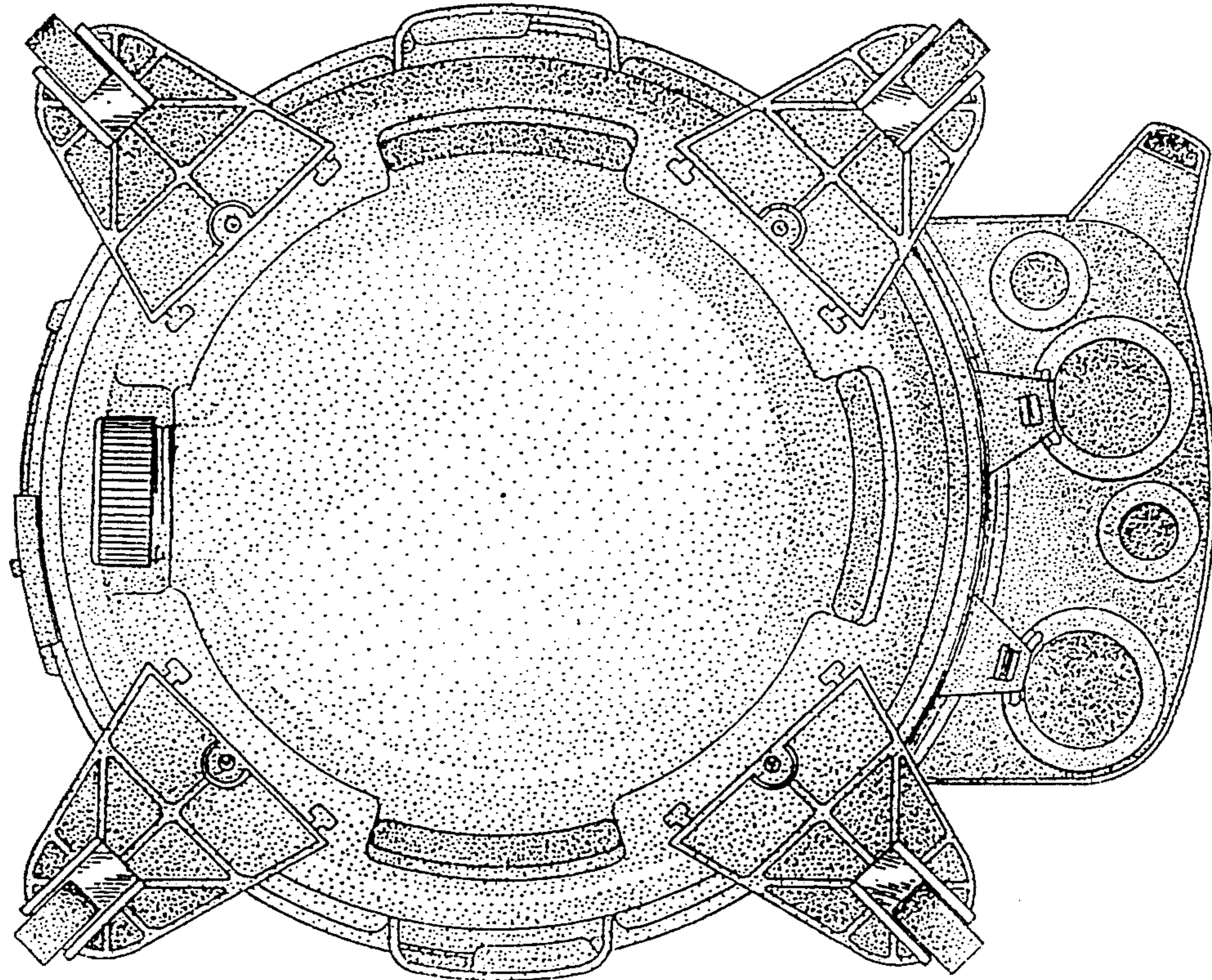

FIG. -4

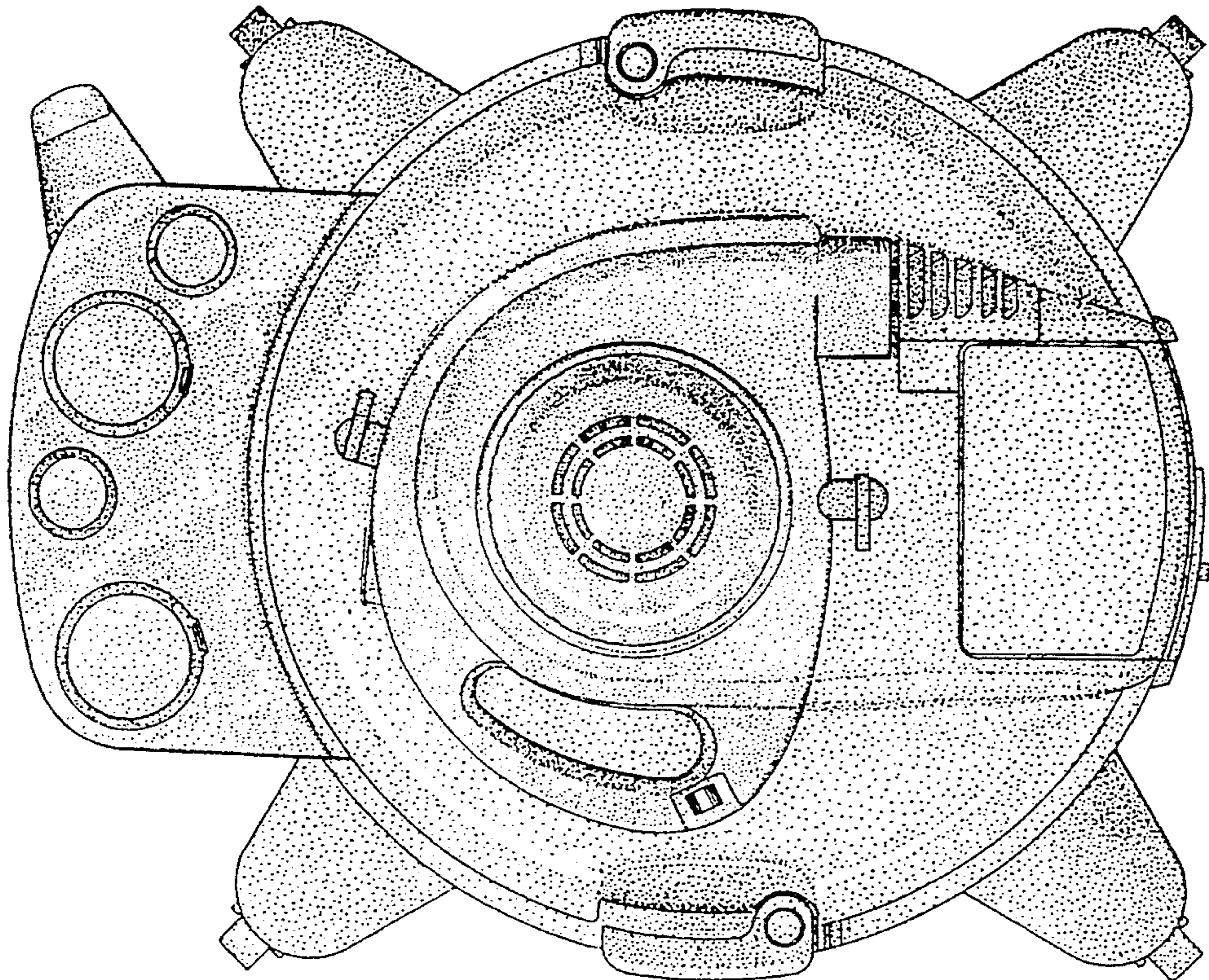

FIG. -3

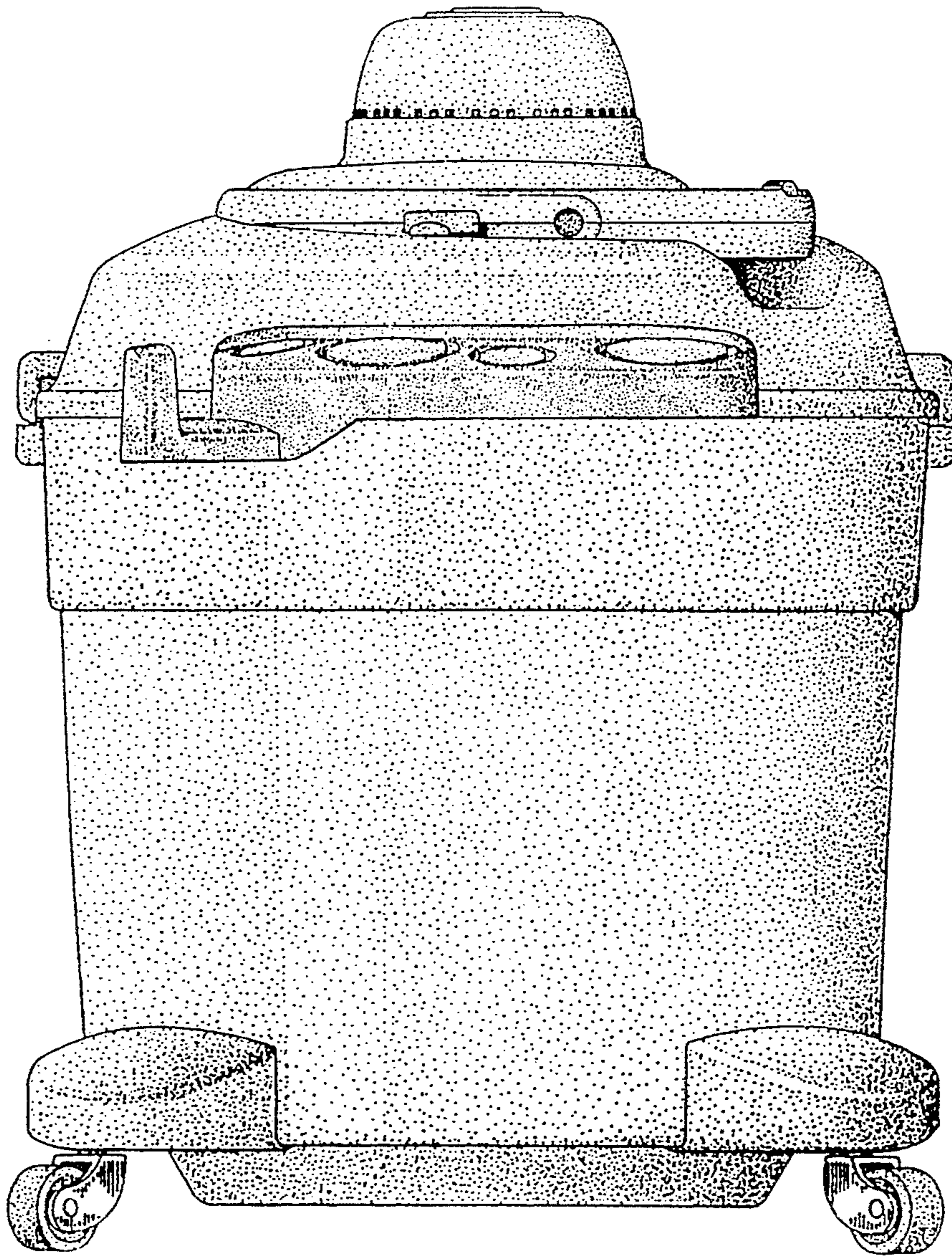

FIG. - 5

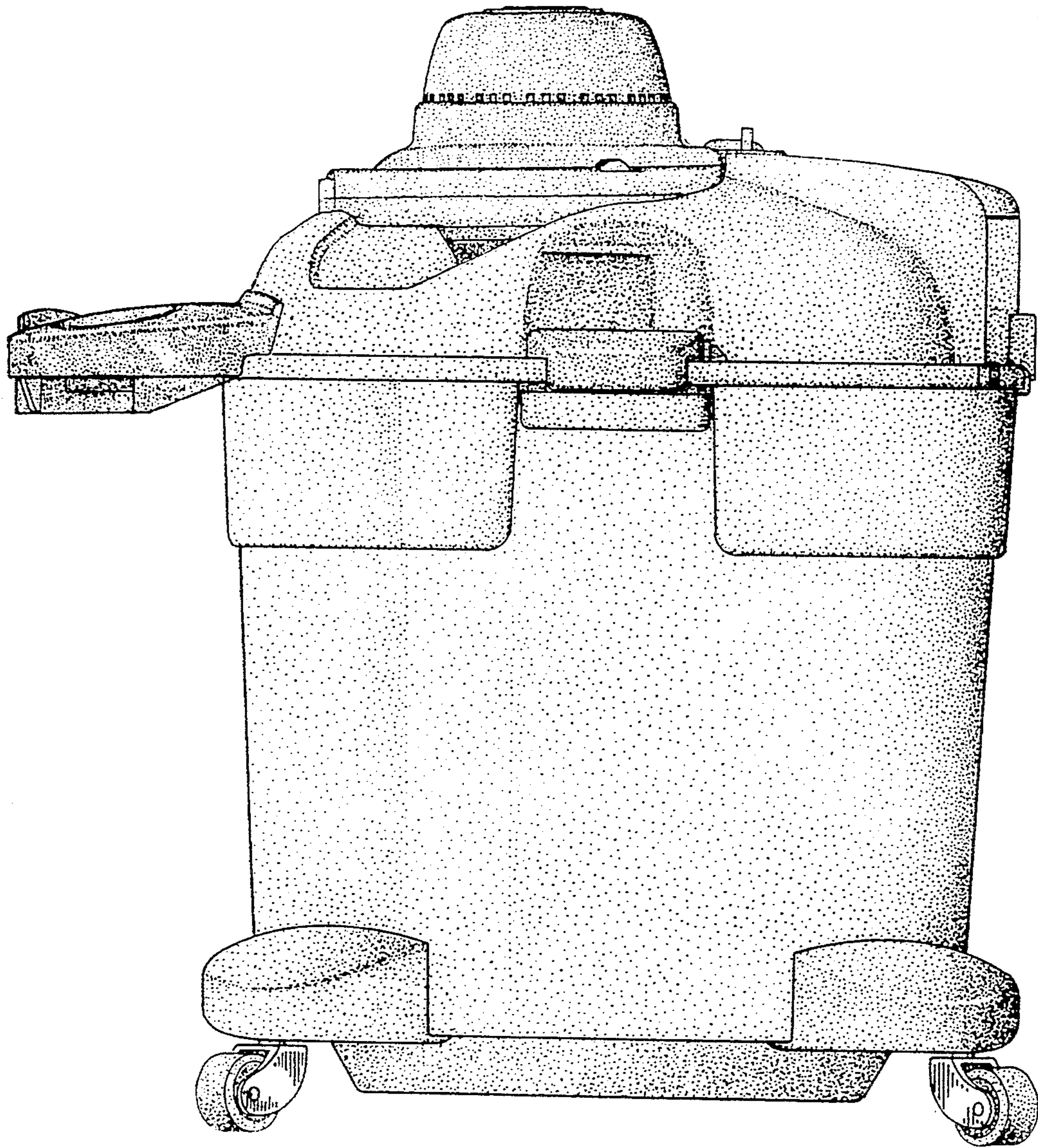

FIG.-6