



US00D361047S

# United States Patent [19]

[11] Patent Number: **Des. 361,047**

Repke

[45] Date of Patent: **\*\* Aug. 8, 1995**

[54] TRAILER

[57] CLAIM

[76] Inventor: **Neil D. Repke**, Box 326, Palmer, Mich. 49871

The ornamental design for a trailer, as shown and described.

[\*\*] Term: **14 Years**

### DESCRIPTION

[21] Appl. No.: **11,722**

FIG. 1 is a front elevational view of a trailer showing my new design;  
 FIG. 2 is a rear elevational view of the invention;  
 FIG. 3 is a right side elevational view of the invention, the left side elevational view being a mirror image;  
 FIG. 4 is a top plan view of the invention;  
 FIG. 5 is a bottom plan view of the invention;  
 FIG. 6 is a front perspective view of the invention;  
 FIG. 7 is a rear perspective view of the invention;  
 FIG. 8 is a front elevational view of a trailer showing a second embodiment of my new design;  
 FIG. 9 is a rear elevational view of FIG. 8;  
 FIG. 10 is a right side elevation view of FIG. 8; the left side elevational view being a mirror image;  
 FIG. 11 is a top plan view of FIG. 8;  
 FIG. 12 is a bottom plan view of FIG. 8;  
 FIG. 13 is a front perspective view of FIG. 8; and,  
 FIG. 14 is a rear perspective view of FIG. 8.

The trailer tires shown in FIG. 1, and the trailer hitch shown in FIG. 3, form no part of the present invention, and are shown in phantom lines for purposes of illustration only.

[22] Filed: **Aug. 13, 1993**

[52] U.S. Cl. .... **D12/101**

[58] Field of Search ..... D12/105, 101; 280/63, 280/656; 296/181, 184

### [56] References Cited

#### U.S. PATENT DOCUMENTS

D. 274,507	7/1984	Wilson	.....	D12/105
D. 286,992	12/1986	Doering	.....	D12/105
D. 325,549	4/1992	Jarvis	.....	D12/105
3,578,806	5/1971	Tonelli	.....	D12/105

*Primary Examiner*—A. Hugo Word

*Assistant Examiner*—M. Brown

*Attorney, Agent, or Firm*—Masrshall & Melhorn

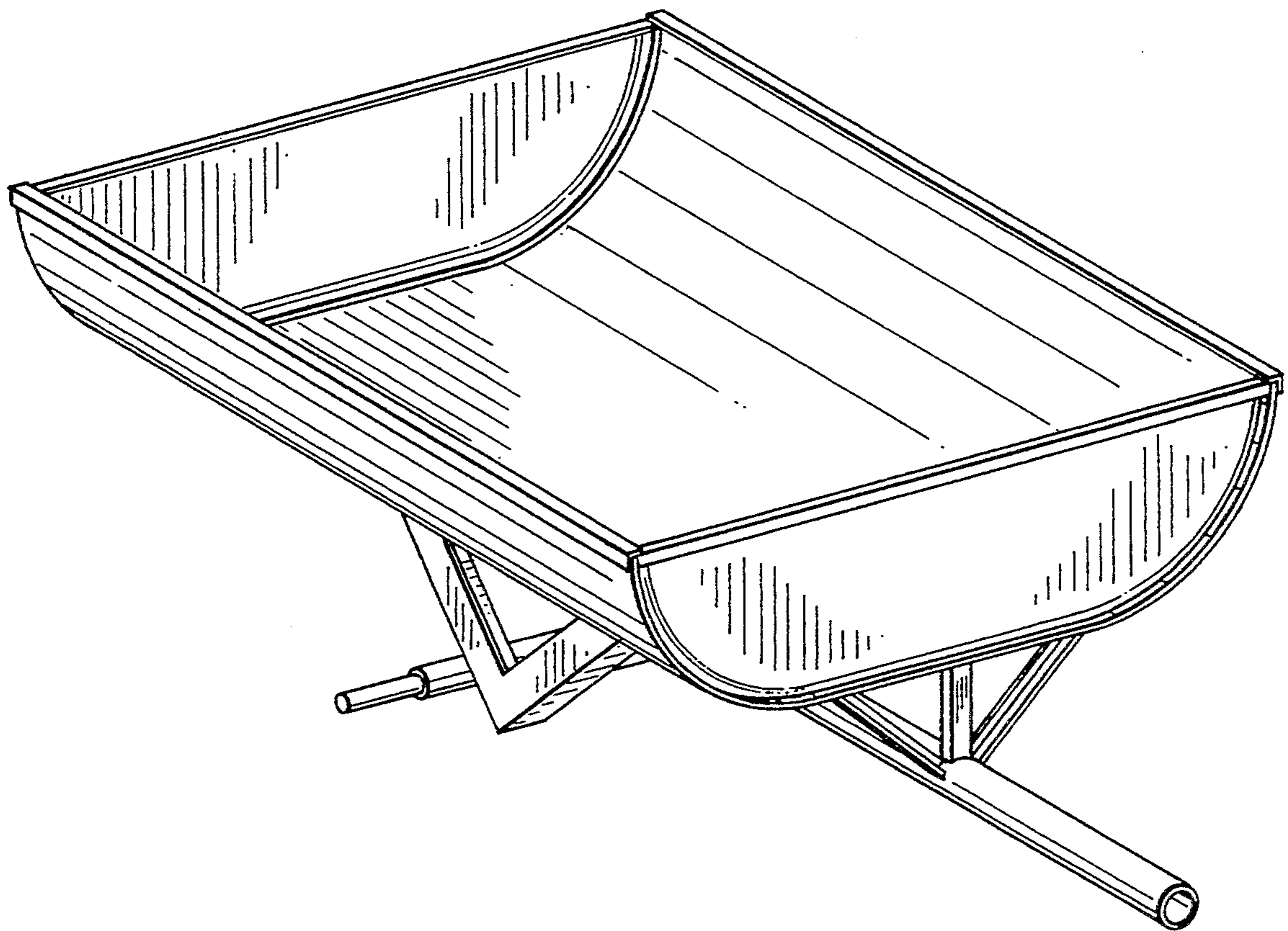

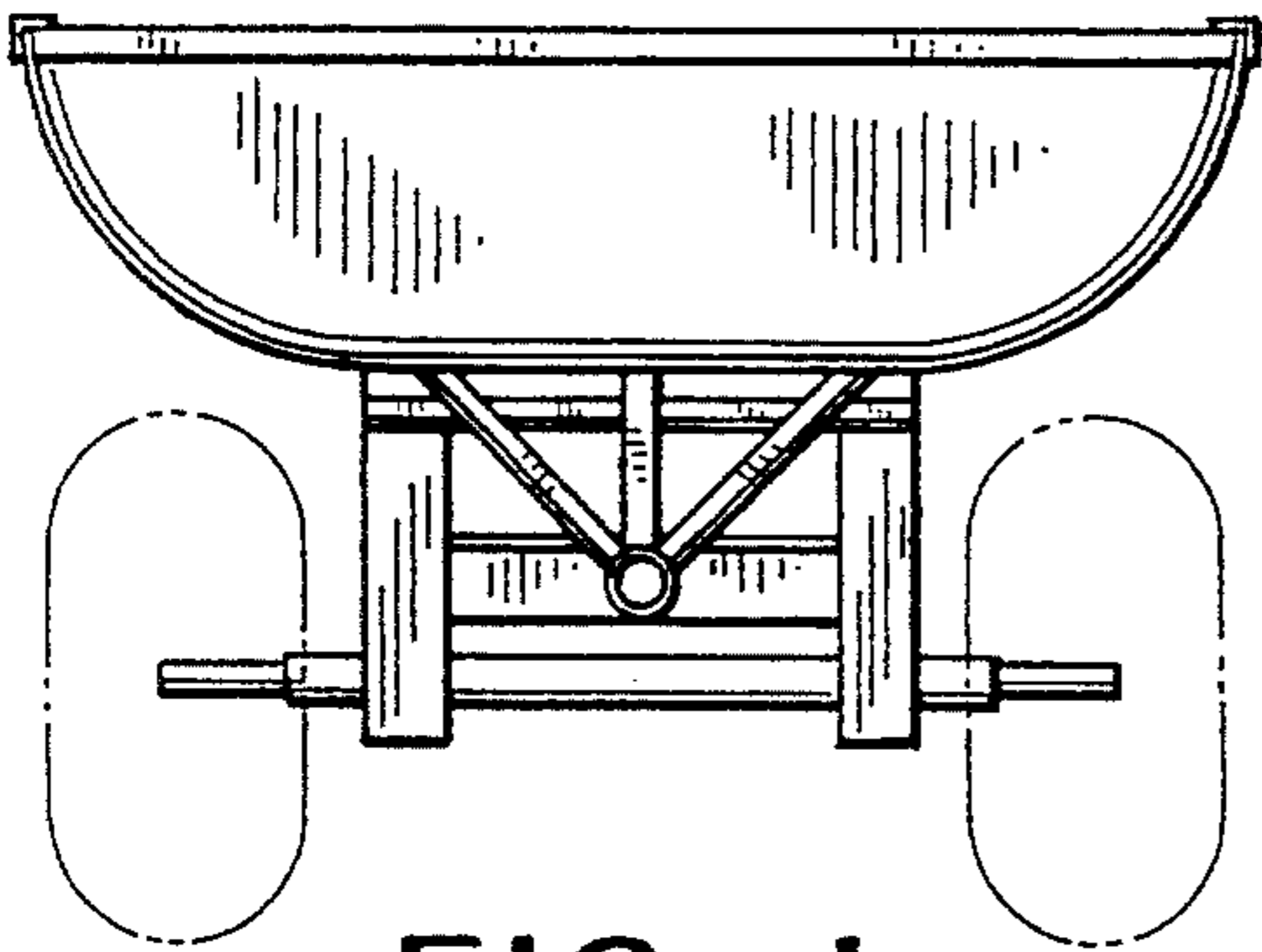

FIG. 1

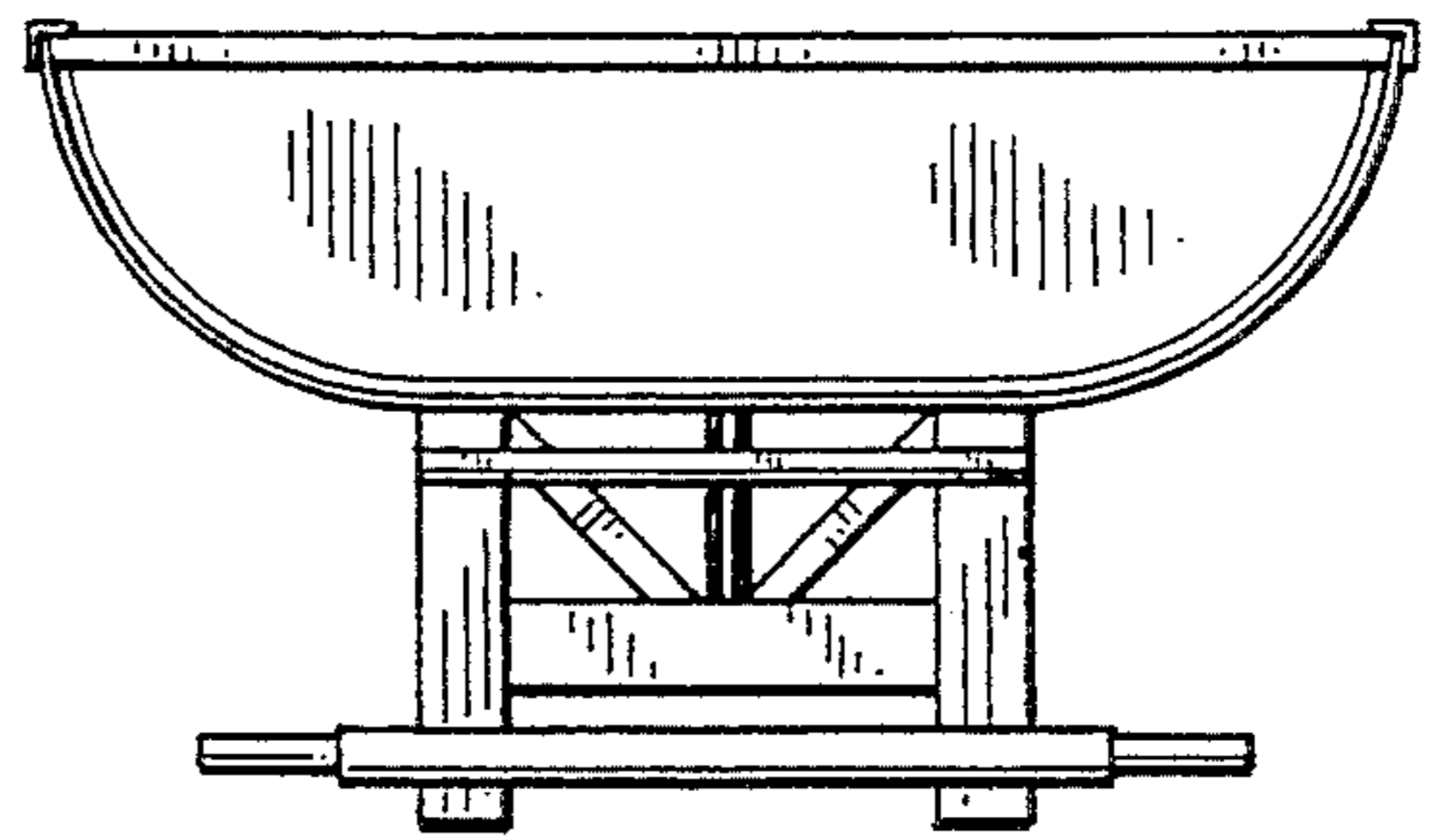

FIG. 2

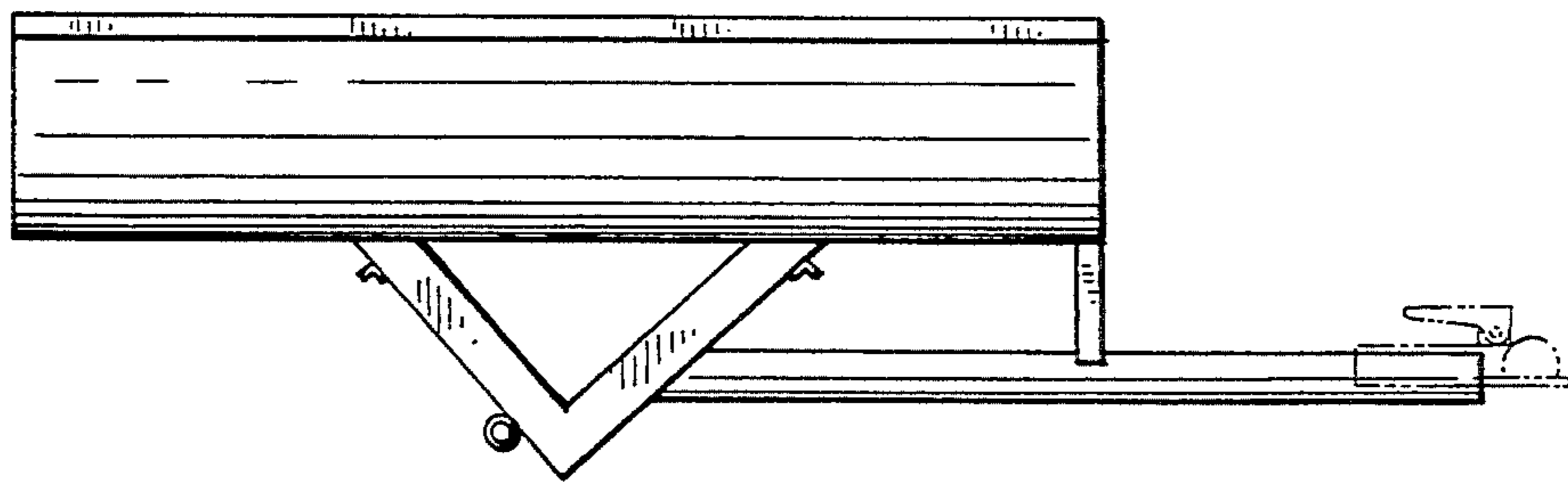

FIG. 3

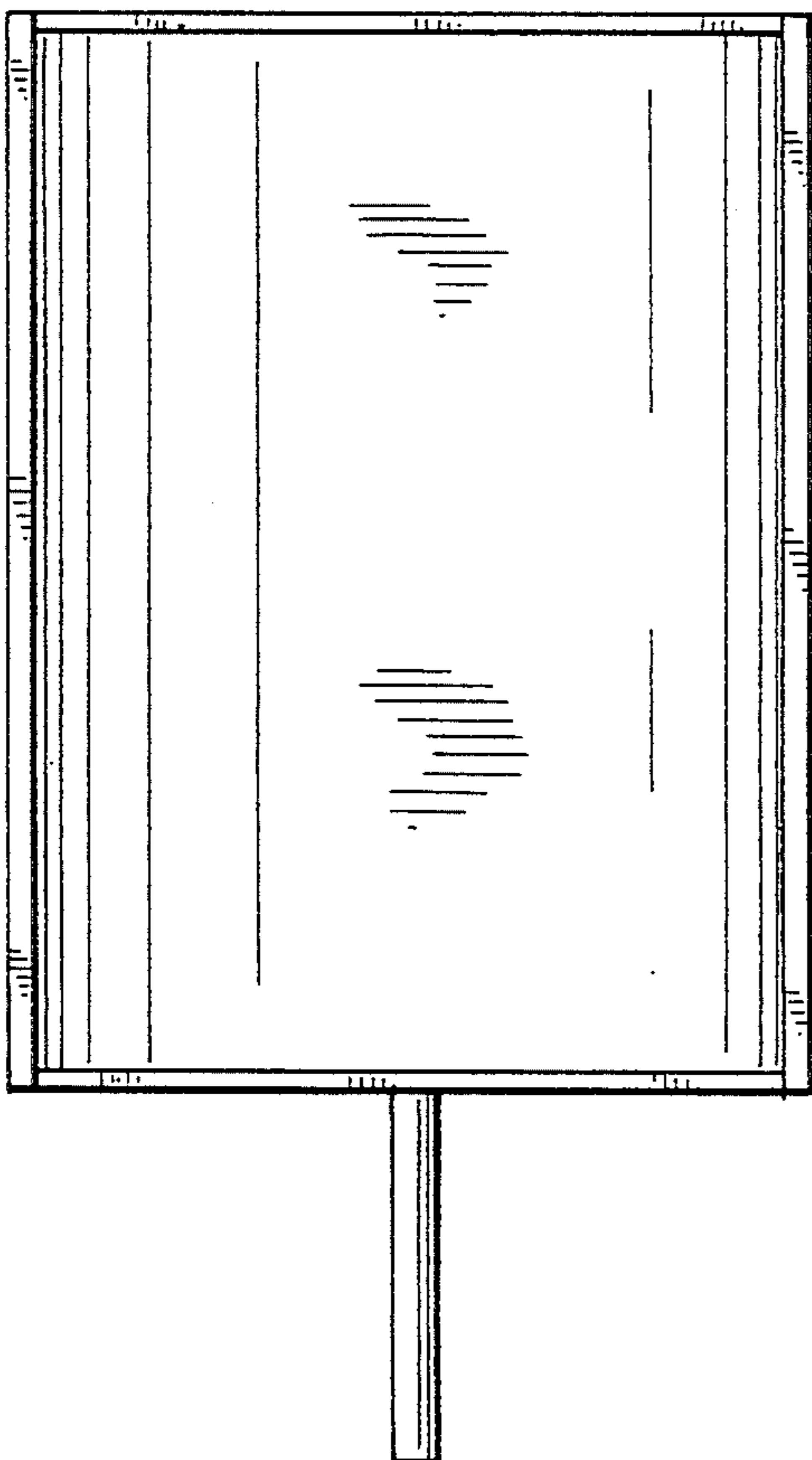

FIG. 4

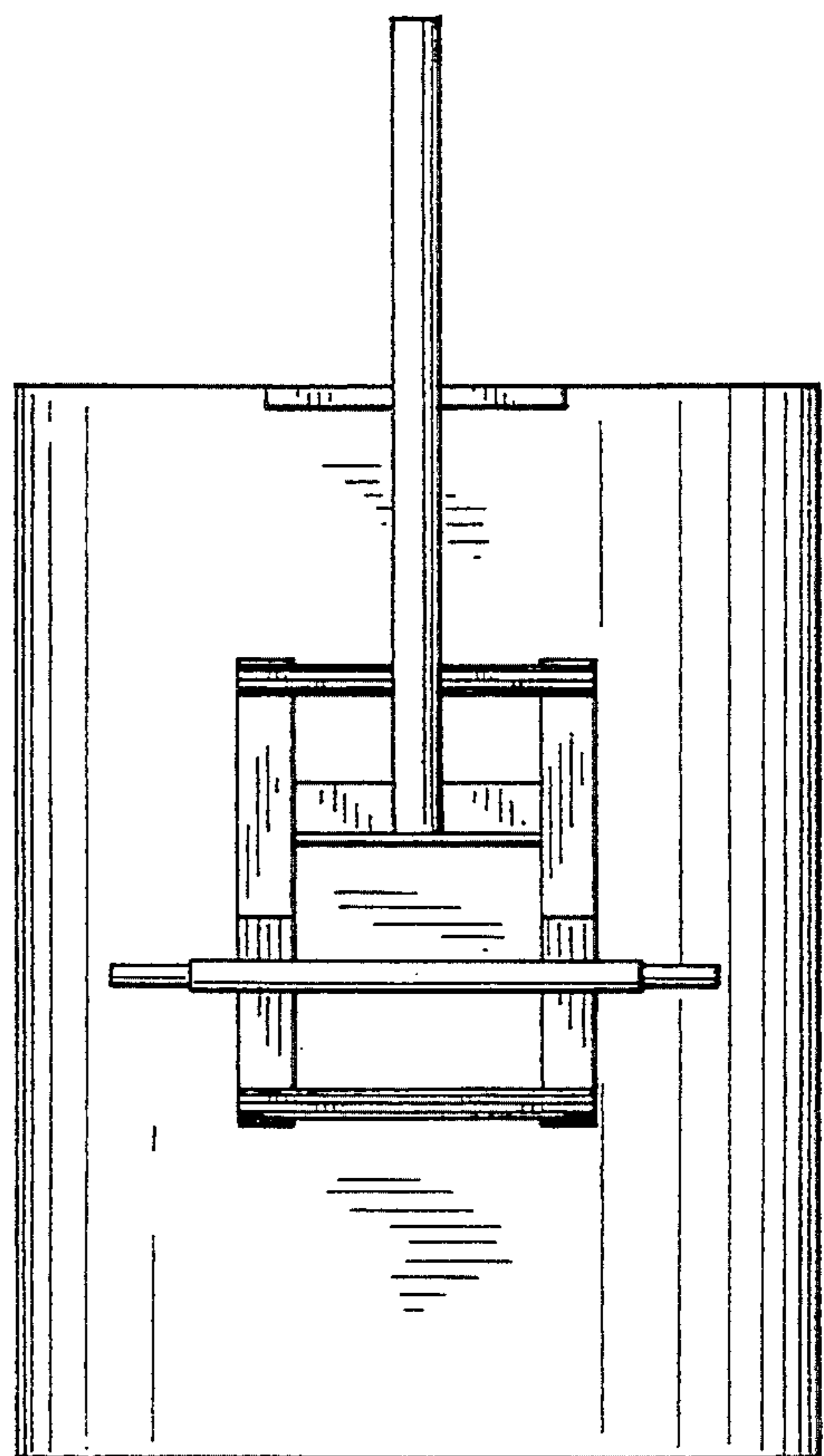

FIG. 5

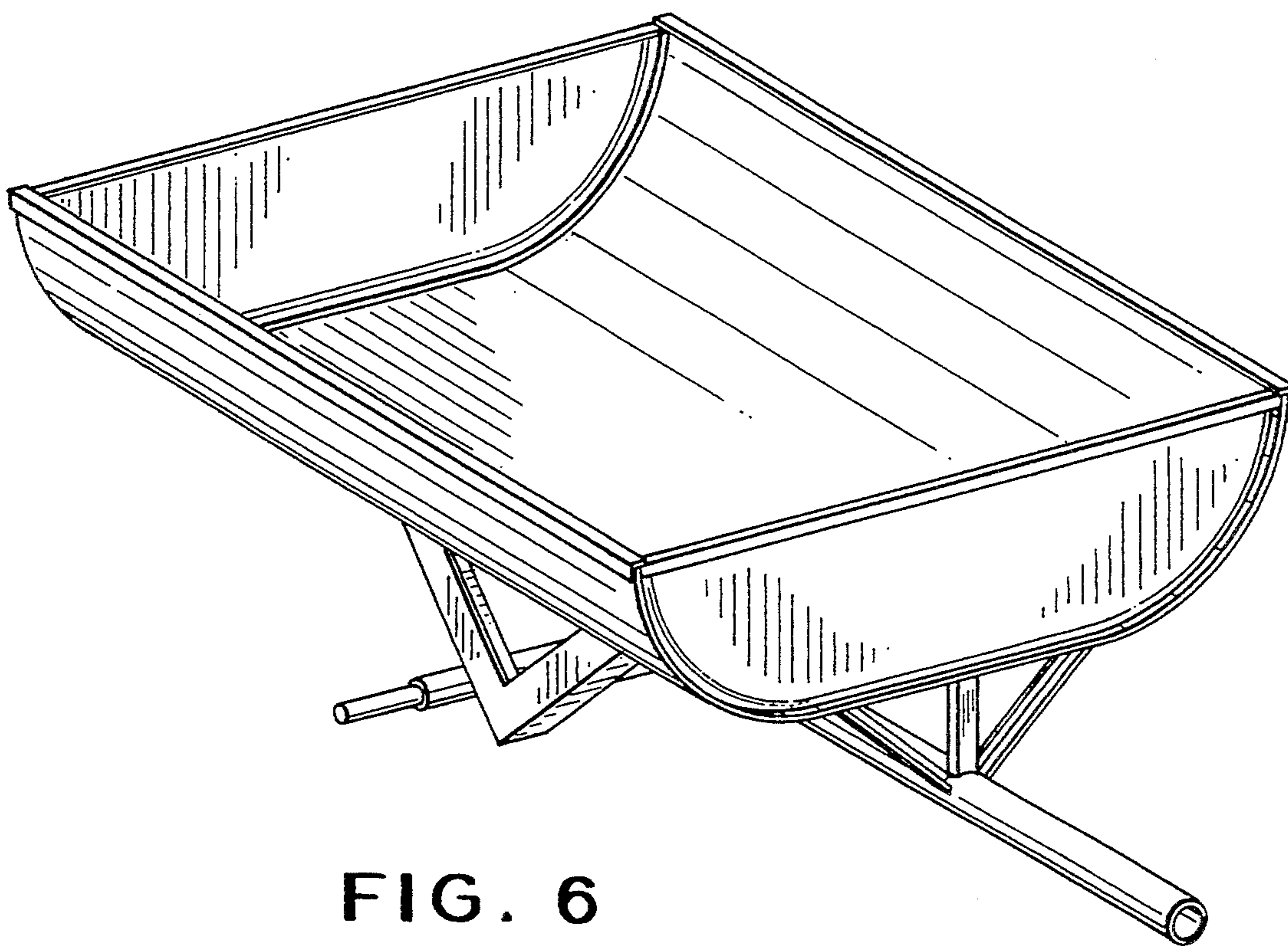

FIG. 6

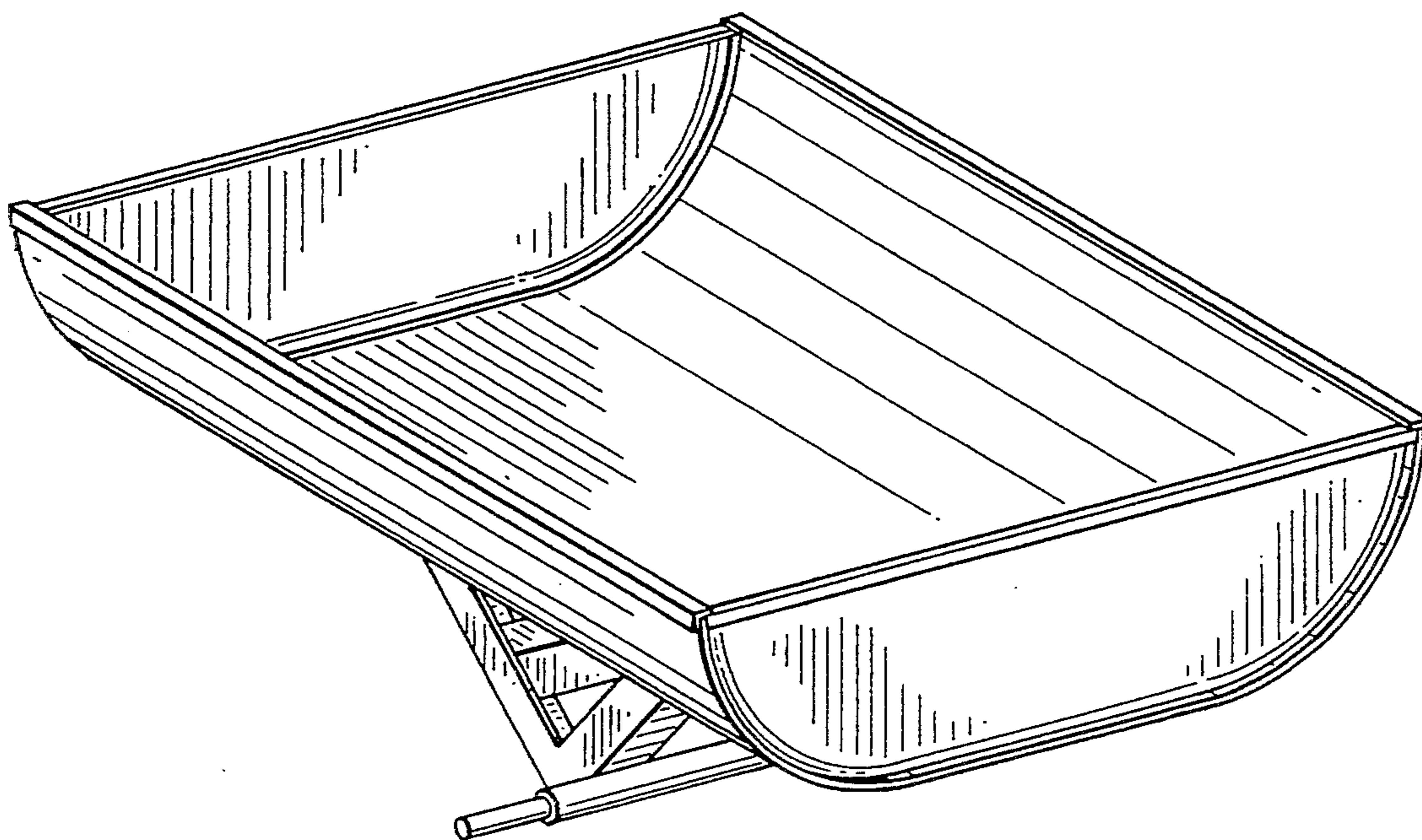

FIG. 7

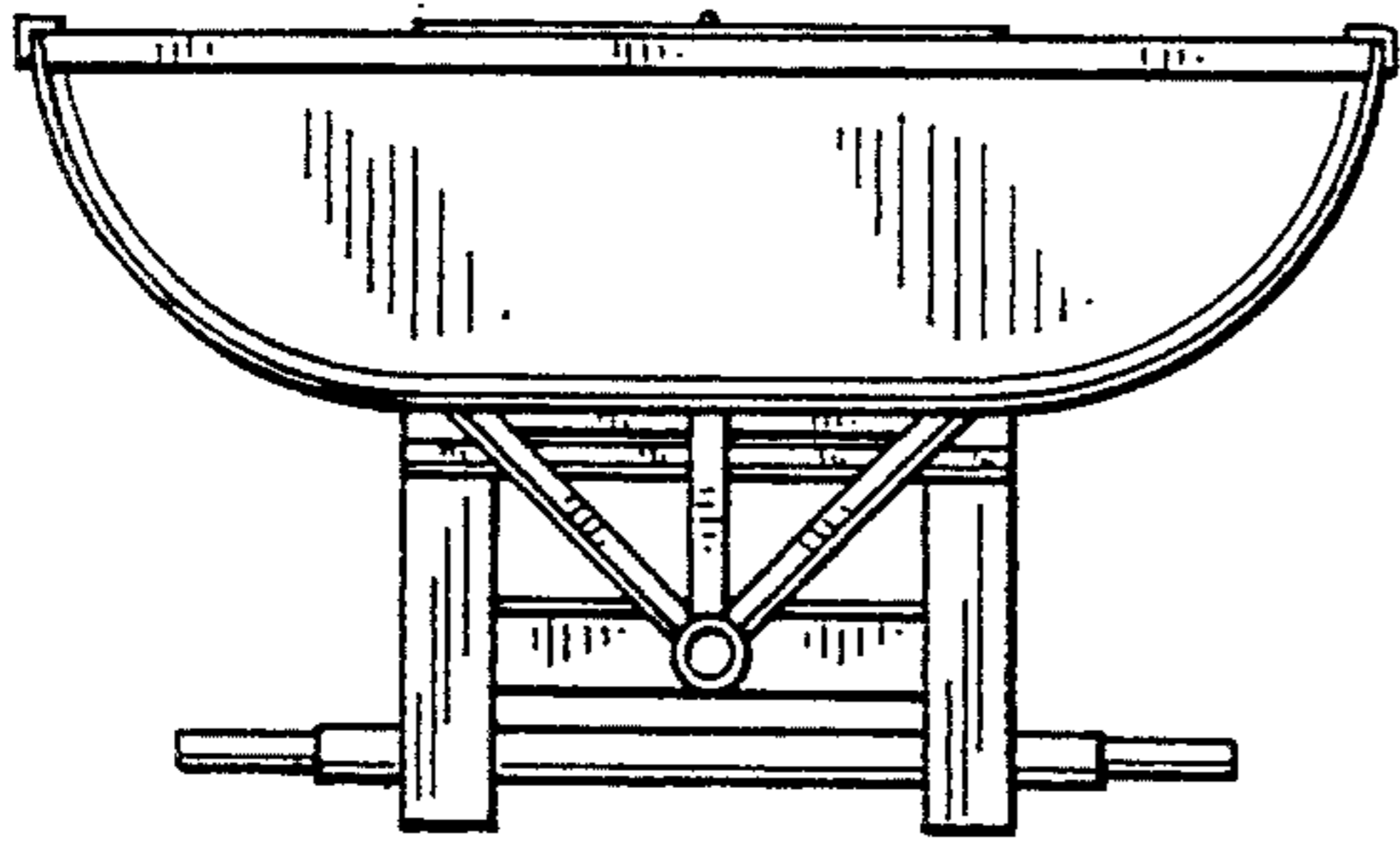

FIG. 8

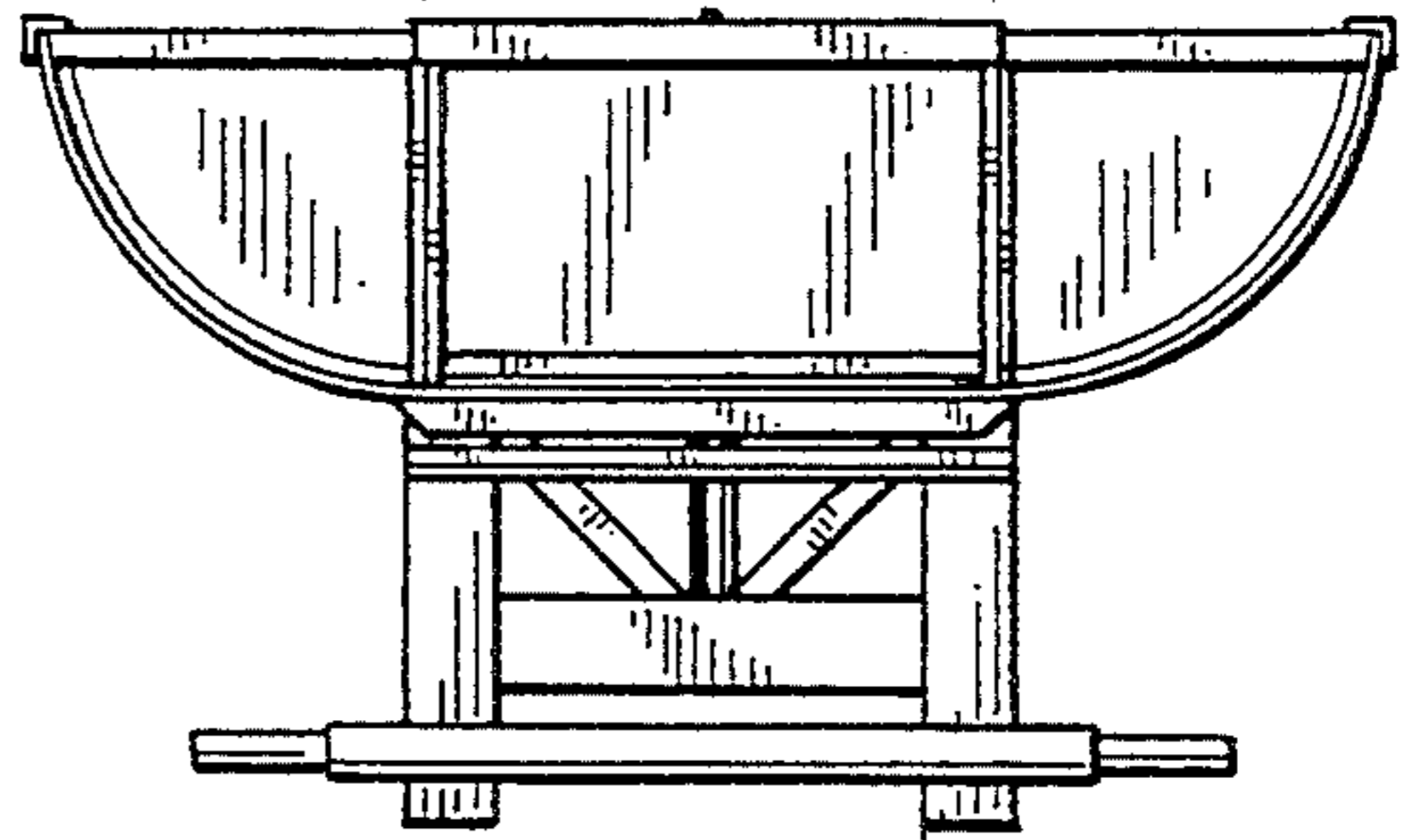

FIG. 9

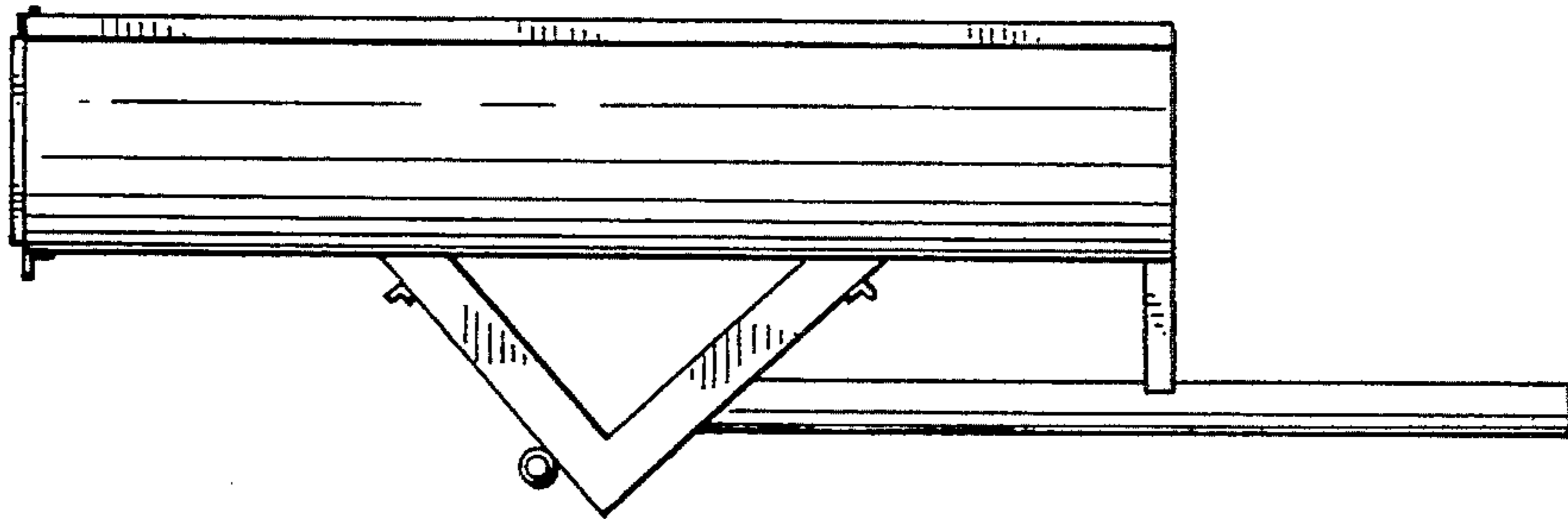

FIG. 10

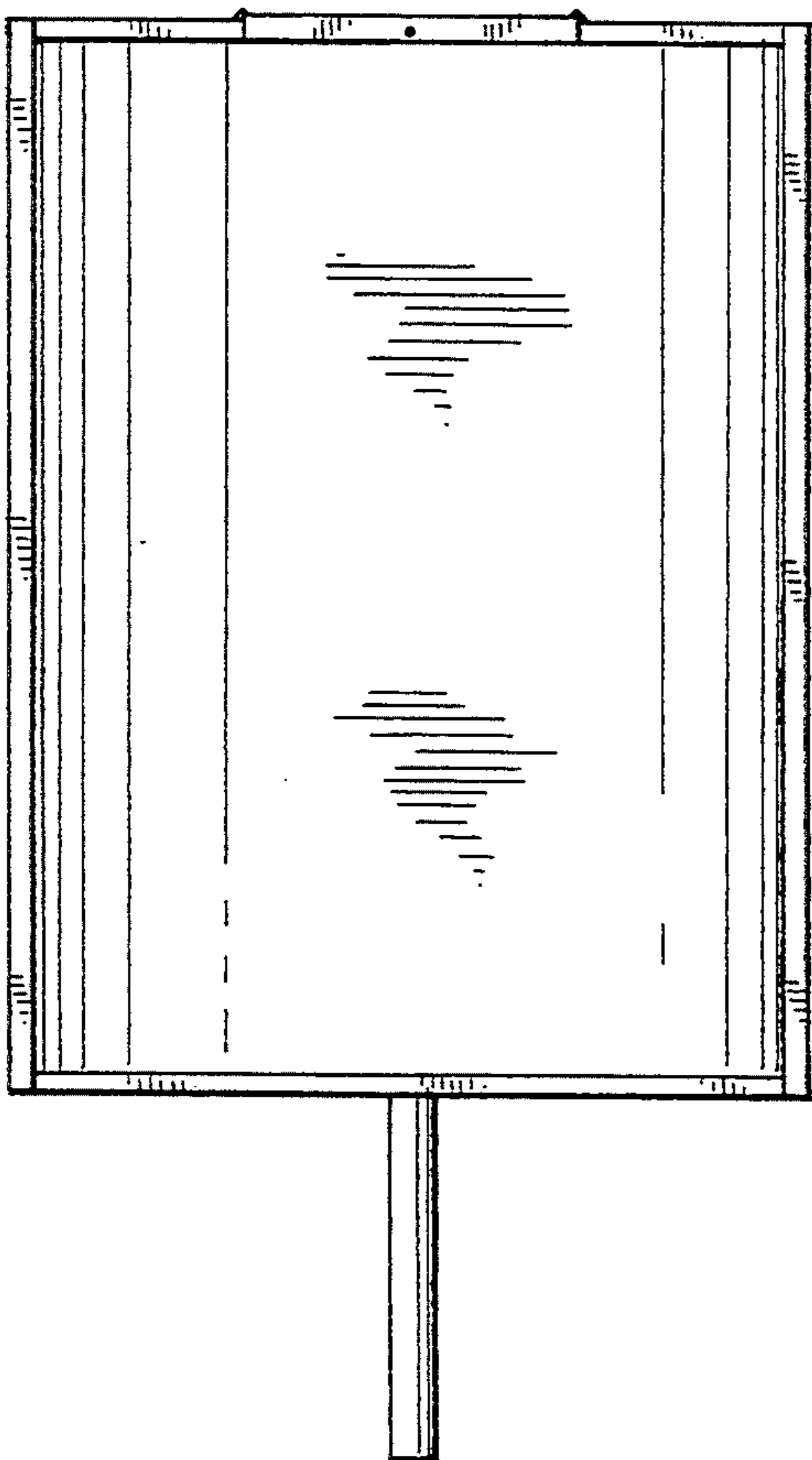

FIG. 11

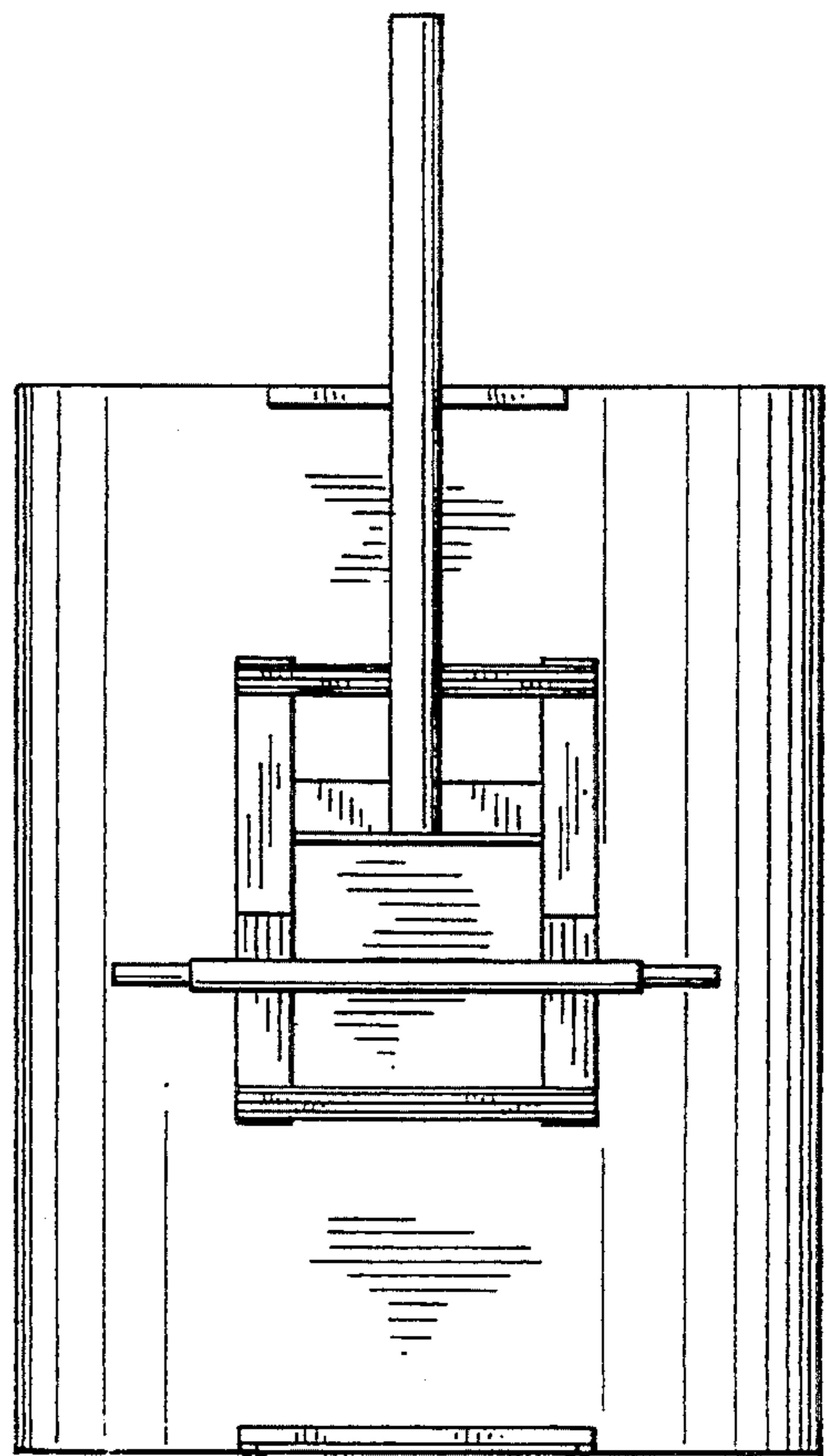

FIG. 12

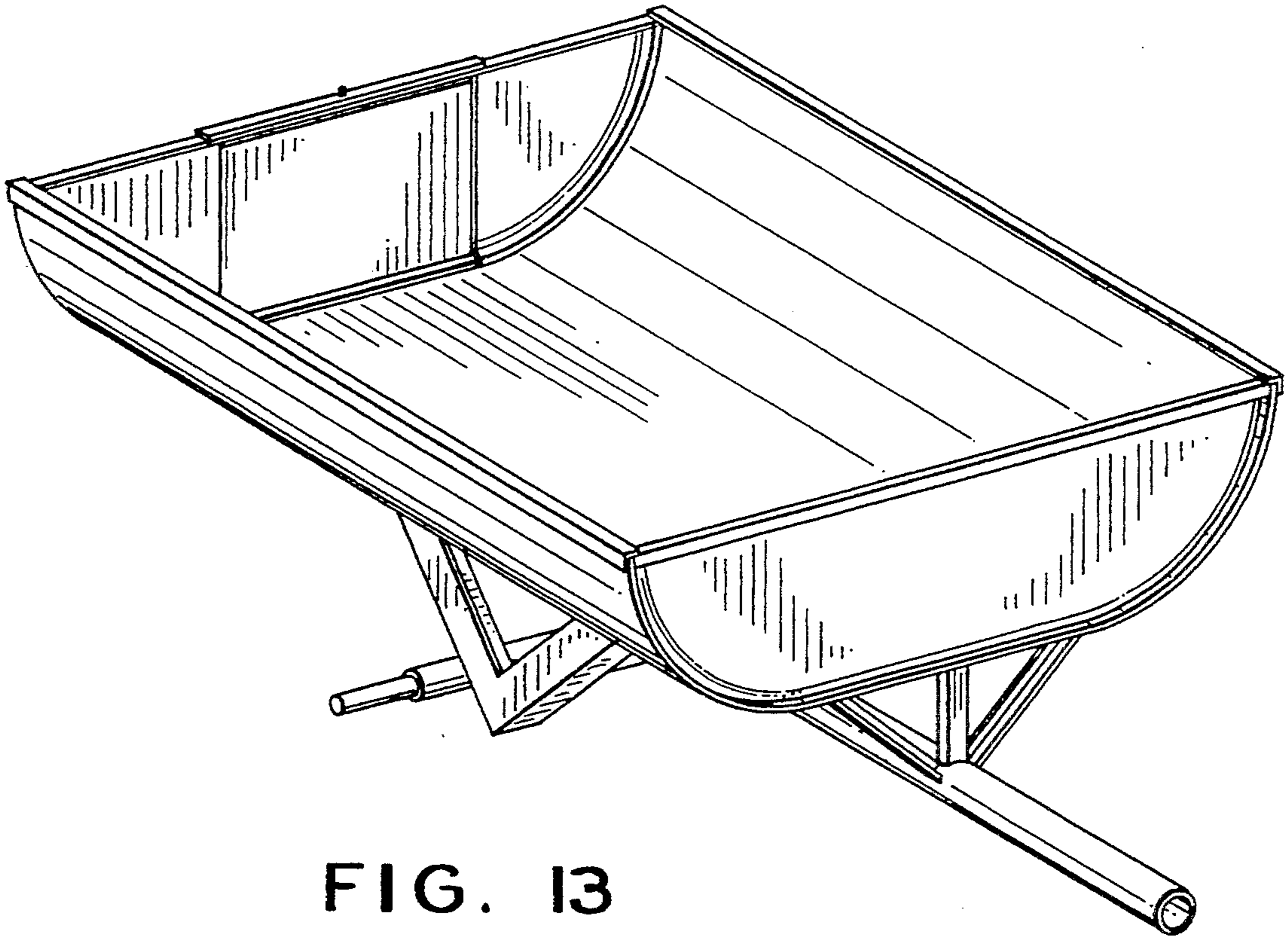

FIG. 13

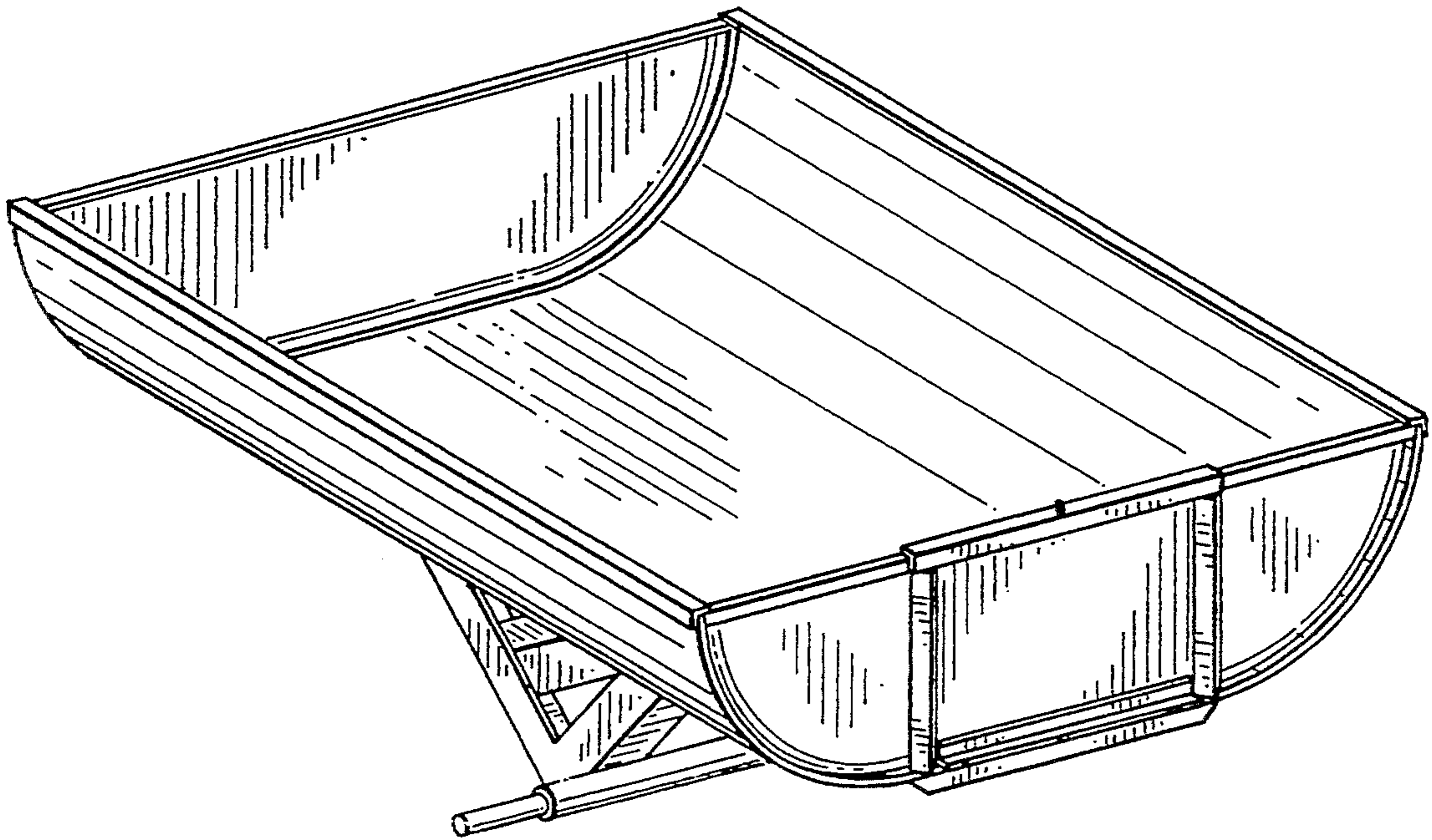

FIG. 14