



US00D360269S

# United States Patent [19] Lake

[11] Patent Number: **Des. 360,269**  
[45] Date of Patent: **\*\* Jul. 11, 1995**

[54] **SOFT LIGHT**  
[75] Inventor: **Ian A. Lake**, Leicestershire, United Kingdom  
[73] Assignee: **Optical & Textile Limited**, New Barnet, United Kingdom  
[\*\*] Term: **14 Years**  
[21] Appl. No.: **18,566**  
[22] Filed: **Feb. 9, 1994**  
[30] **Foreign Application Priority Data**  
Aug. 10, 1993 [GB] United Kingdom ..... 2033060  
[52] U.S. Cl. .... **D26/63**  
[58] Field of Search ..... D26/60, 61, 63, 64, D26/65, 66; 362/269, 271, 272, 275, 418, 419, 427

D. 328,148 7/1992 Waldmann ..... D26/63  
3,018,366 1/1962 O'Keefe ..... D26/63 X  
3,263,069 7/1966 Krucki et al. .... D26/63 X

### OTHER PUBLICATIONS

Kobold DS 575 Light (Prior to Feb. 9, 1994).  
Philips Scoop QGX 542 Light (Prior to Feb. 9, 1994).

*Primary Examiner*—Susan J. Lucas  
*Attorney, Agent, or Firm*—Kerkam, Stowell, Kondracki & Clarke; John C. Kerins

### [57] CLAIM

The ornamental design for a soft light, as shown and described.

### DESCRIPTION

FIG. 1 is a front view of the soft light;  
FIG. 2 is a bottom view of the soft light;  
FIG. 3 is a left elevation of the soft light;  
FIG. 4 is a right elevation of the soft light;  
FIG. 5 is a top view of the soft light; and,  
FIG. 6 is a rear view of the soft light.

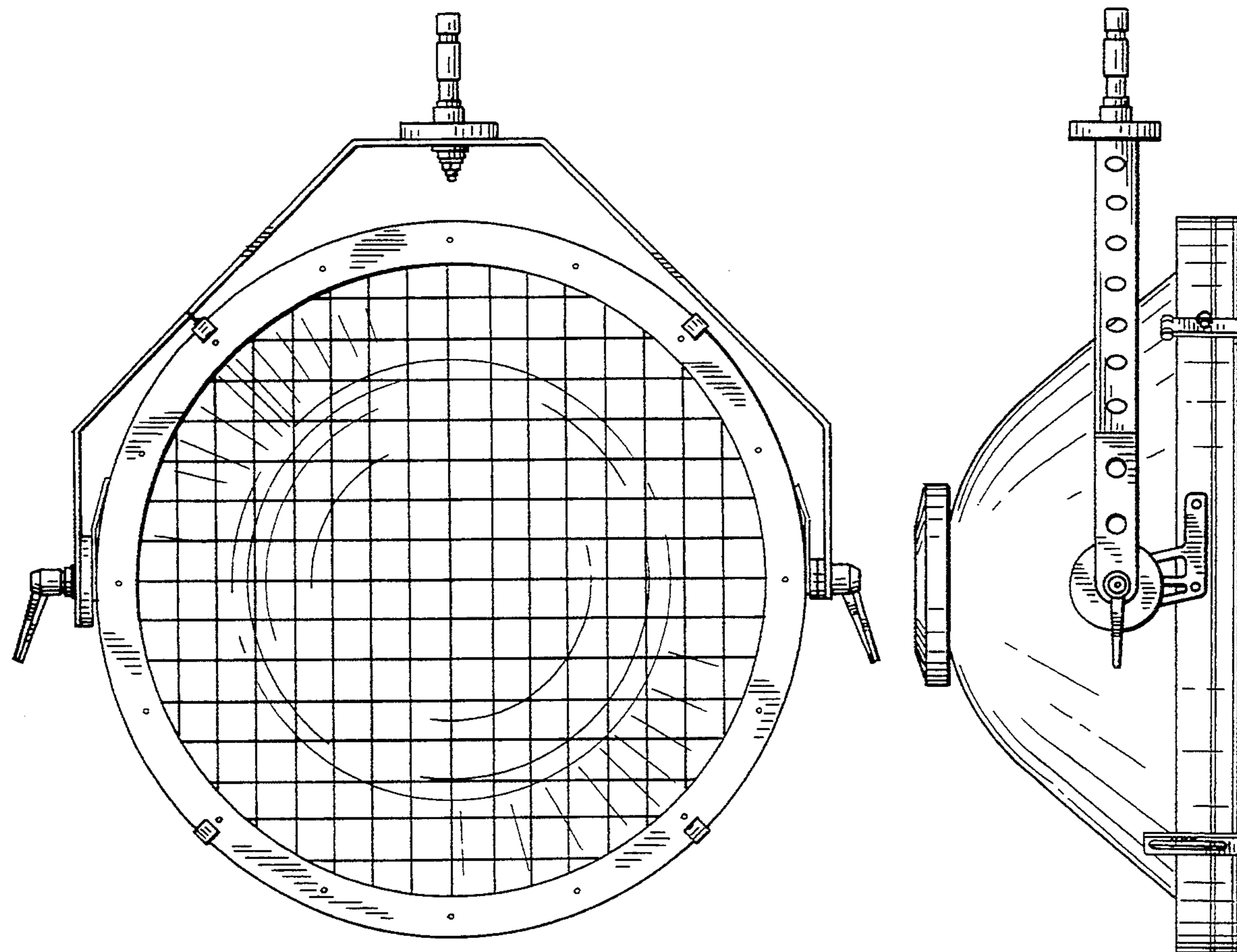

[56] **References Cited**  
**U.S. PATENT DOCUMENTS**  
D. 295,326 4/1988 Dahlgren ..... D26/63

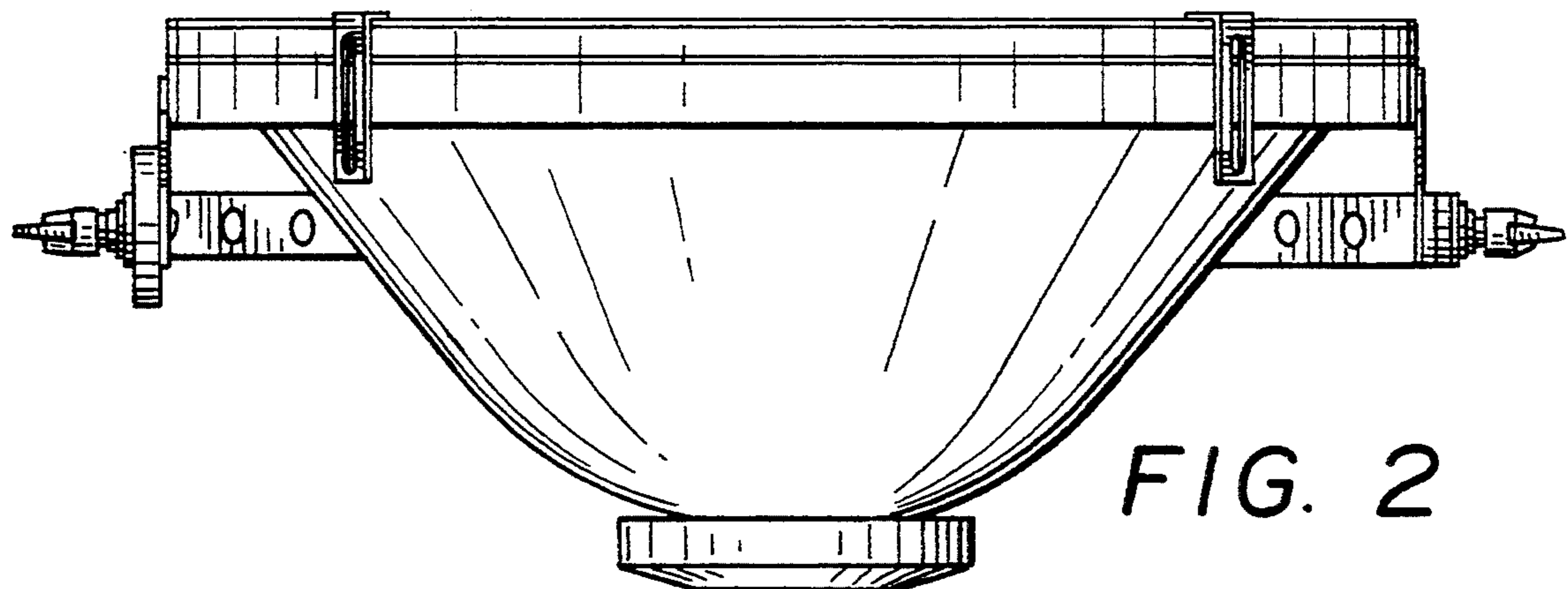
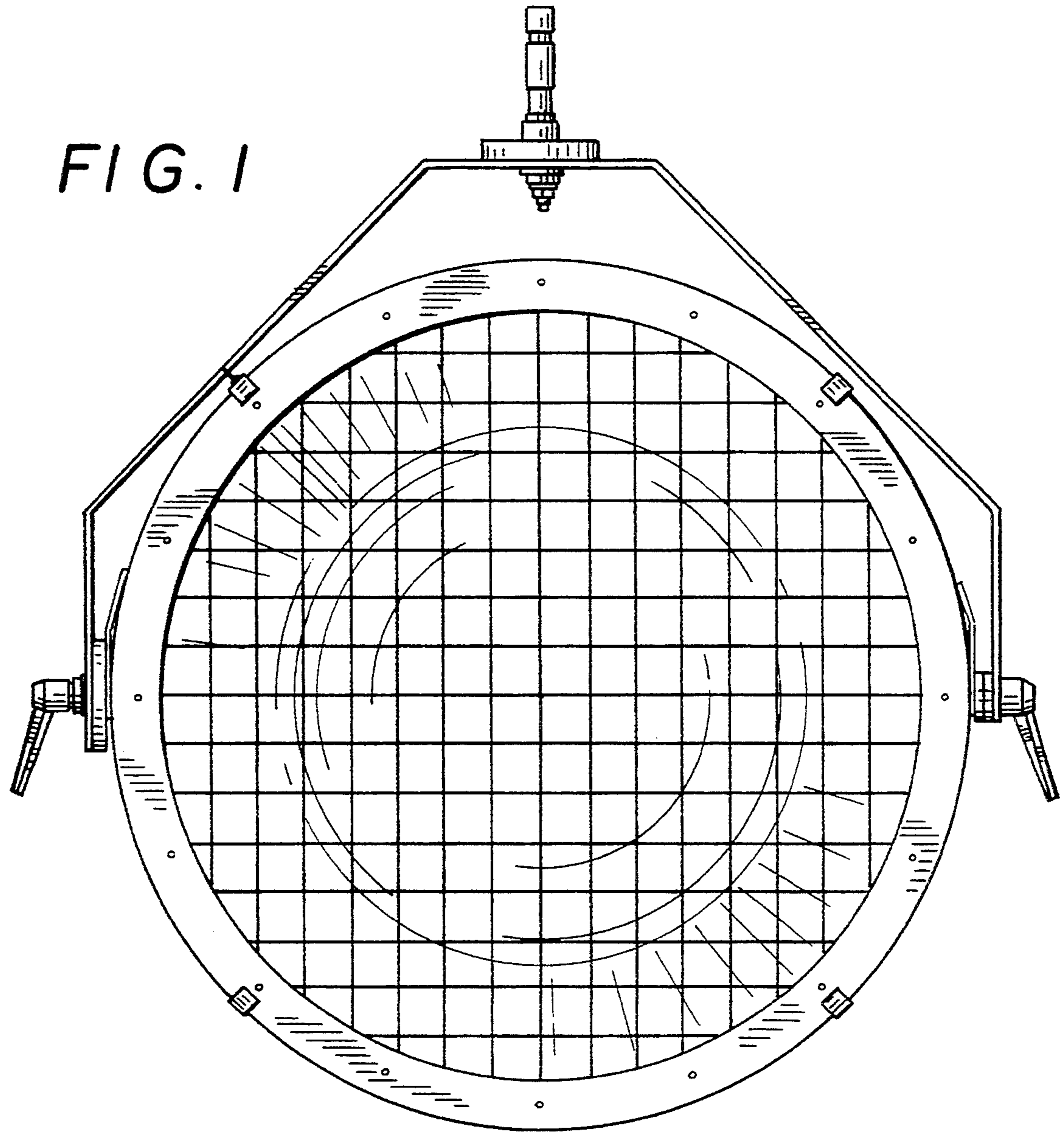

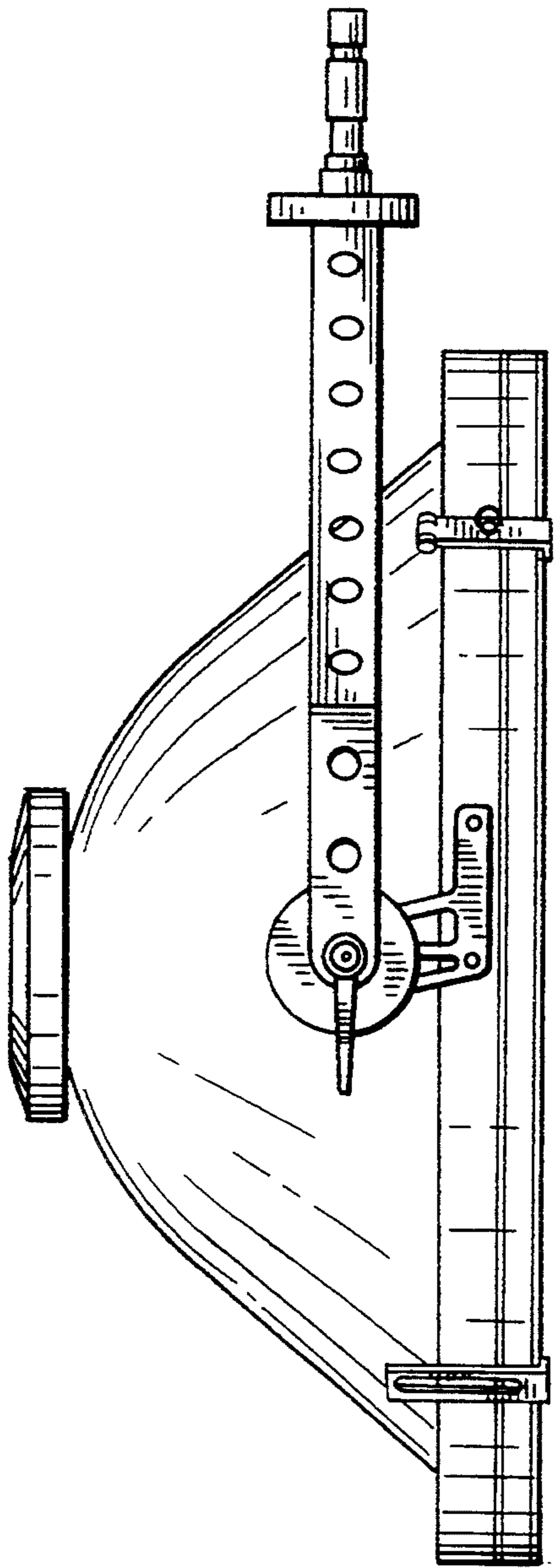

FIG. 3

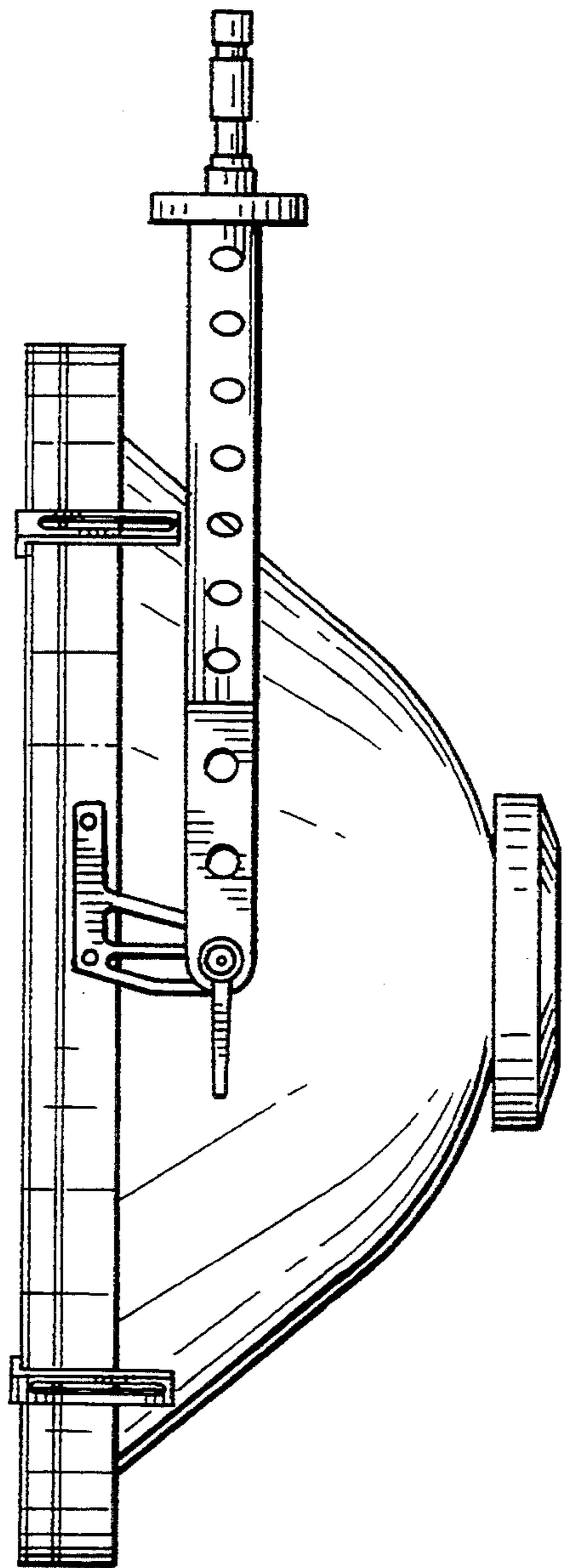

FIG. 4

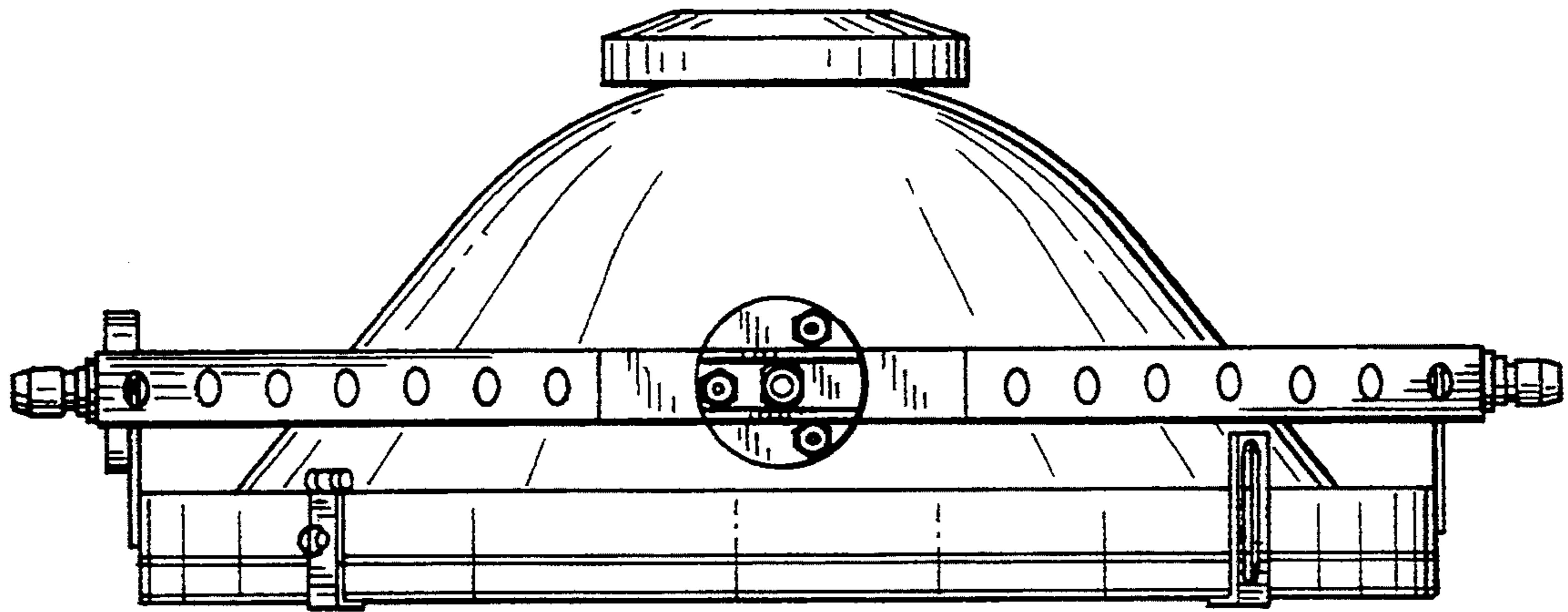

FIG. 5

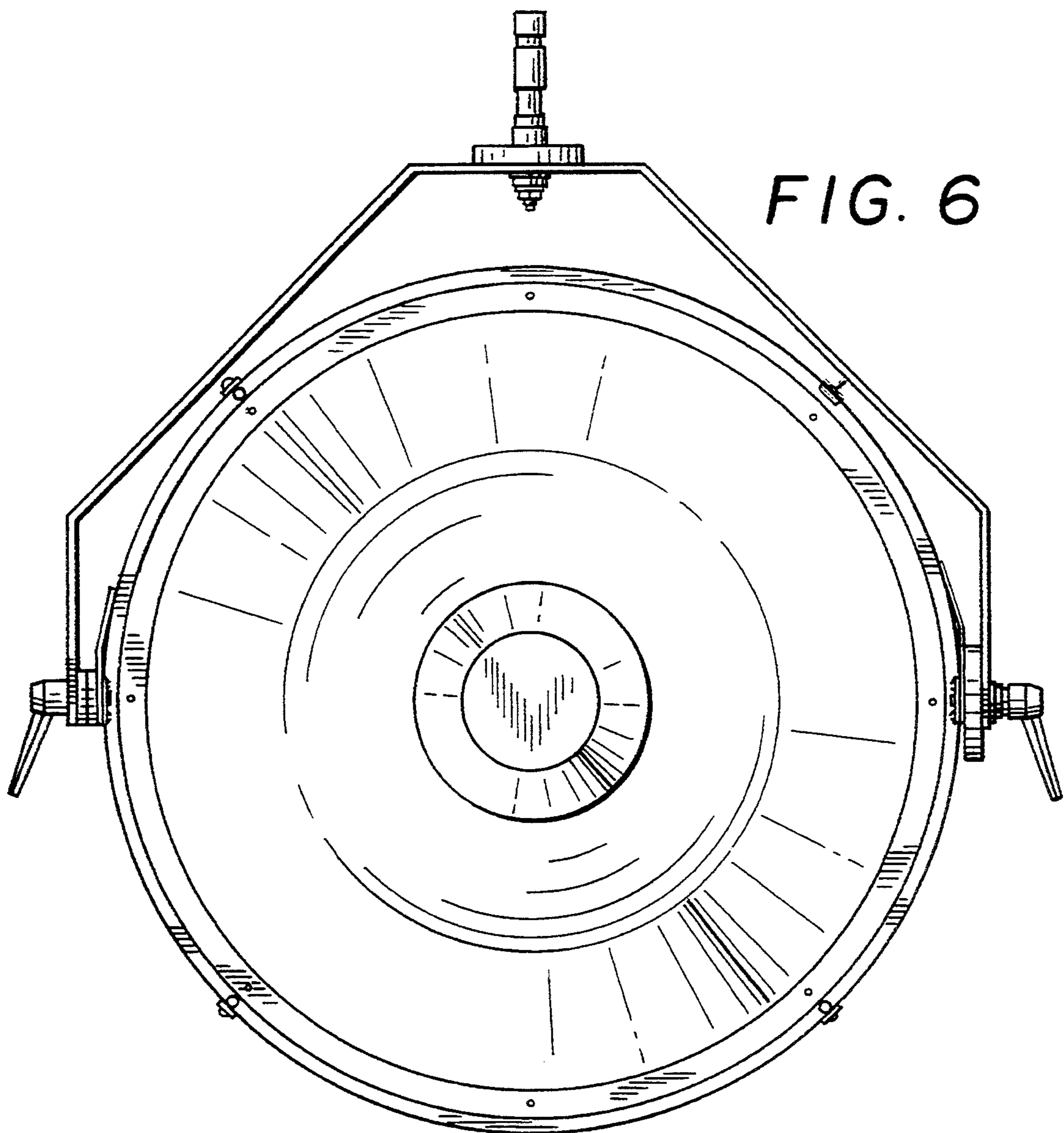

FIG. 6