



US00D360229S

United States Patent [19]

[11] Patent Number: **Des. 360,229**

Caulk

[45] Date of Patent: **** Jul. 11, 1995**

[54] **VEHICLE SIGN**

[76] Inventor: **James W. Caulk**, 1413 Bryant St.,
Leesburg, Fla. 34748

[**] Term: **14 Years**

[21] Appl. No.: **30,932**

[22] Filed: **Nov. 14, 1994**

[52] U.S. Cl. **D20/41**

[58] Field of Search D10/109, 111, 114, 115,
D10/121; D20/10, 17, 39, 40, 41; 40/1, 124,
124.1, 584, 591, 592, 593, 606, 607, 611, 612,
624; 116/63 C, 63 P, 63 R, 173

3,477,161 11/1969 Drexler 116/173
4,533,122 8/1985 Bannister 116/63 P
4,633,215 12/1986 Anders et al. 116/173
4,875,431 10/1989 Dobosz 116/173
4,944,656 7/1990 Feng et al. 116/173

Primary Examiner—A. Hugo Word
Assistant Examiner—Marcus Jackson
Attorney, Agent, or Firm—William M. Hobby, III

[56] **References Cited**

U.S. PATENT DOCUMENTS

2,168,484 8/1939 Zoux 116/173
2,302,524 11/1942 Borregard 116/173
3,016,035 1/1962 Asbury 116/63 P
3,067,717 12/1962 Imparato 116/173
3,117,549 1/1964 Ripepe 116/63 R

[57] **CLAIM**

The ornamental design for vehicle sign, as shown and described.

DESCRIPTION

FIG. 1 is a perspective view of a vehicle sign showing my new design;
FIG. 2 is a bottom plan view;
FIG. 3 is a front elevational view thereof, with the rear being a mirror image;
FIG. 4 is a top plain view; and,
FIG. 5 is a right side elevational view thereof, with the opposite side being a mirror image.

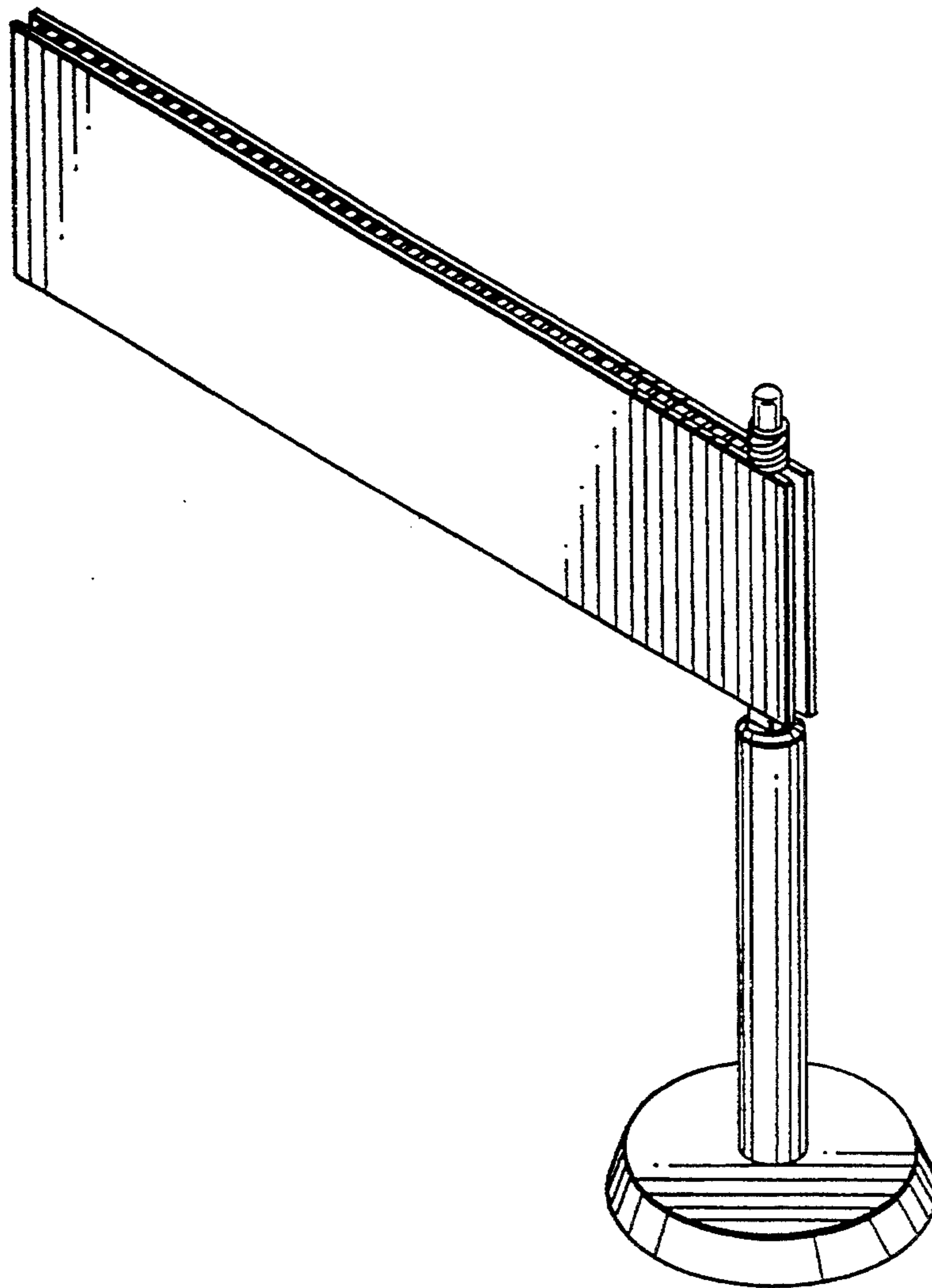

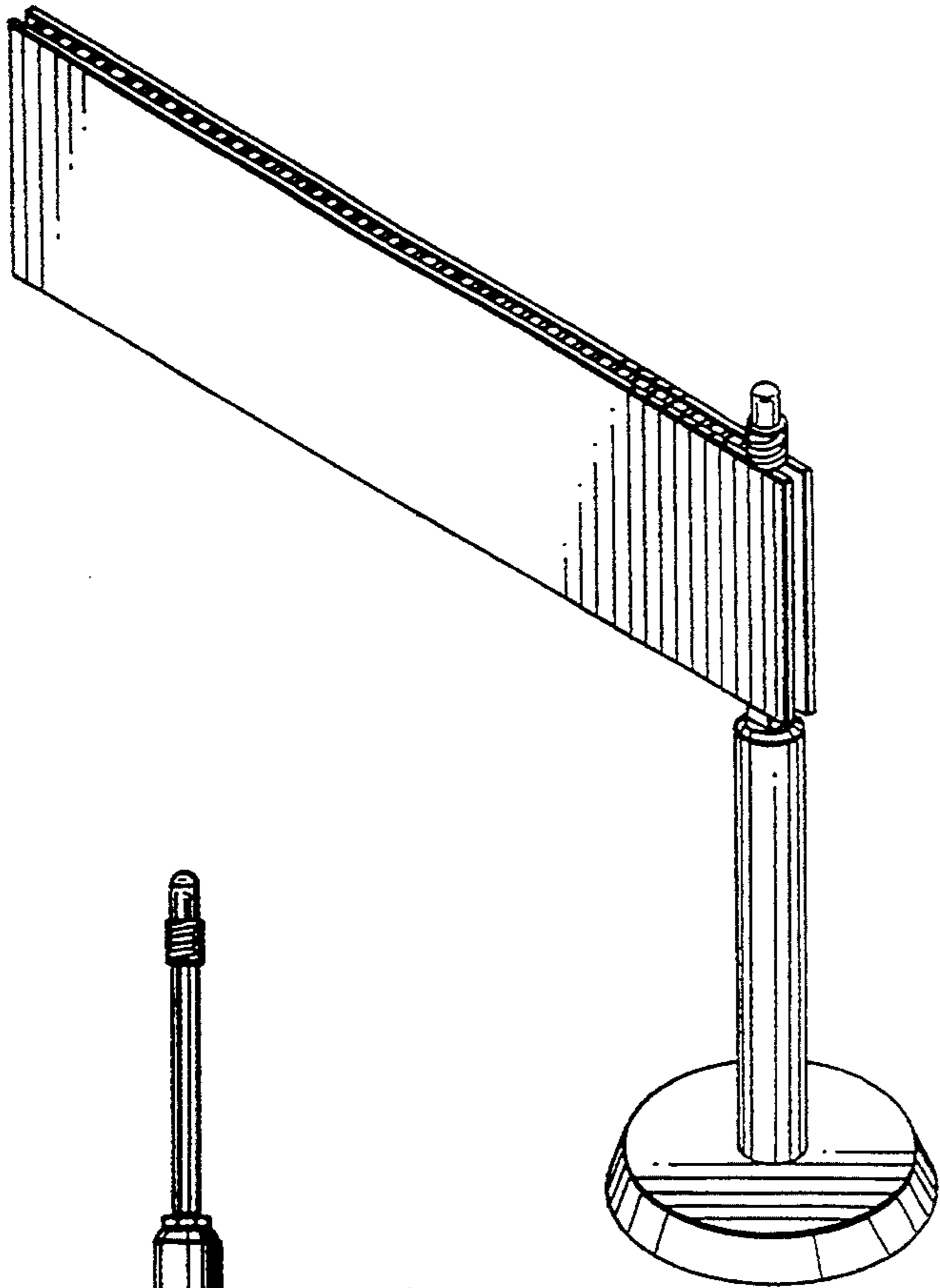

FIG. 1

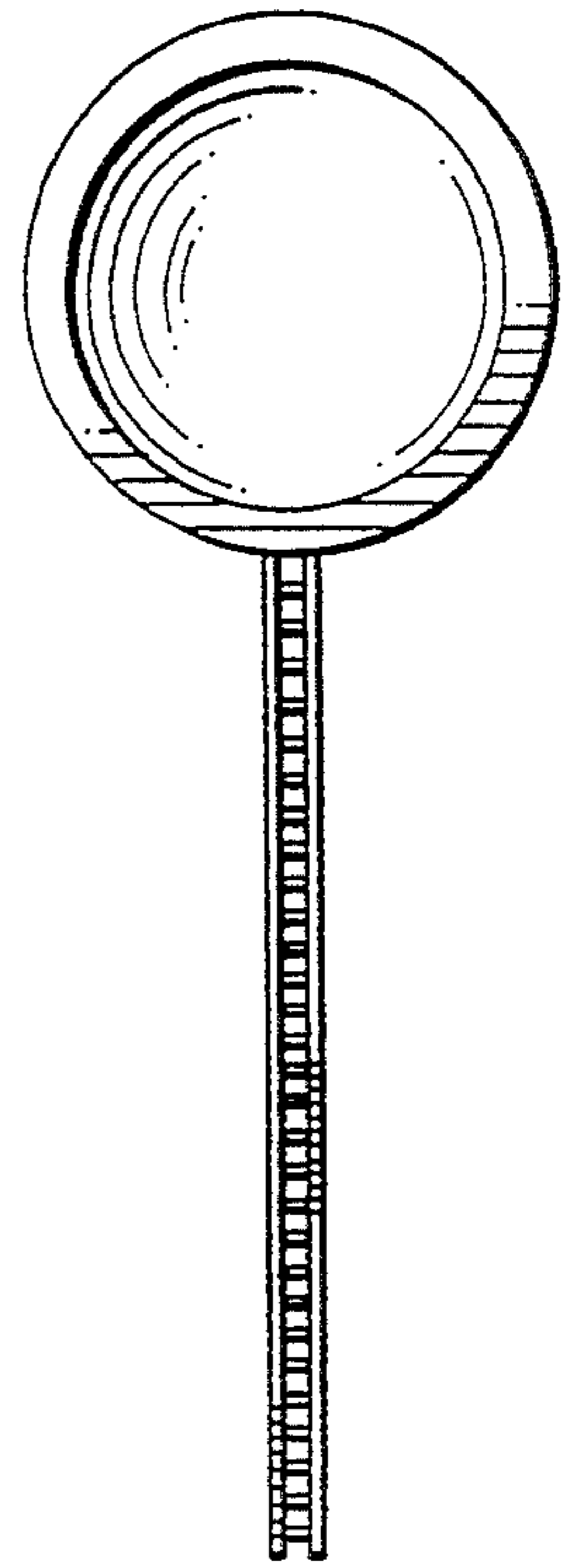

FIG. 2

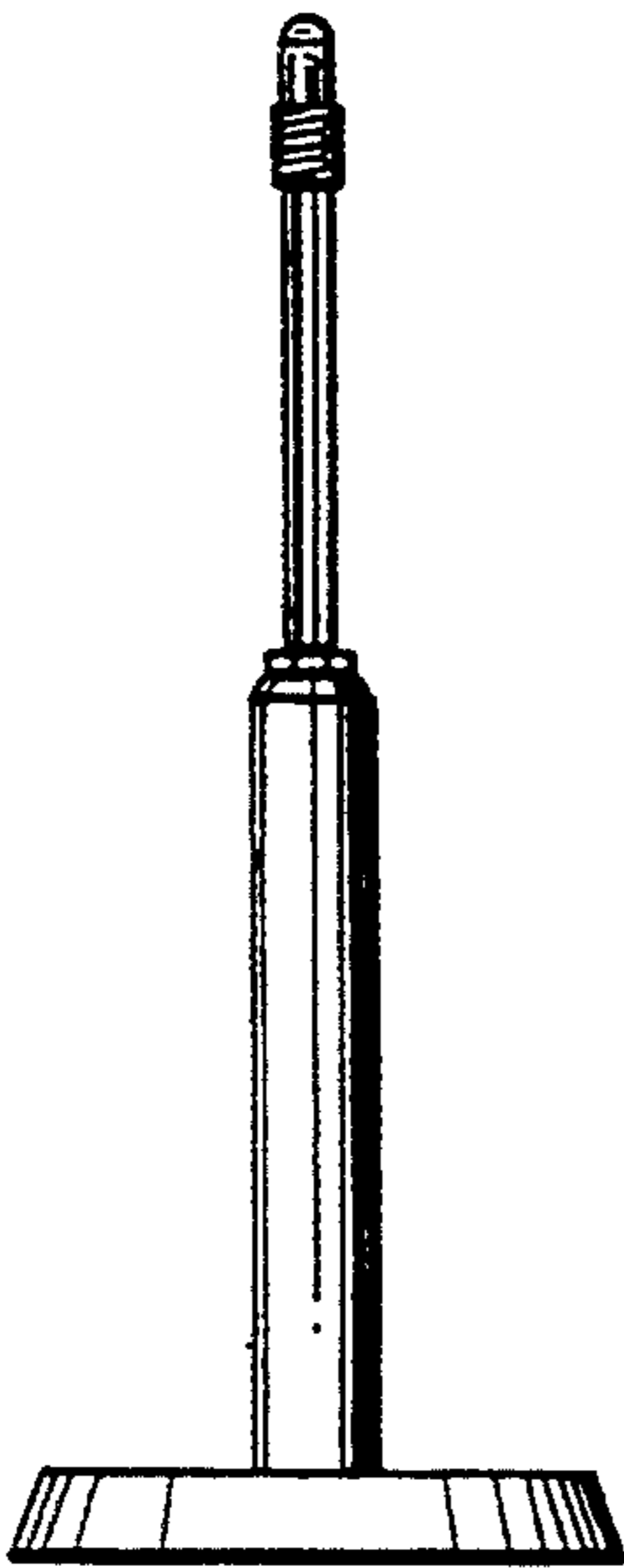

FIG. 3

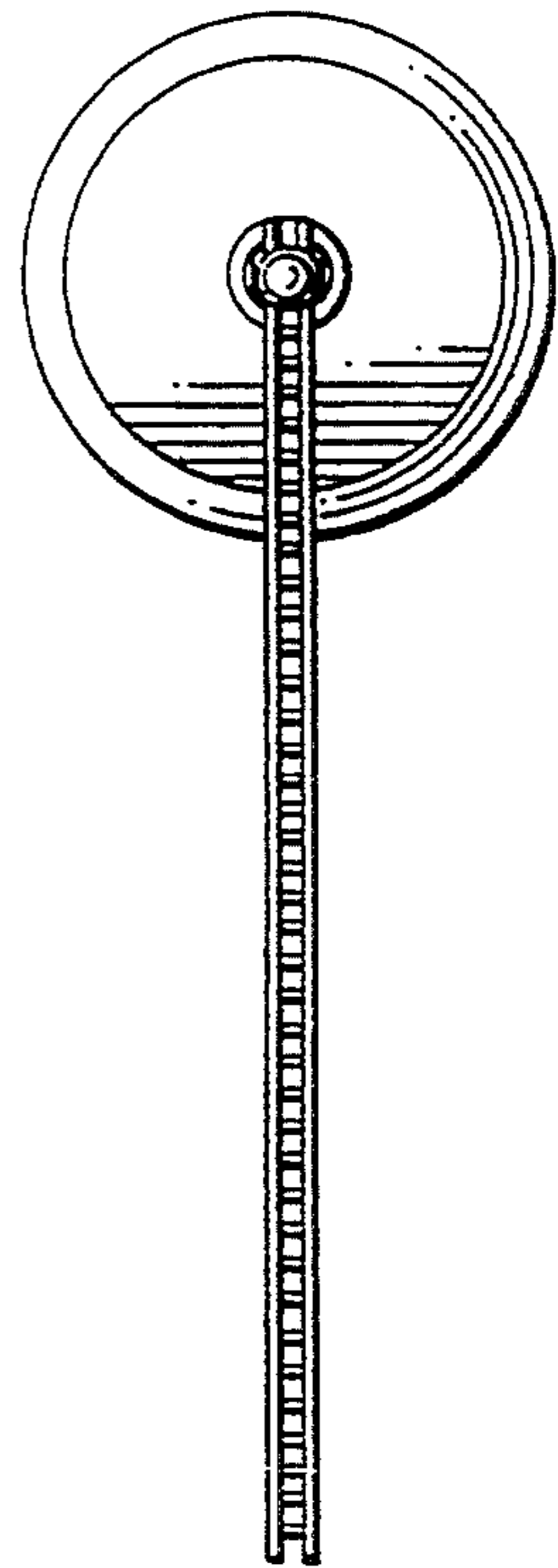

FIG. 4

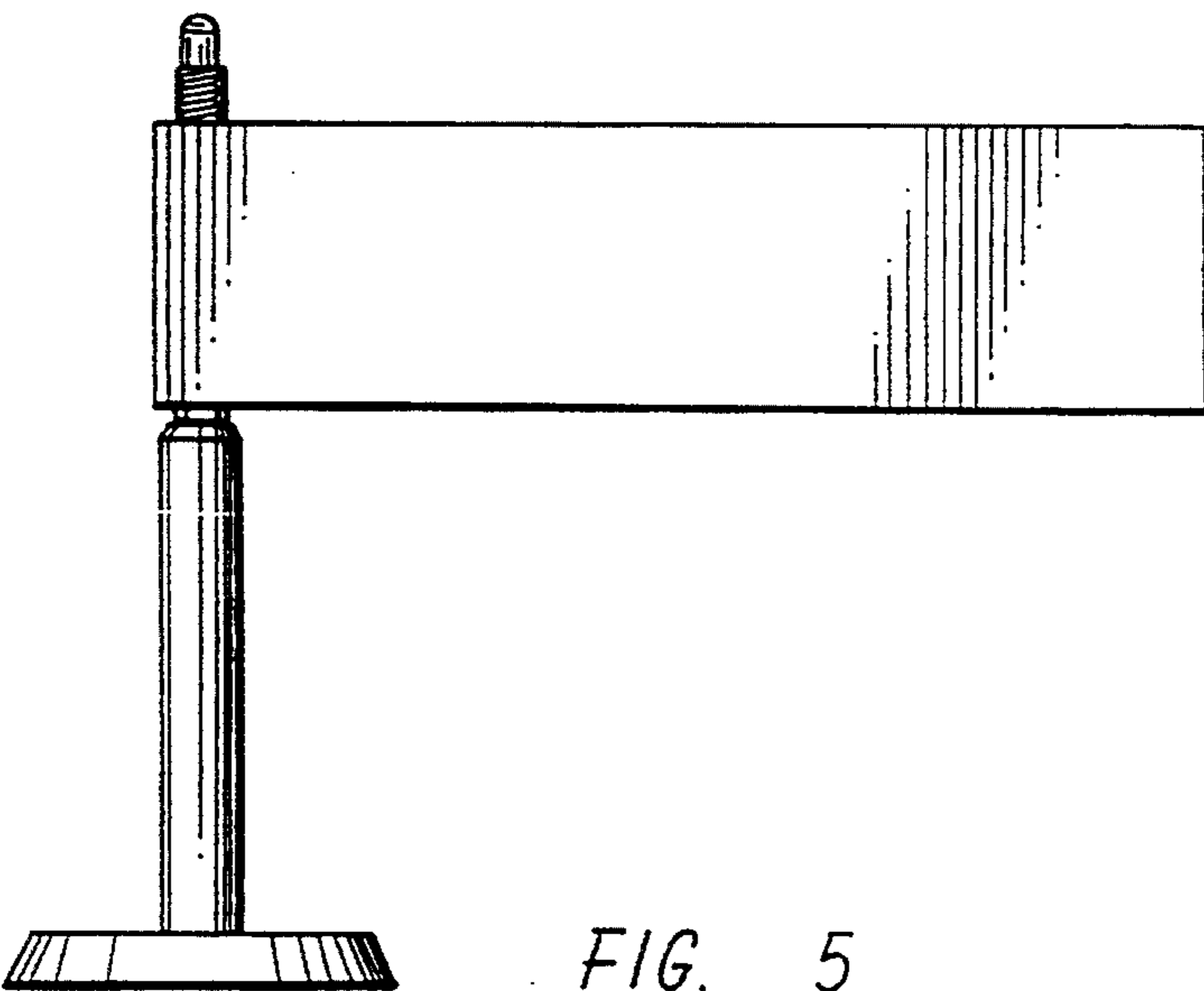

FIG. 5