



US00D360137S

United States Patent [19]
De Baschmakoff

[11] **Patent Number: Des. 360,137**

[45] **Date of Patent: ** Jul. 11, 1995**

[54] **COMBINED BOTTLE AND STOPPER**

[75] Inventor: **Thierry De Baschmakoff**, Paris, France

[73] Assignee: **Partecipazioni Bulgari S.p.A.**, Rome, Italy

[**] Term: **14 Years**

[21] Appl. No.: **18,187**

[22] Filed: **Feb. 1, 1994**

[30] **Foreign Application Priority Data**

Aug. 5, 1993 [IT] Italy RM930/000175

[52] U.S. Cl. **D9/545; D9/571**

[58] Field of Search D9/544, 545, 571, 558, D9/439, 454; 215/1 R, 1 C

[56] **References Cited**

U.S. PATENT DOCUMENTS

- D. 19,182 6/1889 Lowrey .
- D. 49,881 11/1816 Dunnock .
- D. 202,662 10/1965 Williams .
- D. 247,094 1/1978 Britt .
- D. 255,872 7/1980 Shine et al. .
- D. 261,232 10/1981 Grip .
- D. 265,550 7/1982 Young et al. .
- D. 325,347 4/1992 Doering .

FOREIGN PATENT DOCUMENTS

90050 6/1977 Spain .

OTHER PUBLICATIONS

Whitall, Tatum & Co. Catalog, 1907, stoppers #712, #711 and #723.

La Coiffure De Paris publication Perma Artist(e) bottle.

Primary Examiner—Lucy J. Lieberman
Attorney, Agent, or Firm—Ladas & Parry

[57] **CLAIM**

The ornamental design for a combined bottle and stopper, as shown and described.

DESCRIPTION

FIG. 1 is a front elevational view of a combined bottle and stopper showing my new design, the rear elevational view being identical;

FIG. 2 is a right end elevational view thereof, the left end elevational view being identical;

FIG. 3 is a top plan view thereof;

FIG. 4 is a bottom plan view thereof;

FIG. 5 is a perspective view thereof;

FIG. 6 is a front elevational view of the combined bottle and stopper shown in an exploded condition;

FIG. 7 is a right end elevational view of FIG 6, the left end elevational view being identical;

FIG. 8 is a top plan view of the bottle shown without the stopper for clarity of illustration; and,

FIG. 9 is a perspective view of the combined bottle and stopper, shown in an exploded condition.

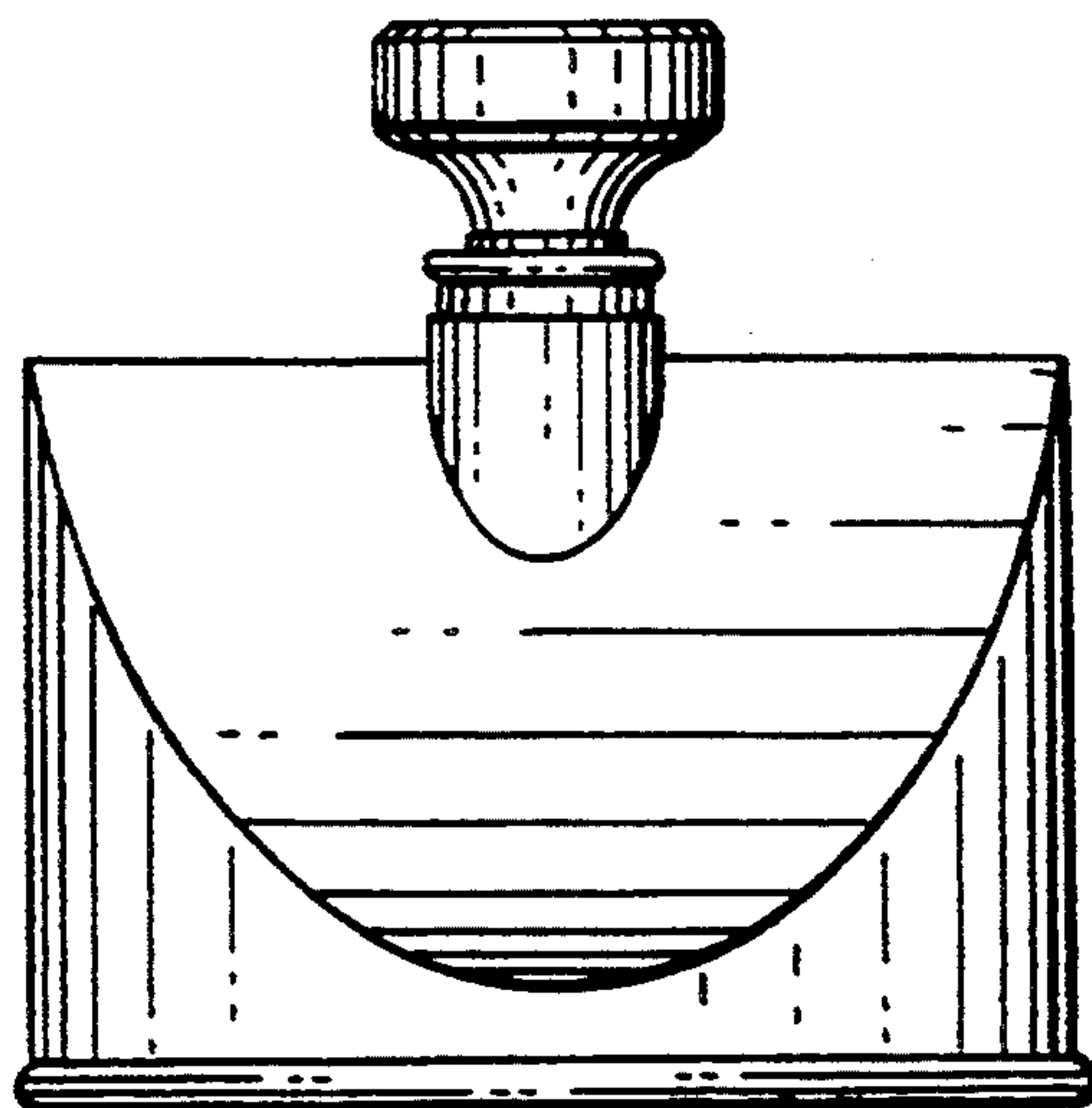

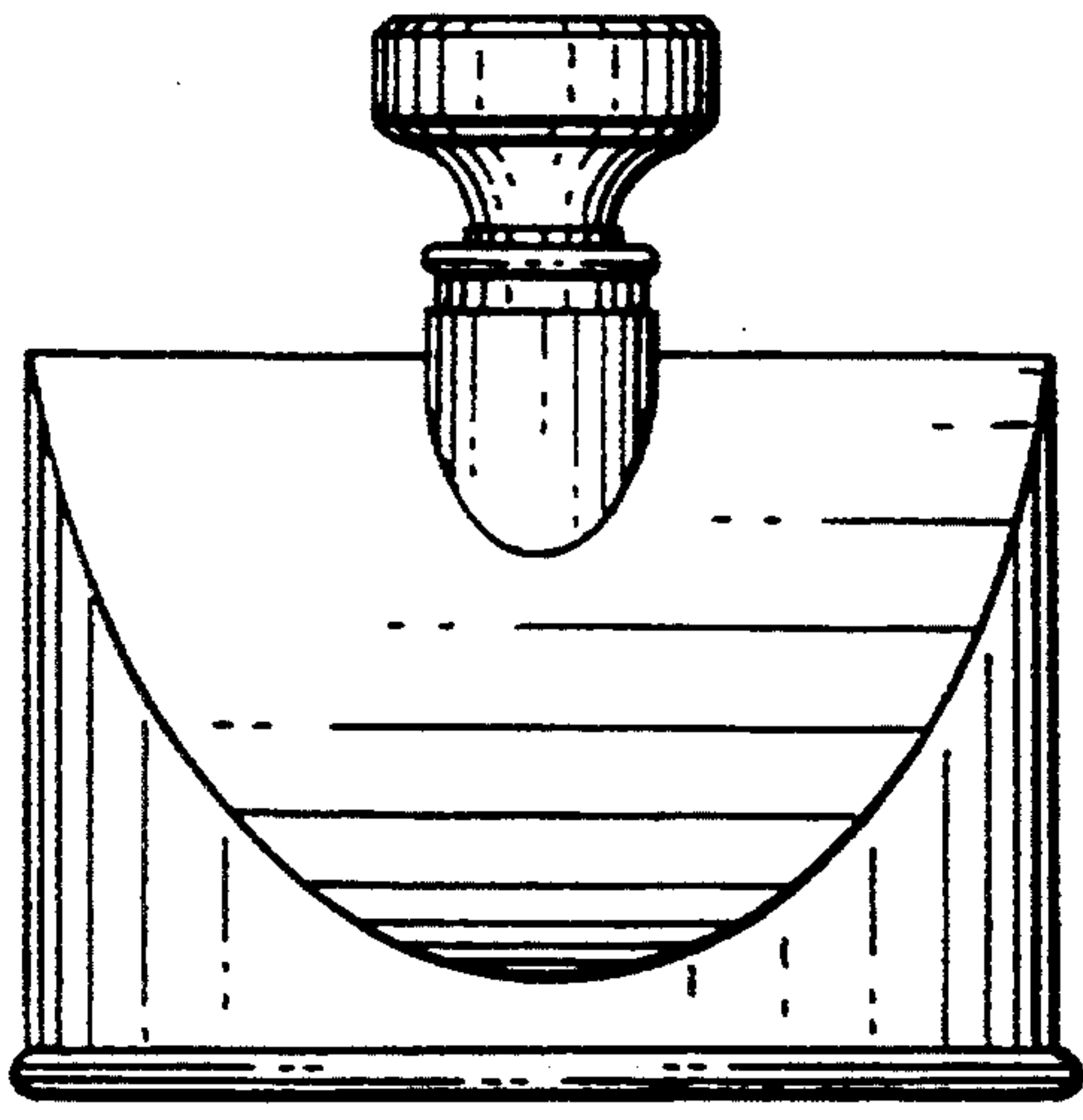

FIG. 1

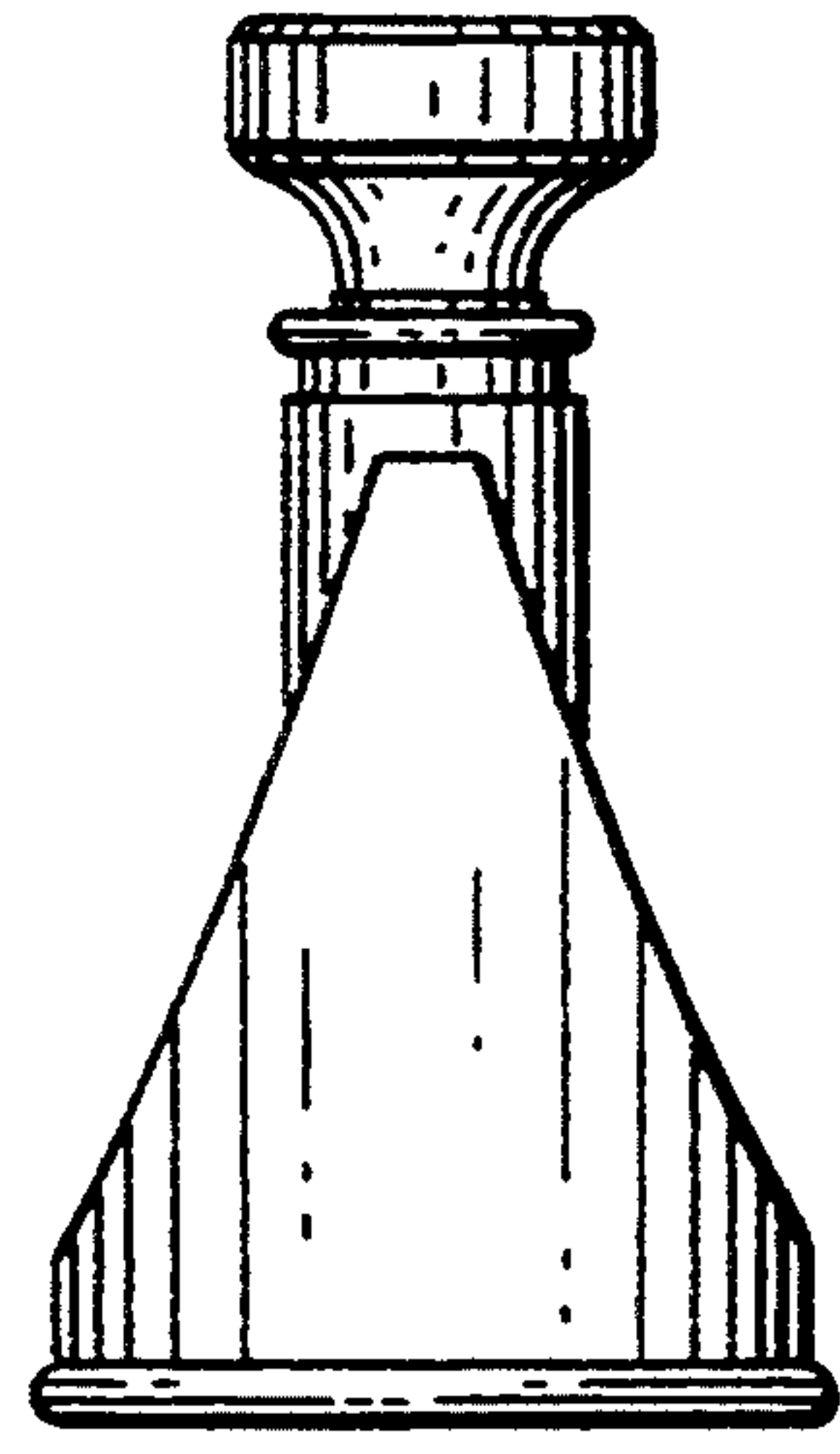

FIG. 2

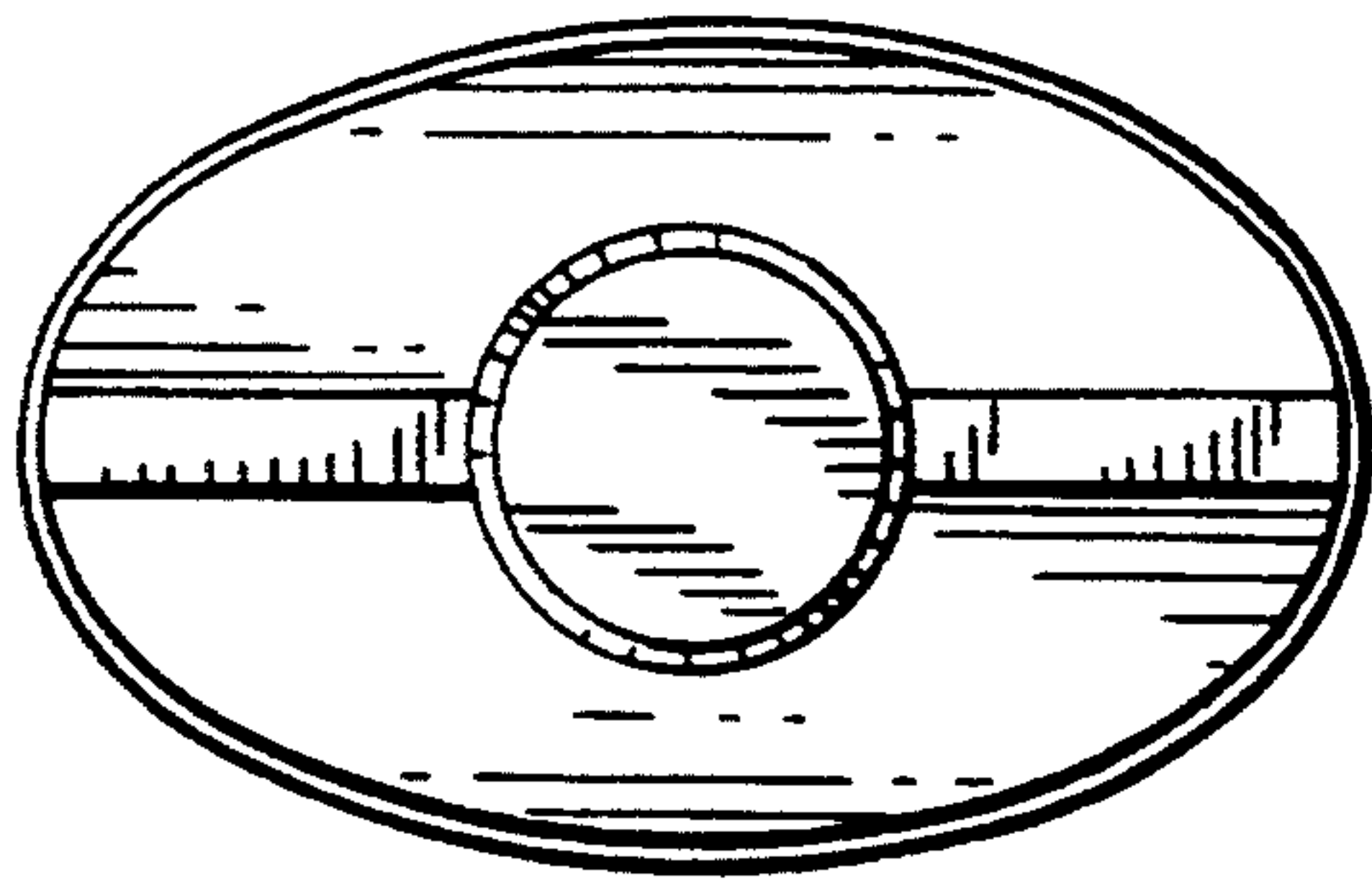

FIG. 3

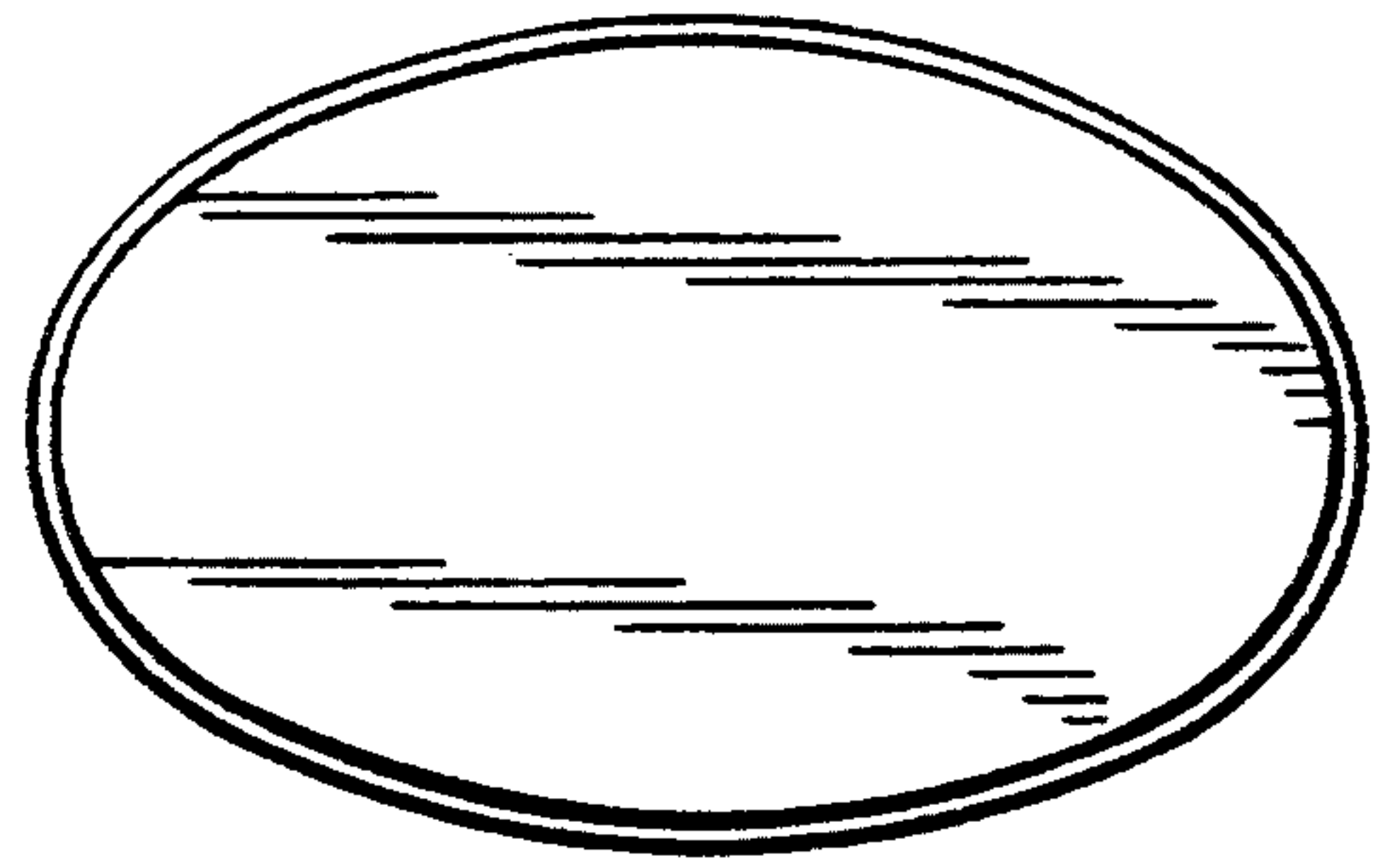

FIG. 4

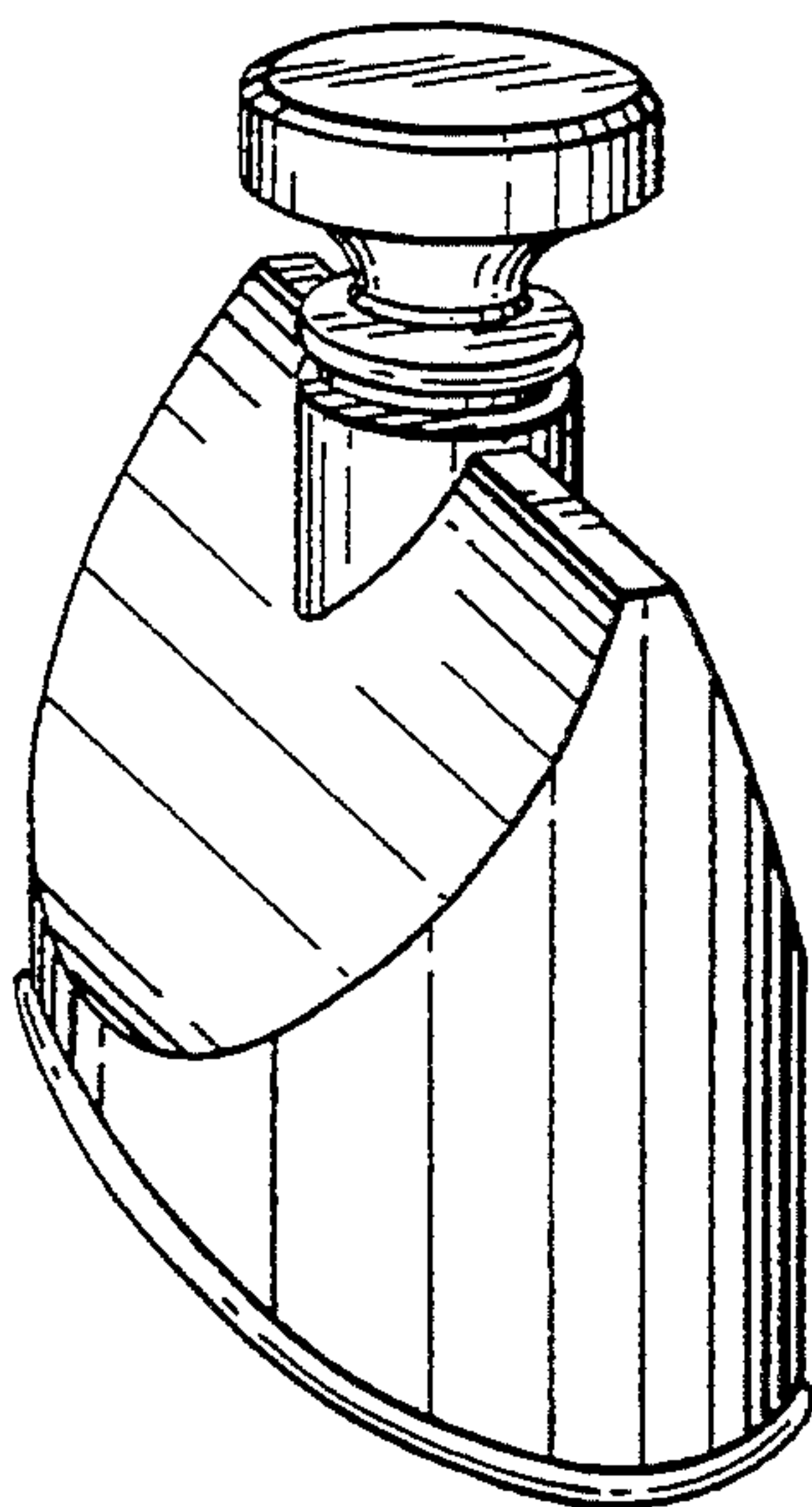

FIG. 5

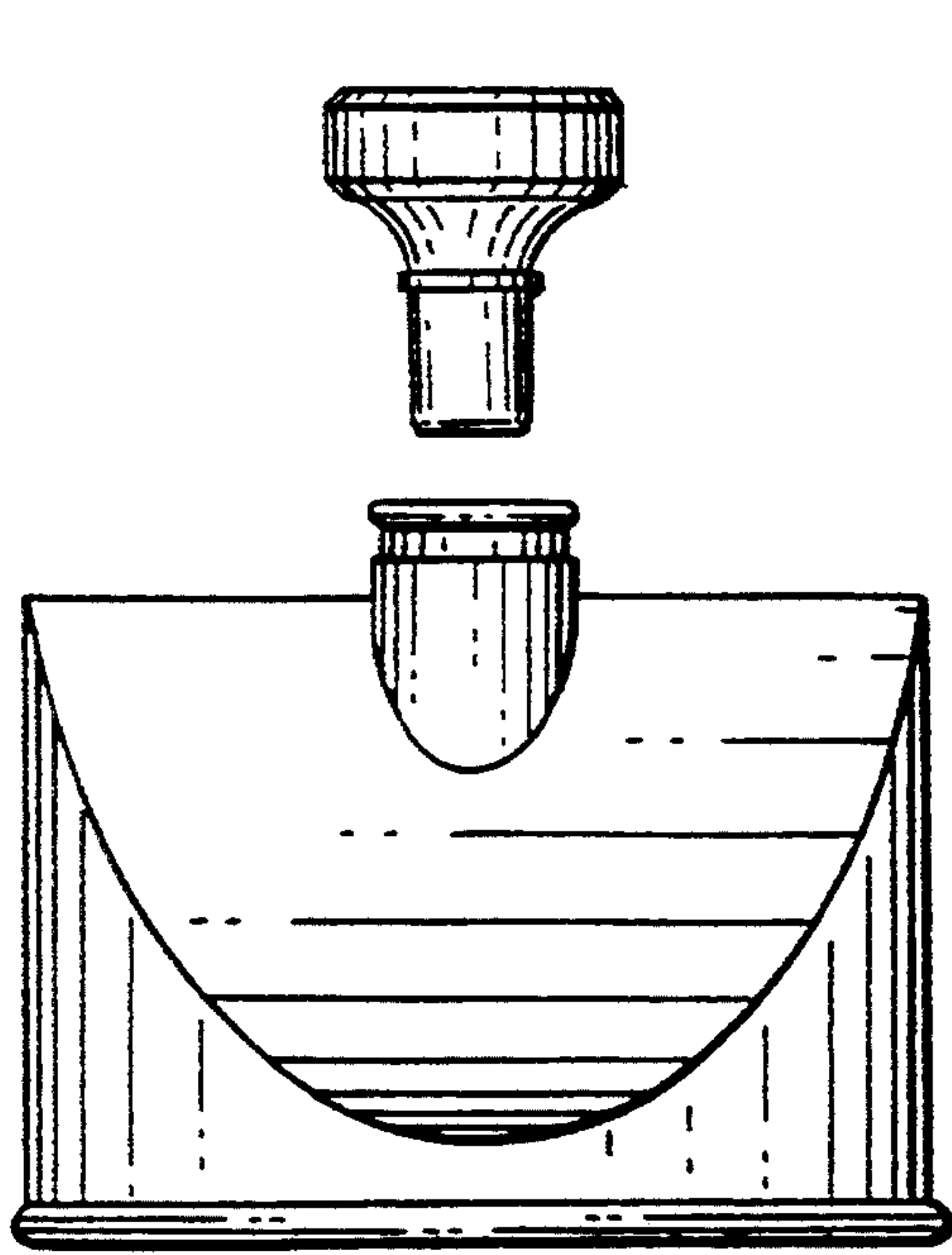

FIG. 6

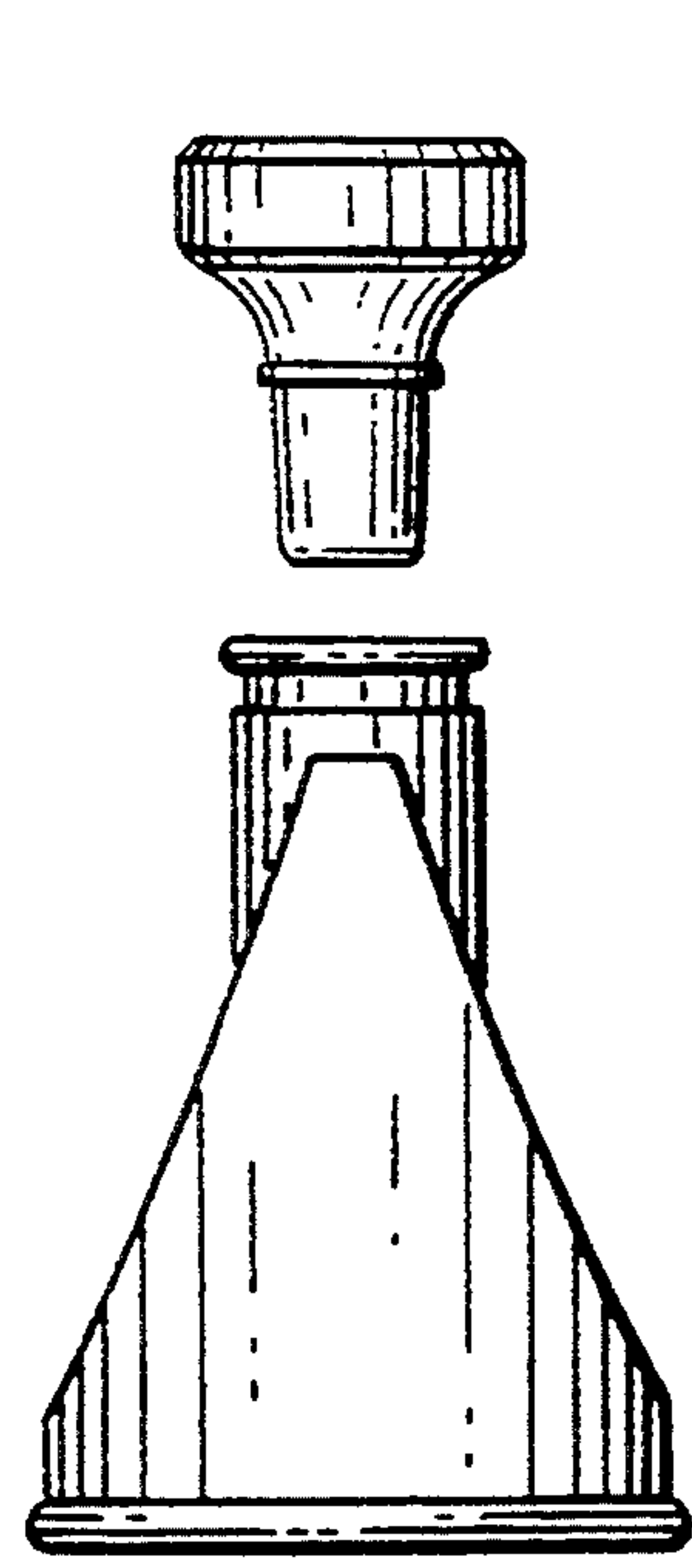

FIG. 7

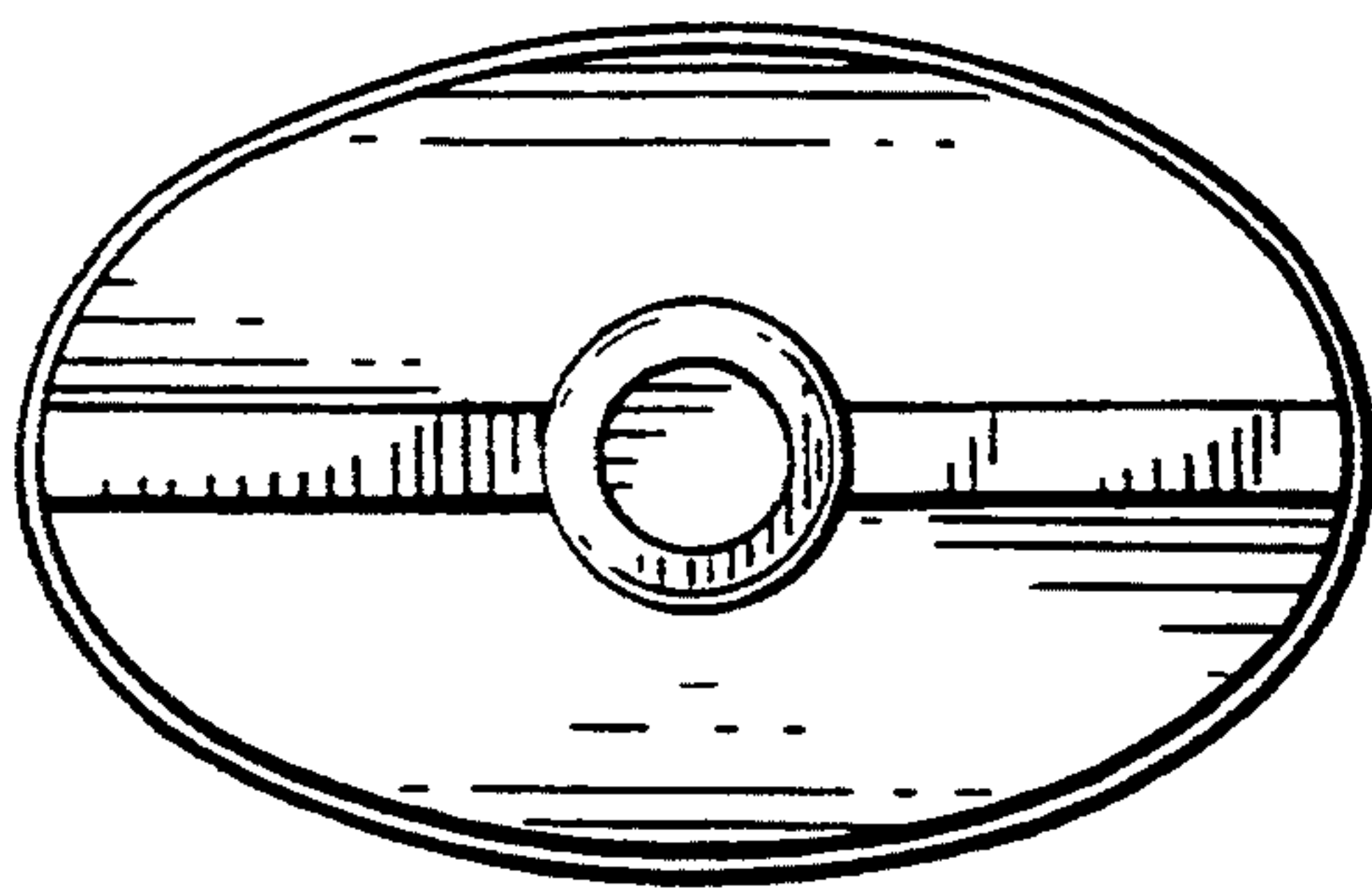

FIG. 8

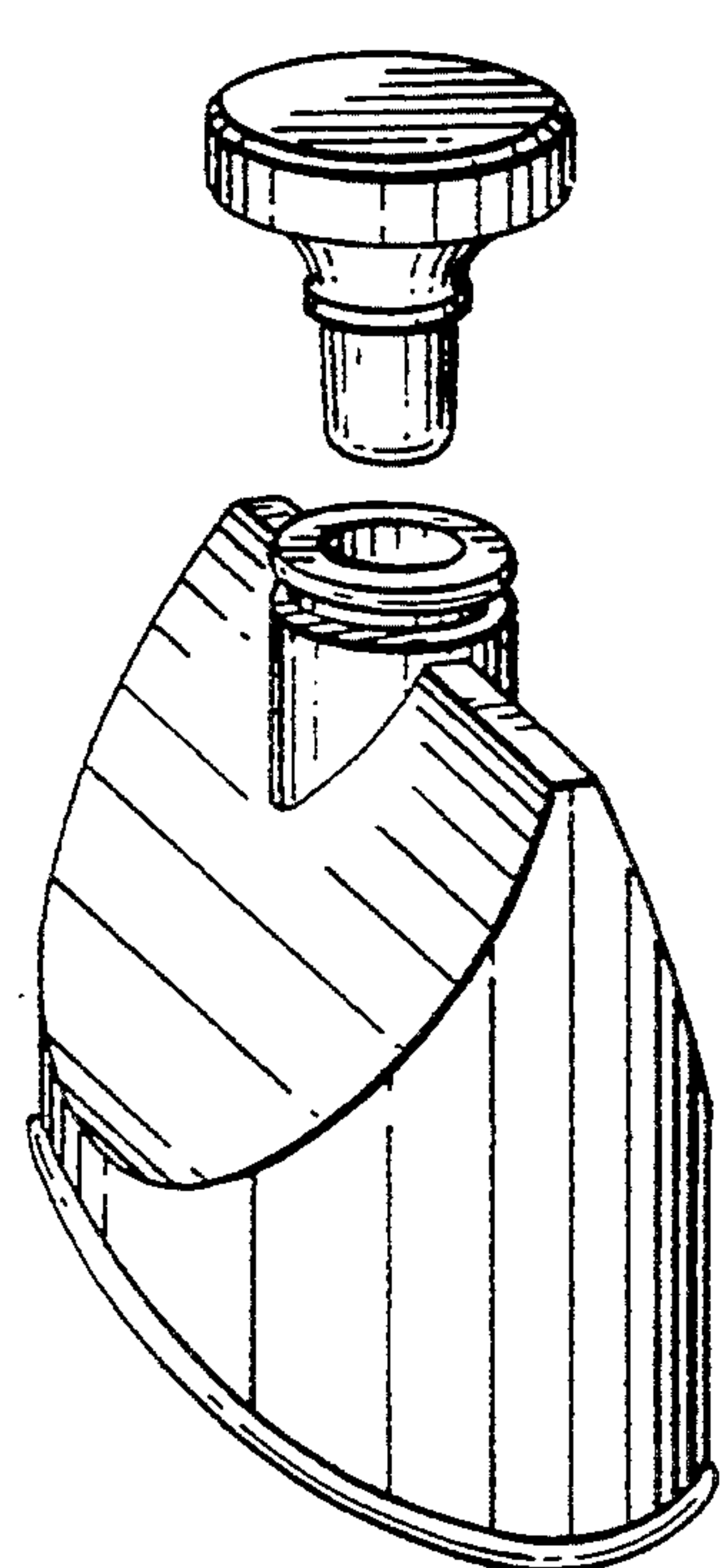

FIG. 9