



US00D359947S

# United States Patent [19] Greene

[11] Patent Number: **Des. 359,947**

[45] Date of Patent: **\*\* Jul. 4, 1995**

[54] **BOAT LIFT CONTROL UNIT**

[75] Inventor: **Richard R. Greene**, Port St. Lucie, Fla.

[73] Assignee: **Hi Tide Sales, Inc.**, Fort Pierce, Fla.

[\*\*] Term: **14 Years**

[21] Appl. No.: **17,457**

[22] Filed: **Jan. 12, 1994**

[52] U.S. Cl. .... **D13/158; D34/35**

[58] Field of Search ..... **D34/28, 35; D13/184, D13/162, 169, 158; 114/44, 48; 405/3, 7; 180/90; 74/DIG. 1, DIG. 2, 480 B; D10/46, 49**

[56] **References Cited**

**U.S. PATENT DOCUMENTS**

D. 312,244	11/1990	Collins et al. ....	D13/184
D. 333,294	2/1993	Dossey .....	D13/169
2,344,441	3/1944	Lorenz .....	180/90

*Primary Examiner*—Brian N. Vinson  
*Assistant Examiner*—Robin V. Taylor

*Attorney, Agent, or Firm*—Sperry, Zoda & Kane

[57] **CLAIM**

The ornamental design for a boat lift control unit, as shown and described.

**DESCRIPTION**

FIG. 1 is a top, front and left side perspective view of a boat lift control unit showing my new design. The cables are shown broken-away to indicate indeterminate length;

FIG. 2 is a front view thereof;

FIG. 3 is a rear view thereof;

FIG. 4 is a left side view thereof;

FIG. 5 is a right side view thereof;

FIG. 6 is a top plan view thereof;

FIG. 7 is a bottom view thereof;

FIG. 8 is a top, front and left side view thereof in open position;

FIG. 9 is a front view thereof;

FIG. 10 is a rear view thereof;

FIG. 11 is a left side view thereof; and,

FIG. 12 is a top plan view thereof.

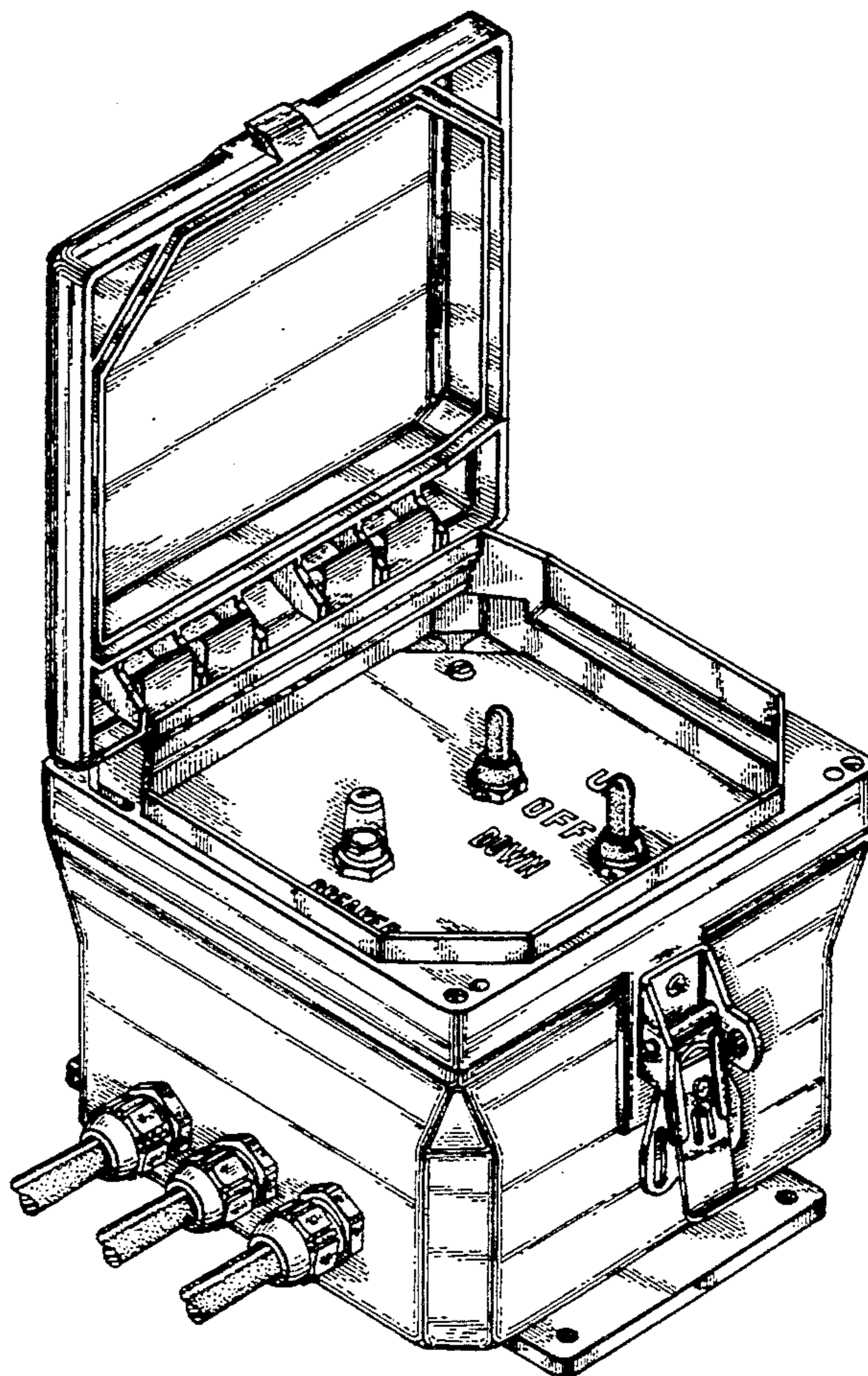
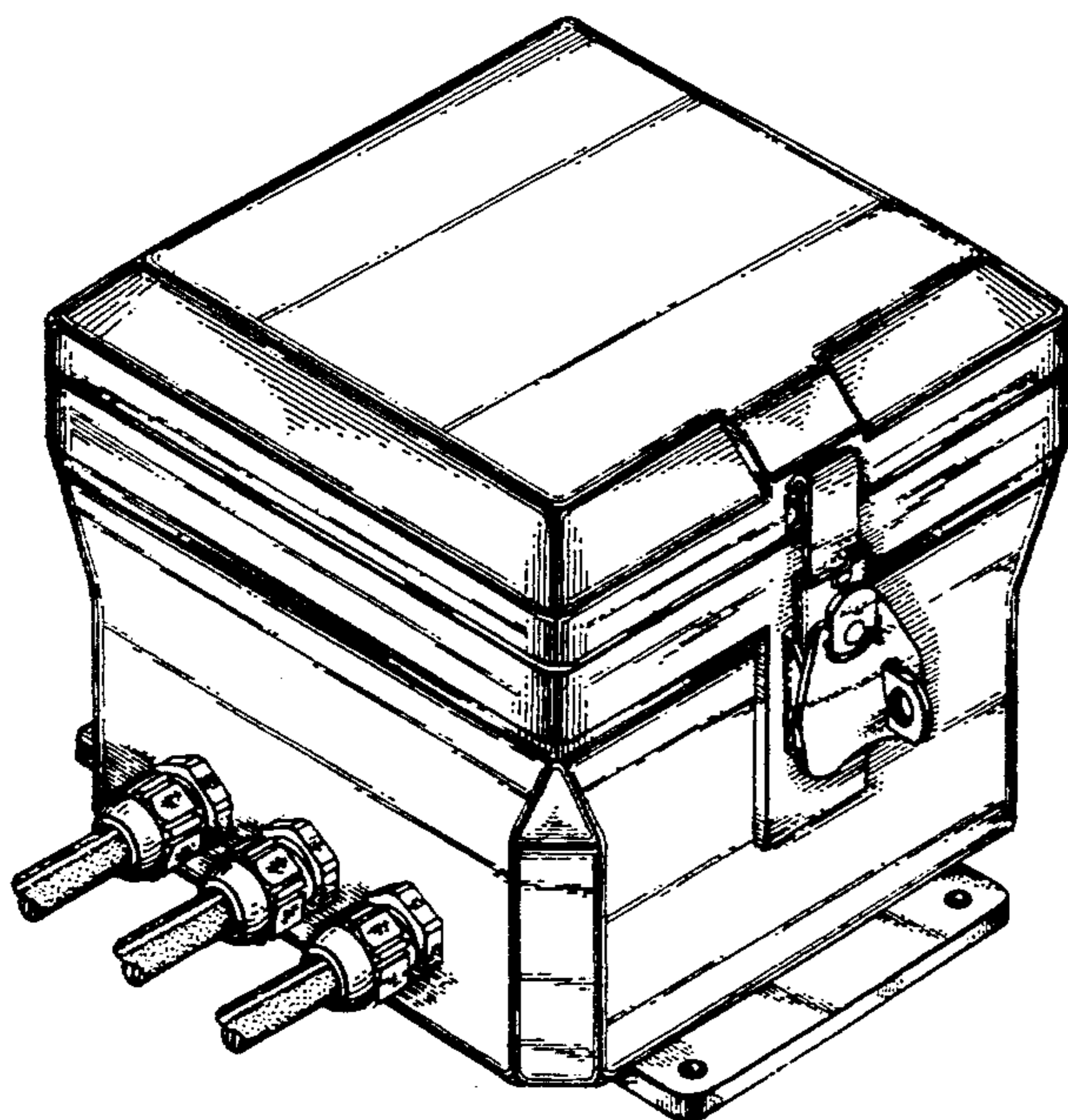

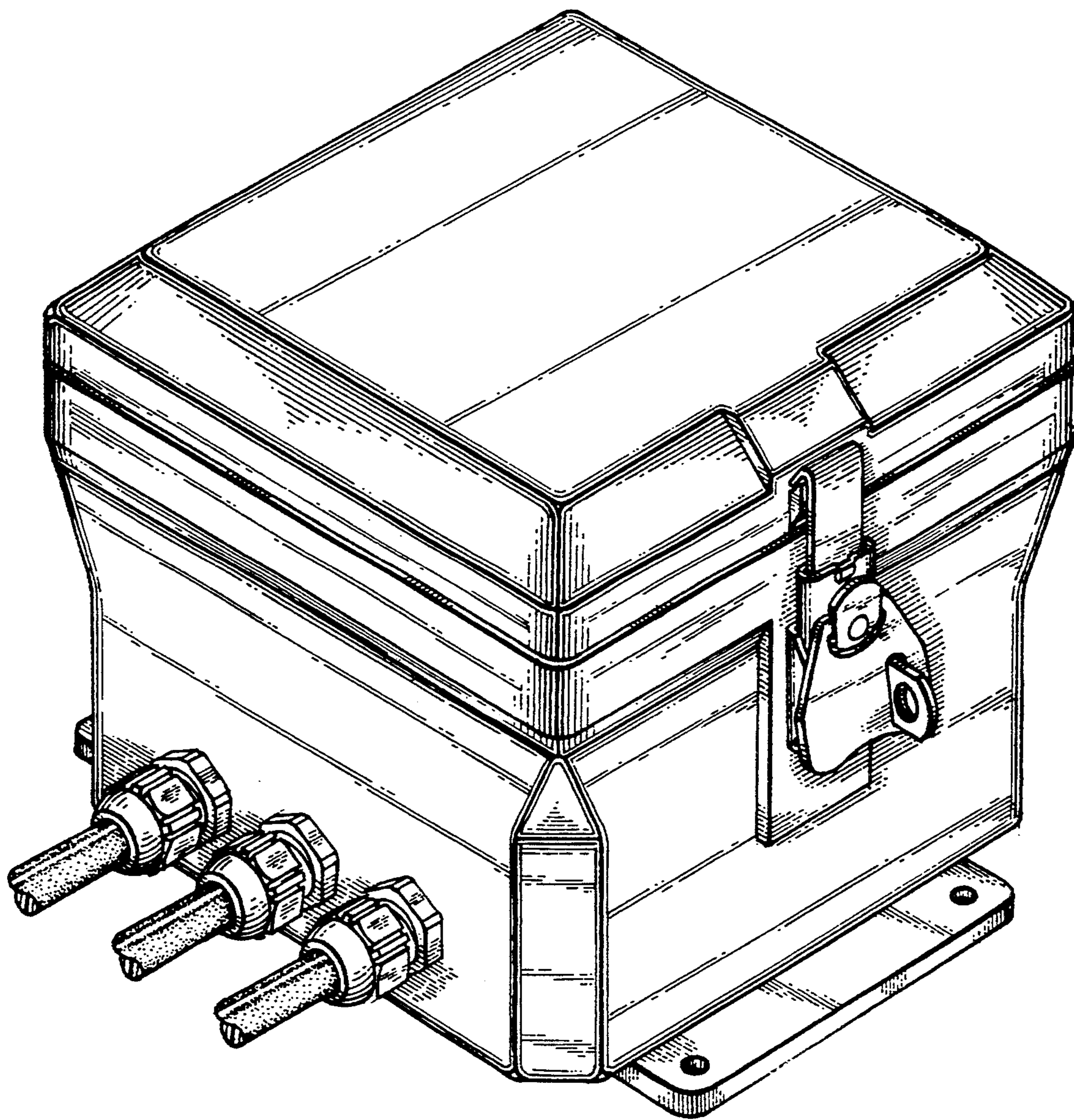

FIG. 1

FIG. 2

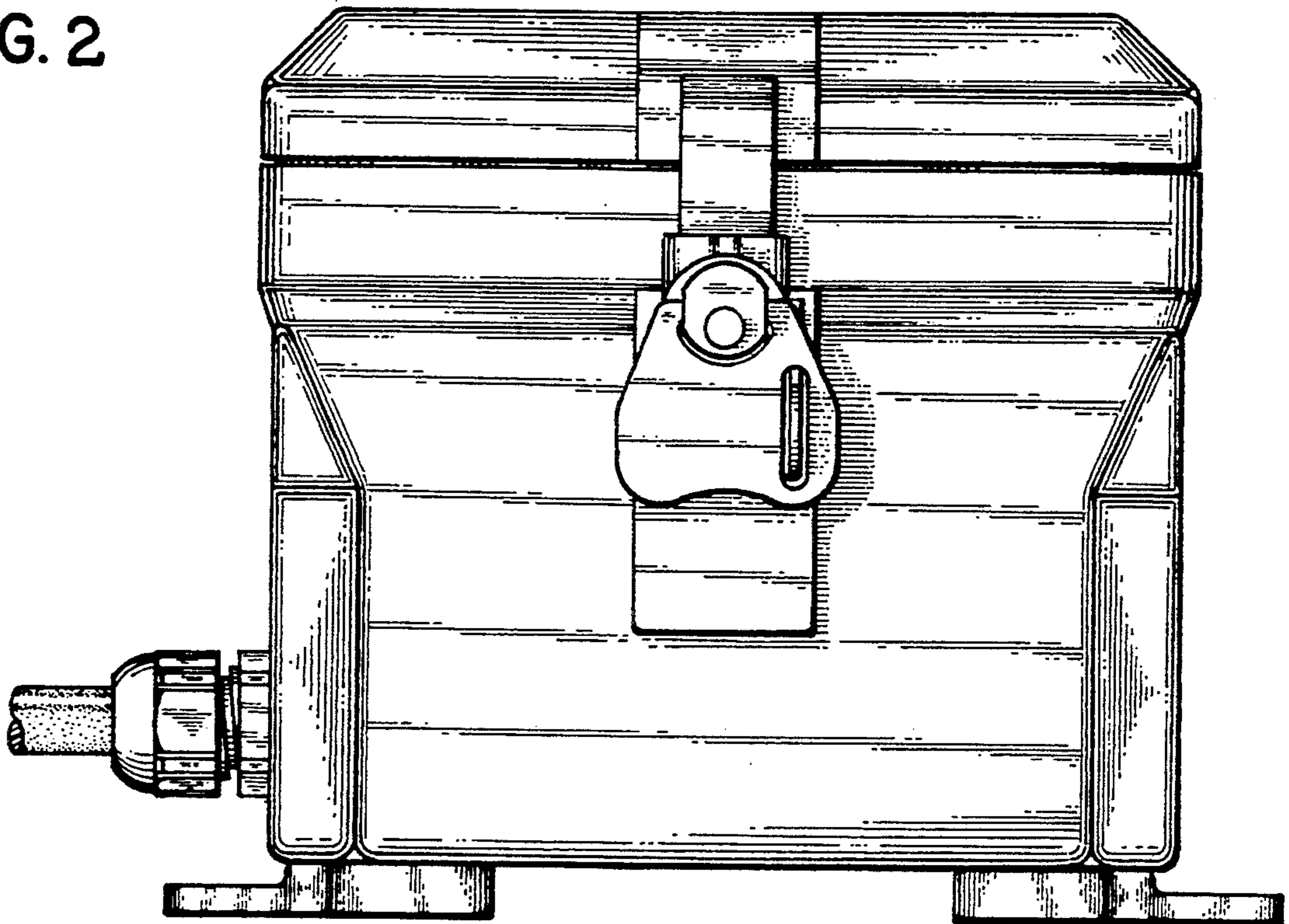

FIG. 3

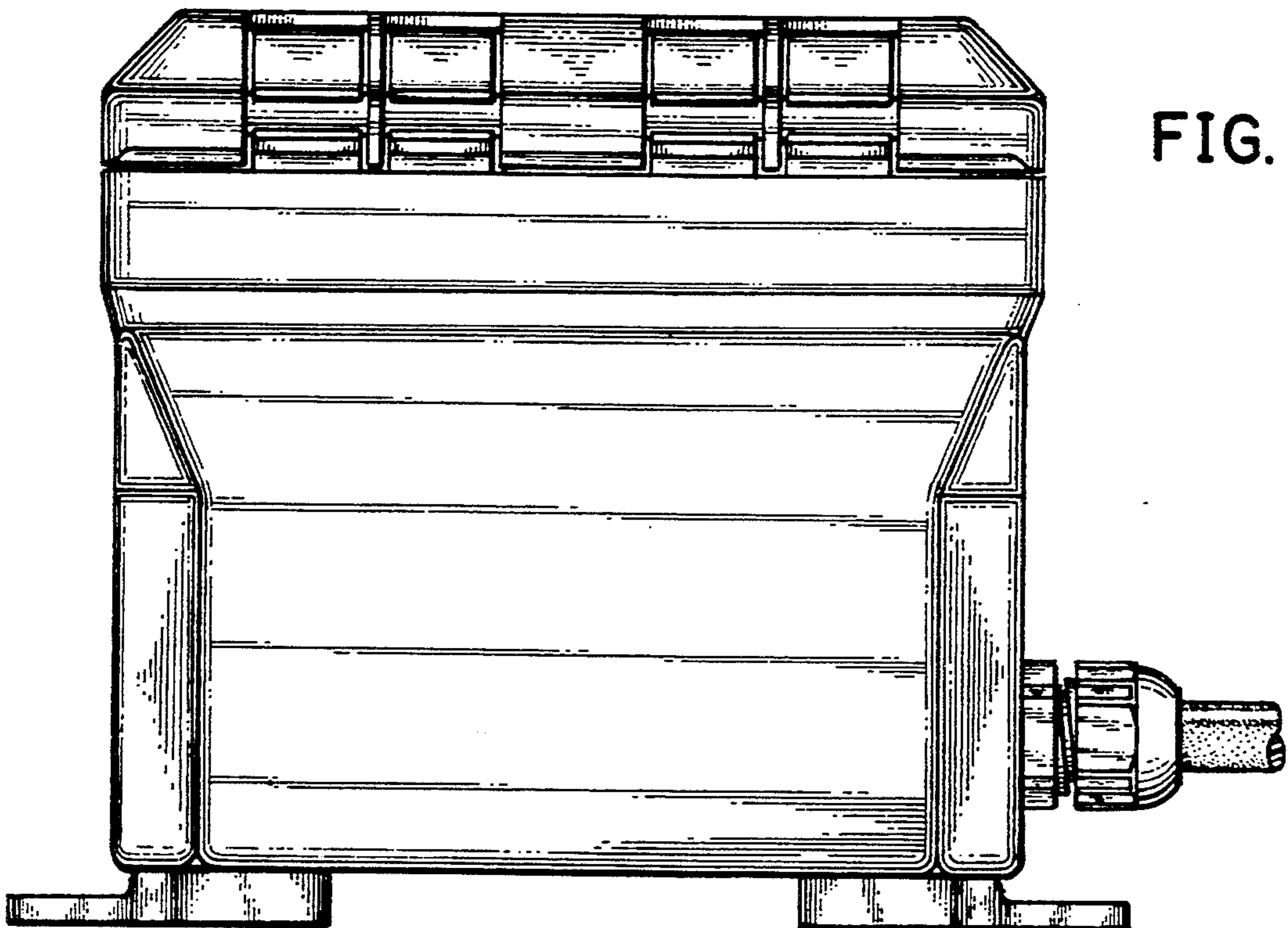

FIG. 4

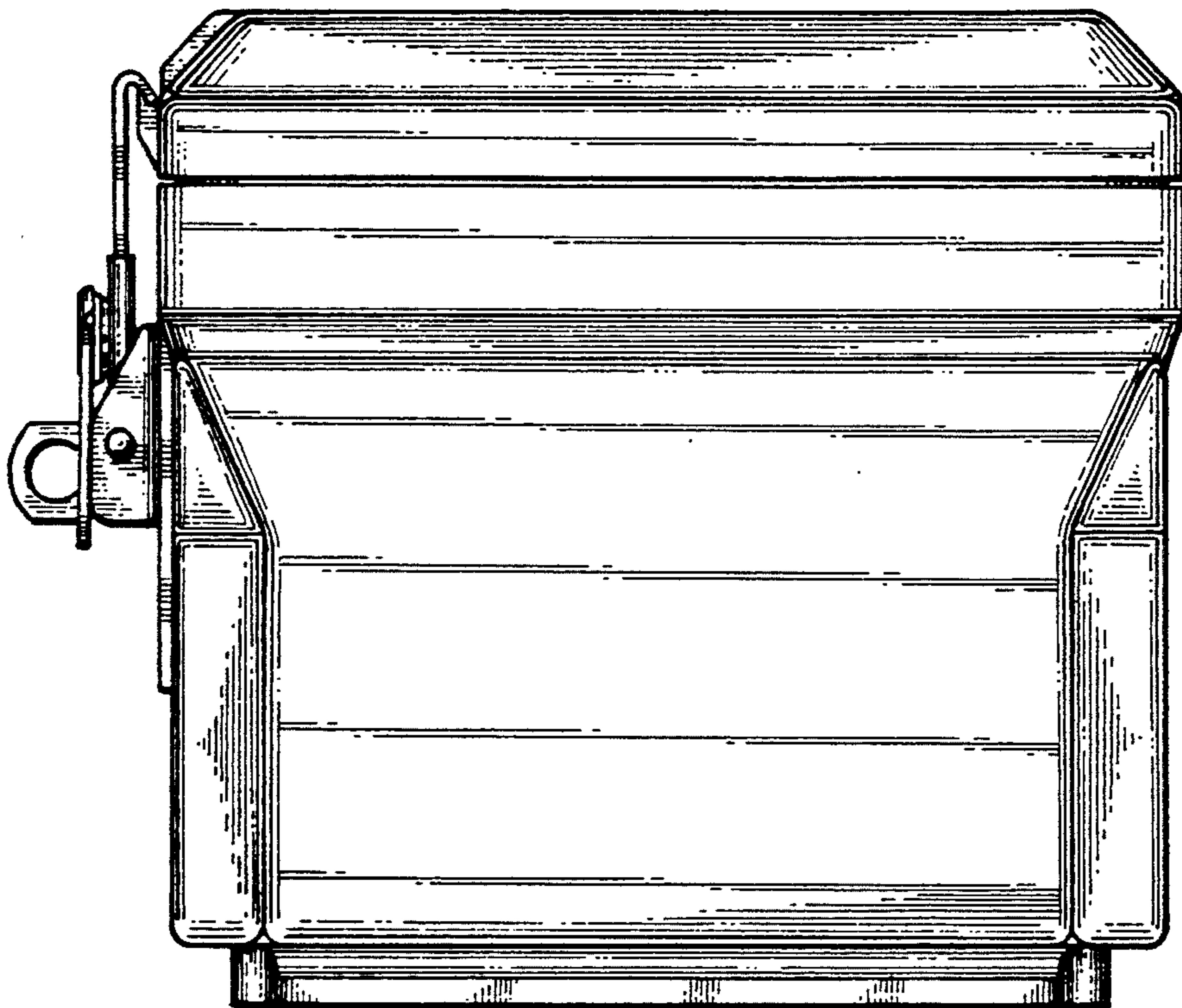
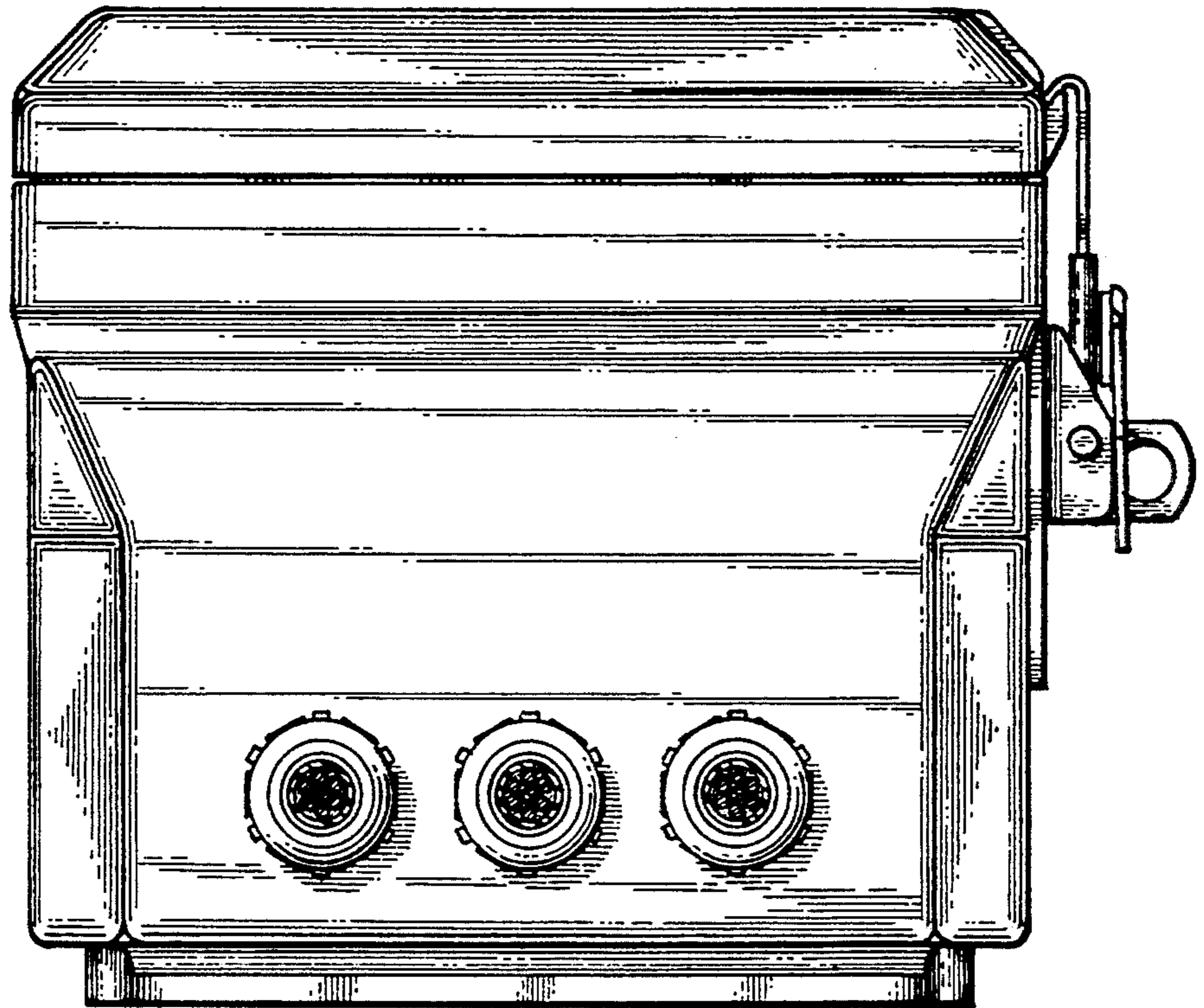

FIG. 5

FIG. 6

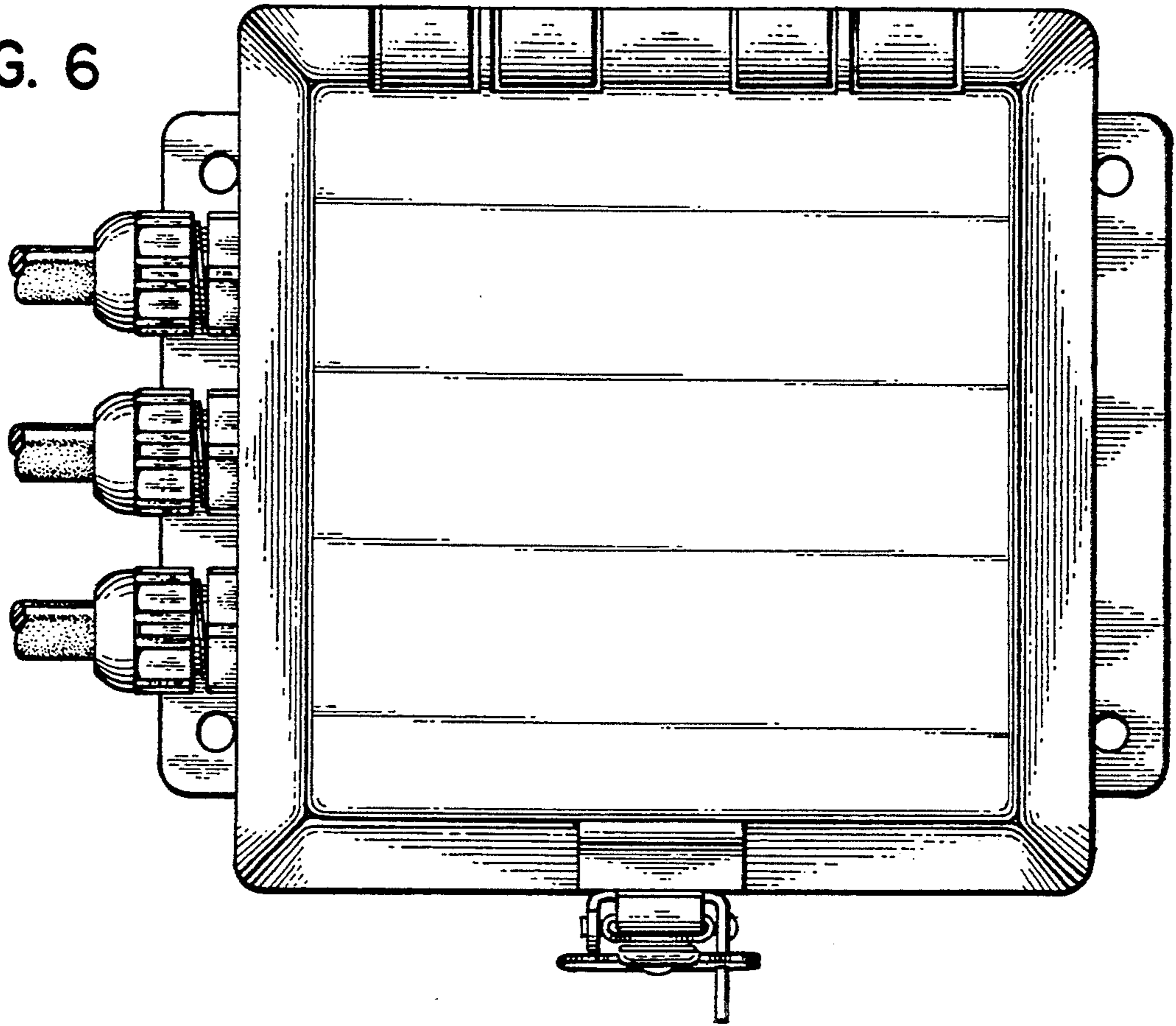
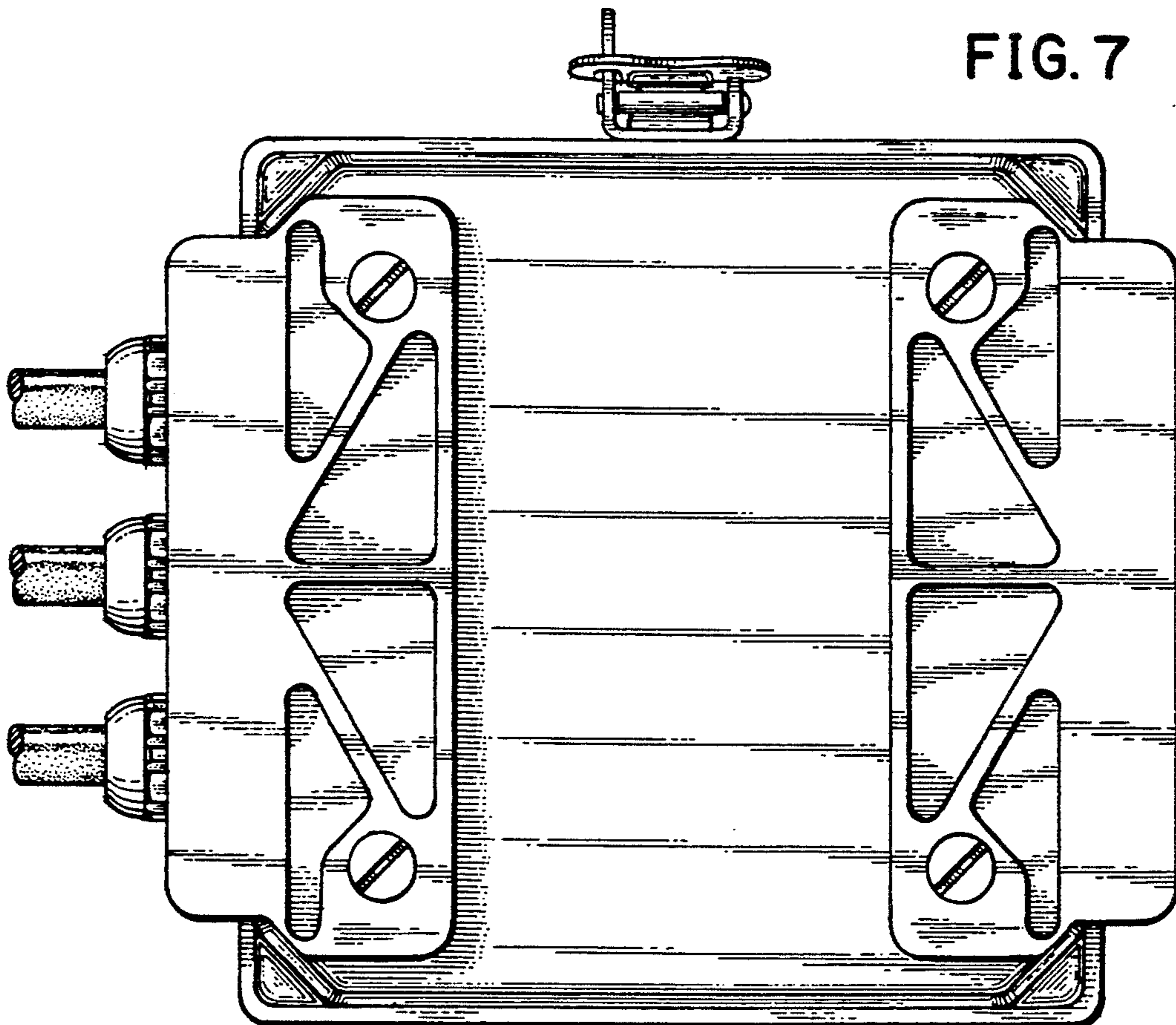

FIG. 7



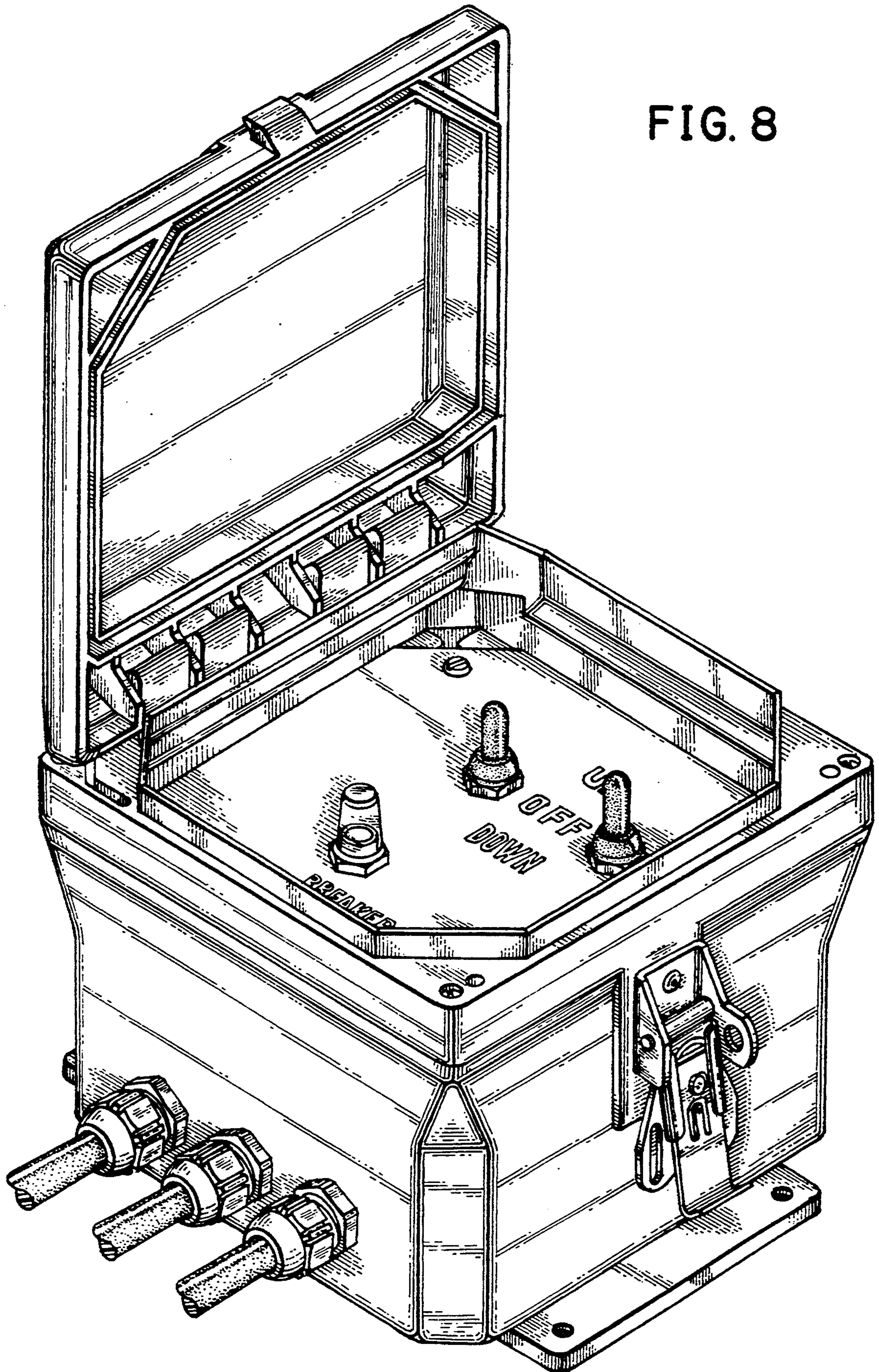

FIG. 9

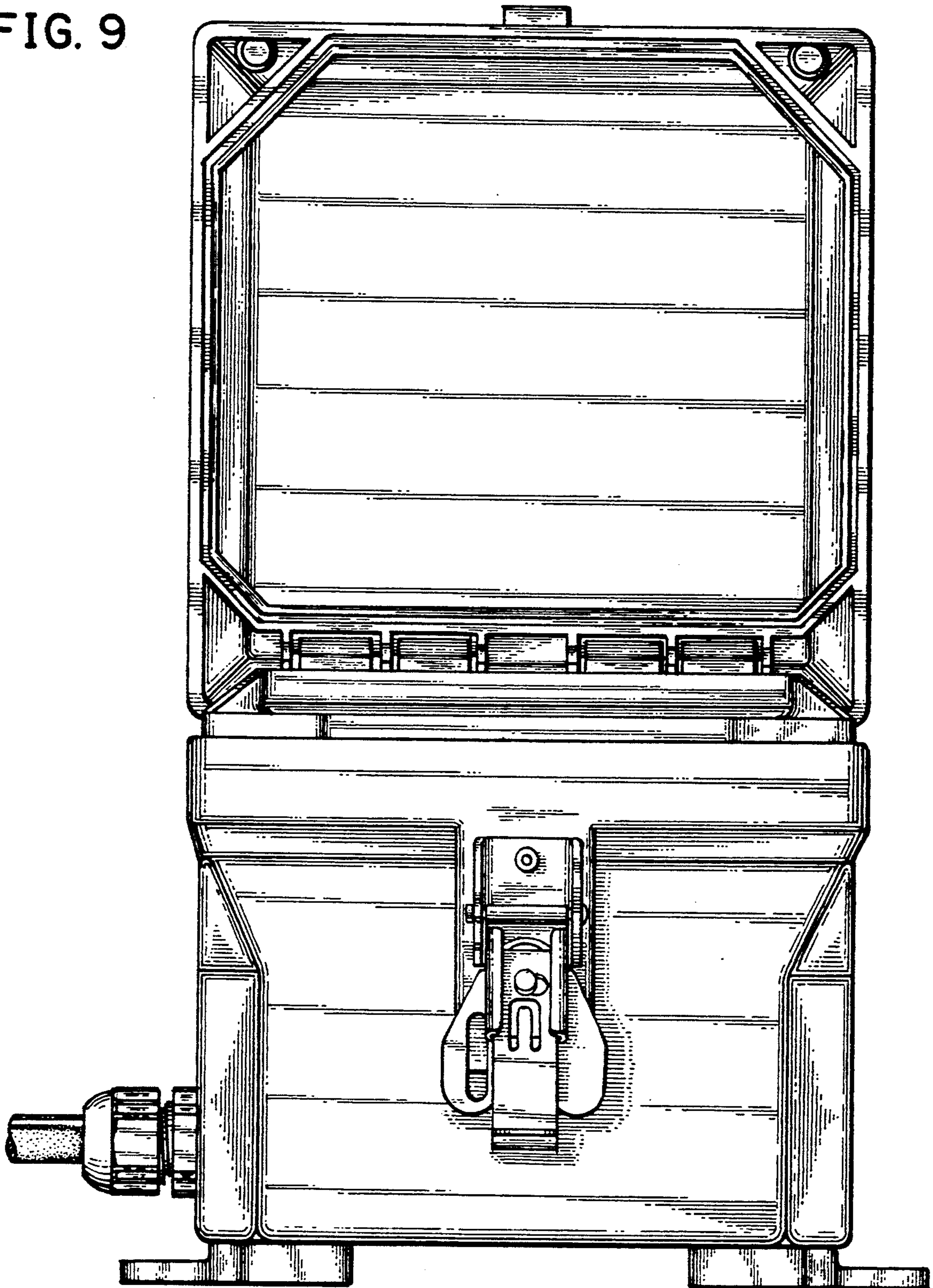

FIG. 10

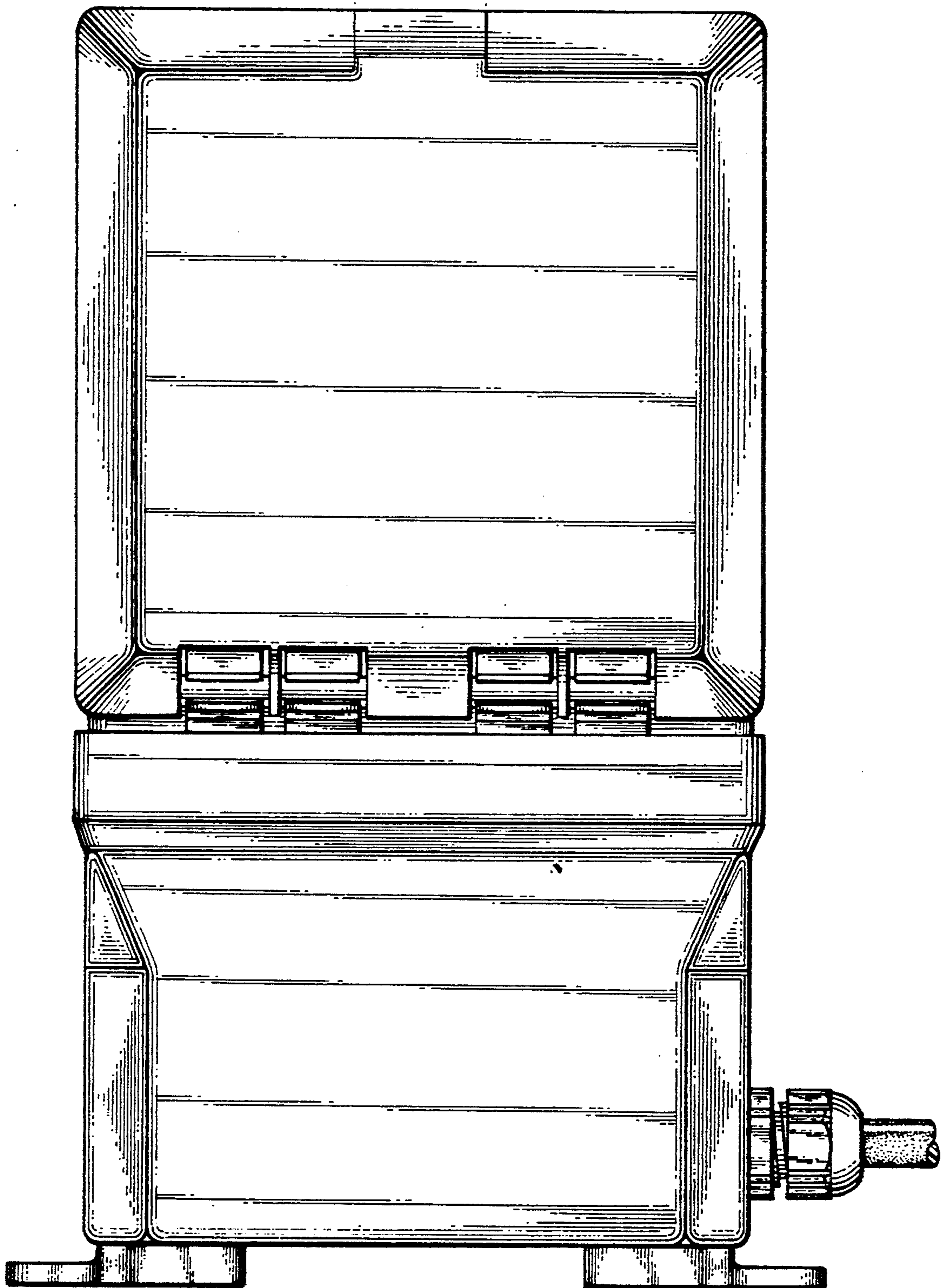



FIG. 11

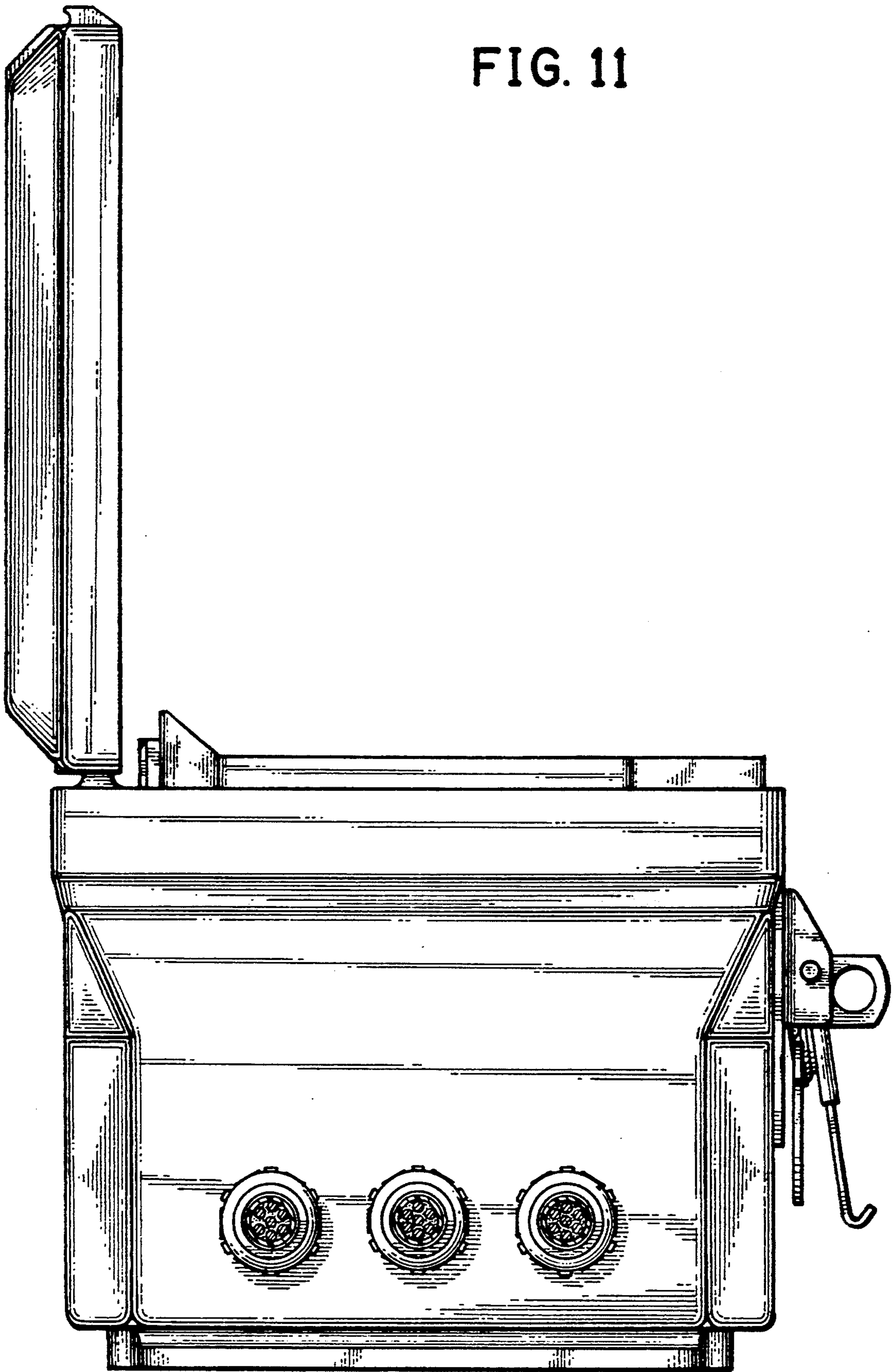

FIG. 12

