



US00D359941S

# United States Patent [19]

[11] Patent Number: **Des. 359,941**

Mannerfelt

[45] Date of Patent: **\*\* Jul. 4, 1995**

[54] BOAT

### FOREIGN PATENT DOCUMENTS

[76] Inventor: **Göran Mannerfelt**, Danderydsvägen  
69, S-182 62 Djursholm, Sweden

8809283 12/1988 WIPO ..... 114/56

### OTHER PUBLICATIONS

[\*\*] Term: **14 Years**

“Racer Med Vingar”, published in Form Mar. 1992.

[21] Appl. No.: **18,398**

*Primary Examiner*—Kay H. Chin  
*Attorney, Agent, or Firm*—Klarquist Sparkman  
Campbell Leigh & Whinston

[22] Filed: **Feb. 4, 1994**

### [57] CLAIM

[52] U.S. Cl. .... **D12/314; D12/313**

The ornamental design for the boat, as shown and described.

[58] Field of Search ..... **D12/300, 310, 311, 312,  
D12/313, 314; 114/271, 56, 291**

### DESCRIPTION

### [56] References Cited

#### U.S. PATENT DOCUMENTS

D. 222,510	10/1971	Centaro .....	D12/300
5,046,439	9/1991	Goodson et al. ....	114/271
5,351,642	10/1994	Ackerbloom .....	114/291

FIG. 1 is an elevational side view of the right side of the boat, the opposite side being the same. The boat is illustrated in an attitude in which the boat rests in water; FIG. 2 is a rear view of the boat; FIG. 3 is a top view of the boat; FIG. 4 is a front view of the boat; and, FIG. 5 is a bottom view of the boat.

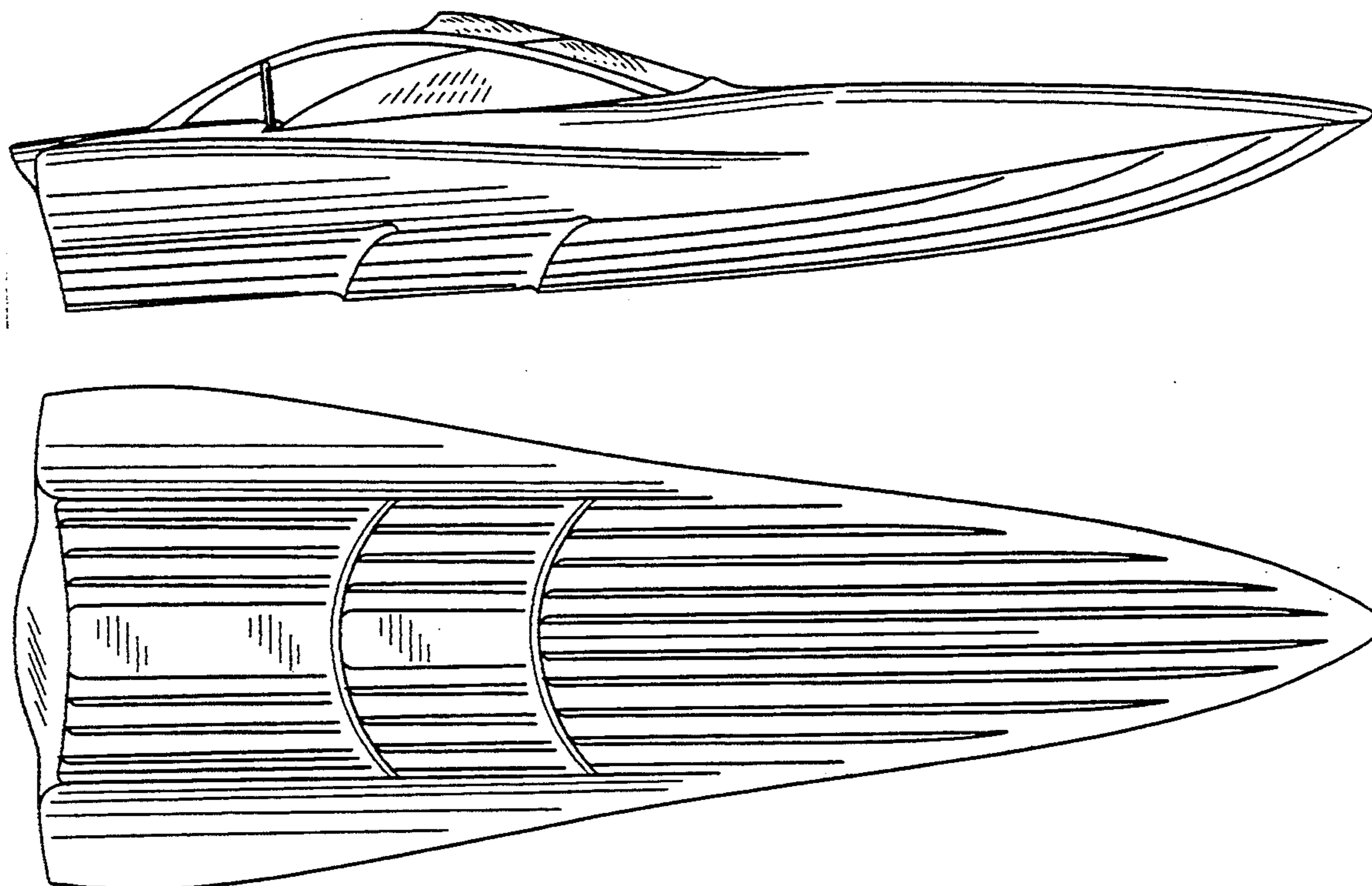

FIG. 1

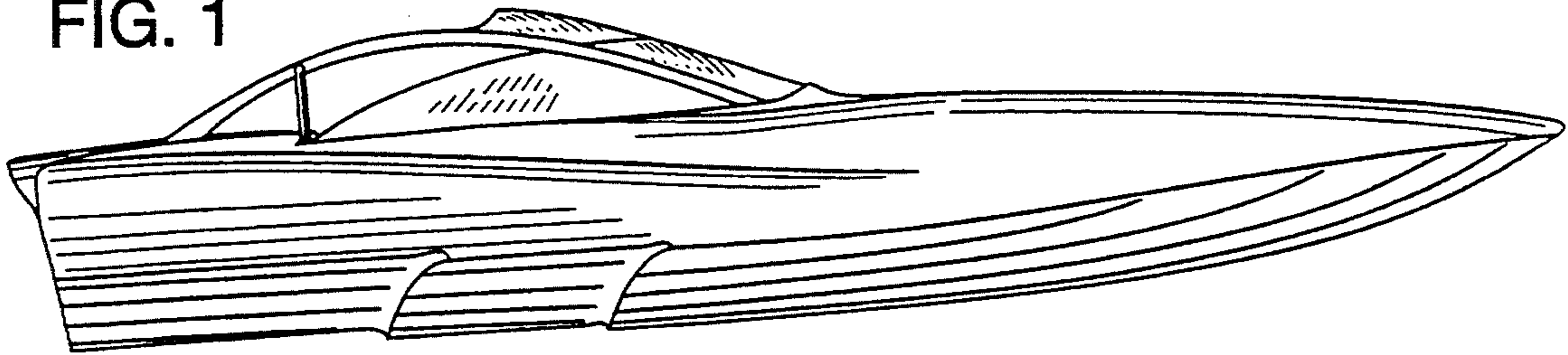

FIG. 4

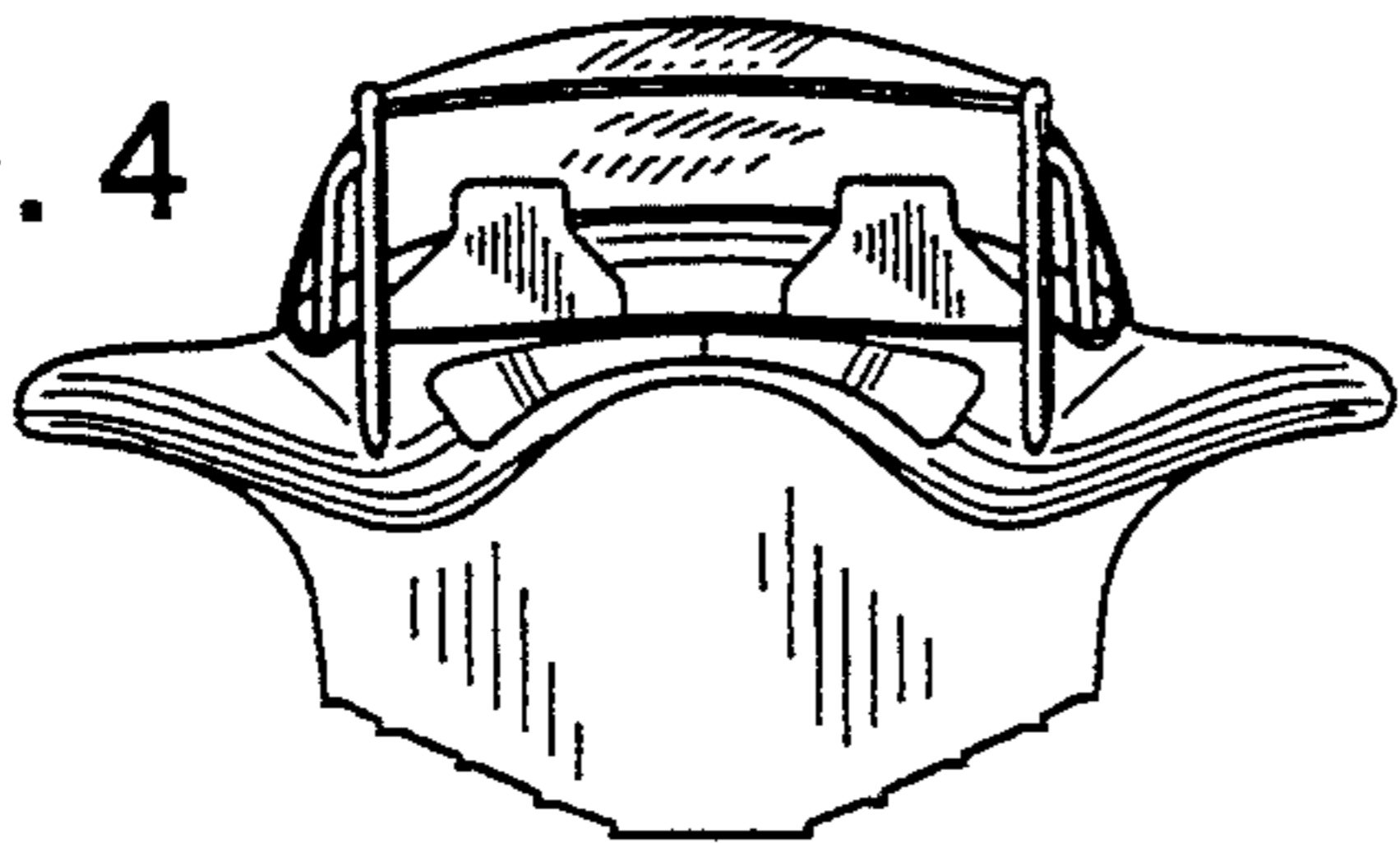

FIG. 2

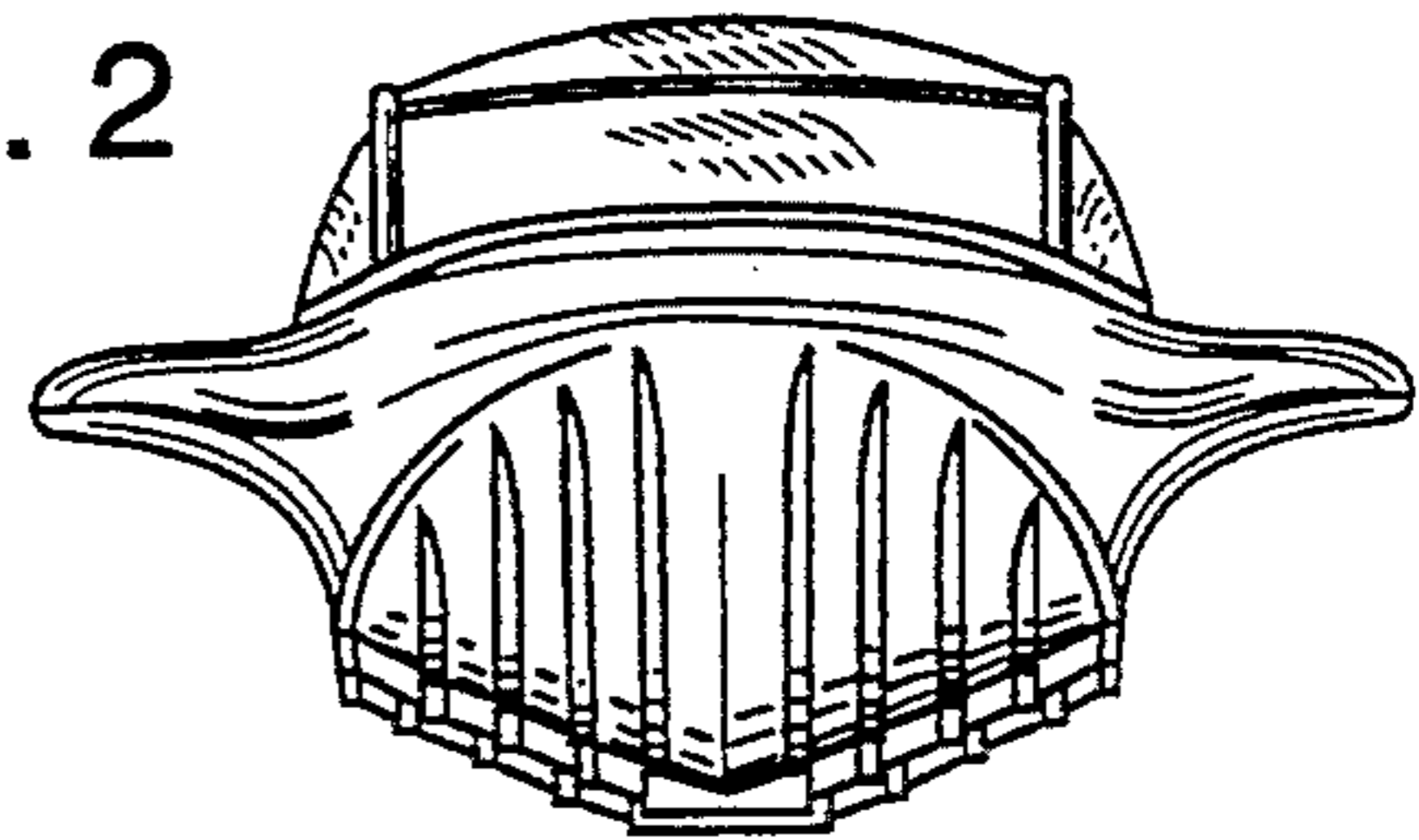

FIG. 3

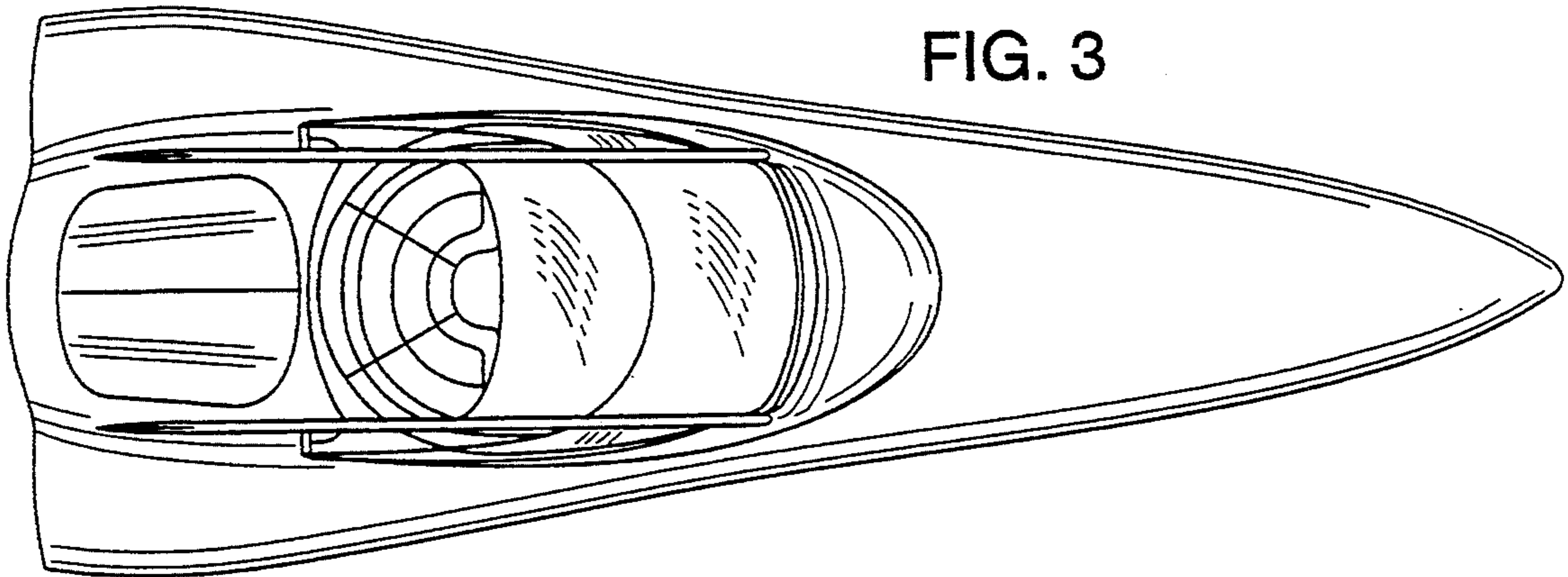

FIG. 5

