



US00D359857S

United States Patent [19]

[11] Patent Number: **Des. 359,857**

Bartlett

[45] Date of Patent: **** Jul. 4, 1995**

[54] **COMBINED MOTORIZED SWING AND CANOPY**

3,794,317 2/1974 Barrett 297/274 X
4,293,162 10/1981 Pap et al. D6/333 X

[76] Inventor: **Rella M. Bartlett**, P.O. Box 168,
Newton Junction, N.H. 03859

Primary Examiner—Louis S. Zarfes
Assistant Examiner—Monica A. Hannon
Attorney, Agent, or Firm—H. Jay Spiegel

[**] Term: **14 Years**

[57] **CLAIM**

[21] Appl. No.: **18,531**

The ornamental design for a combined motorized swing and canopy, as shown and described.

[22] Filed: **Feb. 9, 1994**

[52] U.S. Cl. **D6/347; D6/344**

[58] Field of Search D6/344, 345, 346, 333,
D6/334, 335, 336, 347, 351, 353, 356, 358, 359,
390, 500, 501, 502; 297/181, 191, 192, 193,
184.13, 260, 274, 452.12, 452.15, 452.16, 452.7

DESCRIPTION

[56] **References Cited**

U.S. PATENT DOCUMENTS

D. 298,187	10/1988	Lacewell	D6/347
2,618,318	11/1952	Welsh	297/274 X
2,697,477	12/1954	Welsh	297/274 X
2,912,044	11/1959	Giffen	297/274 X

FIG. 1 shows a perspective view of the present invention;
FIG. 2 shows a front view of the present invention;
FIG. 3 shows a rear view of the present invention;
FIG. 4 shows a side view of the present invention; and,
FIG. 5 shows the other side view of the present invention.

The broken line disclosure of a bar in FIGS. 1-5 is for illustrative purposes only and forms no part of the claimed design.

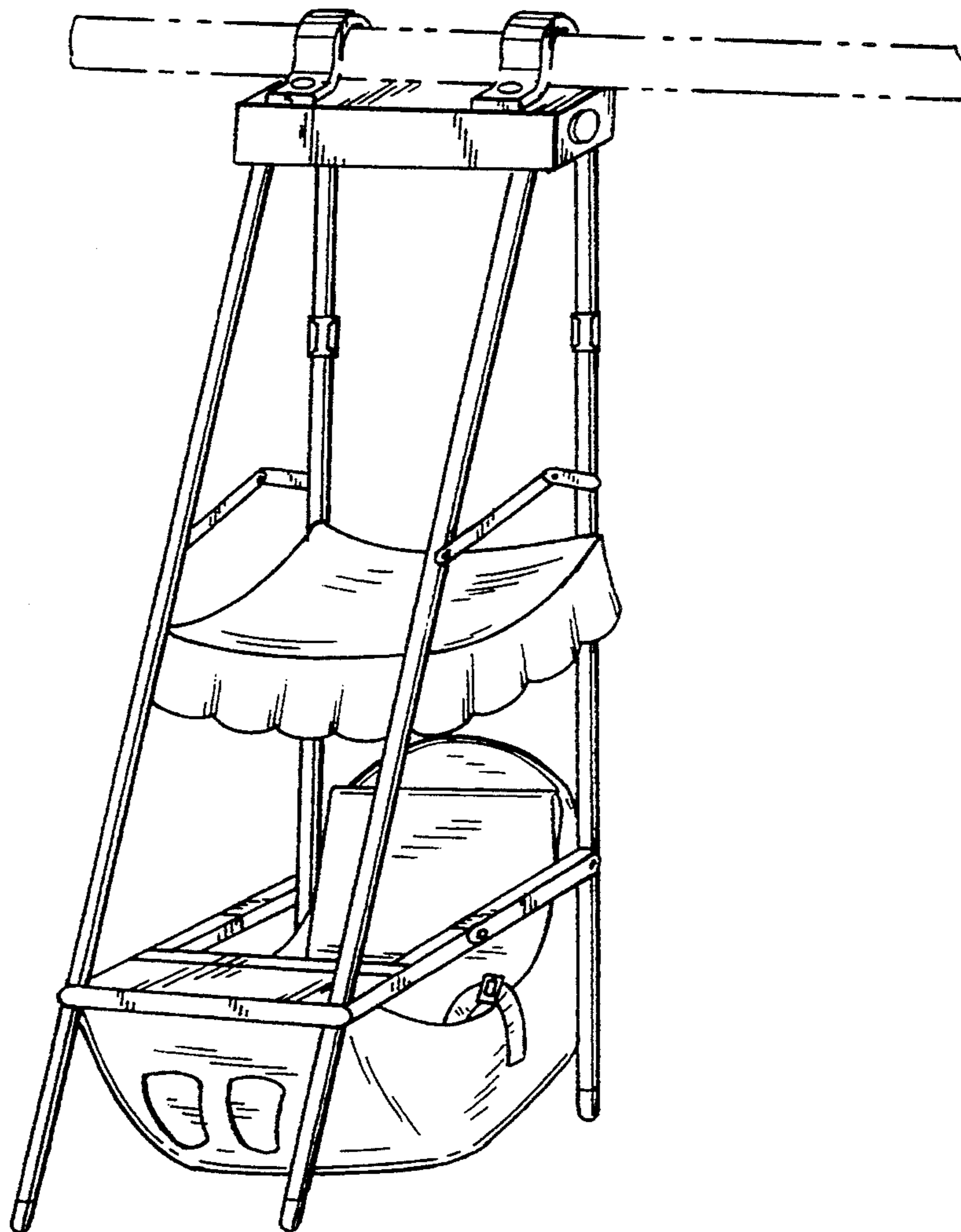

FIG. 1

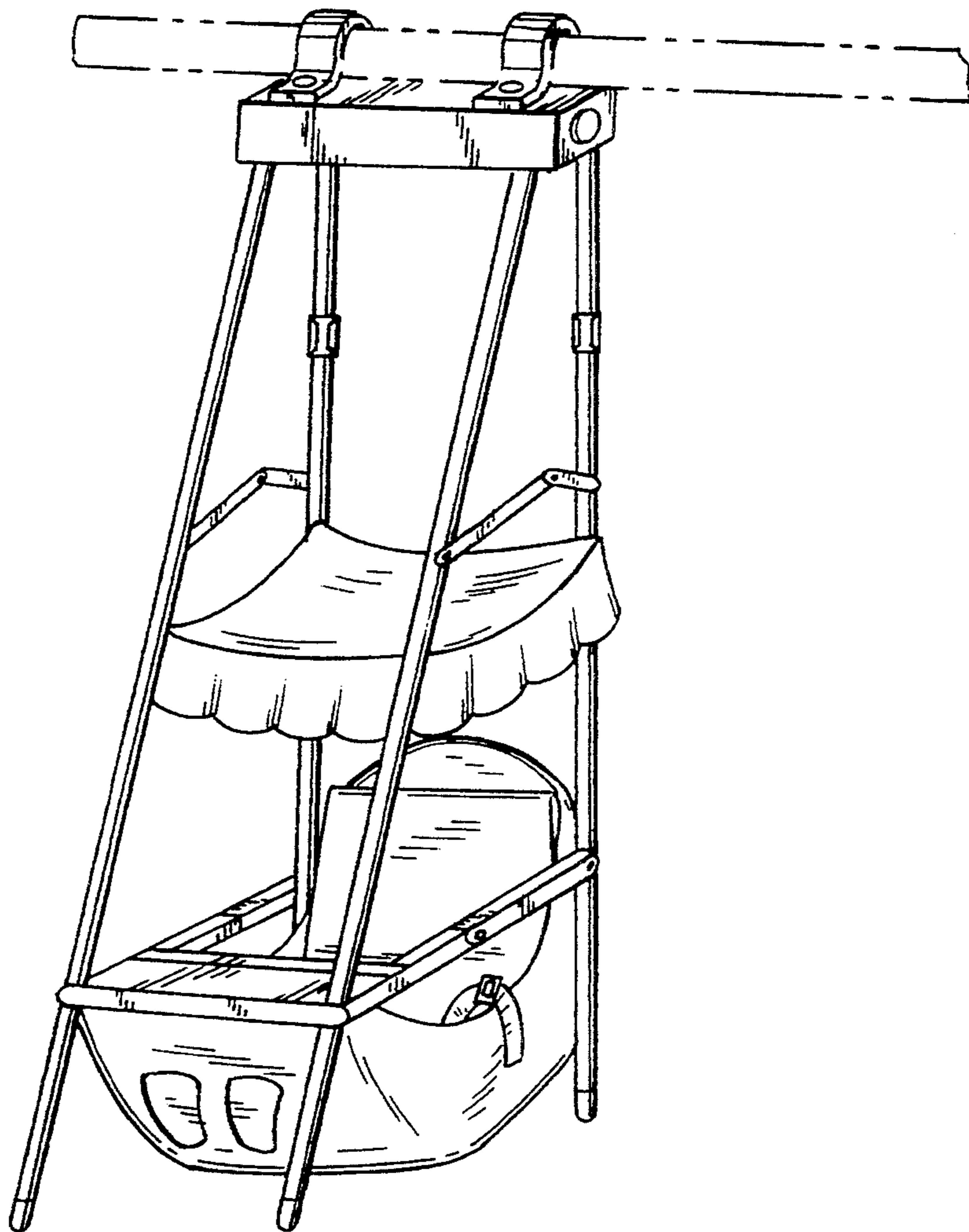

FIG. 2

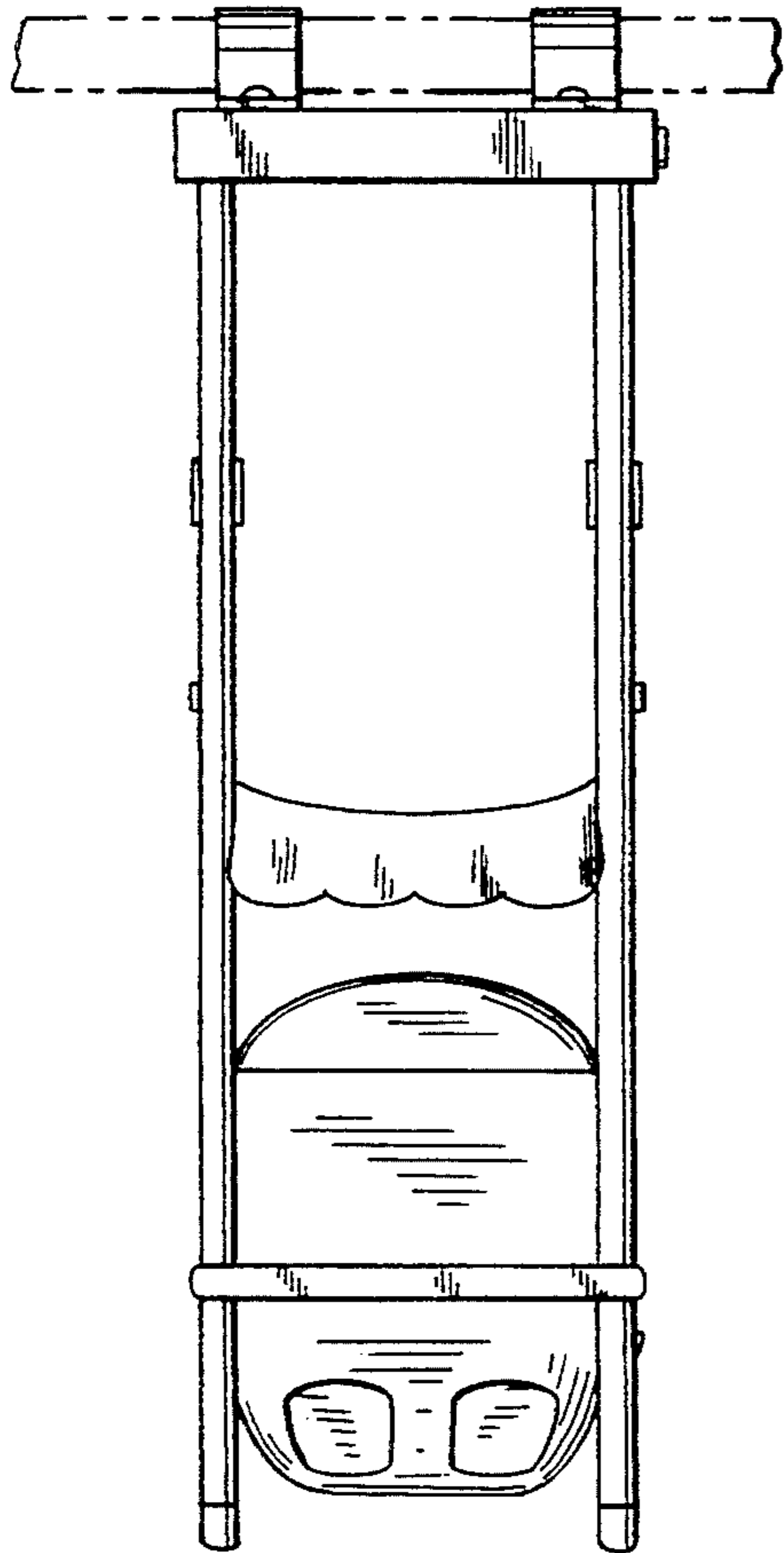

FIG. 3

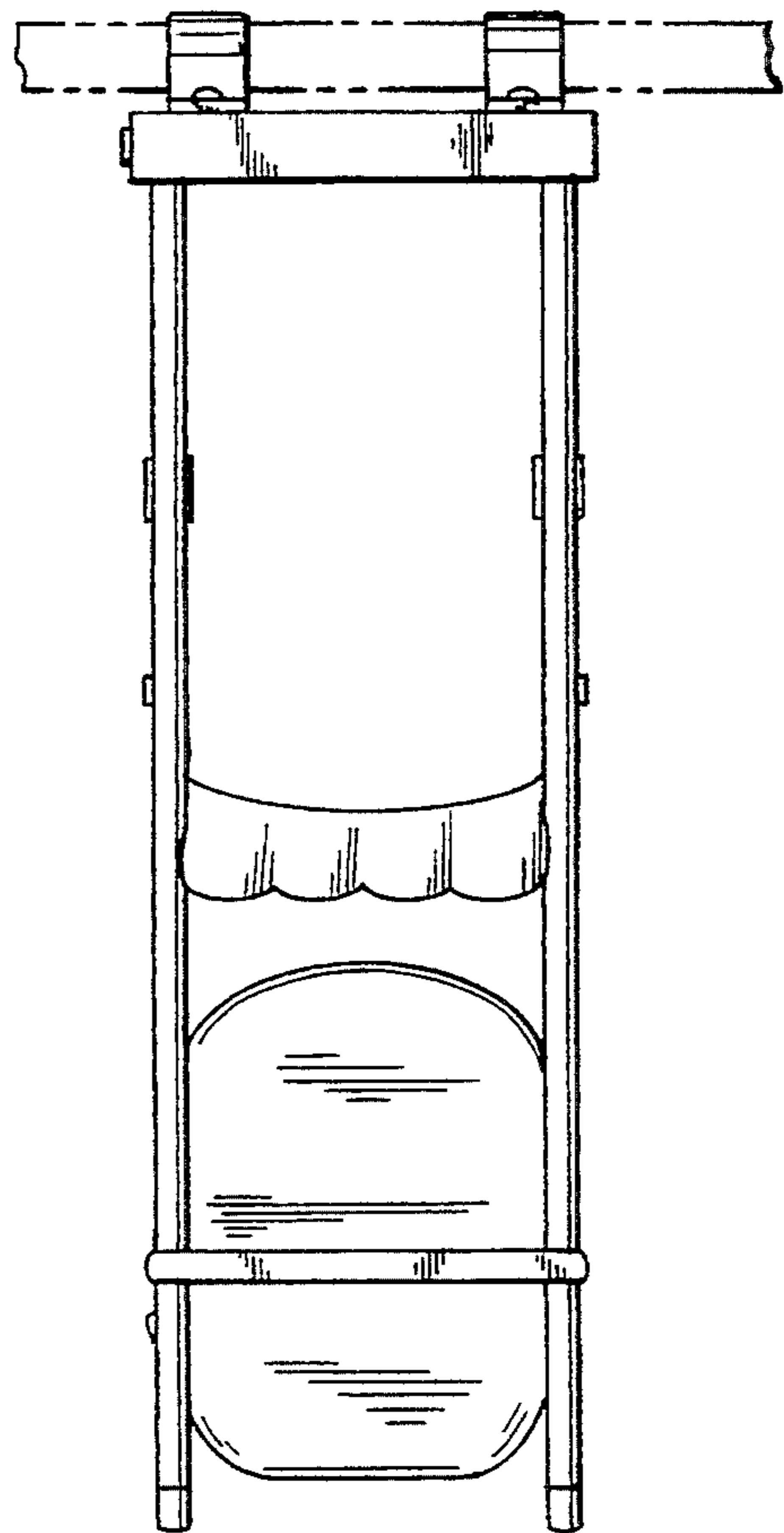

FIG. 4

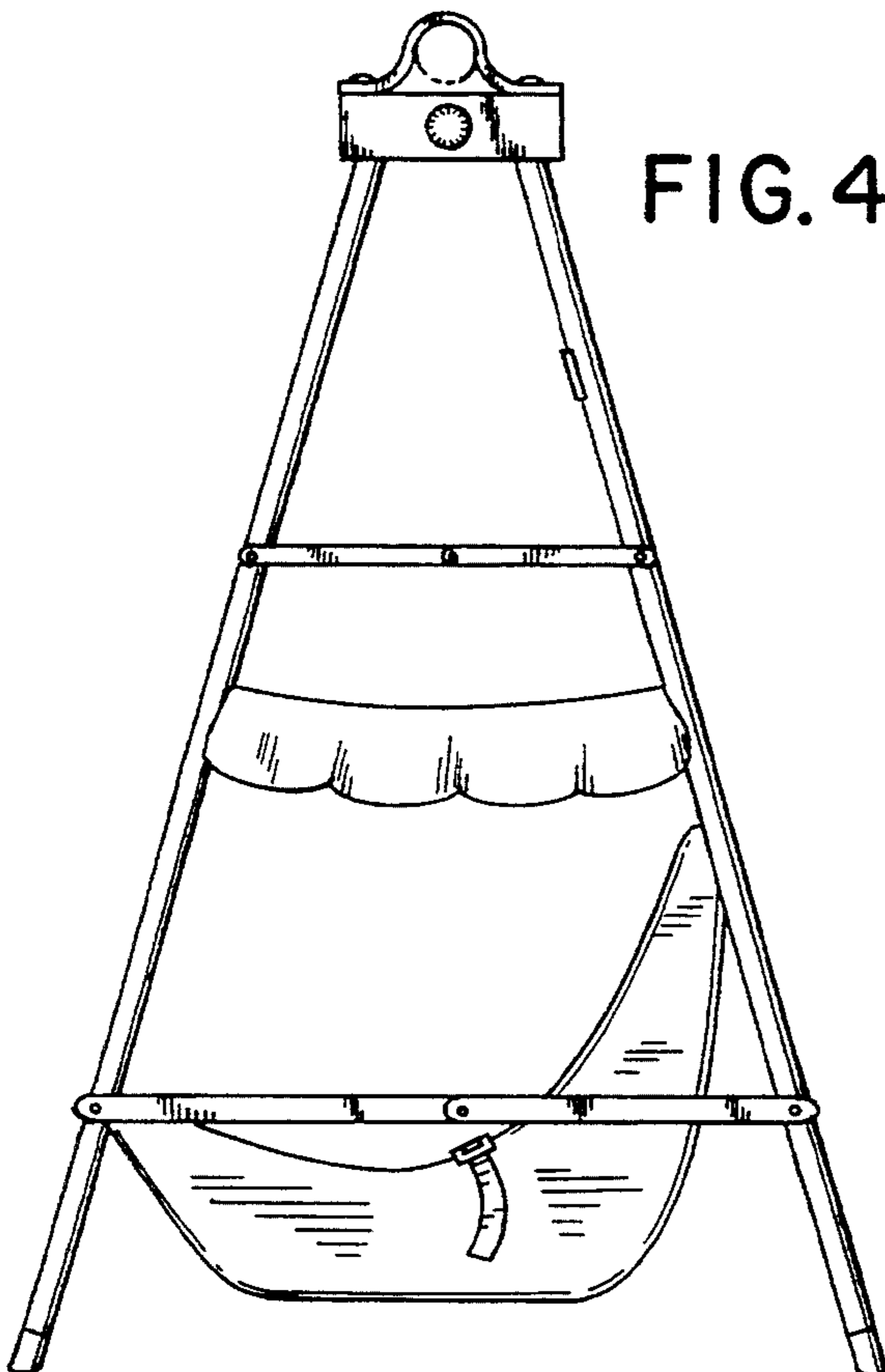

FIG. 5

