



US00D359688S

United States Patent [19]

[11] Patent Number: **Des. 359,688**

Rosen

[45] Date of Patent: **** Jun. 27, 1995**

[54] **PERFUME BOTTLE**

[75] Inventor: **Marc A. Rosen**, New York, N.Y.

[73] Assignee: **Halston Borghese International**

[**] Term: **14 Years**

[21] Appl. No.: **16,399**

[22] Filed: **Dec. 16, 1993**

[52] U.S. Cl. **D9/504; D9/502; D9/452**

[58] Field of Search **D9/500, 502, 503, 504, D9/505, 545, 558, 557, 529, 452, 454; D24/224; 215/1 R, 1 C, 329**

[56] **References Cited**

U.S. PATENT DOCUMENTS

D. 124,880	1/1941	Teunisz	D9/500
D. 223,437	4/1972	Lluch	D9/504
D. 310,329	9/1990	Schmidt	D9/454

OTHER PUBLICATIONS

Kimble Laboratory Glassware, Mar. 1962, p. 113, flask #26560.

Beauty Fashion, May 1985, p. 31, Shiseido bottle cap.

Primary Examiner—Lucy J. Lieberman
Attorney, Agent, or Firm—Baker & Friedman; Michael Marinangeli

[57] **CLAIM**

The ornamental design for a perfume bottle, as shown and described.

DESCRIPTION

FIG. 1 is a perspective view of perfume bottle showing my new design;

FIG. 2 is a top view of the perfume bottle of FIG. 1; and,

FIG. 3 is a front elevation view of the perfume bottle, the rear and side elevations are the same.

The bottom of the perfume bottle is flat and unornamented.

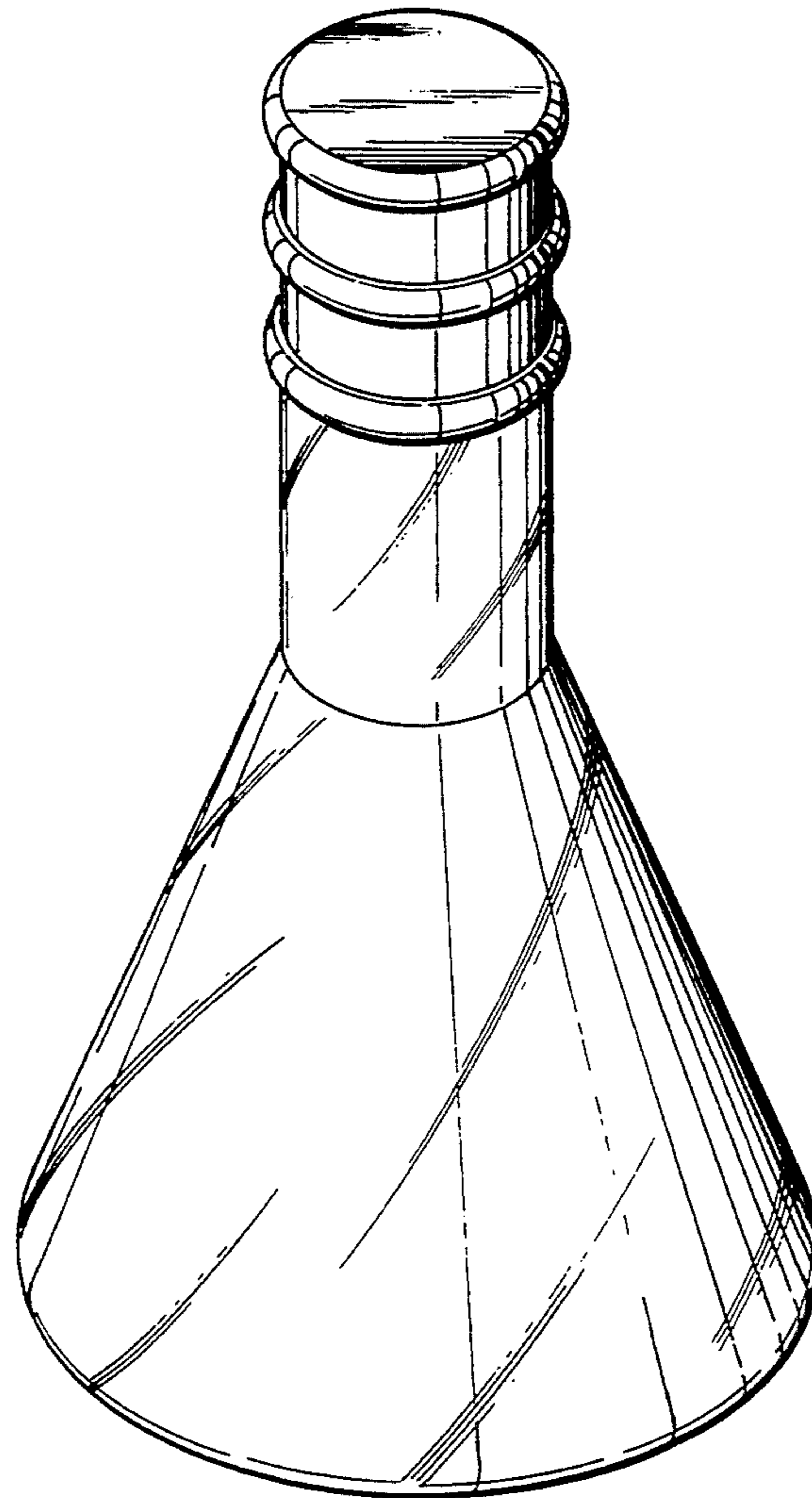

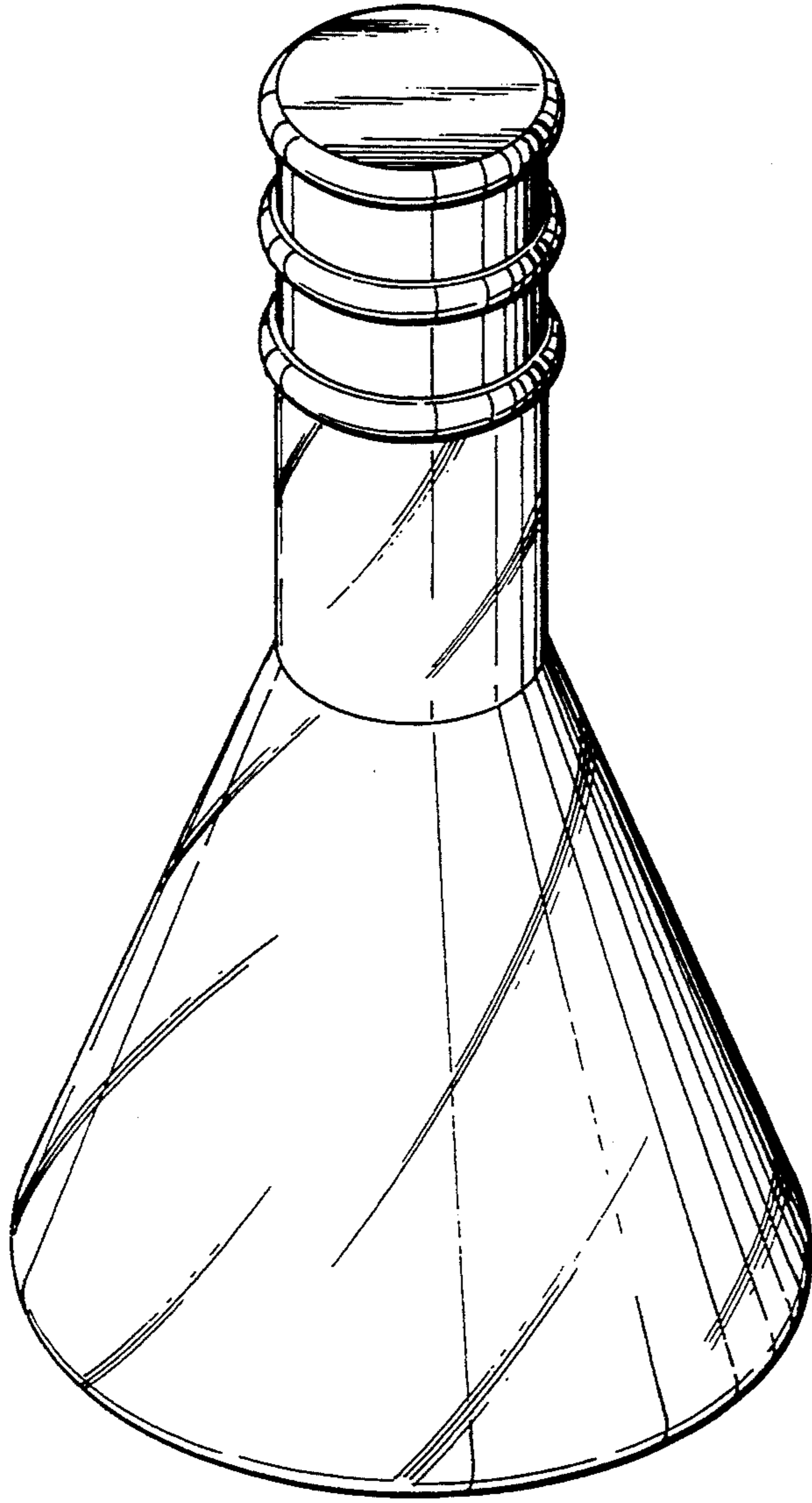

Fig. 1.

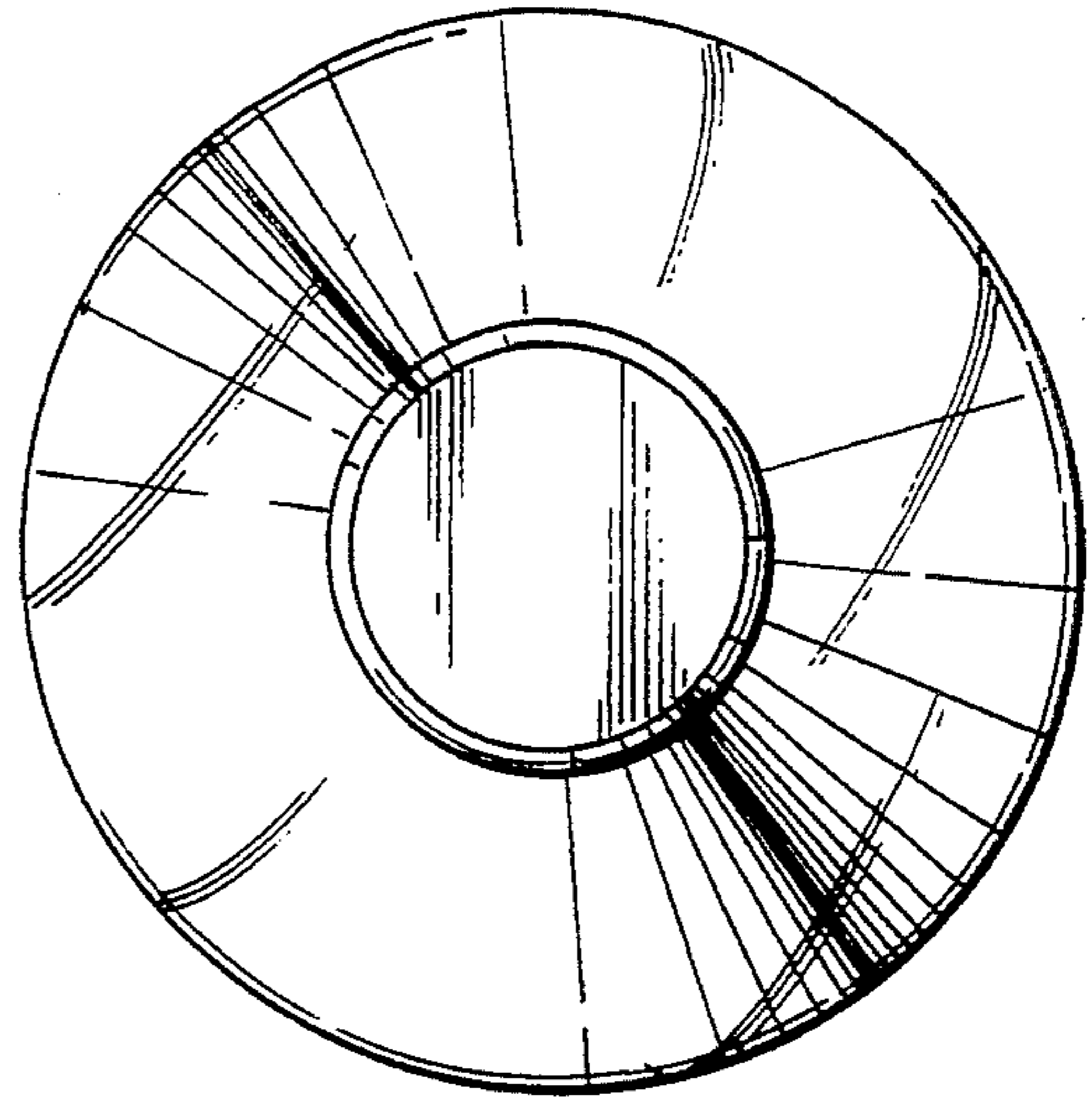

Fig. 2.

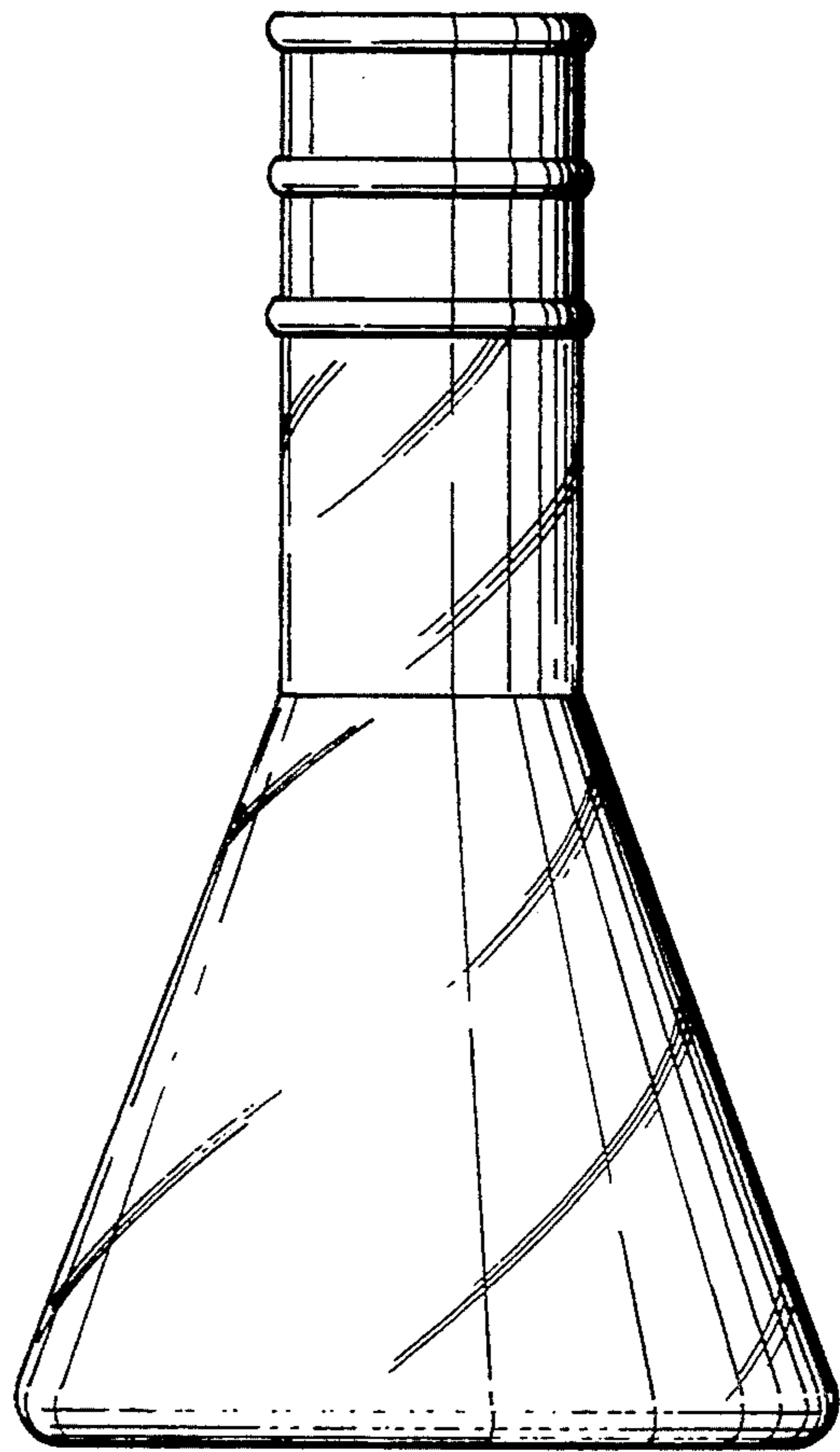

Fig. 3.