



US00D359466S

United States Patent [19]

[11] Patent Number: **Des. 359,466**

Eggers et al.

[45] Date of Patent: **** Jun. 20, 1995**

[54] **CYCLE WHEEL LOCKING BRACKET**

4,352,432 10/1982 Smith 211/19

[76] Inventors: **Steven R. Eggers; Sonia E. Garden,**
both of 73 Hartung Street,
Mundaring 6073, Australia

OTHER PUBLICATIONS

Cycle-Safe brochure.

[**] Term: **14 Years**

Primary Examiner—Brian N. Vinson

Attorney, Agent, or Firm—Larson and Taylor

[21] Appl. No.: **6,242**

[57] CLAIM

[22] Filed: **Mar. 22, 1993**

The ornamental design of a cycle wheel locking bracket, as shown and described.

[30] Foreign Application Priority Data

DESCRIPTION

Sep. 21, 1992 [AU] Australia 2644/92

[52] U.S. Cl. **D12/115; D8/333**

[58] Field of Search **D8/343; D12/114, 115;**
248/499-500, 551, 680, 251, 309.1, 309.2;
20/57-58, 233-235; 211/17-24

FIG. 1 is a top, front, and right side perspective view of a cycle wheel locking bracket showing my new design; FIG. 2 is a top plan view thereof; FIG. 3 is a left side elevational view thereof; FIG. 4 is a rear elevational view thereof; FIG. 5 is a top, front, and right side perspective view of an alternate embodiment of a cycle wheel locking bracket showing my new design; FIG. 6 is a top plan view thereof; FIG. 7 is a left side elevational view thereof; and, FIG. 8 is a rear elevational view thereof.

[56] References Cited

U.S. PATENT DOCUMENTS

- D. 27,662 9/1897 Blethen D12/115
- D. 148,538 2/1948 Henkel D12/115
- D. 236,335 8/1975 Lacivita D12/115
- D. 298,524 11/1988 De Luca D12/115

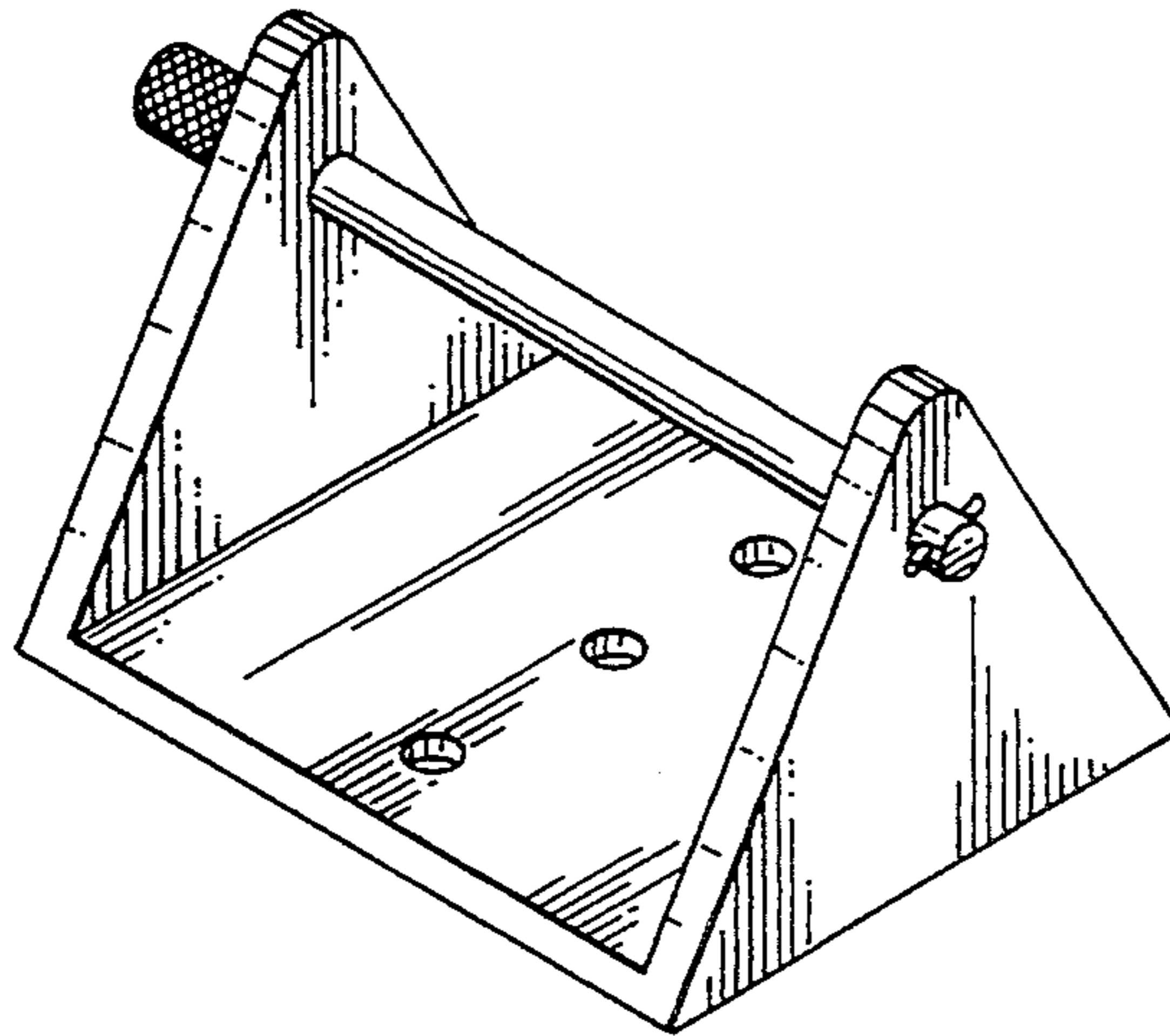
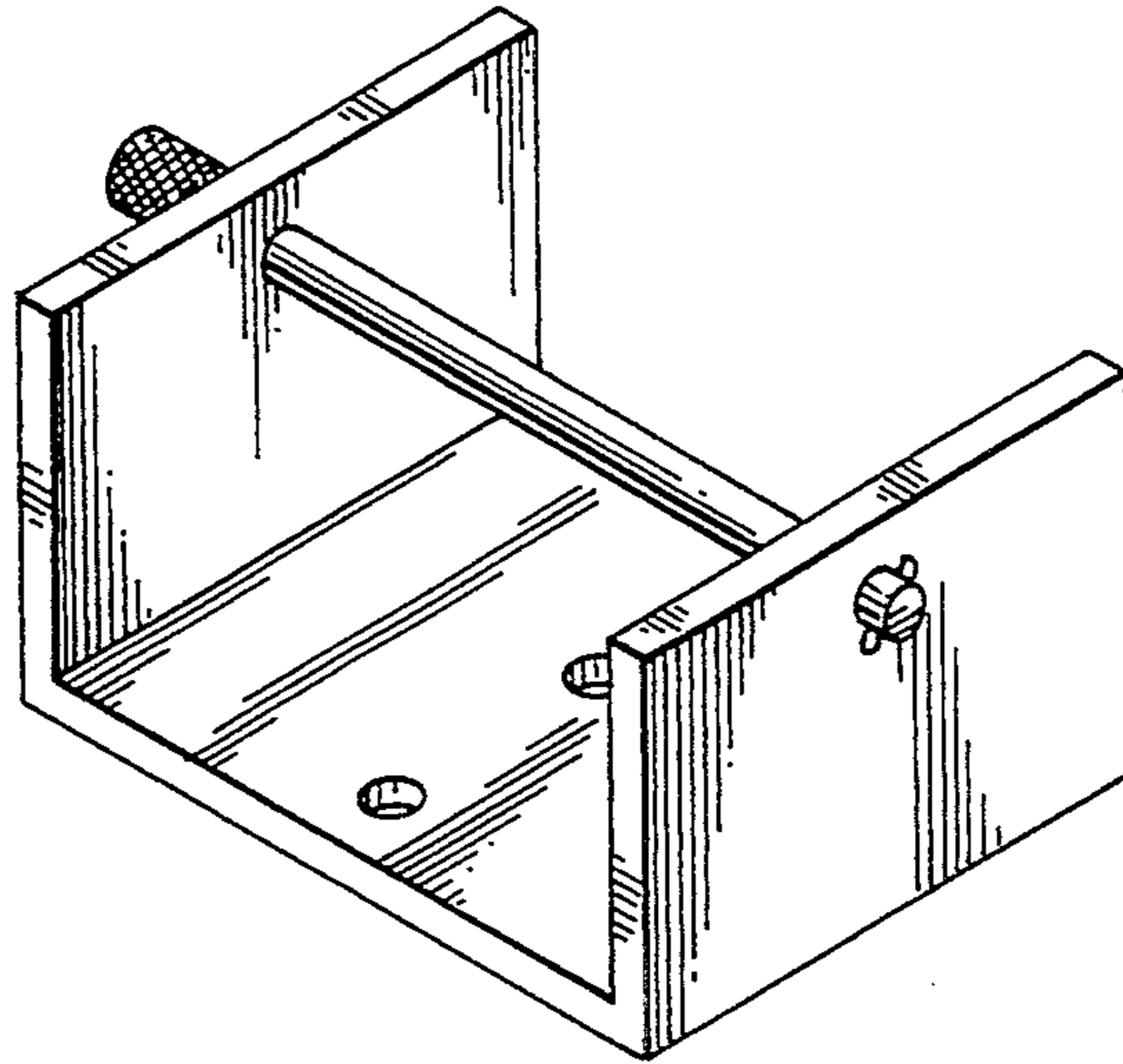

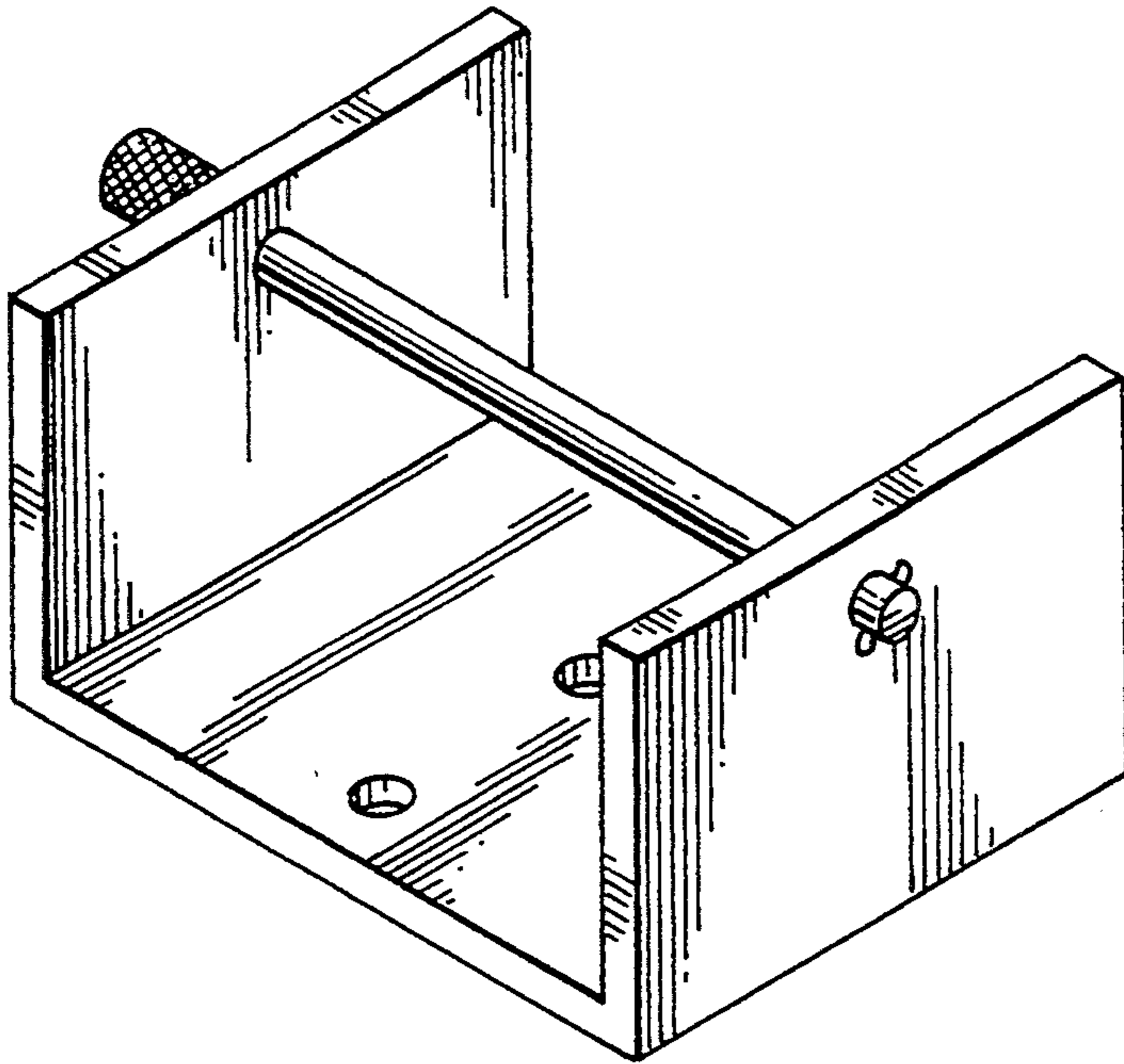

Fig. 1

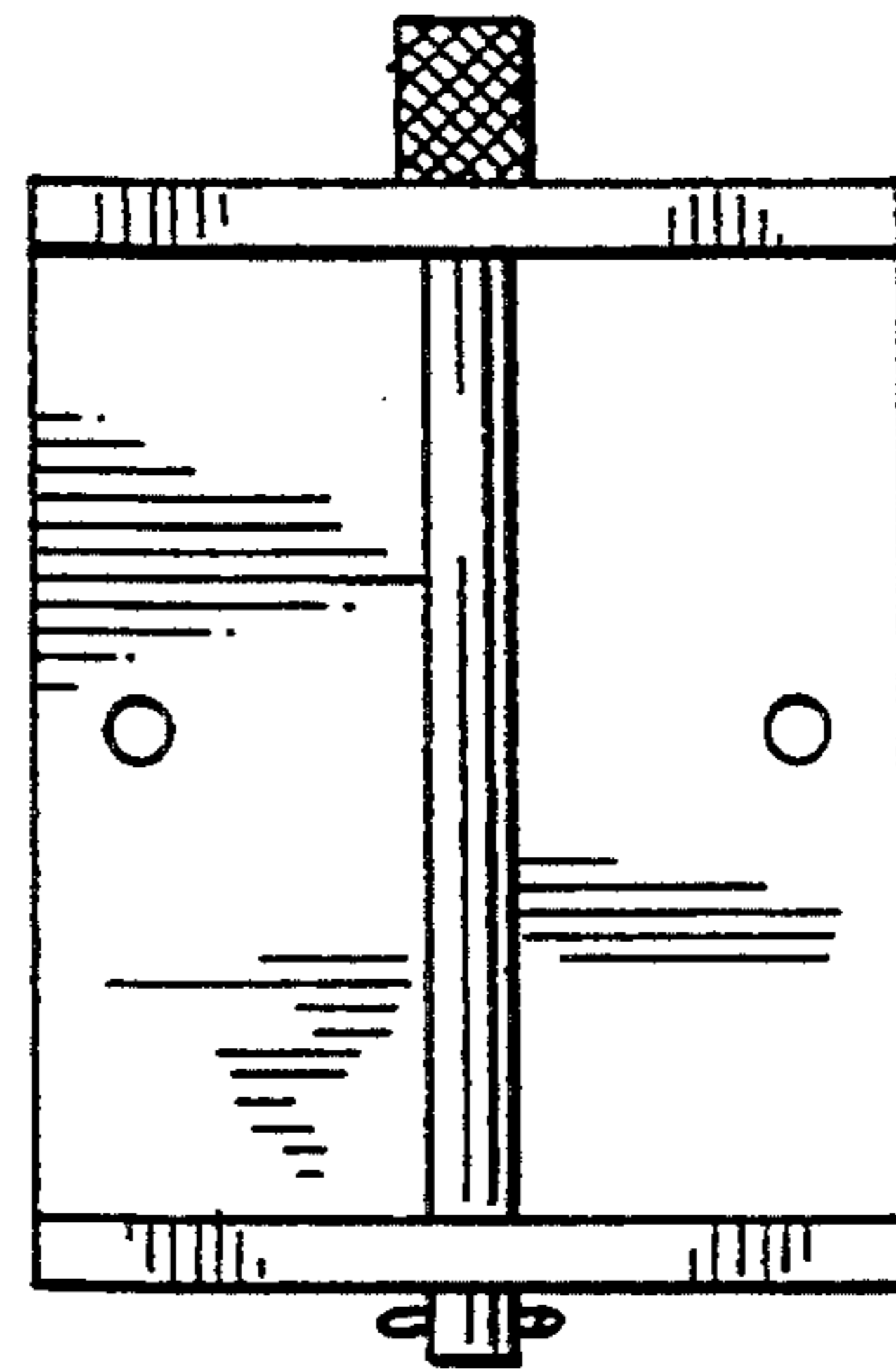

Fig. 2

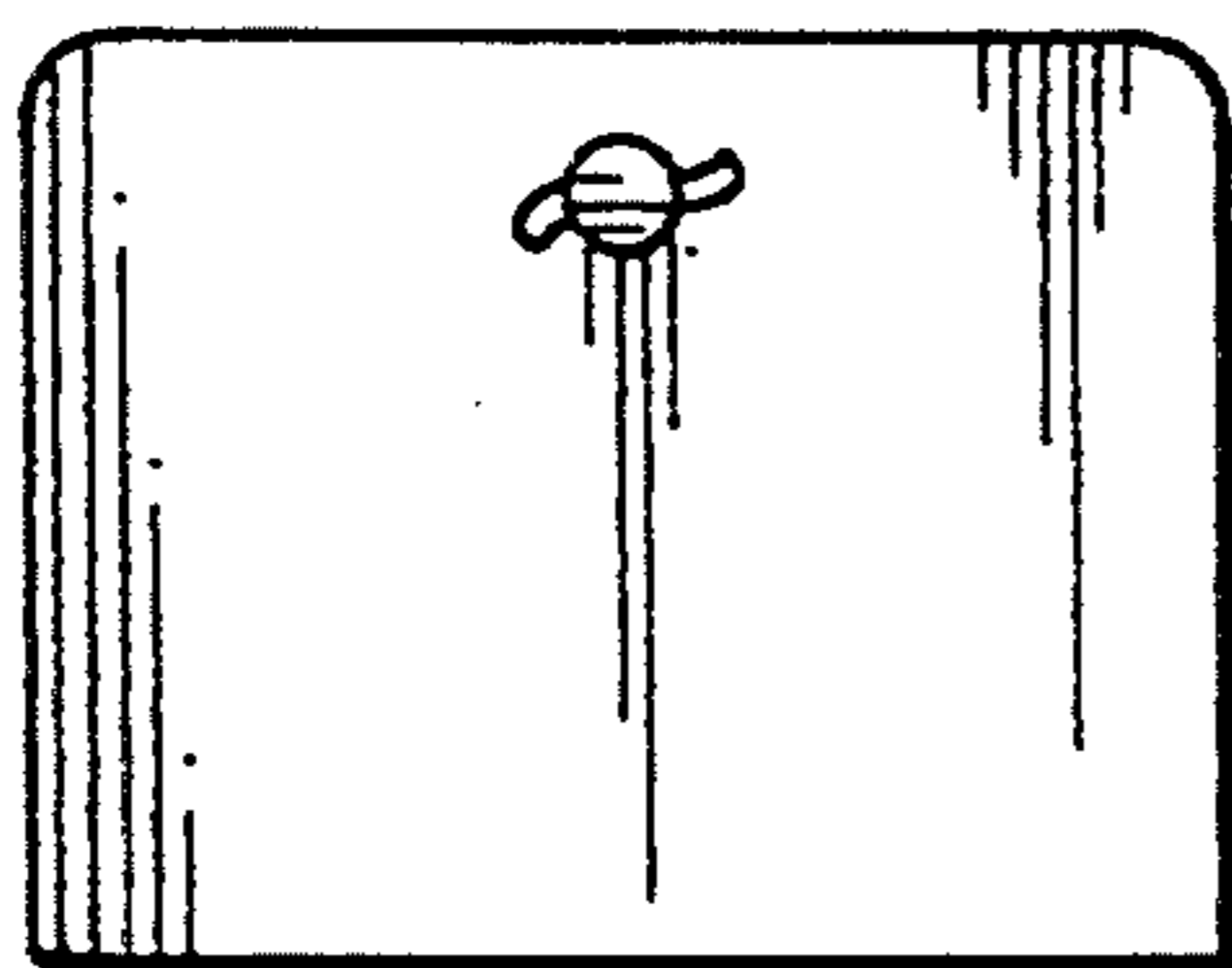

Fig. 3

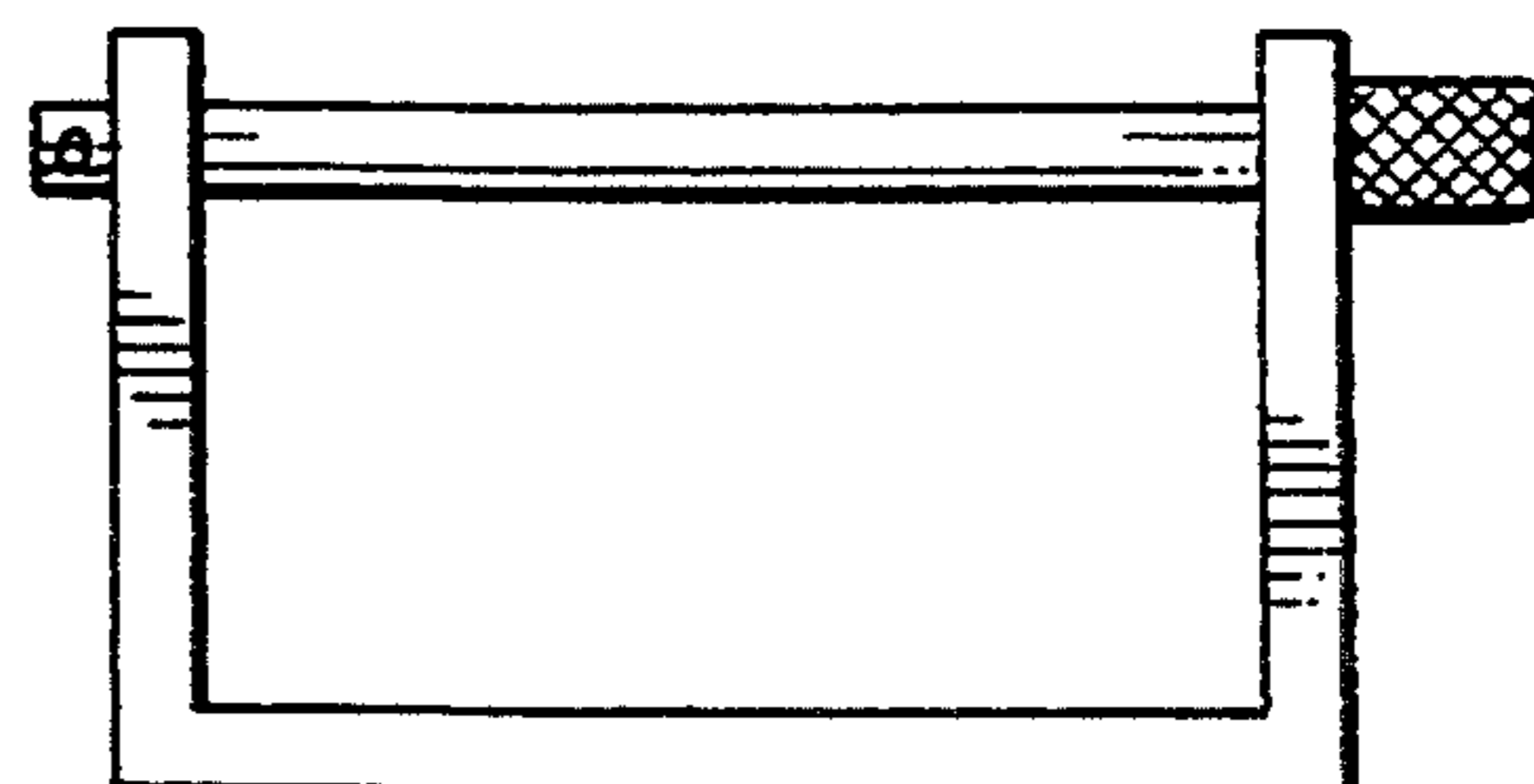

Fig. 4

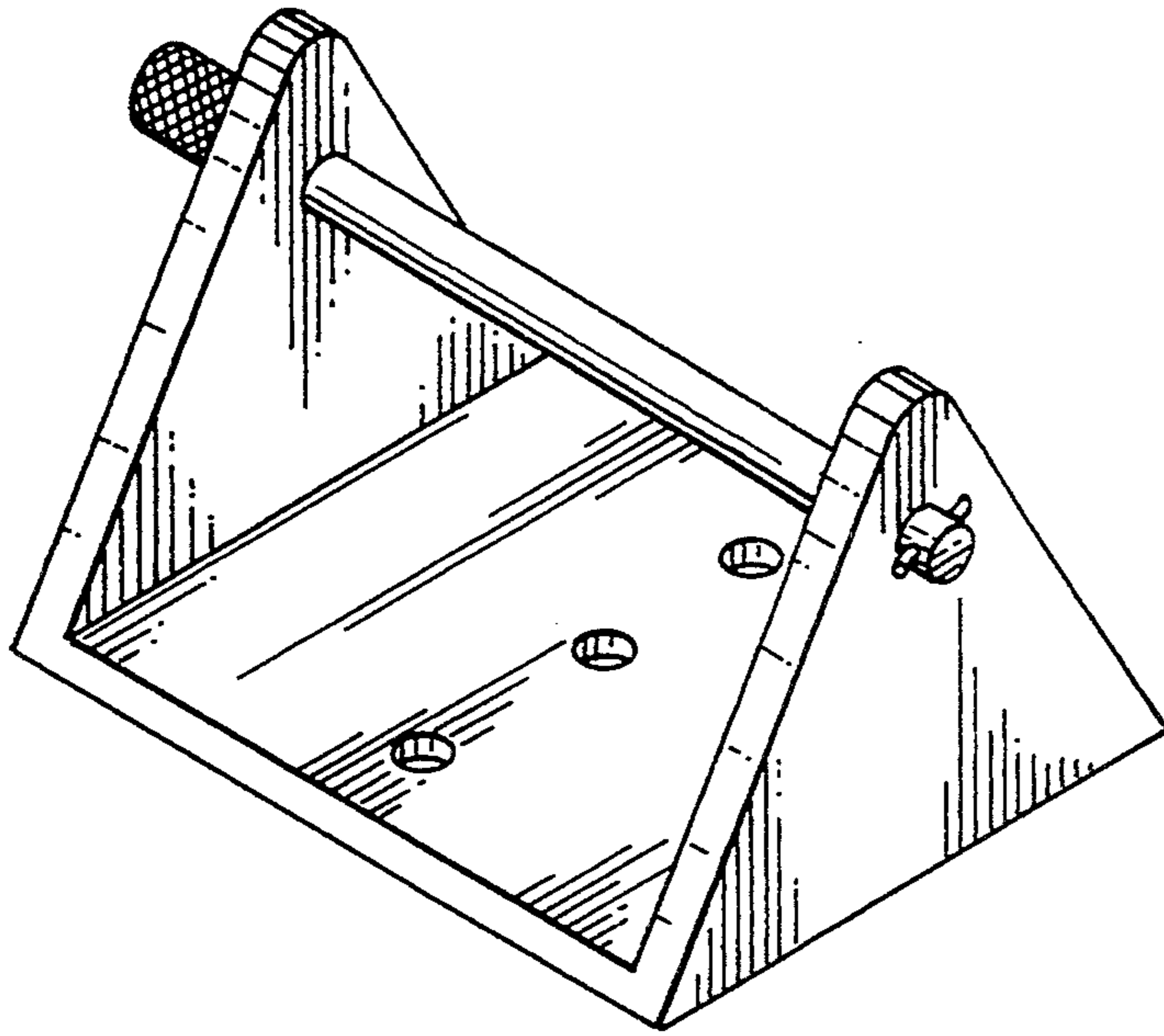

Fig. 5

Fig. 6

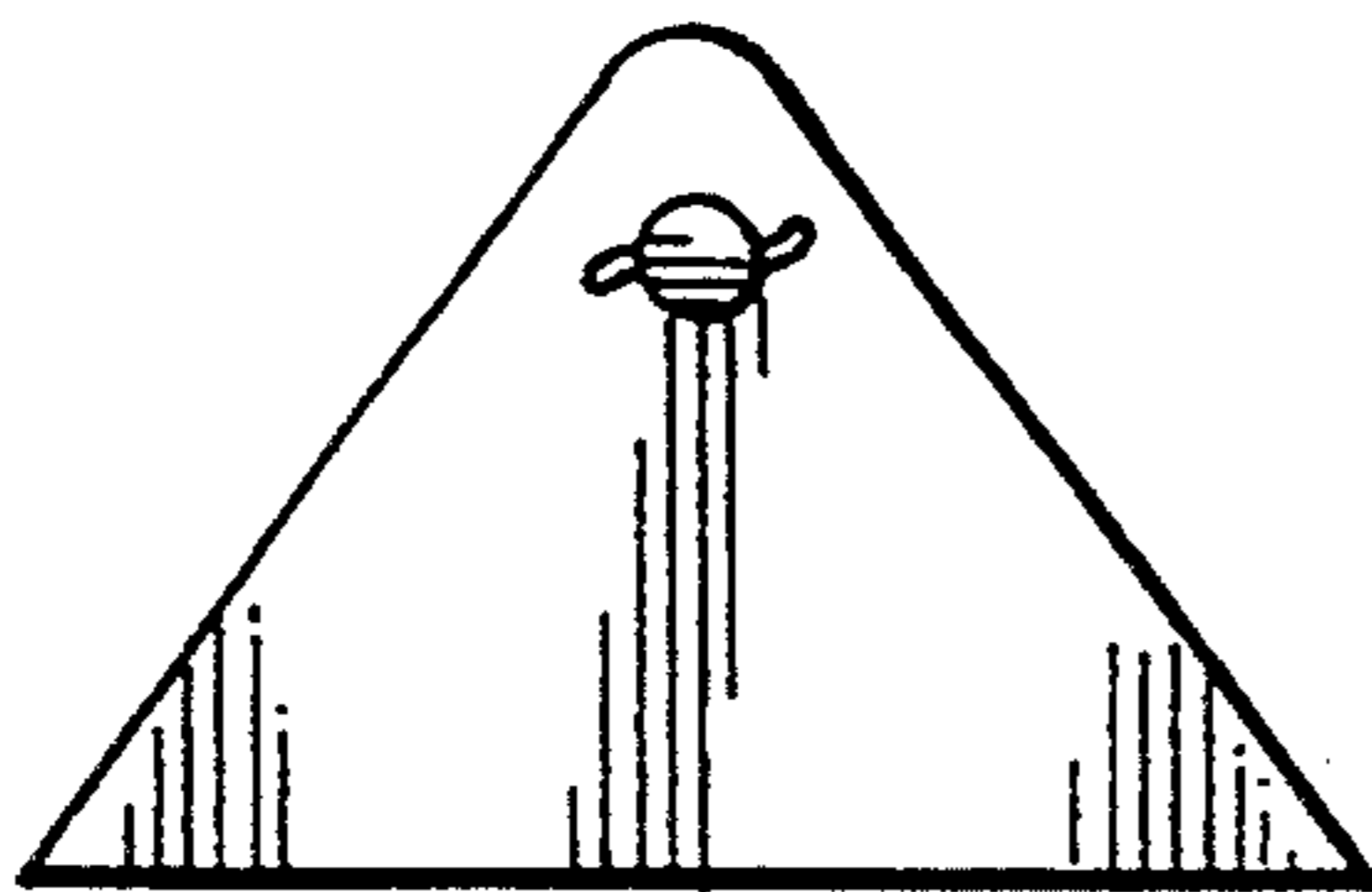
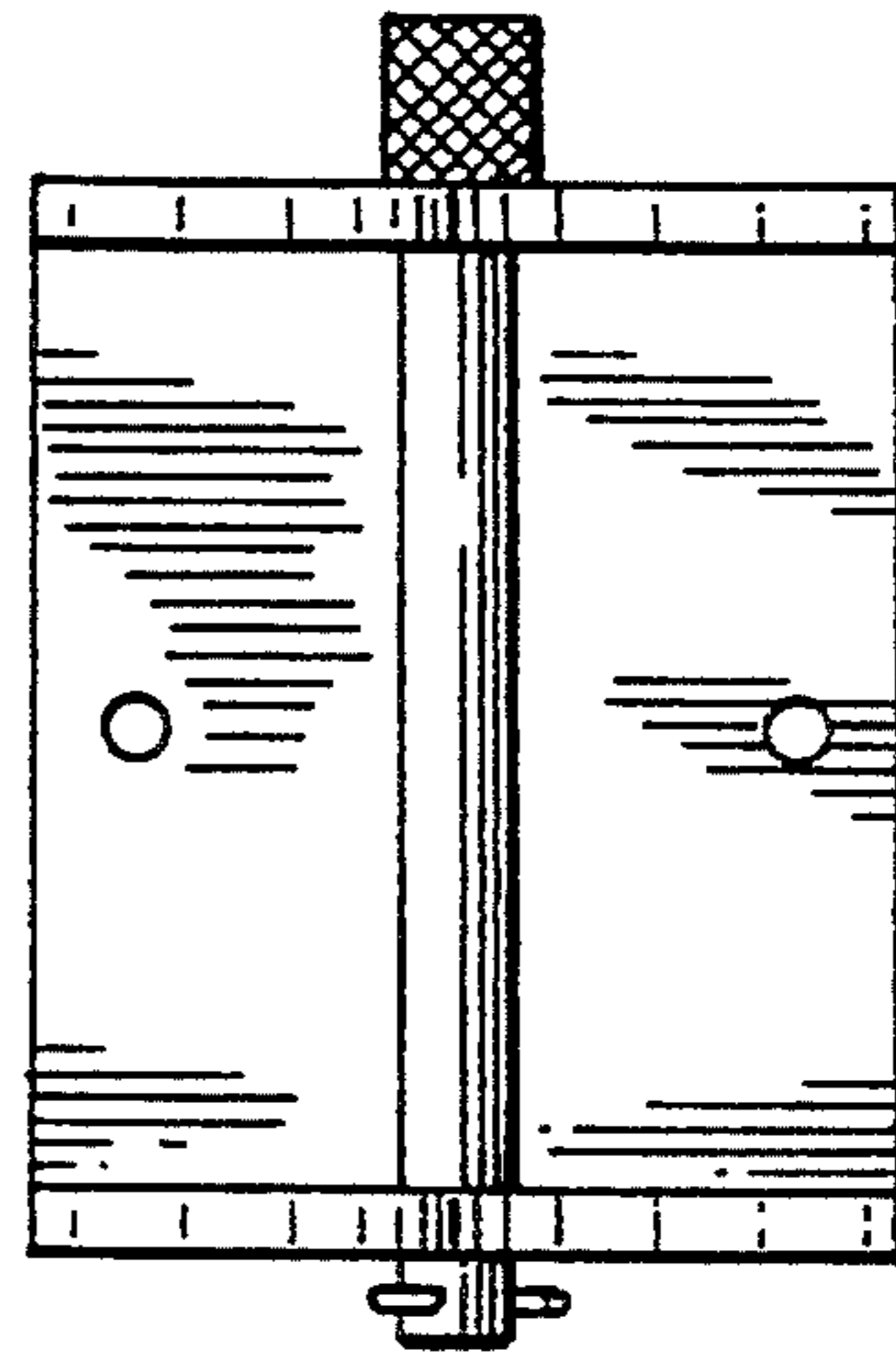

Fig. 7

Fig. 8

