



US00D359149S

United States Patent [19]

[11] Patent Number: **Des. 359,149**

Nozaki

[45] Date of Patent: **** Jun. 6, 1995**

[54] RAIL FOR A LINEAR MOTOR DRIVEN CONVEYANCE DEVICE FOR CONVEYING SMALL THINGS

[75] Inventor: **Takashi Nozaki**, Ise, Japan

[73] Assignee: **Shinko Electric Co., Ltd.**, Tokyo, Japan

[**] Term: **14 Years**

[21] Appl. No.: **19,132**

[22] Filed: **Feb. 23, 1994**

[30] Foreign Application Priority Data

Aug. 27, 1993 [JP] Japan 5-26171 U

[52] U.S. Cl. **D34/29**

[58] Field of Search D25/119, 125, 38-45; 198/618, 619, 860.1, 789, 790, 860.2, 860.3; D34/30, 35, 29

[56] References Cited

U.S. PATENT DOCUMENTS

D. 309,817	8/1990	Burkett	D34/29
D. 317,205	5/1991	Johansson	D25/38
3,788,451	1/1974	Cahn	198/618
5,029,697	7/1991	McMillan et al.	198/860.2
5,186,314	2/1993	Clopton	198/860.1
5,209,342	5/1993	vom Stein	198/790

FOREIGN PATENT DOCUMENTS

5-014289	1/1993	Japan	.
5-206851	7/1993	Japan	.
5-206852	7/1993	Japan	.
5-212095	8/1993	Japan	.
5-212096	8/1993	Japan	.
5-235884	8/1993	Japan	.
5-255253	9/1993	Japan	.
5-255254	9/1993	Japan	.

Primary Examiner—Doris Clark
Attorney, Agent, or Firm—Thompson Hine & Flory

[57] CLAIM

The ornamental design for a rail for a linear motor driven conveyance device for conveying small things, as shown and described.

DESCRIPTION

FIG. 1 is a perspective view showing my new design; FIG. 2 is a front elevation view thereof, showing a portion of the rail, and the design of the rail is the same along its entire length; FIG. 3 is a rear elevation view thereof; FIG. 4 is a top plan view thereof; FIG. 5 is a bottom view thereof; FIG. 6 is a left side elevation view thereof, showing an article which is 21 cm high and 3.6 cm wide. The opposite side is substantially a mirror image of that shown; and, FIG. 7 is a cross-sectional view taken along line 7—7 in FIG. 2.

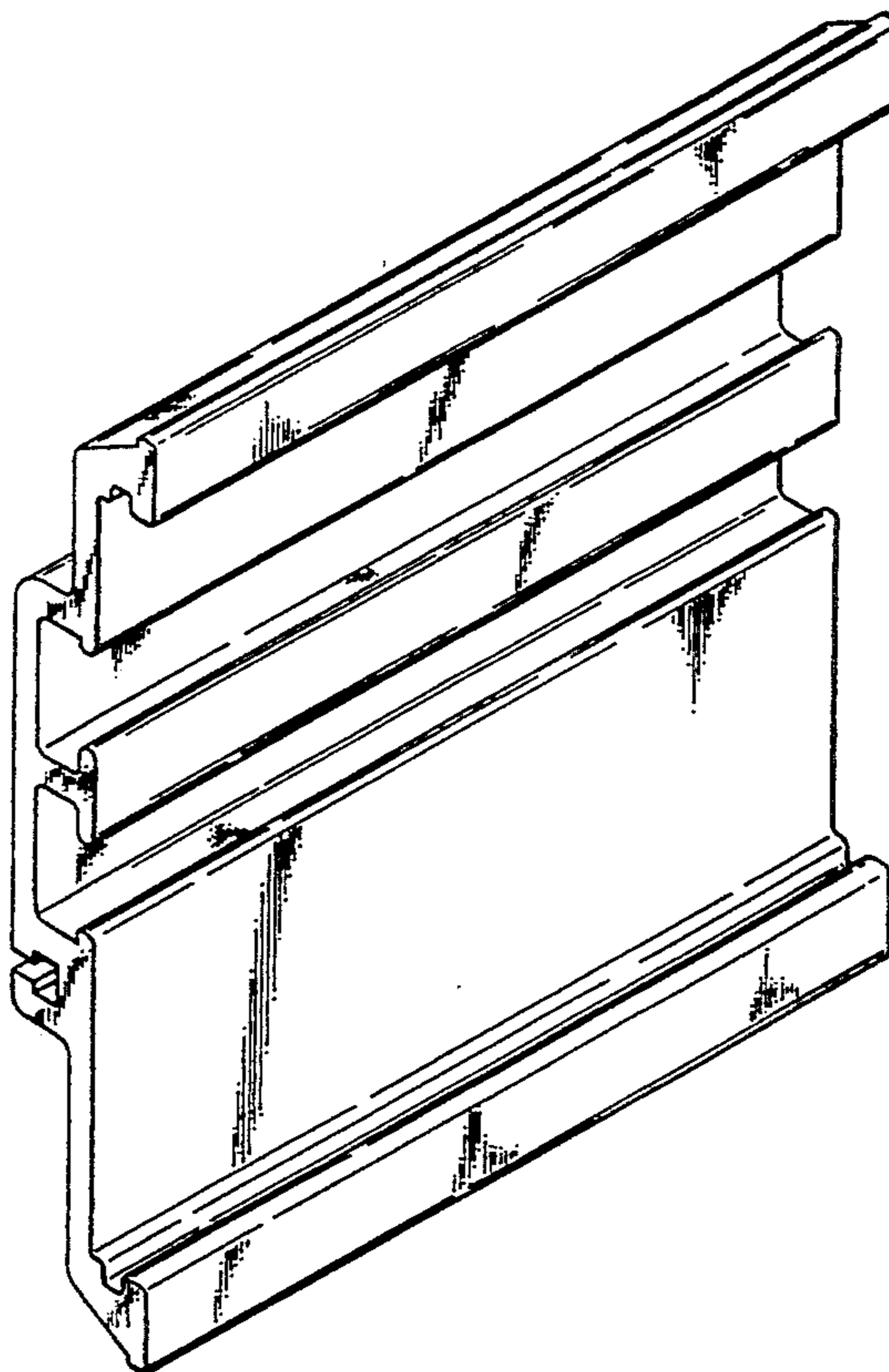

FIG. 1

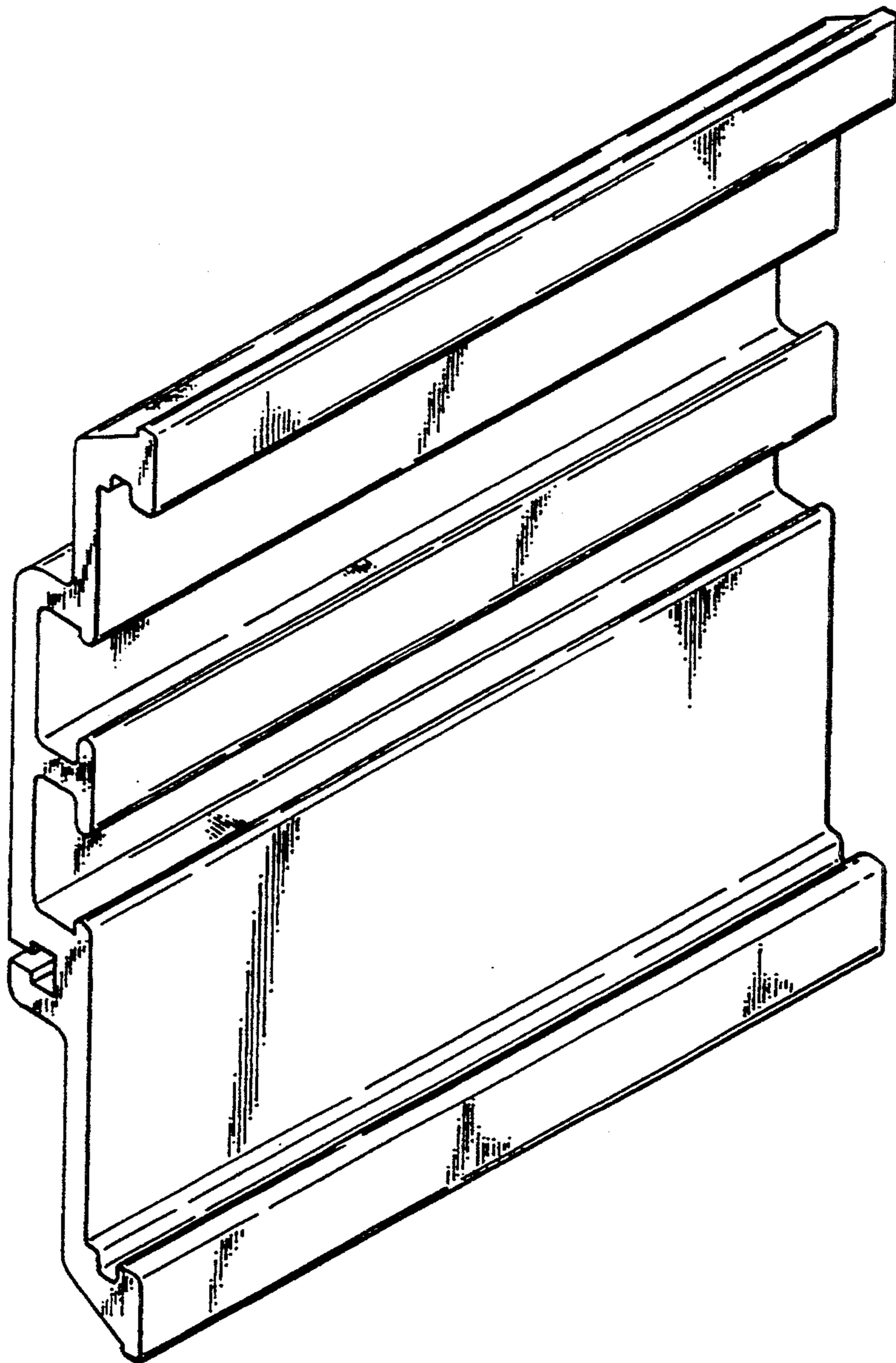
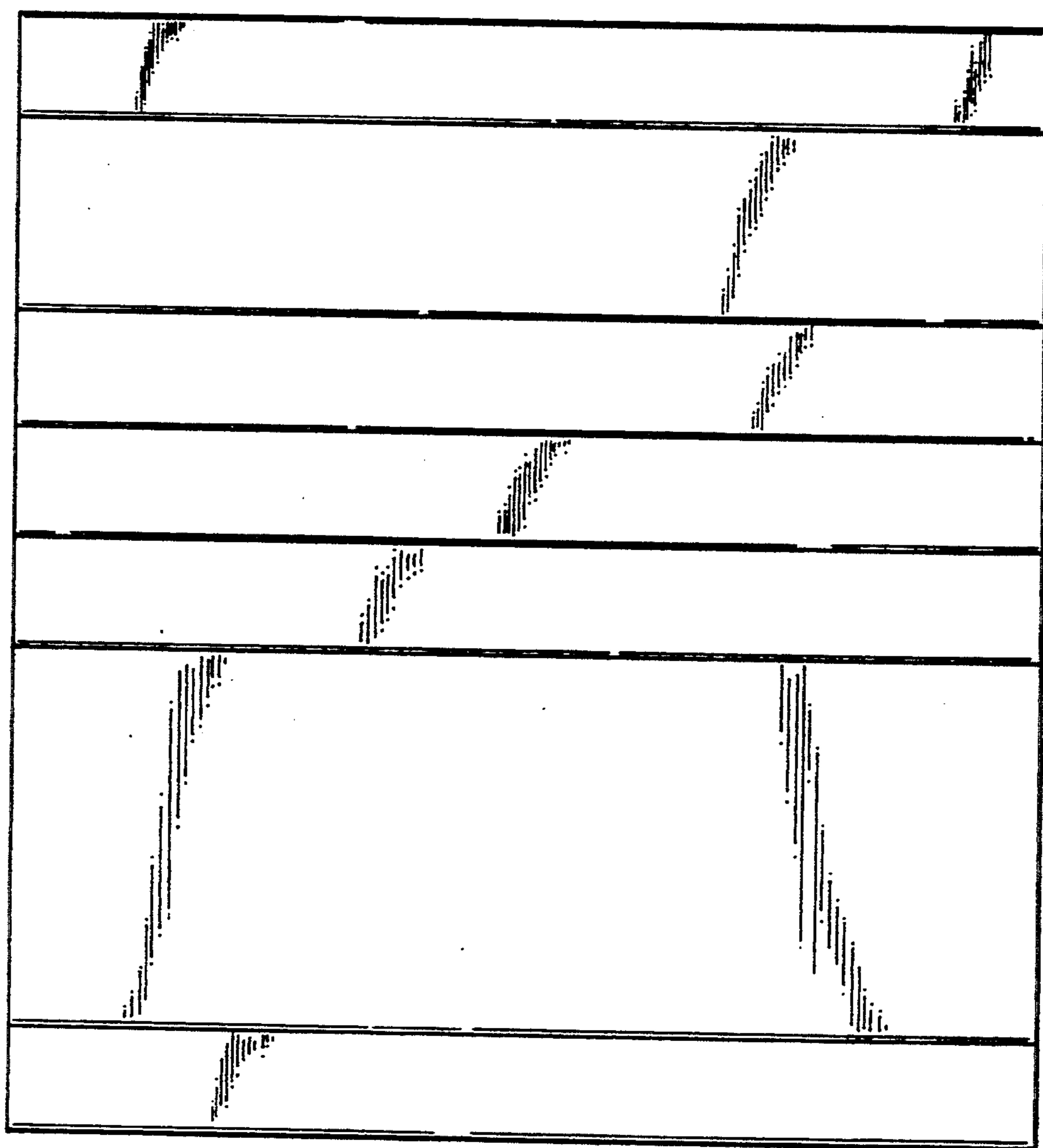

FIG.2

7



7

FIG.3

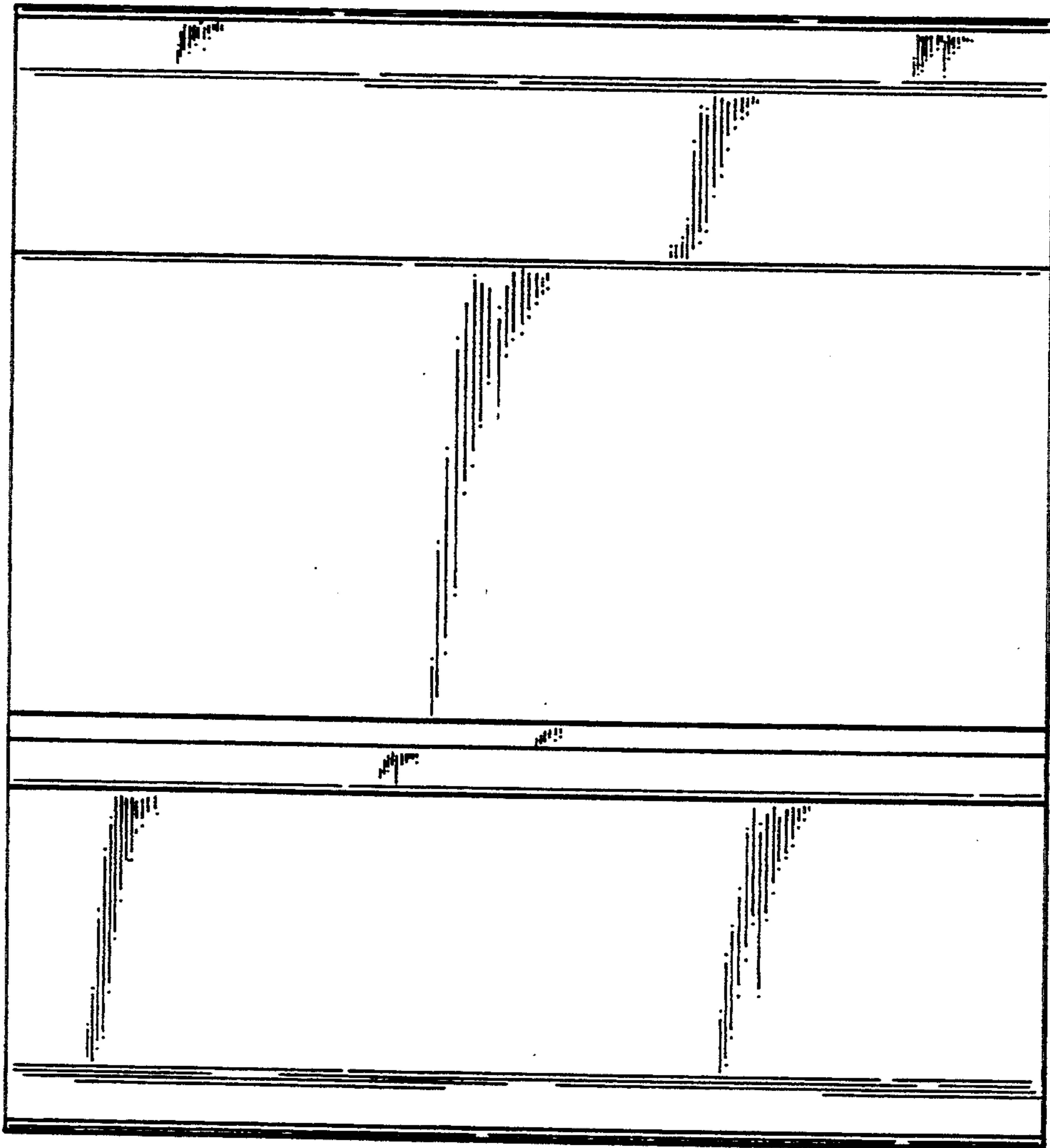

FIG.4



FIG.5

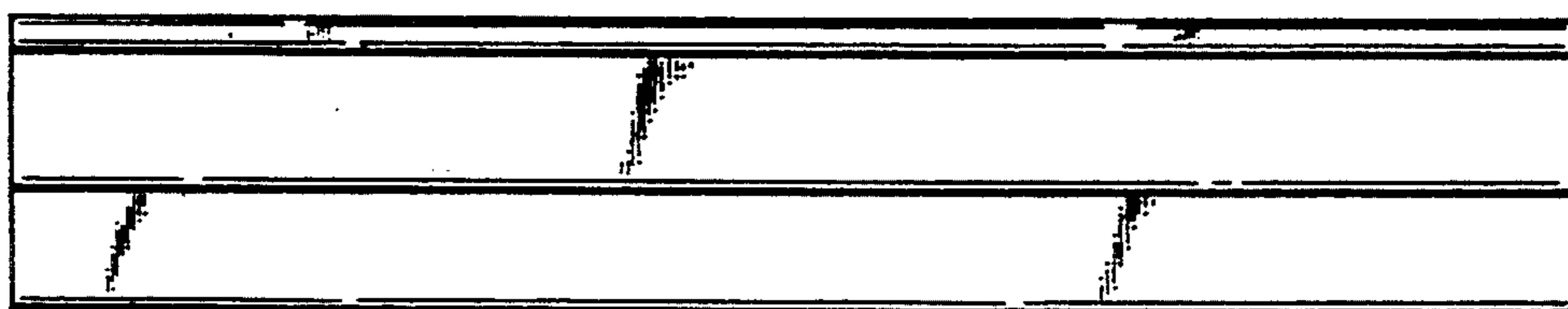

FIG. 6

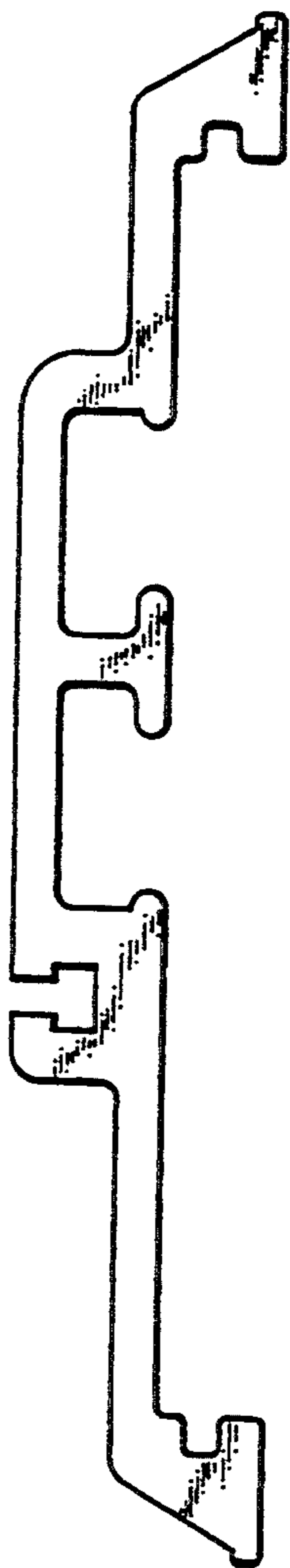

FIG. 7

