



US00D359024S

United States Patent [19]

[11] Patent Number: **Des. 359,024**

Ito

[45] Date of Patent: **** Jun. 6, 1995**

[54] DIELECTRIC FILTER

DESCRIPTION

[75] Inventor: **Kenji Ito**, Nagoya, Japan

FIG. 1 is a top plan view of a first embodiment of the piezoelectric filter of the present invention;

[73] Assignee: **NGK Spark Plug Co., Ltd.**, Aichi, Japan

FIG. 2 is a front elevation view of the piezoelectric filter depicted in FIG. 1;

[**] Term: **14 Years**

FIG. 3 is a right side elevation view of the piezoelectric filter depicted in FIG. 1;

[21] Appl. No.: **15,945**

FIG. 4 is a left side elevation view of the piezoelectric filter depicted in FIG. 1;

[22] Filed: **Dec. 2, 1993**

FIG. 5 is a bottom plan view of the piezoelectric filter depicted in FIG. 1;

[30] Foreign Application Priority Data

FIG. 6 is a rear view of the piezoelectric filter depicted in FIG. 1;

Jun. 2, 1993 [JP] Japan 5-16211

FIG. 7 is a cross-sectional view of the piezoelectric filter depicted in FIG. 1 taken along the line 7—7 in FIG. 1;

Jun. 2, 1993 [JP] Japan 5-16212

Jun. 2, 1993 [JP] Japan 5-16213

FIG. 8 is a cross-sectional view of the piezoelectric filter depicted in FIG. 2 taken along the line 8—8 in FIG. 2;

Jun. 16, 1993 [JP] Japan 5-18106

Jun. 16, 1993 [JP] Japan 5-18107

Jun. 16, 1993 [JP] Japan 5-18108

Jun. 23, 1993 [JP] Japan 5-18917

Jun. 23, 1993 [JP] Japan 5-18918

Jun. 23, 1993 [JP] Japan 5-18919

[52] U.S. Cl. **D13/123; D13/182**

FIG. 9 is a perspective view showing the upper and front side surfaces of the piezoelectric filter depicted in FIG. 1;

[58] Field of Search **D13/123, 182; 333/202, 333/204, 206, 208, 219; 174/52.1, 52.4, 260**

FIG. 10 is a perspective view showing the lower and rear surfaces of the piezoelectric filter depicted in FIG. 1;

[56] References Cited

U.S. PATENT DOCUMENTS

- 4,431,977 2/1984 Sokola et al. 333/206
- 4,703,291 10/1987 Nishikawa et al. 333/202
- 4,733,208 3/1988 Ishikawa et al. 333/202
- 4,795,992 1/1989 Saito et al. 333/202 X
- 4,806,889 2/1989 Nakano et al. 333/206 X
- 4,890,079 12/1989 Sasaki 333/202 X
- 4,965,537 10/1990 Komrmusch 333/202
- 5,208,566 5/1993 Kenoun et al. 333/206

FIG. 11 is a perspective view showing the upper and front side surfaces of the piezoelectric filter of a second embodiment of the present invention;

FIG. 12 is a perspective view showing the lower and rear surfaces of the piezoelectric filter depicted in FIG. 11;

FIG. 13 is a perspective view showing the upper and front side surfaces of the piezoelectric filter of a third embodiment of the present invention;

FIG. 14 is a perspective view showing the lower and rear surfaces of the piezoelectric filter depicted in FIG. 13;

FIG. 15 is a perspective view showing the upper and front side surfaces of the piezoelectric filter of a fourth embodiment of the present invention;

FIG. 16 is a perspective view showing the lower and rear surfaces of the piezoelectric filter depicted in FIG. 15;

FIG. 17 is a perspective view showing the upper and (Description continued on next page.)

FOREIGN PATENT DOCUMENTS

- 563987 10/1993 European Pat. Off. 333/206
- 405152803 6/1993 Japan 333/204

Primary Examiner—Joel Sincavage

Attorney, Agent, or Firm—Larson and Taylor

[57] CLAIM

The ornamental design for a piezoelectric filter, as shown and described.

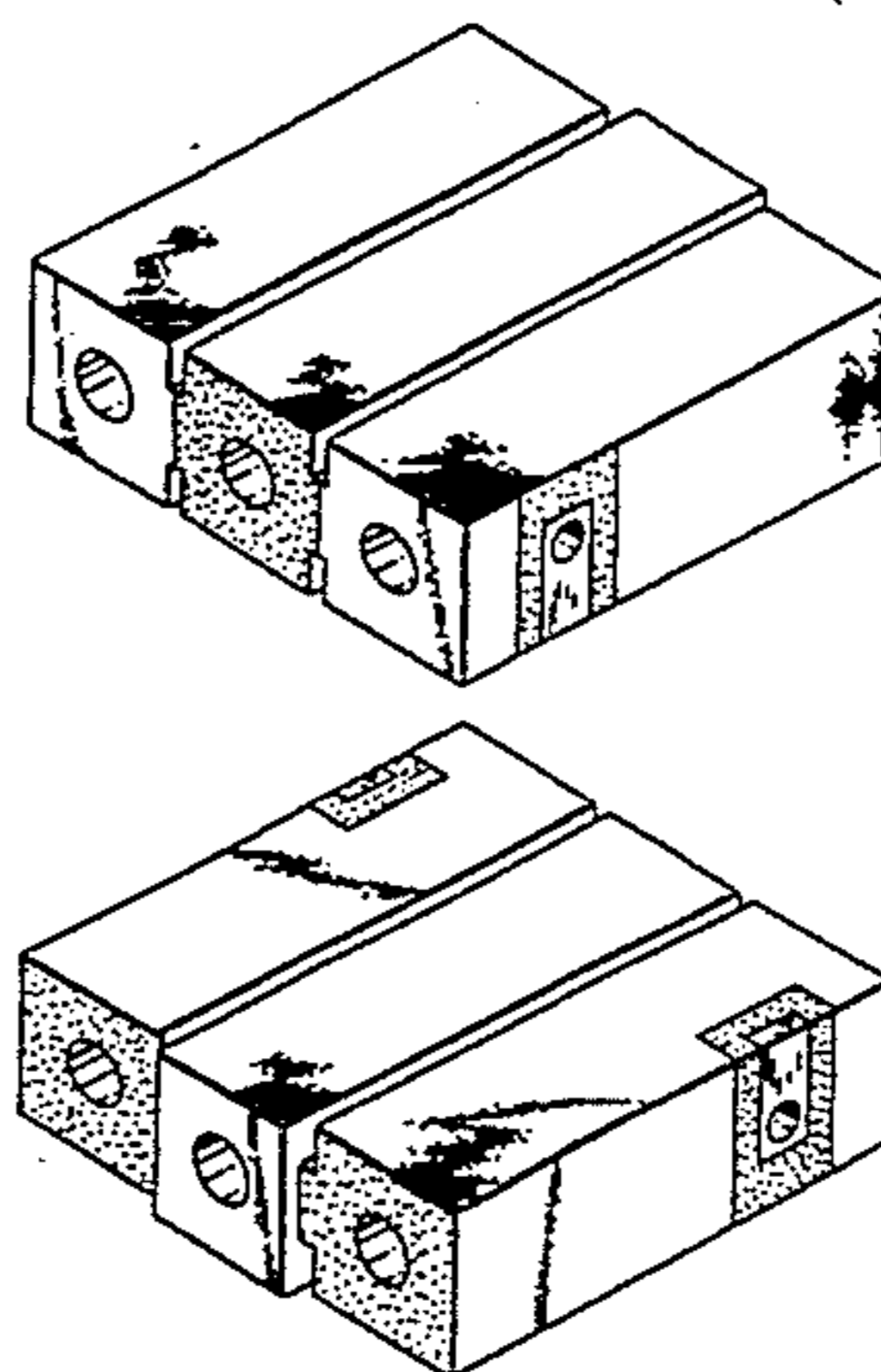

DESCRIPTION

front side surfaces of the piezoelectric filter of a fifth embodiment of the present invention;

FIG. 18 is a perspective view showing the lower and rear surfaces of the piezoelectric filter depicted in FIG. 17;

FIG. 19 is a perspective view showing the upper and front side surfaces of the piezoelectric filter of a sixth embodiment of the present invention;

FIG. 20 is a perspective view showing the lower and rear surfaces of the piezoelectric filter depicted in FIG. 19;

FIG. 21 is a perspective view showing the upper and front side surfaces of the piezoelectric filter of a seventh embodiment of the present invention;

FIG. 22 is a perspective view showing the lower and rear surfaces of the piezoelectric filter depicted in FIG. 21;

FIG. 23 is a perspective view showing the upper and front side surfaces of the piezoelectric filter of an eighth embodiment of the present invention;

FIG. 24 is a perspective view showing the lower and rear surfaces of the piezoelectric filter depicted in FIG. 23;

FIG. 25 is a perspective view showing the upper and front side surfaces of the piezoelectric filter of a ninth embodiment of the present invention;

FIG. 26 is a perspective view showing the lower and rear surfaces of the piezoelectric filter depicted in FIG. 25;

FIG. 27 is a top view of a tenth embodiment of the piezoelectric filter of the present invention;

FIG. 28 is a front elevation view of the piezoelectric filter depicted in FIG. 27;

FIG. 29 is a side elevation view of the piezoelectric filter depicted in FIG. 27;

FIG. 30 is a bottom plan view of the piezoelectric filter depicted in FIG. 27;

FIG. 31 is a rear view of the piezoelectric filter depicted in FIG. 27;

FIG. 32 is a cross-sectional view of the piezoelectric filter depicted in FIG. 27 taken along the line 32—32 in FIG. 27;

FIG. 33 is a perspective view showing the upper and front surfaces of the piezoelectric filter depicted in FIG. 27;

FIG. 34 is a perspective view showing of an eleventh embodiment of the piezoelectric filter of the present invention, the bottom, rear and left side being the same as the tenth embodiment except for the central channel on the bottom surface; and,

FIG. 35 is a perspective view showing of a twelfth embodiment of the piezoelectric filter of the present invention, the bottom, rear and left side being the same as the tenth embodiment.

FIG. 1

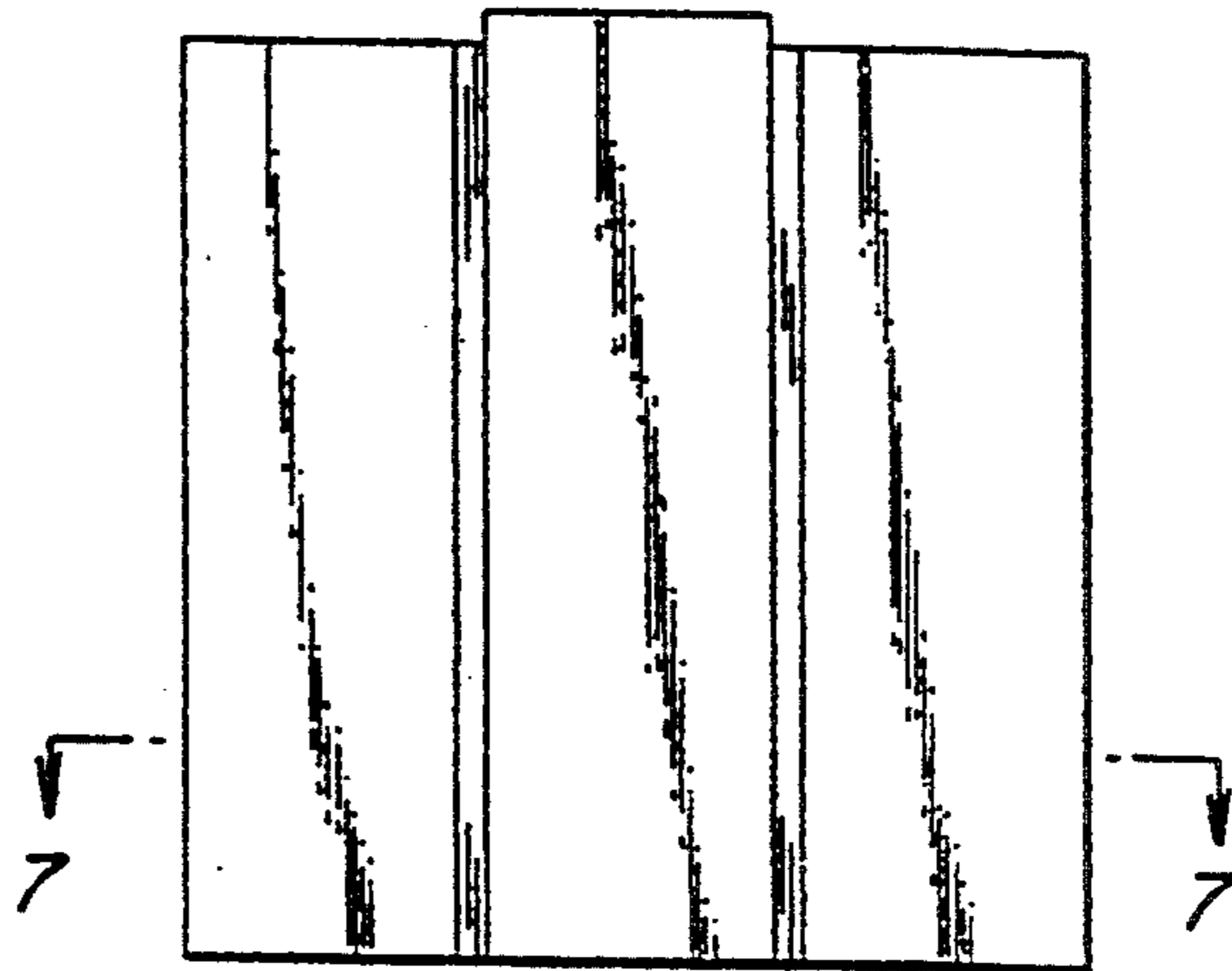

FIG. 2

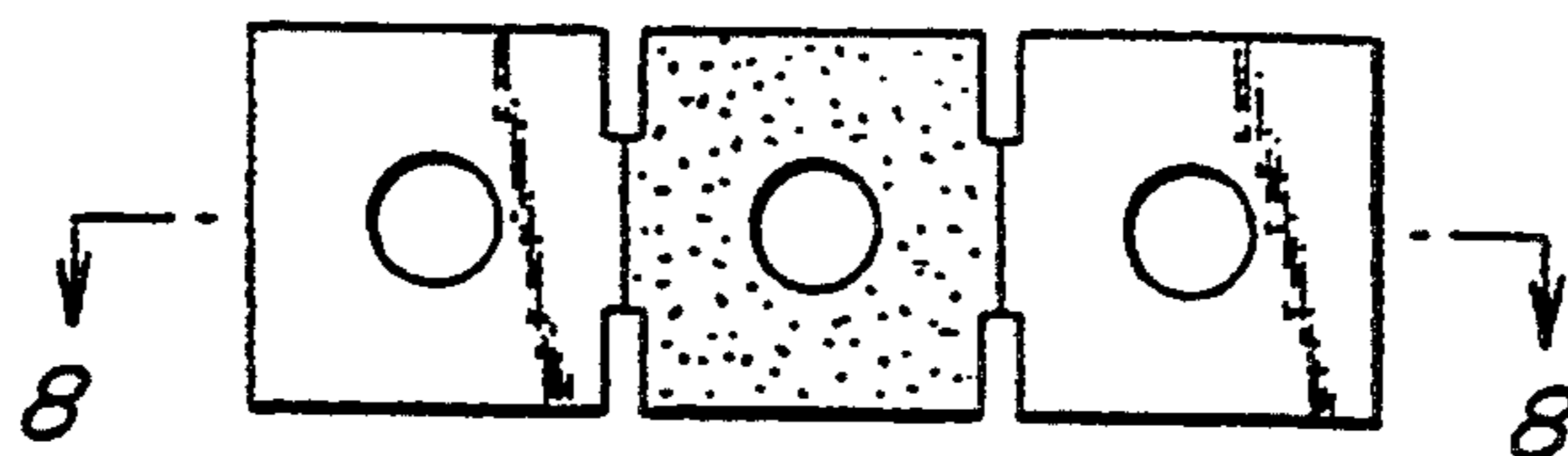

FIG. 3

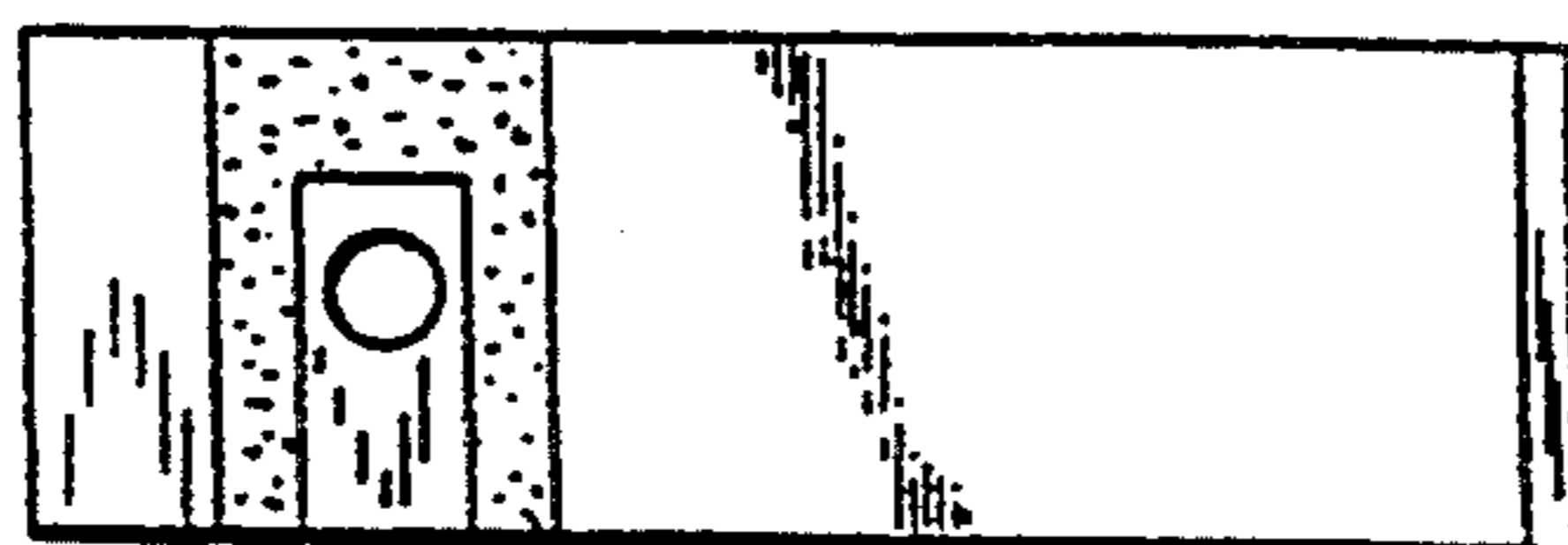

FIG. 4

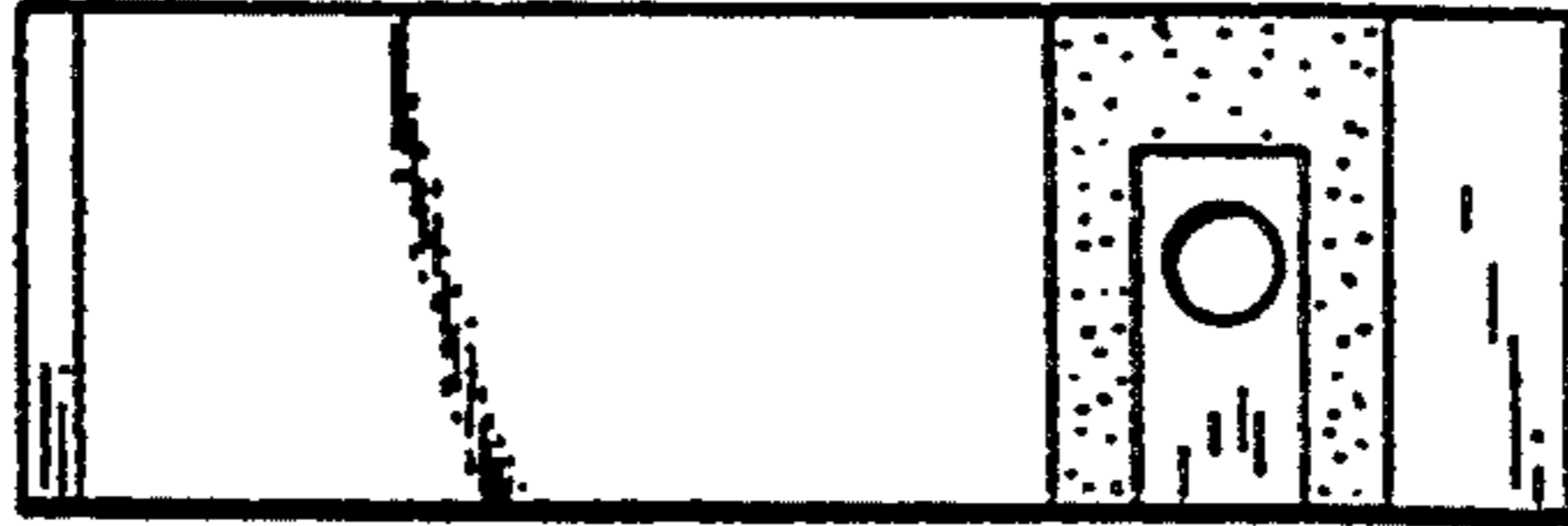

FIG. 5

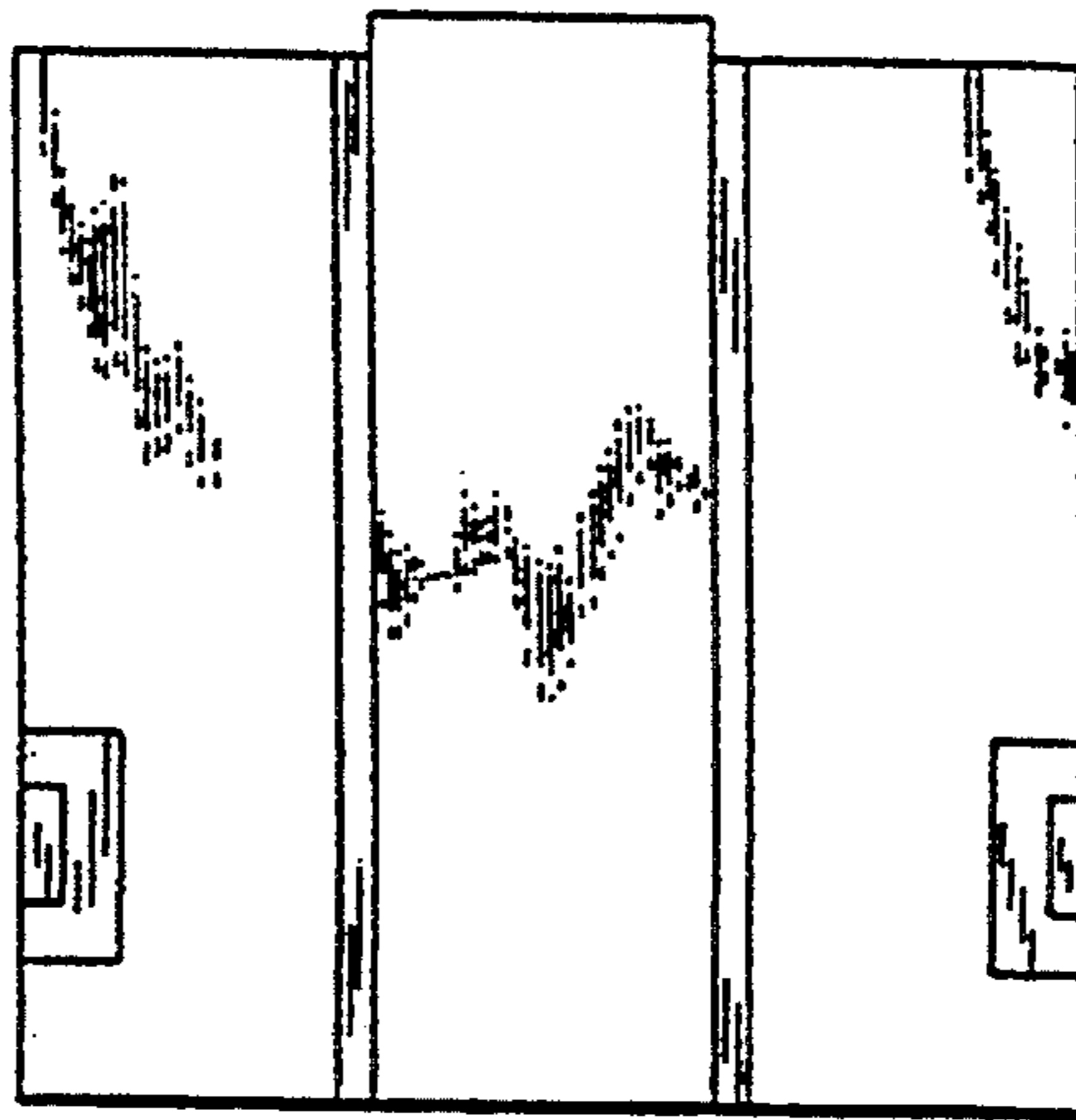

FIG. 6

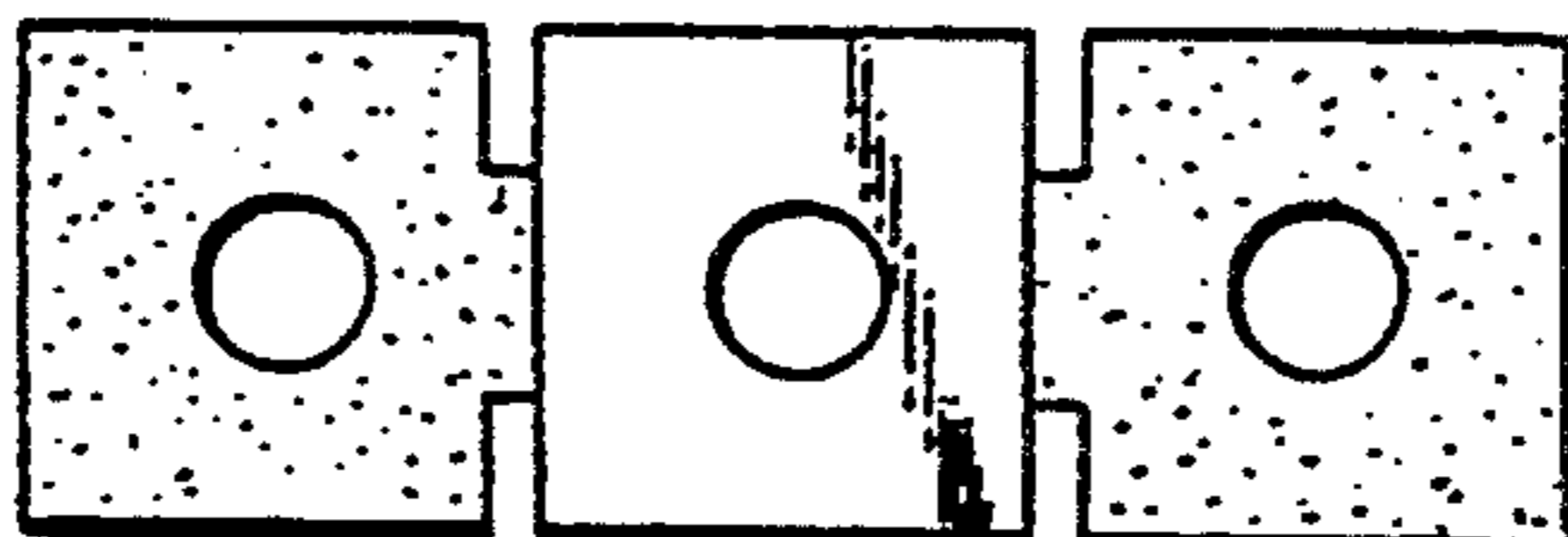

FIG. 7

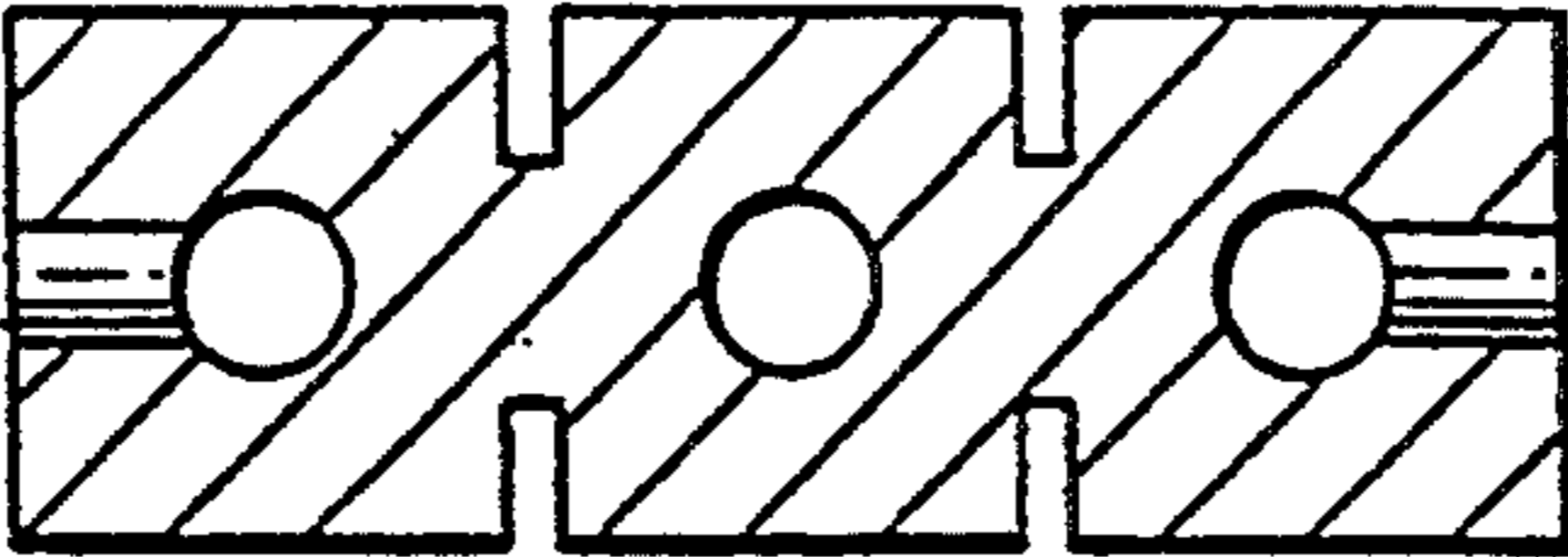

FIG. 8

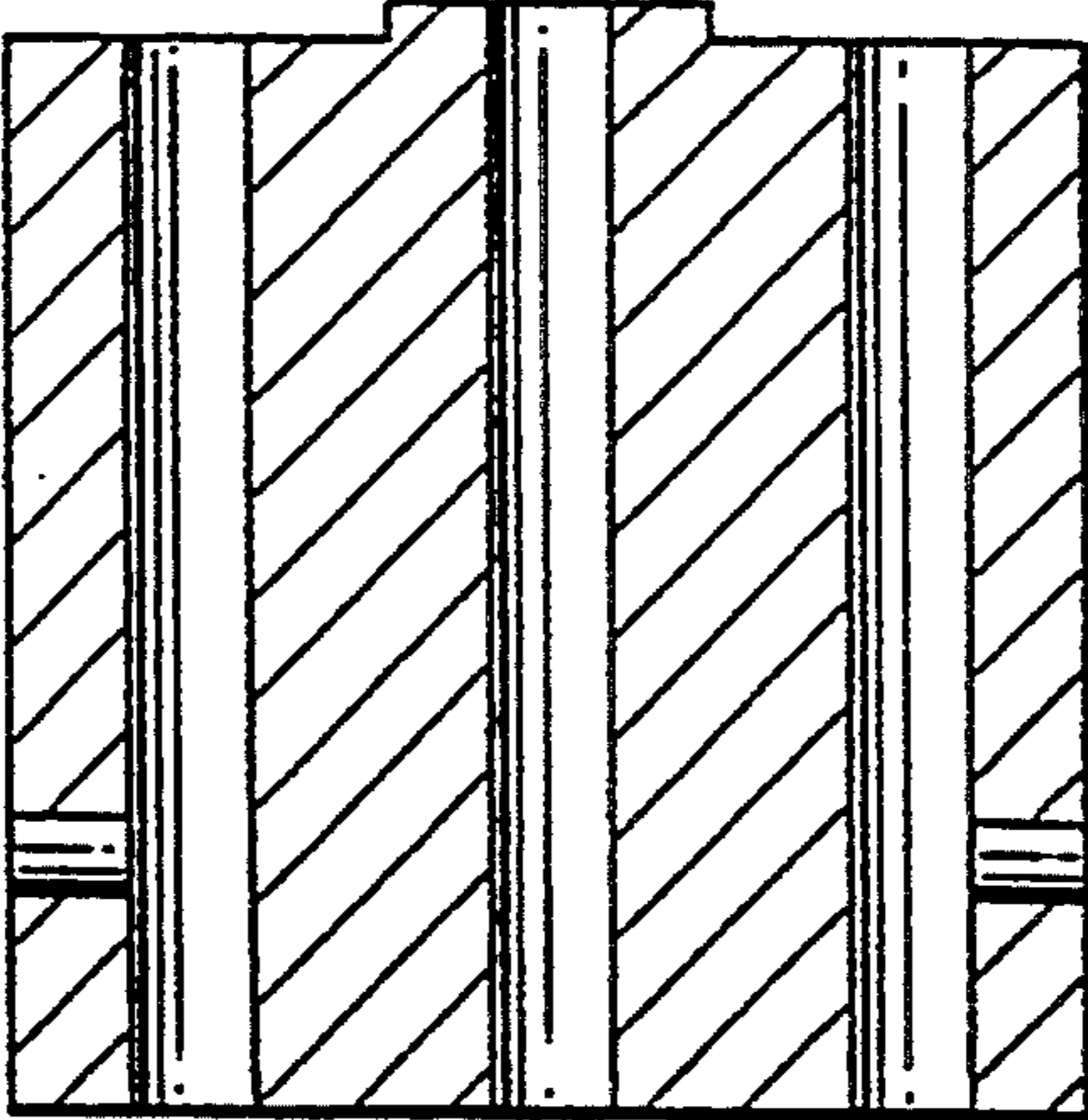

FIG. 9

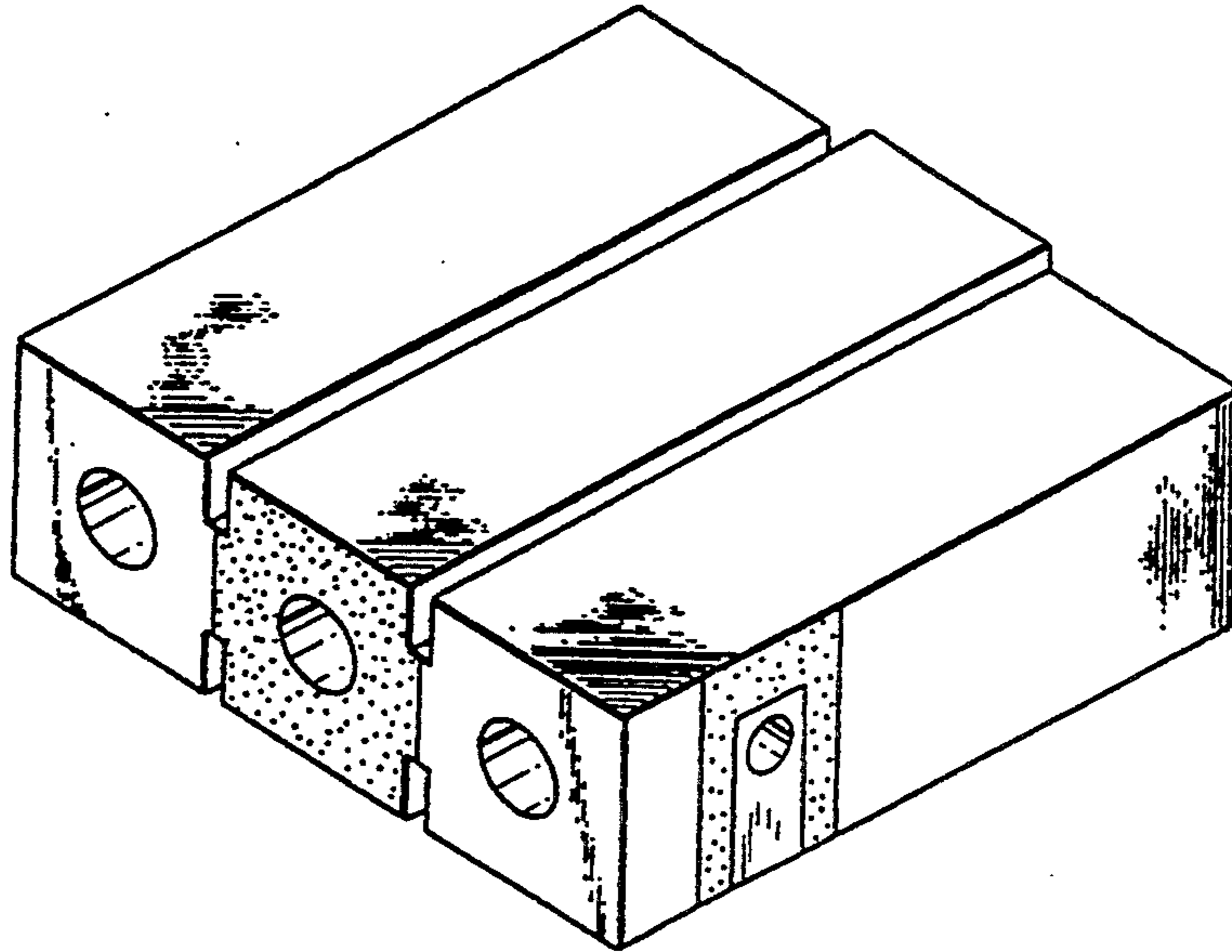

FIG. 10

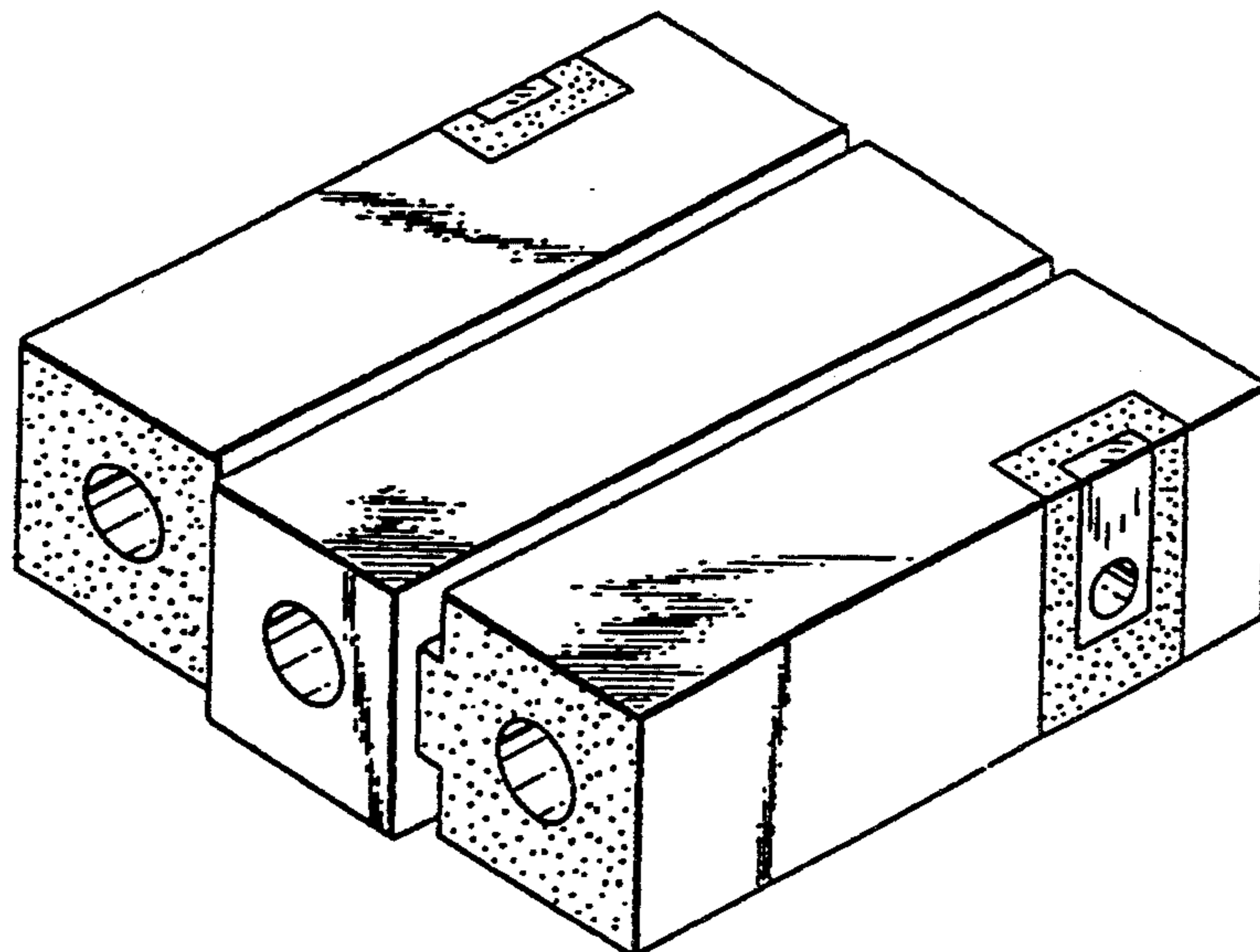

FIG. 11

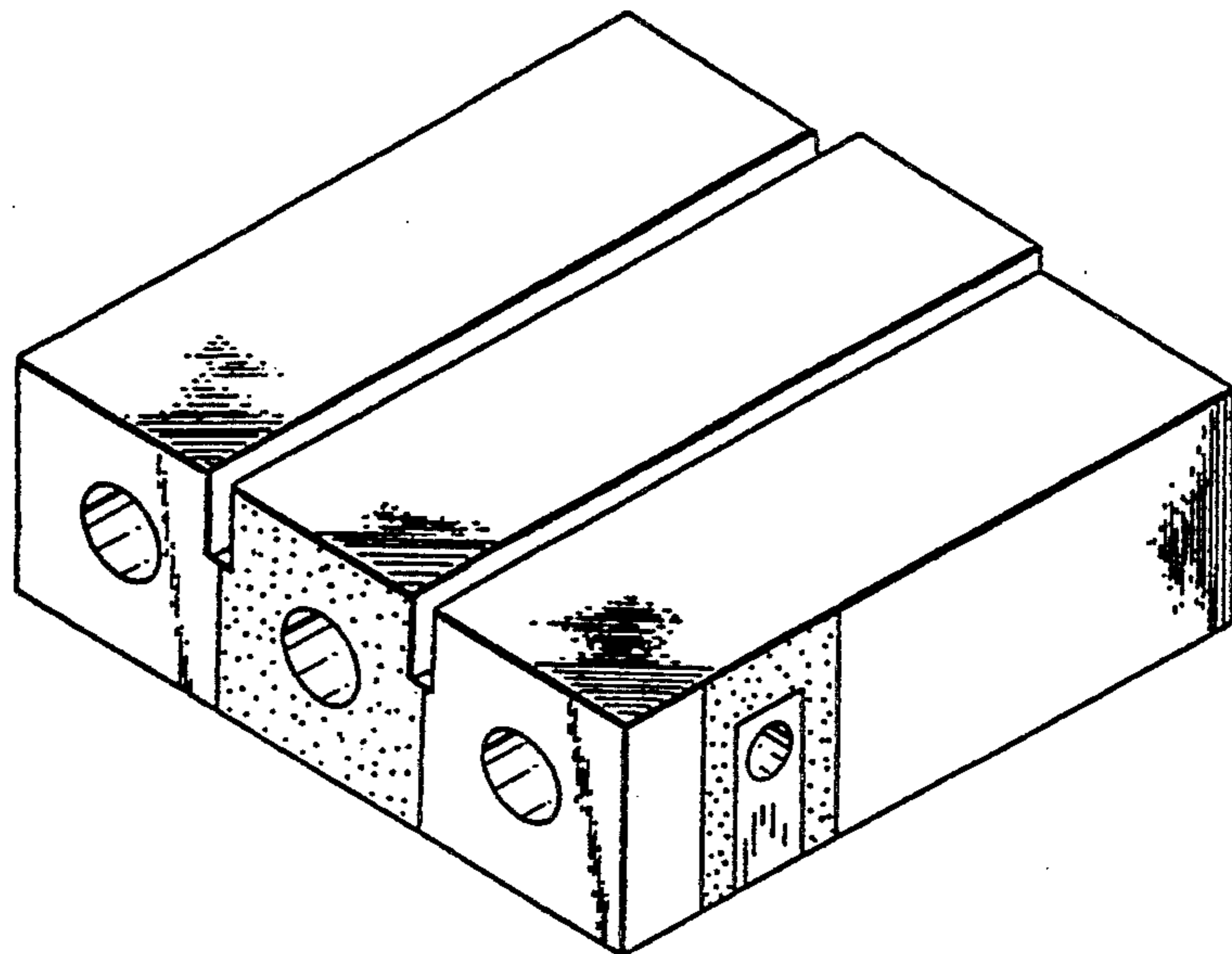

FIG. 12

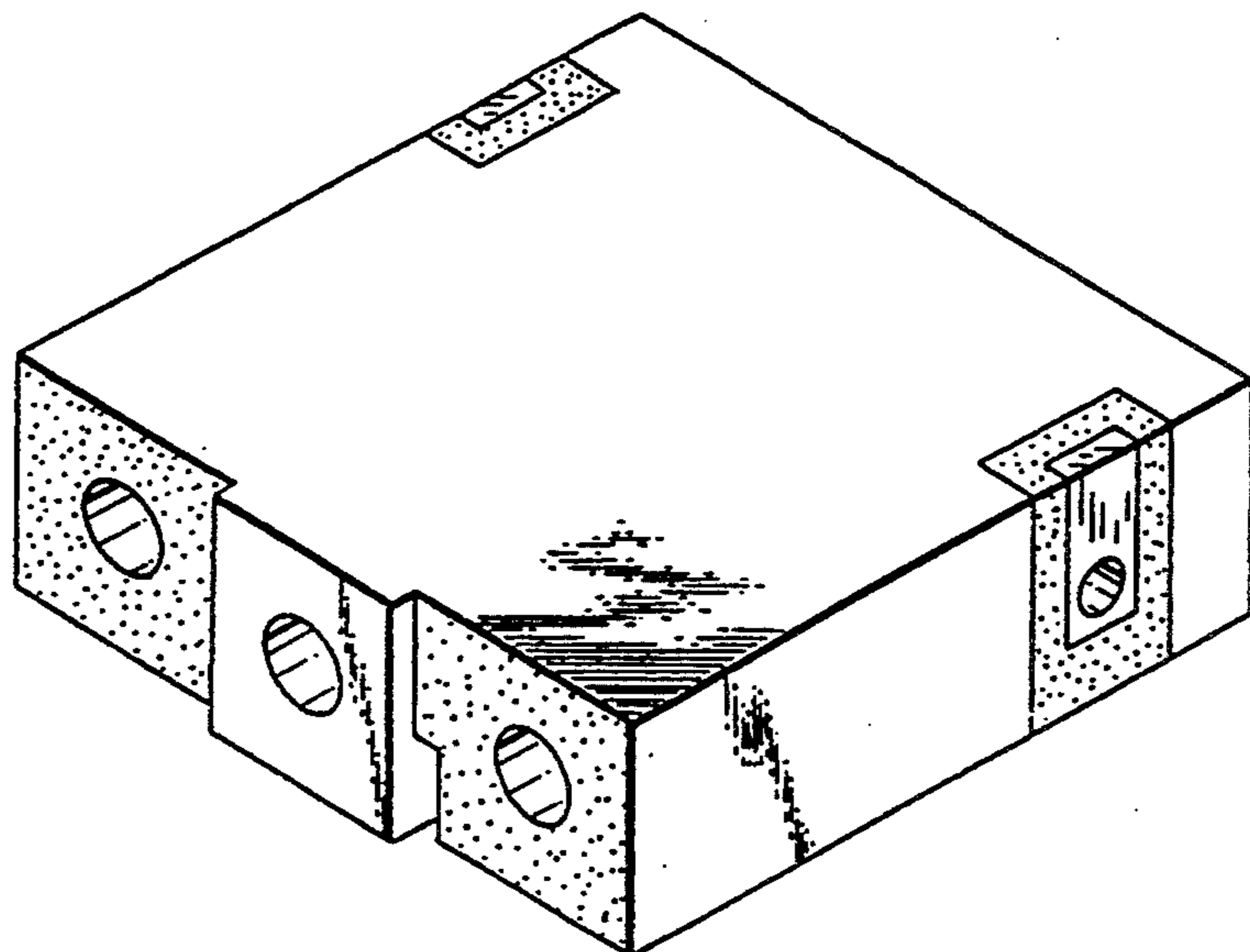

FIG. 13

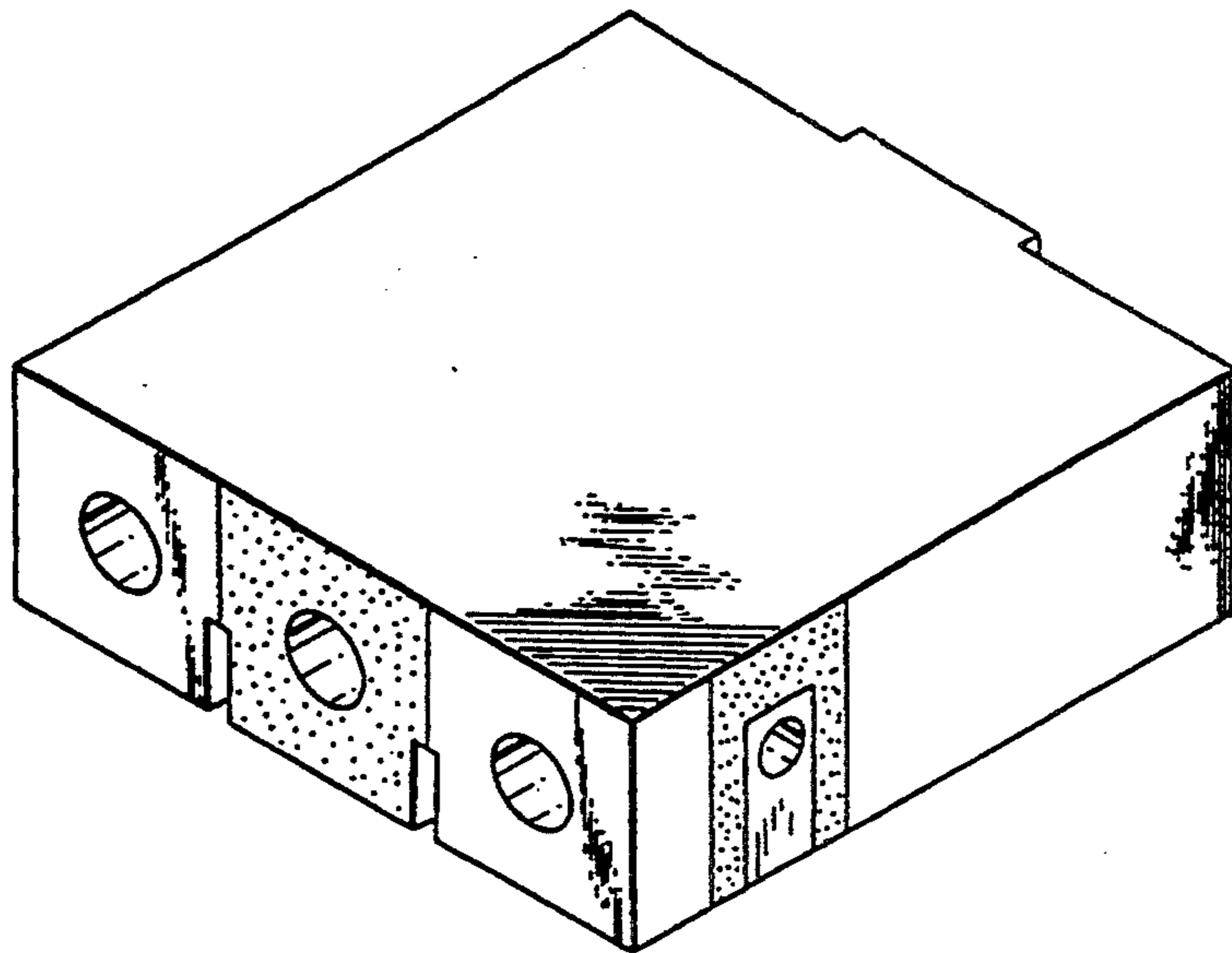

FIG. 14

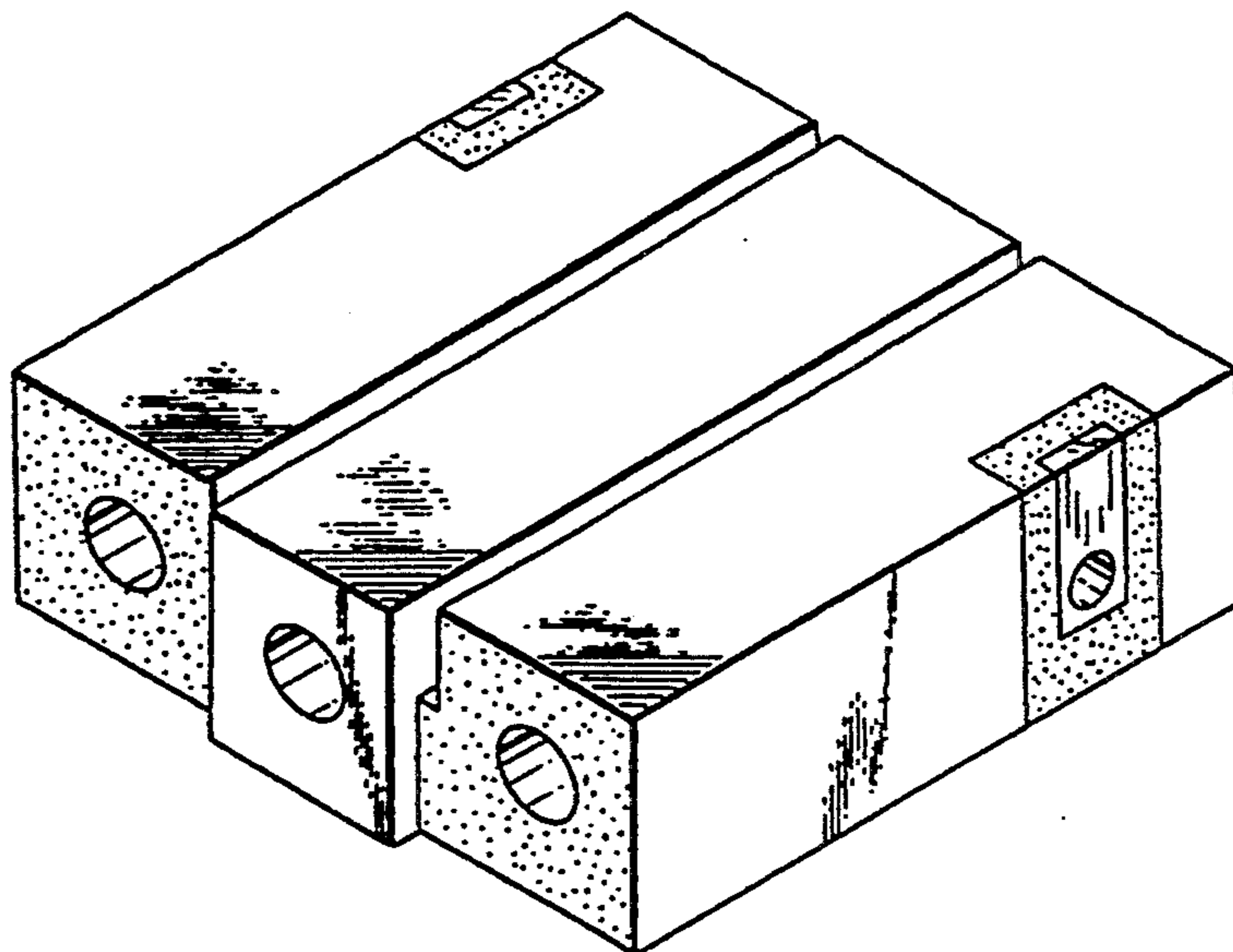

FIG. 15

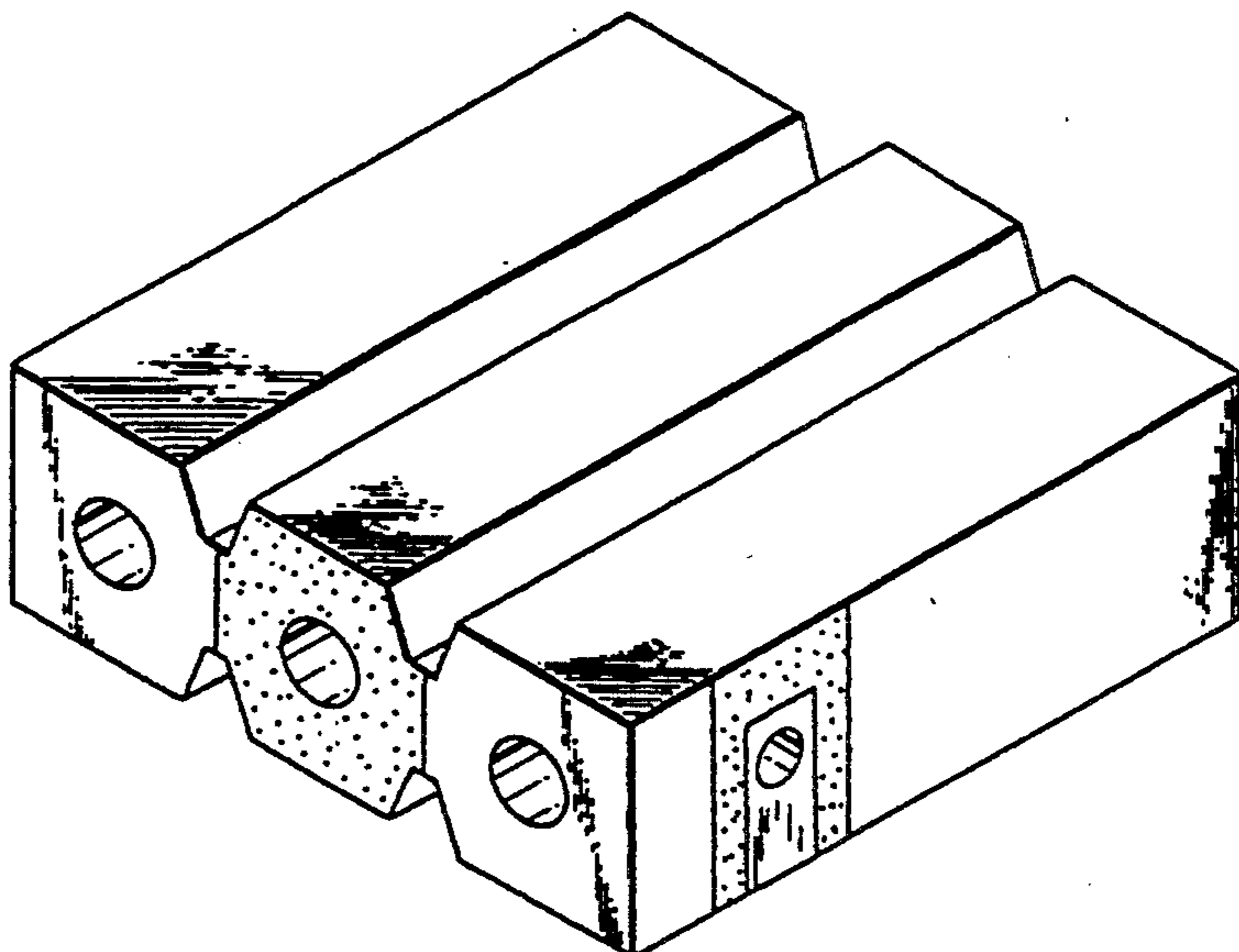

FIG. 16

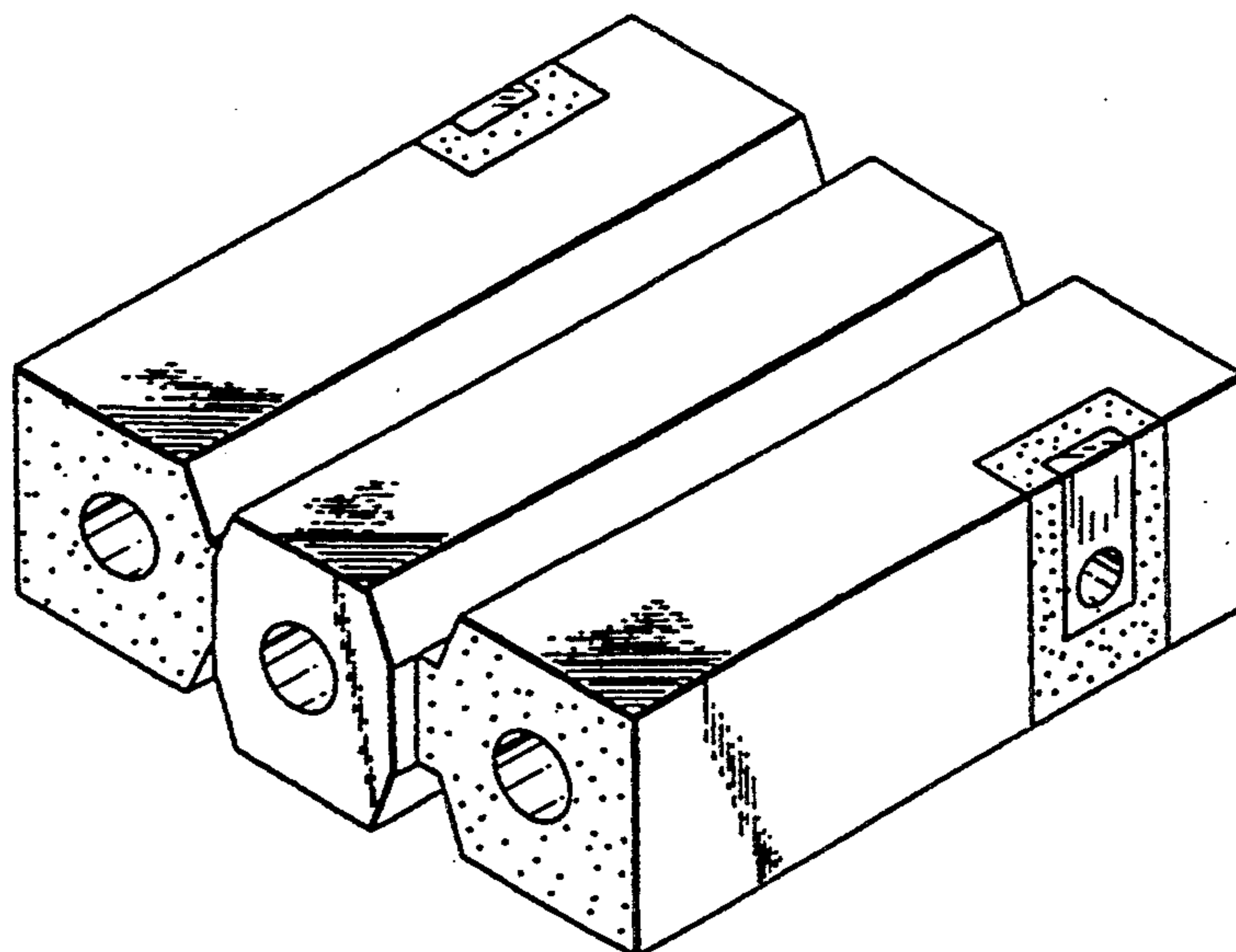

FIG. 17

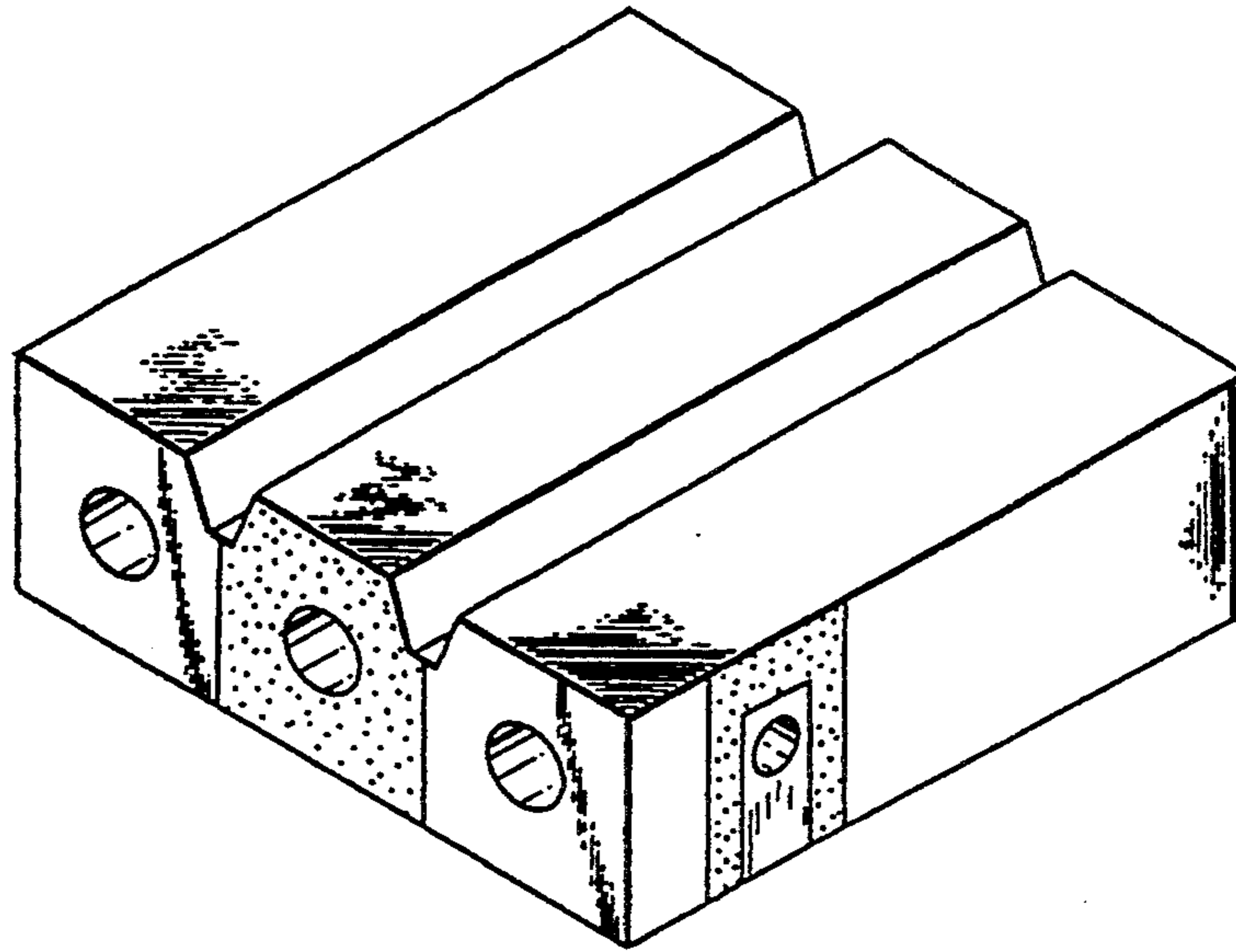

FIG. 18

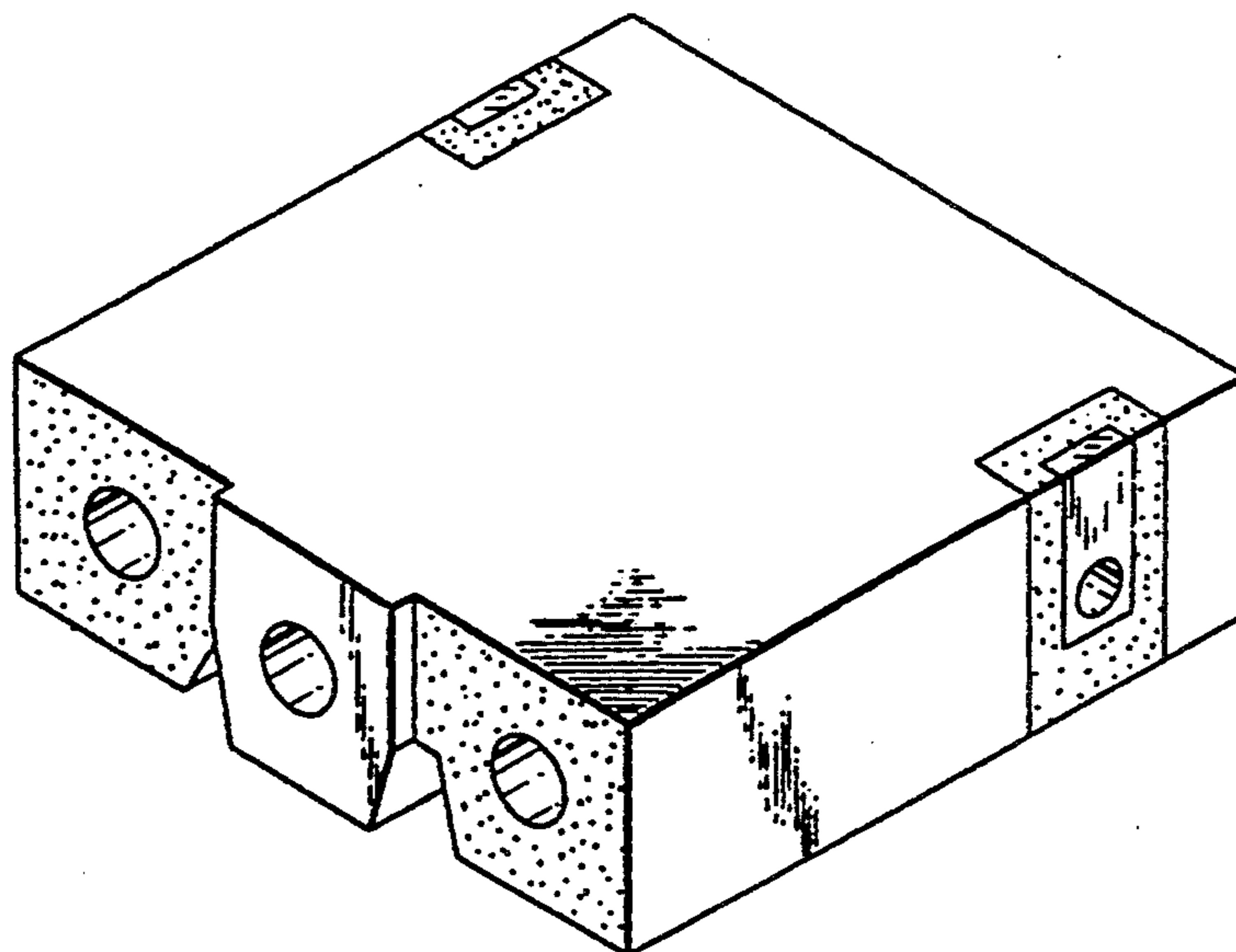

FIG. 19

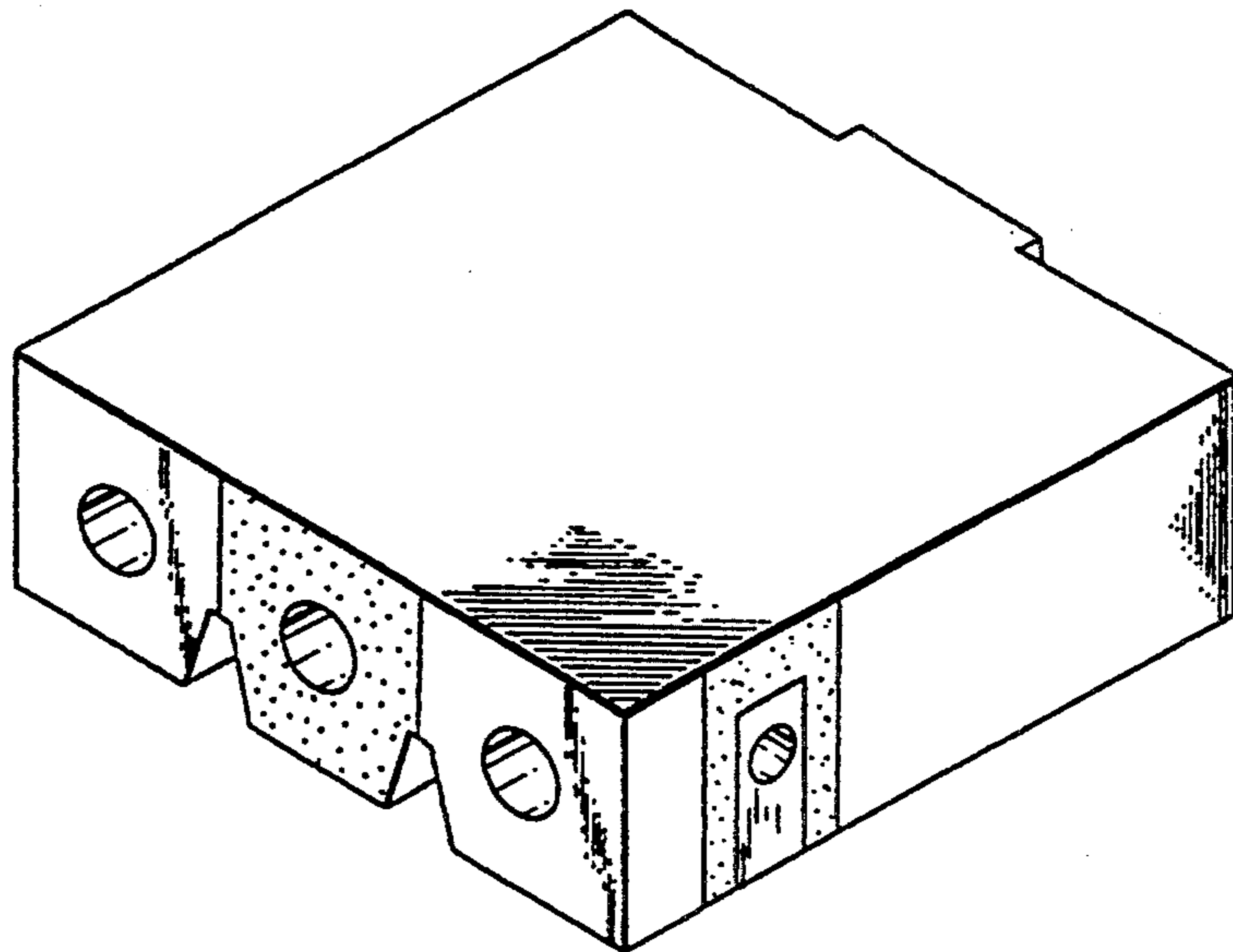

FIG. 20

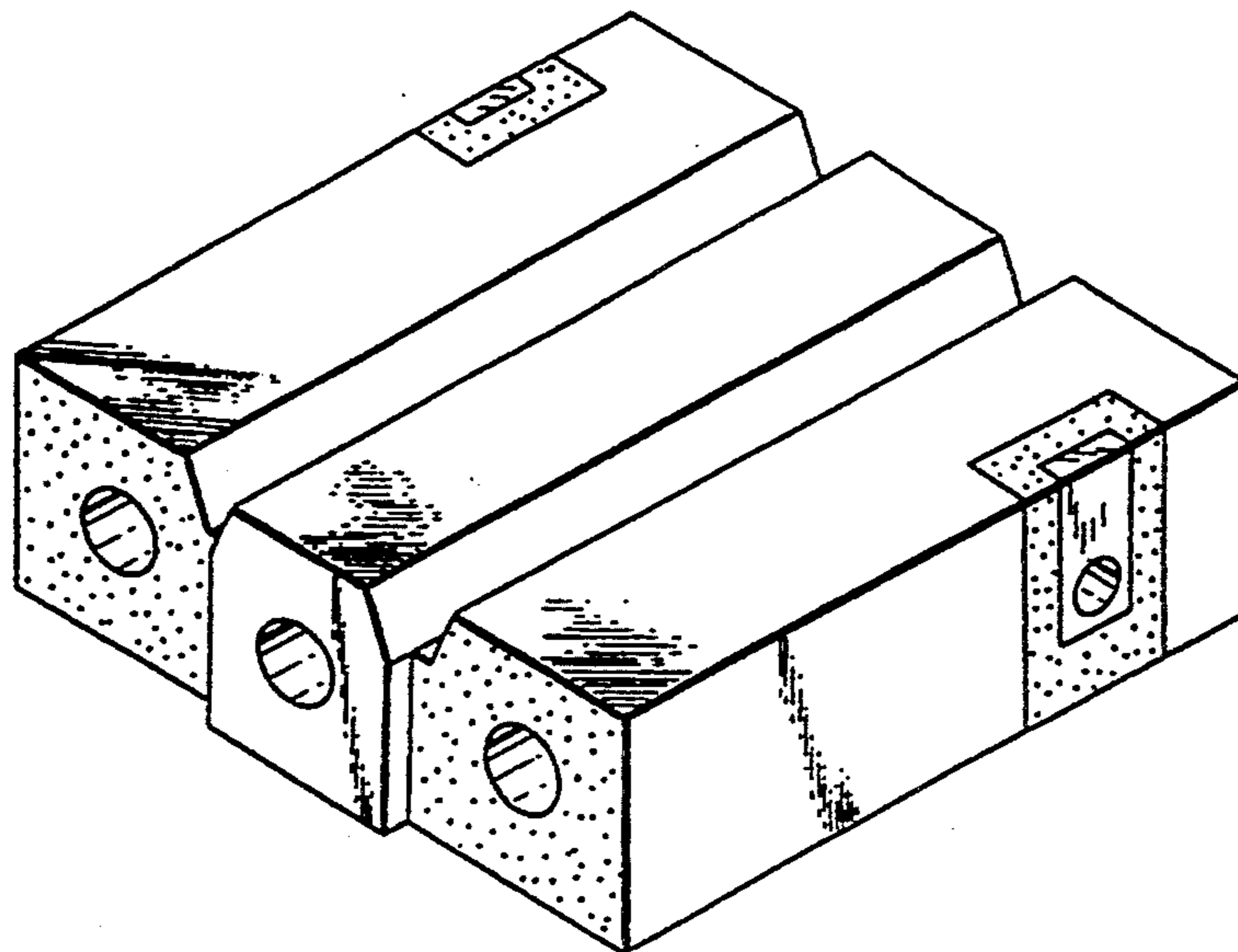

FIG. 21

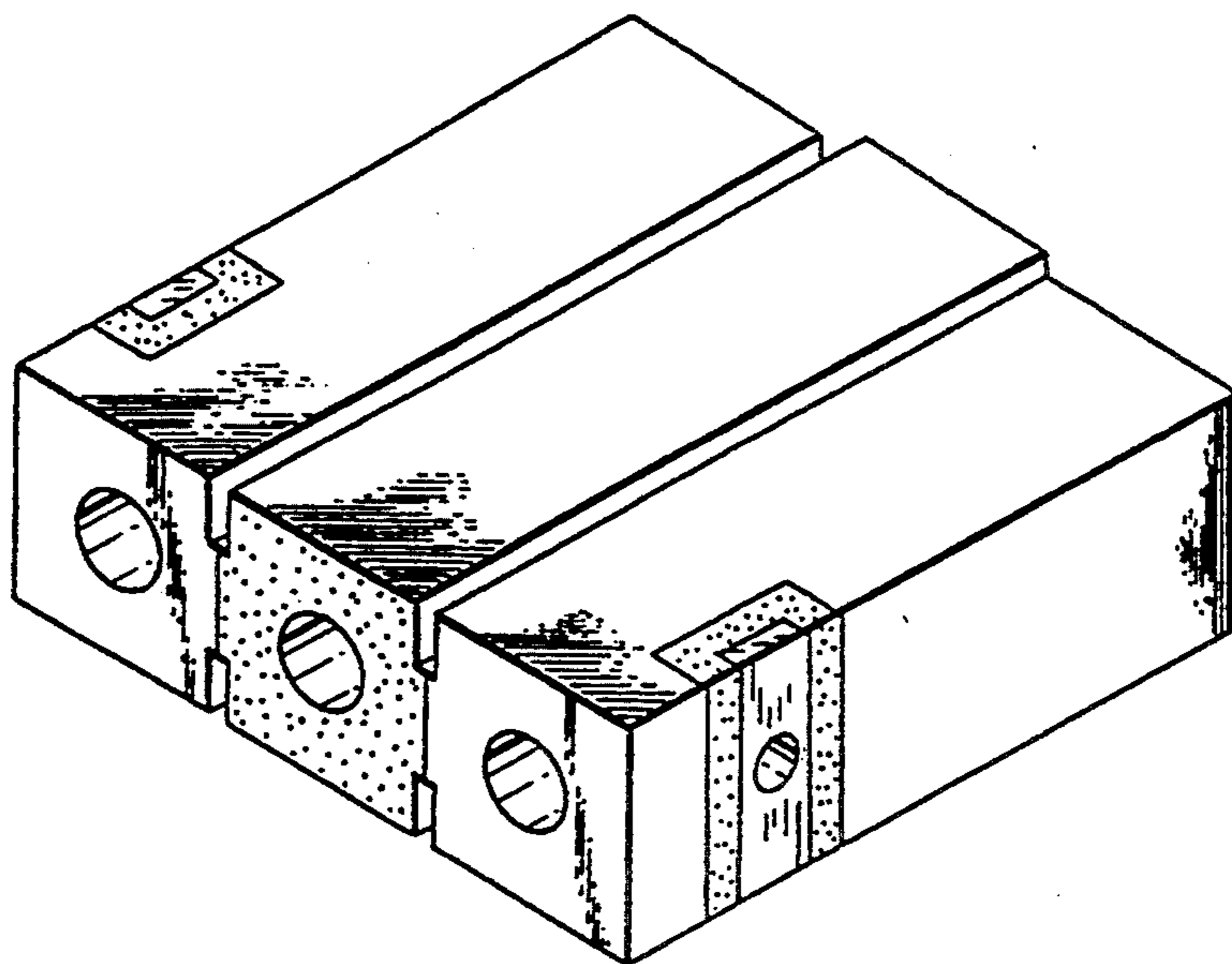

FIG. 22

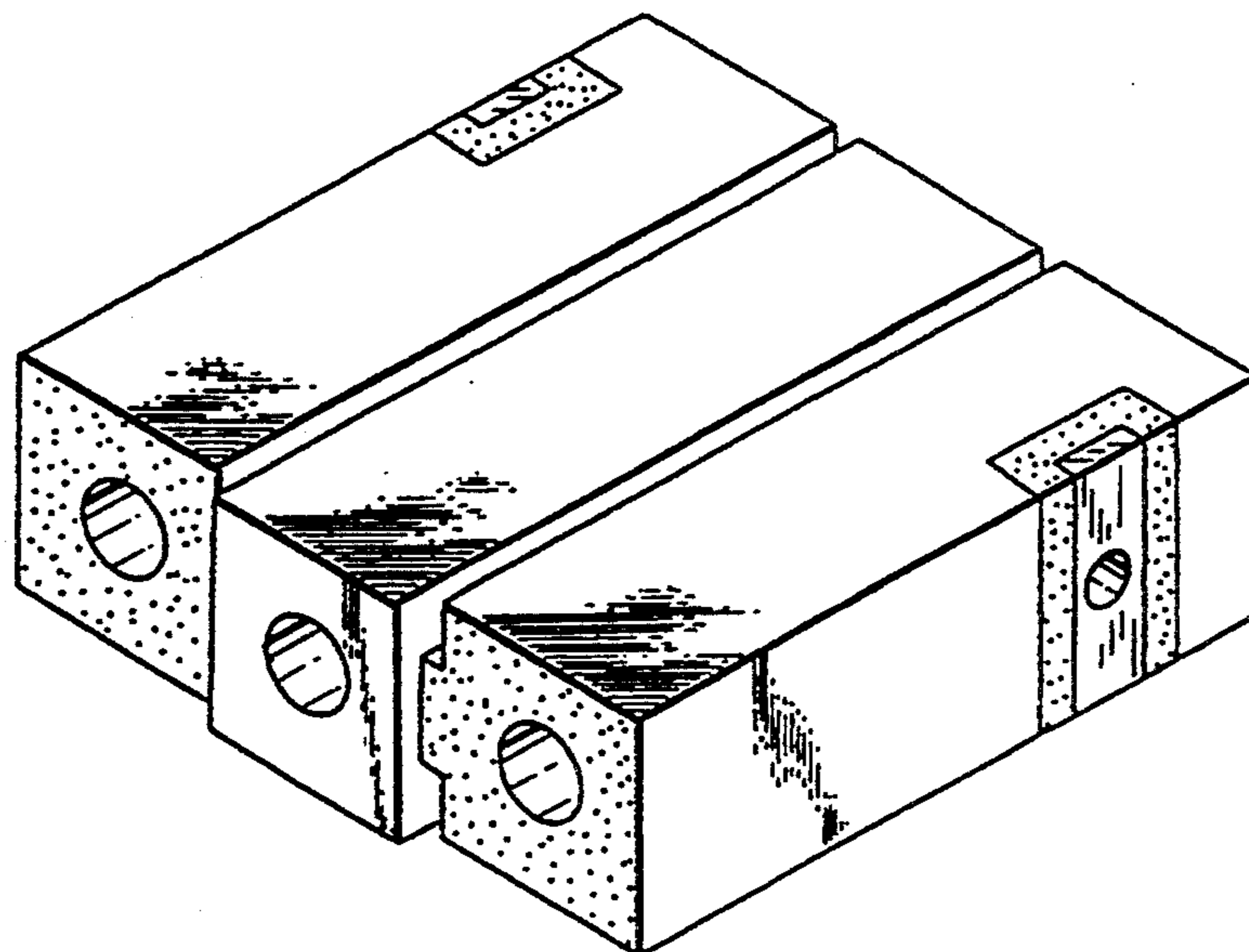

FIG. 23

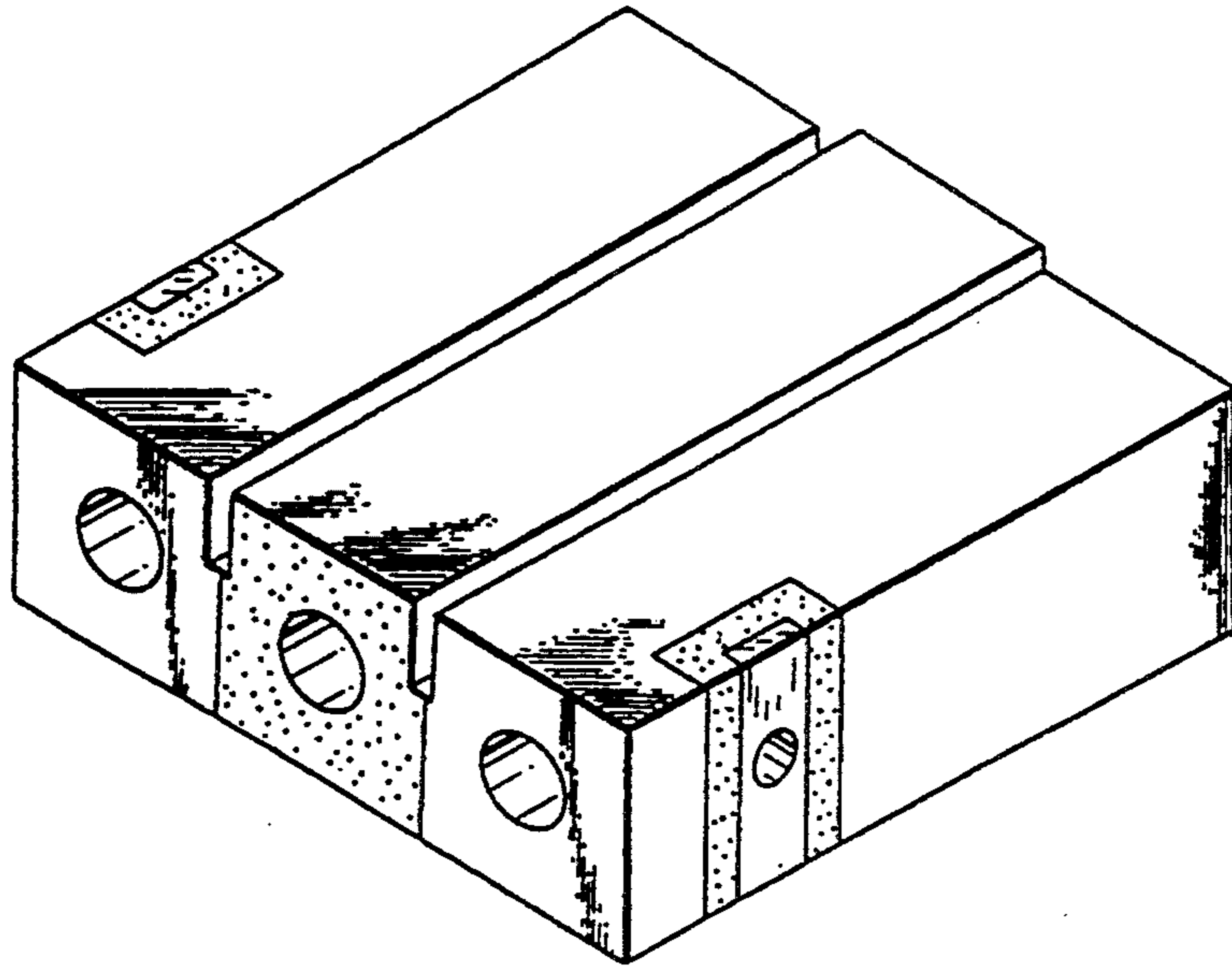

FIG. 24

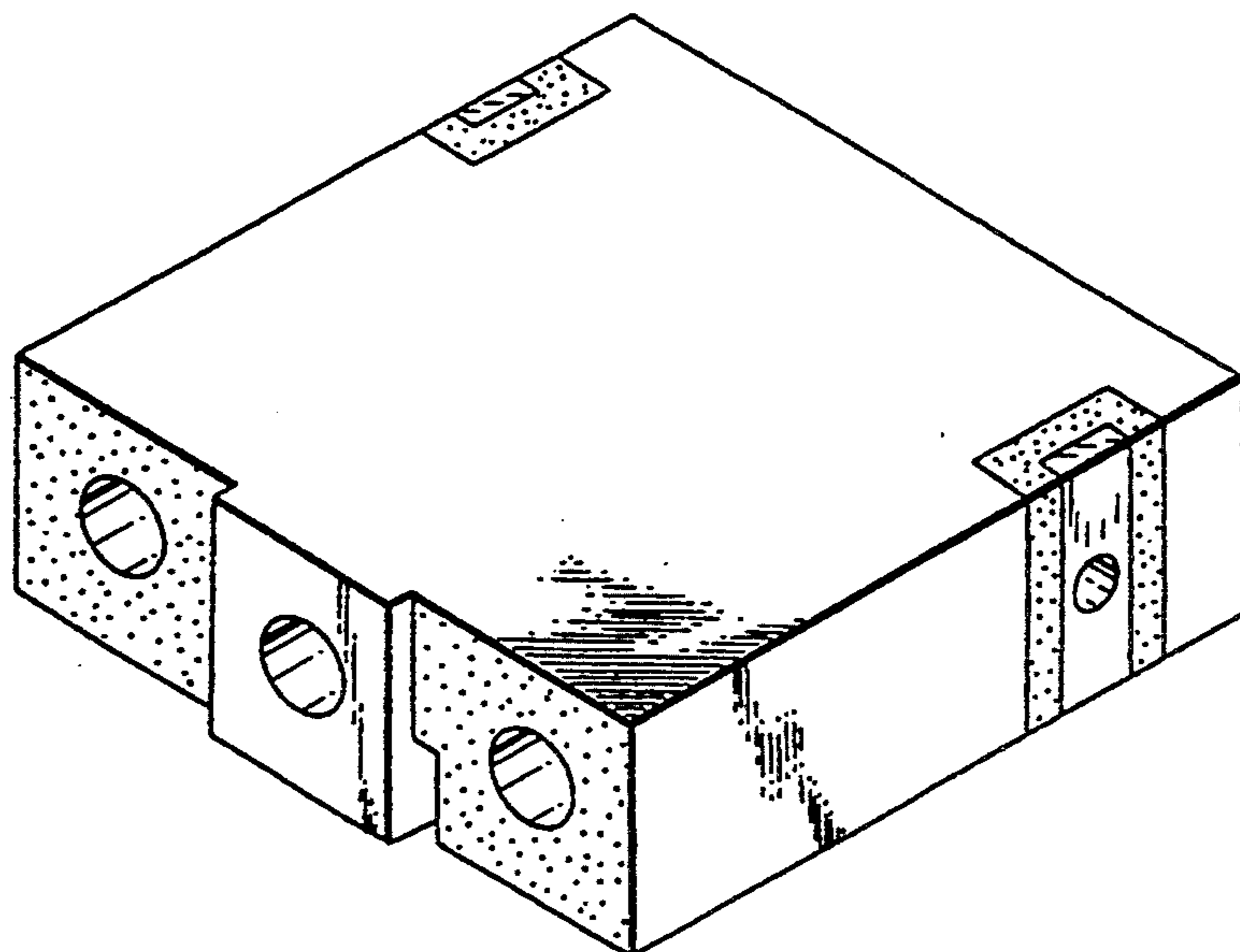

FIG. 25

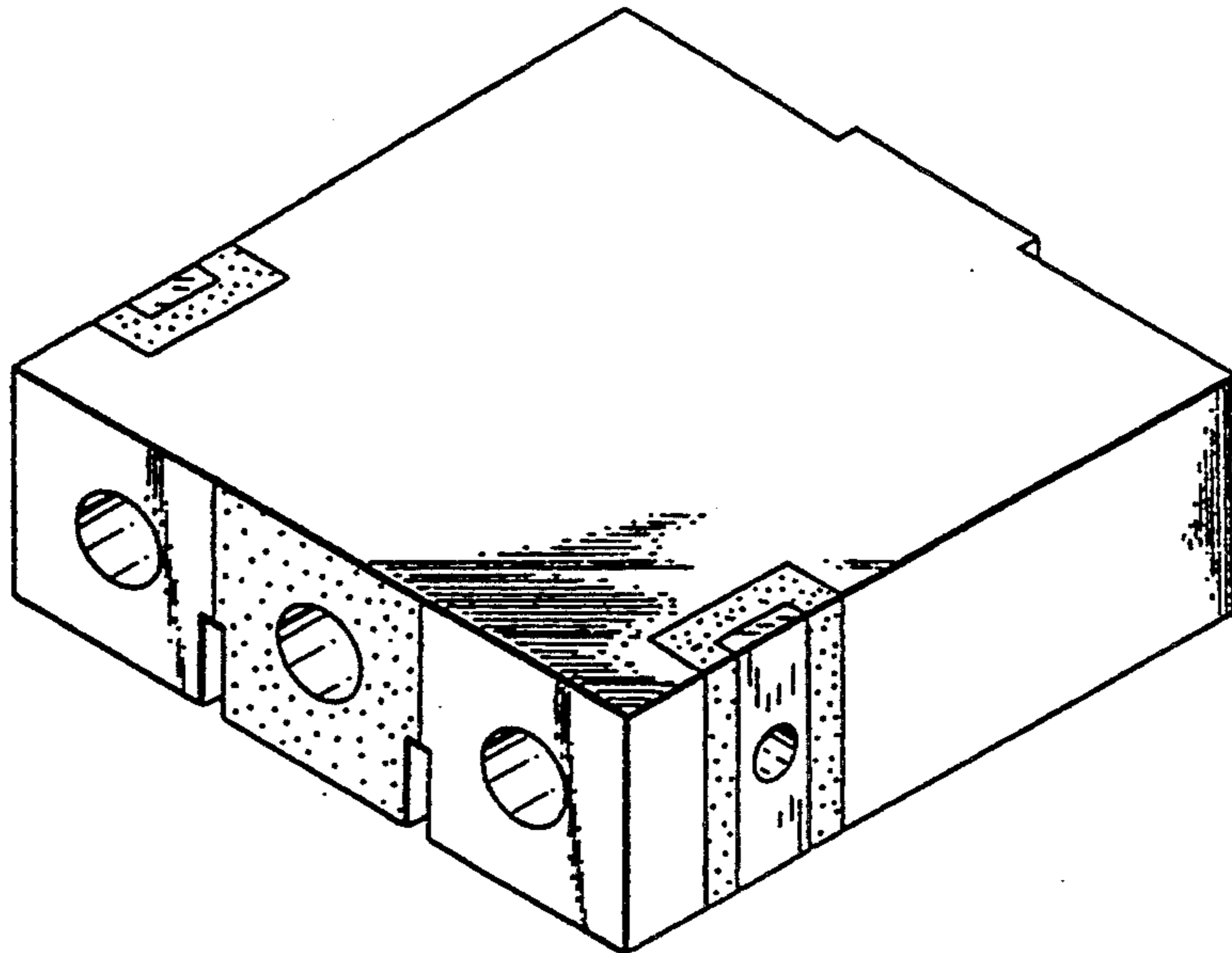

FIG. 26

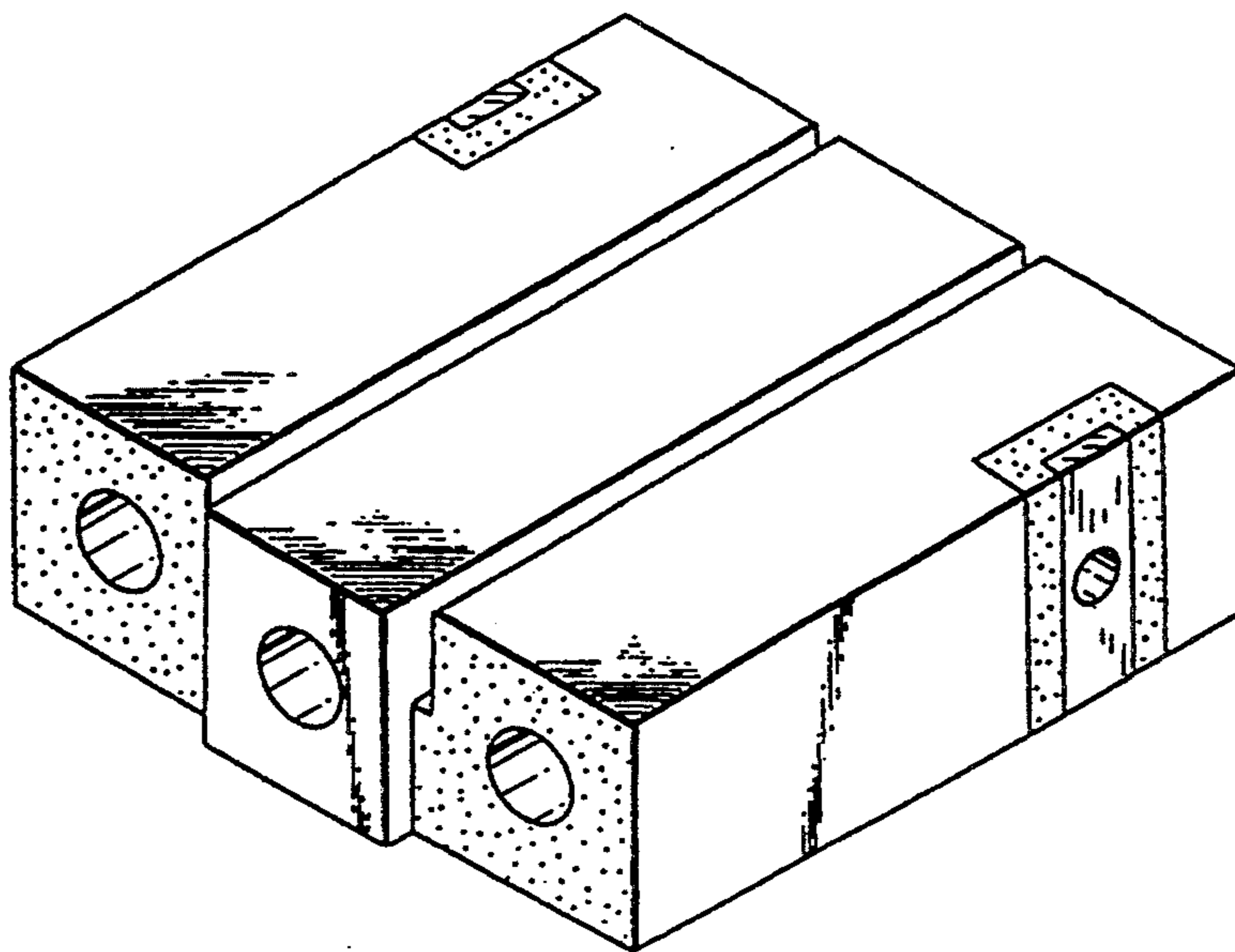

FIG.27

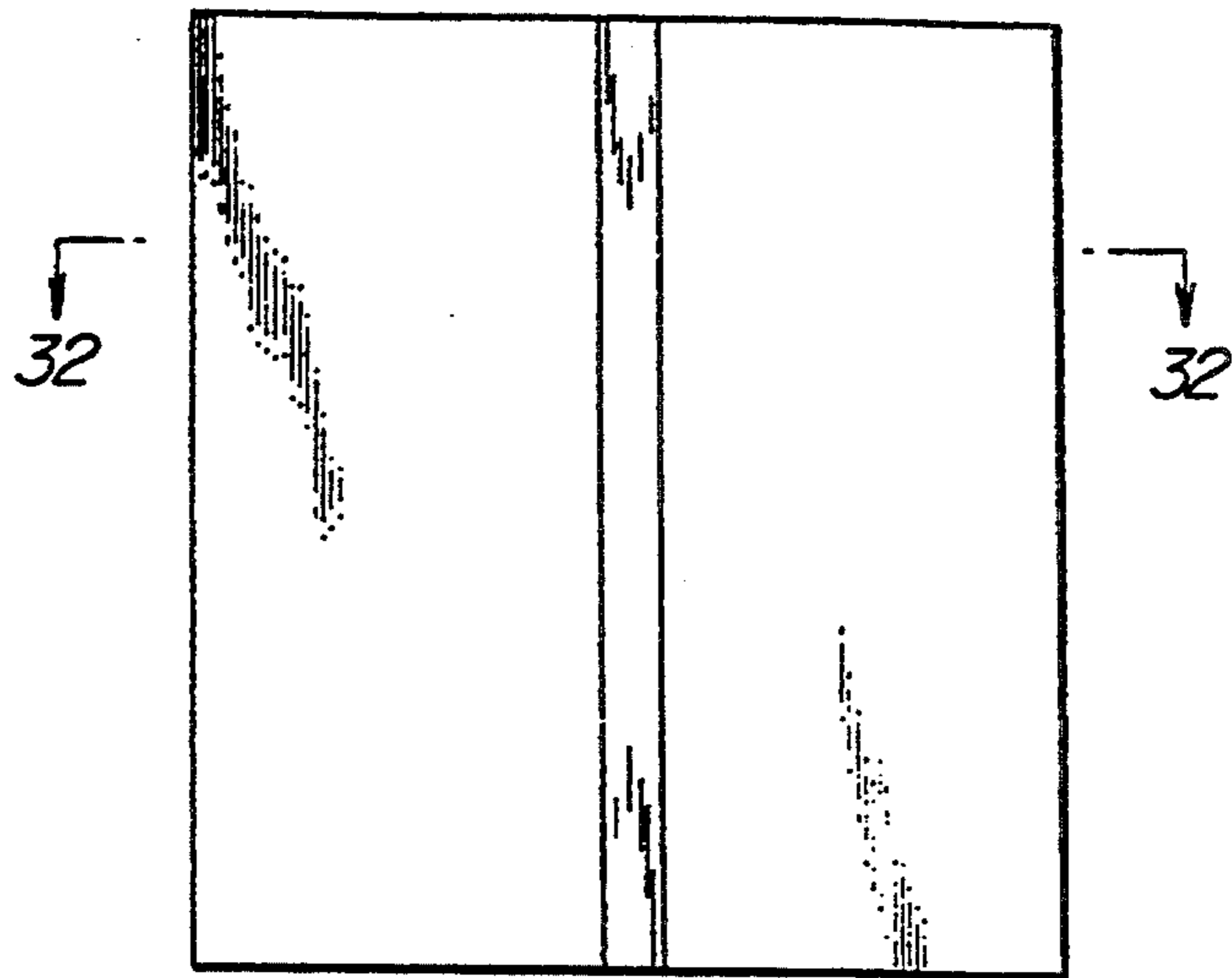

FIG.28

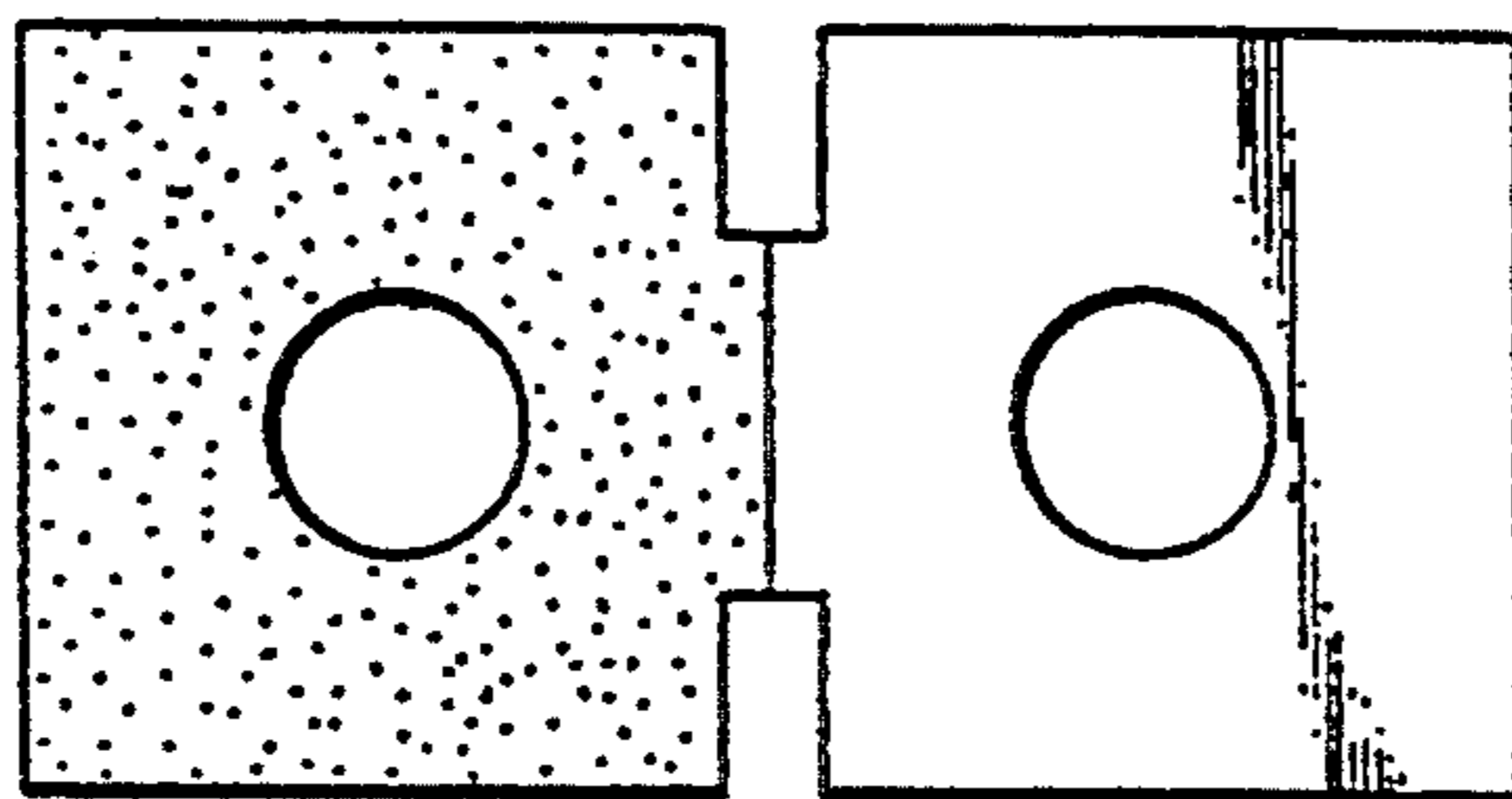

FIG.29

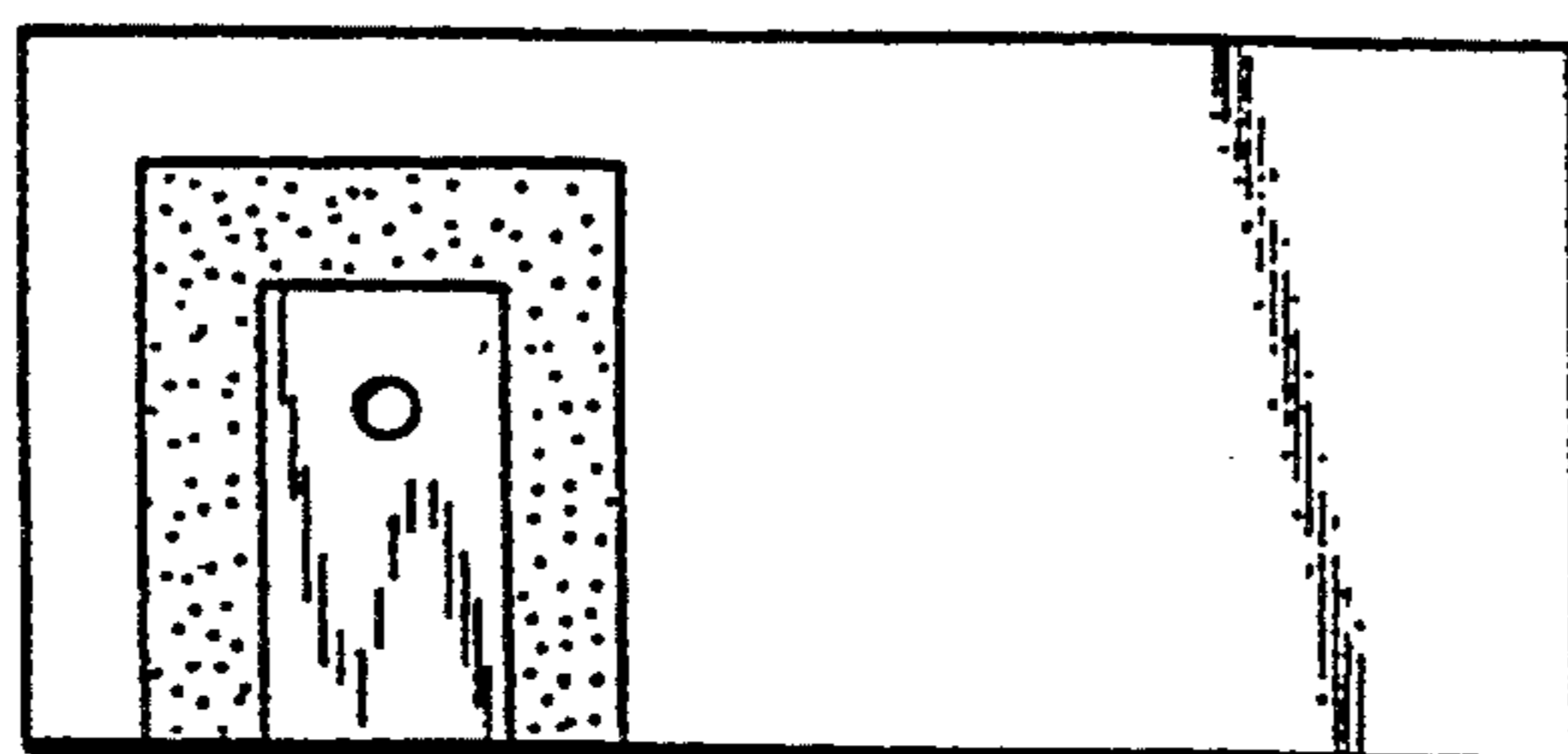

FIG.30

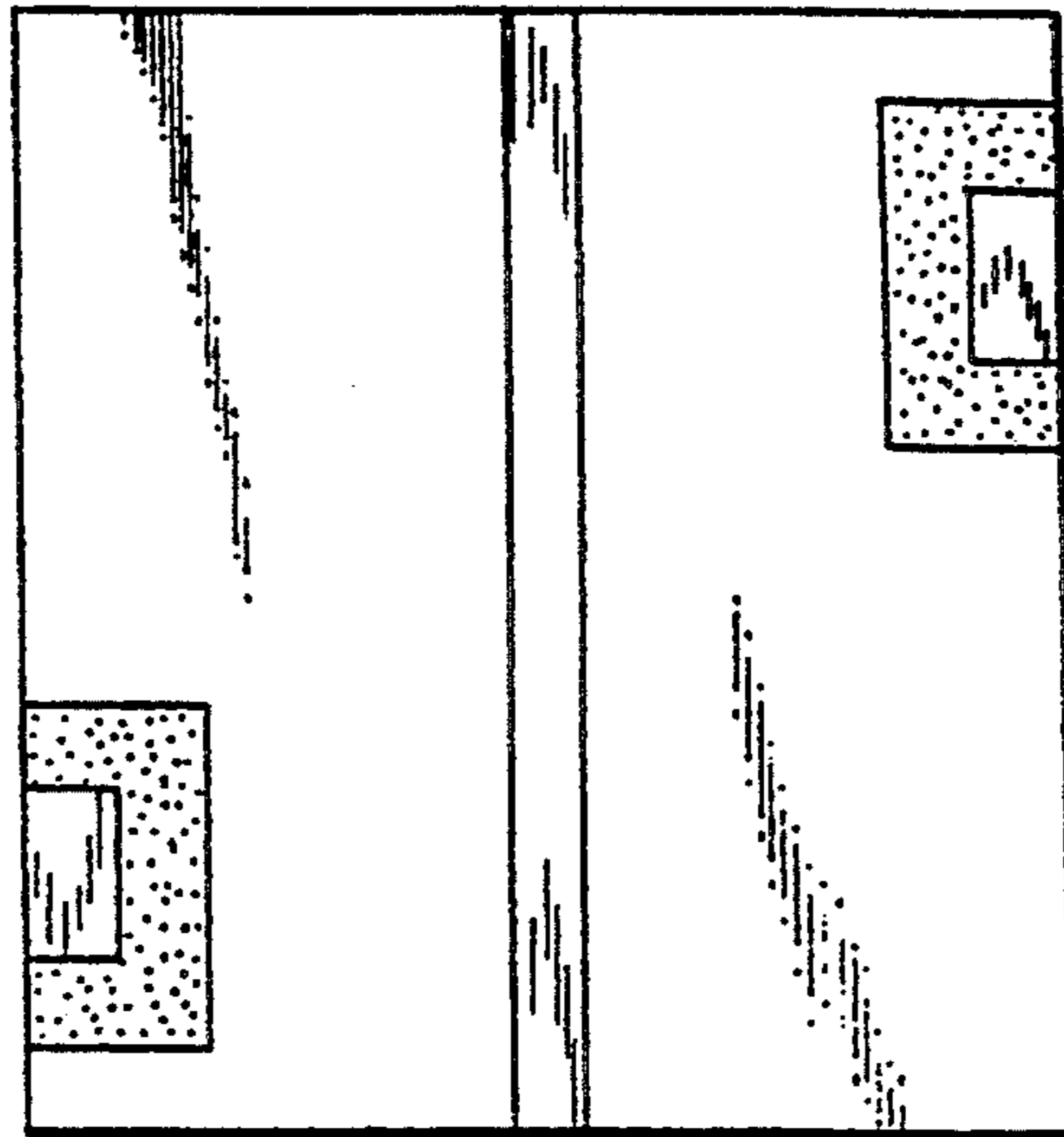

FIG.31

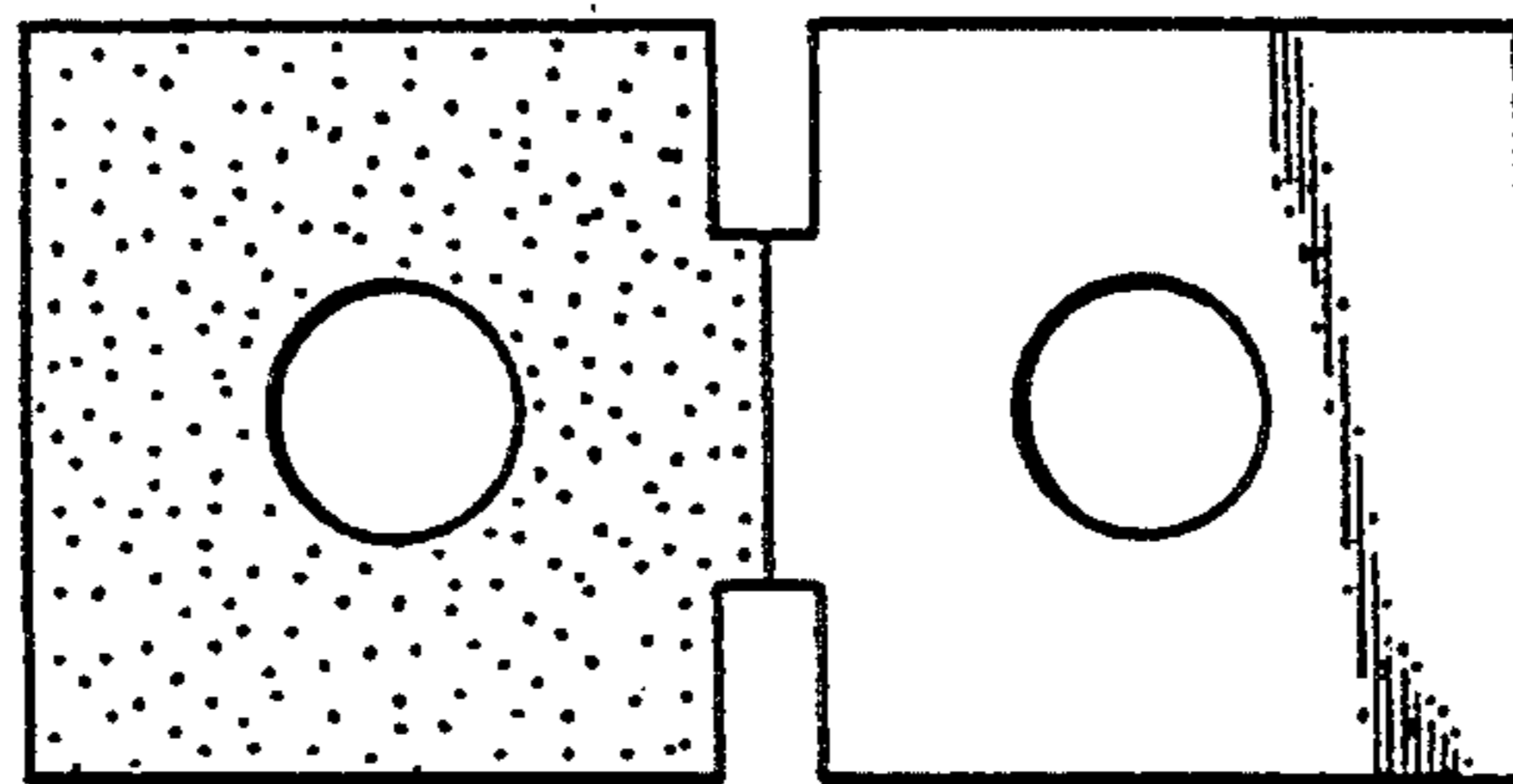

FIG.32

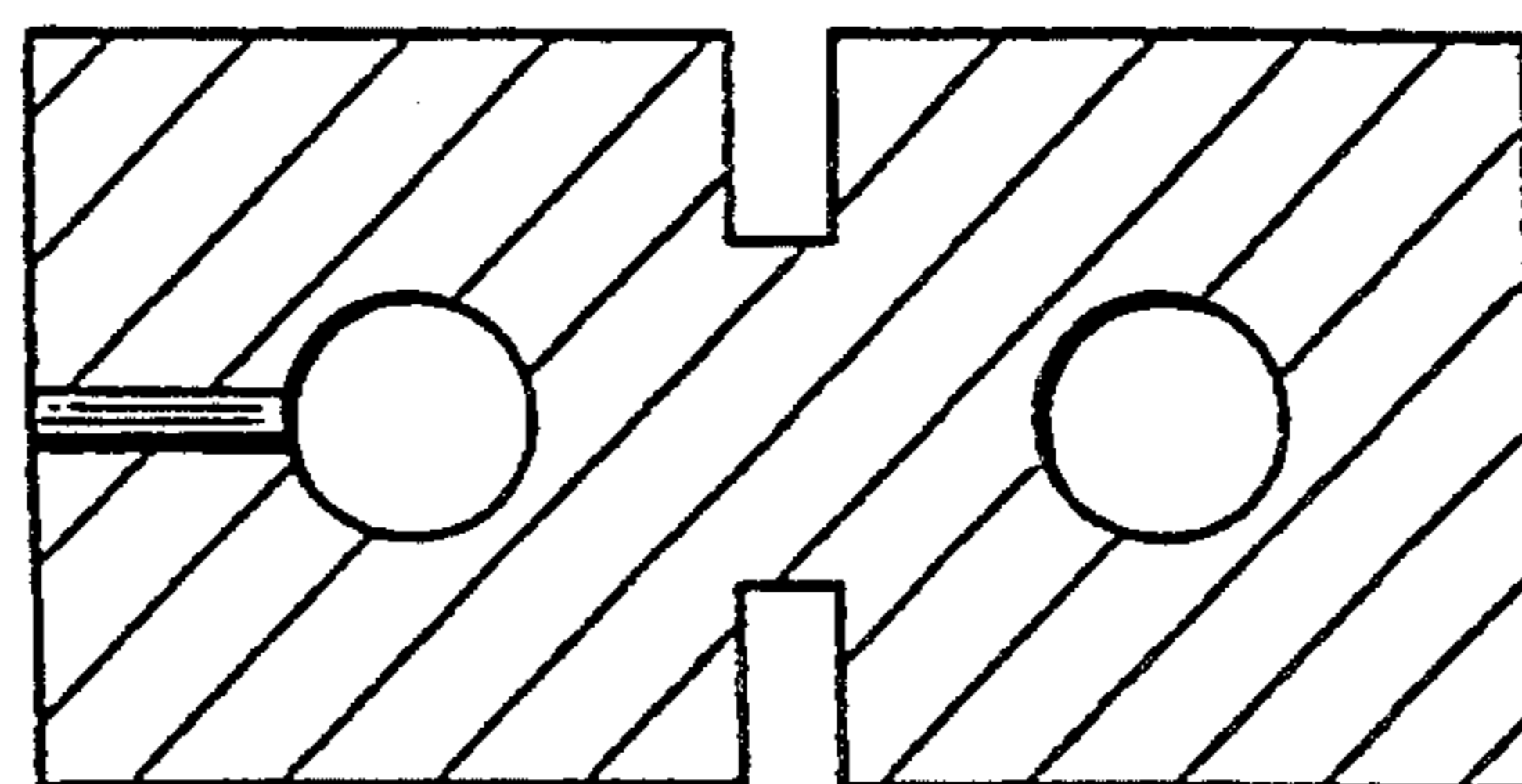

FIG. 33

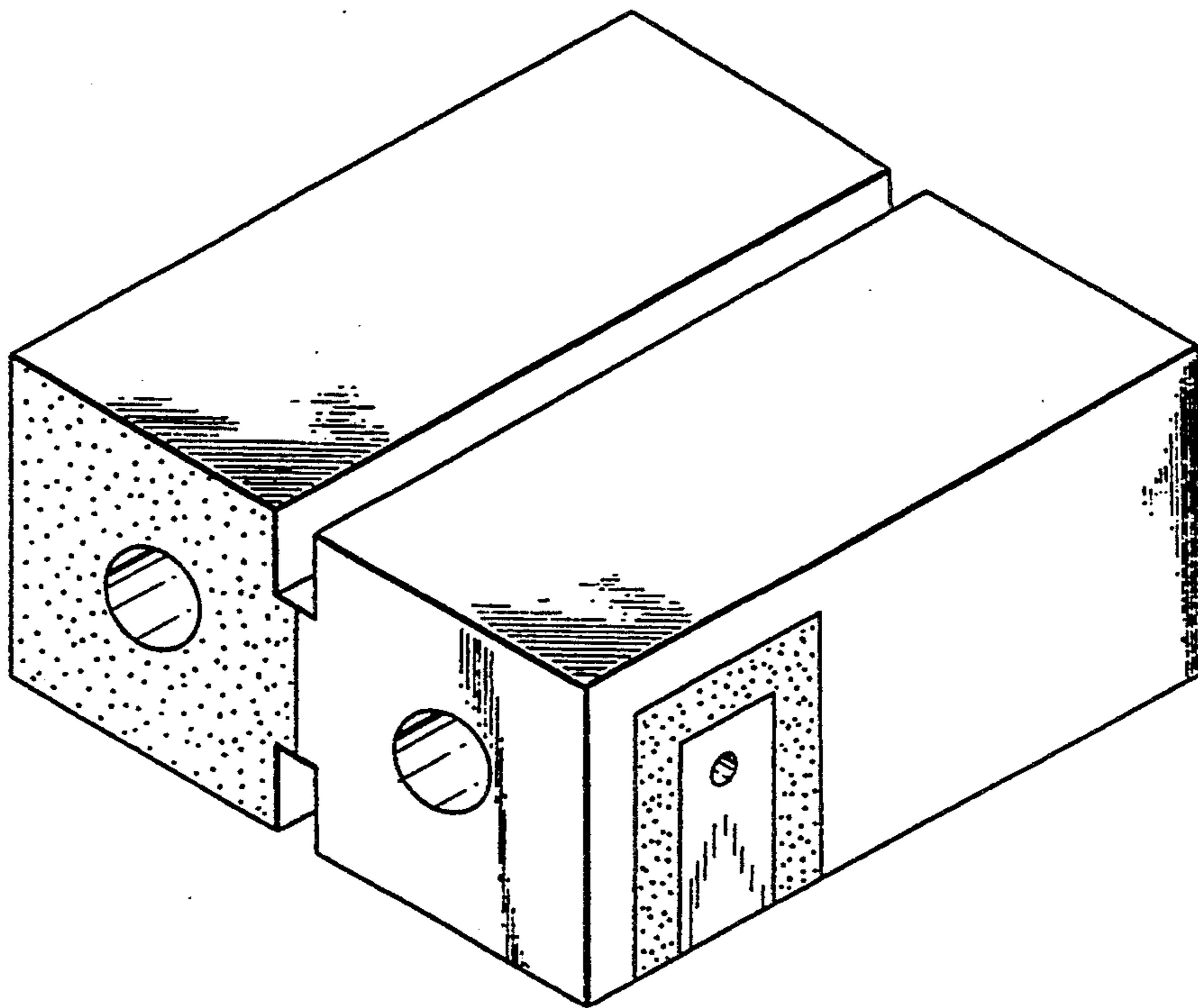

FIG. 34

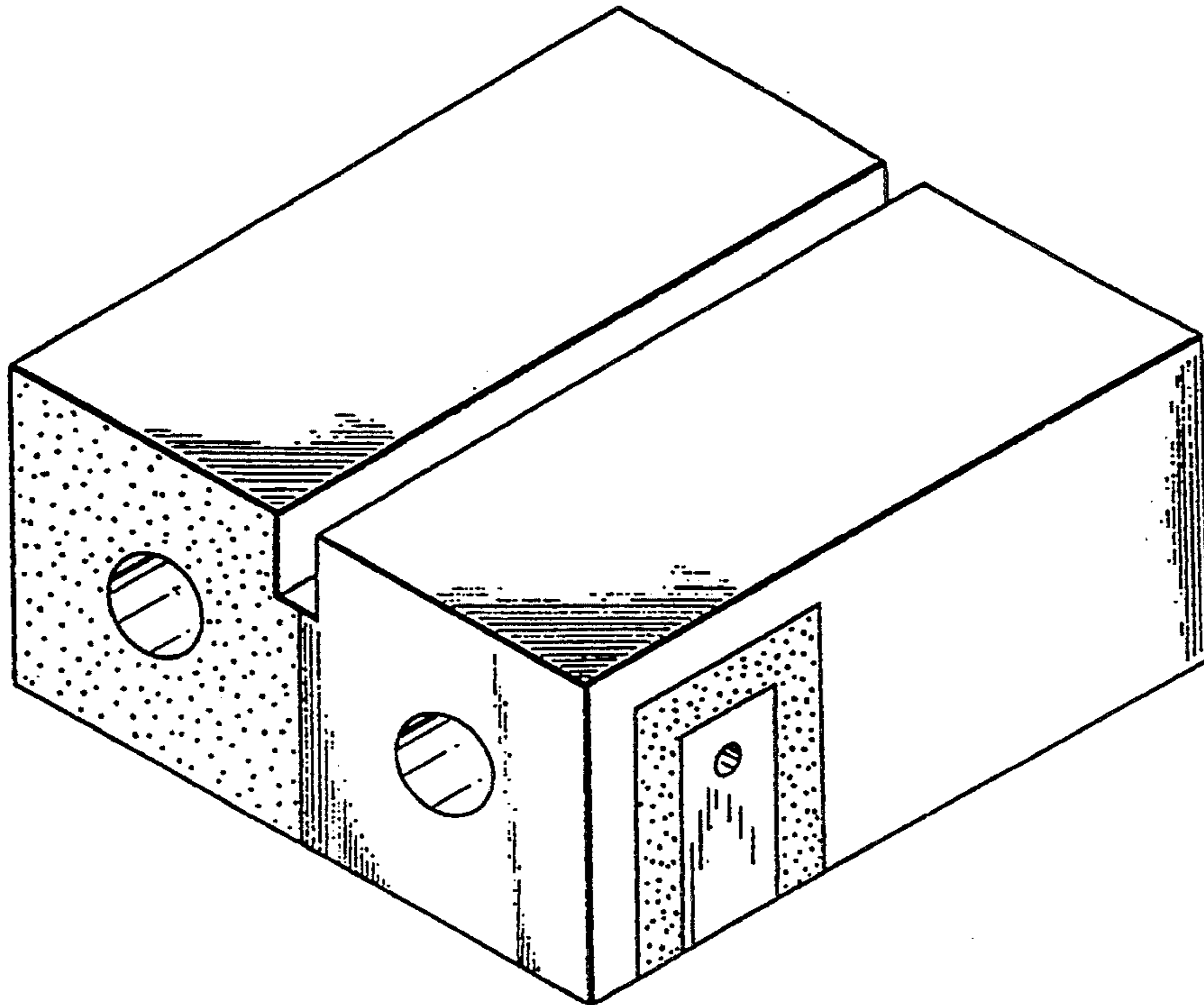

FIG. 35

