



US00D358802S

United States Patent [19]

[11] Patent Number: **Des. 358,802**

Kunz

[45] Date of Patent: **** May 30, 1995**

[54] **SNAGLESS STRAIN RELIEF FOR MODULAR PLUGS**

4,729,741 3/1988 Peng 439/135 X

[75] Inventor: **James B. Kunz**, Blackstone, Mass.

[73] Assignee: **ACS Industries, Inc.**, Woonsocket, R.I.

[**] Term: **14 Years**

[21] Appl. No.: **27,957**

[22] Filed: **Sep. 2, 1994**

[52] U.S. Cl. **D13/154**

[58] Field of Search **D13/133, 137, 138, 143, D13/146, 147, 154; D8/356; 174/135; 439/135, 449, 474, 483, 536**

[56] **References Cited**

U.S. PATENT DOCUMENTS

D. 349,100 7/1994 Lo D13/147
4,536,694 8/1985 McCarthy et al. 439/536 X

OTHER PUBLICATIONS

Connector on German catalog page.

Primary Examiner—James M. Gandy

Assistant Examiner—Joel Sincavage

Attorney, Agent, or Firm—Salter & Michaelson

[57] **CLAIM**

The ornamental design for a snagless strain relief for modular plugs, as shown.

DESCRIPTION

FIG. 1 is a perspective view of a snagless strain relief for modular plugs showing my new design; FIG. 2 is a left side elevational view thereof; FIG. 3 is a right side elevational view thereof; FIG. 4 is a top plan view thereof; FIG. 5 is a bottom plan view thereof; FIG. 6 is a front end view thereof; and, FIG. 7 is a rear end view thereof.

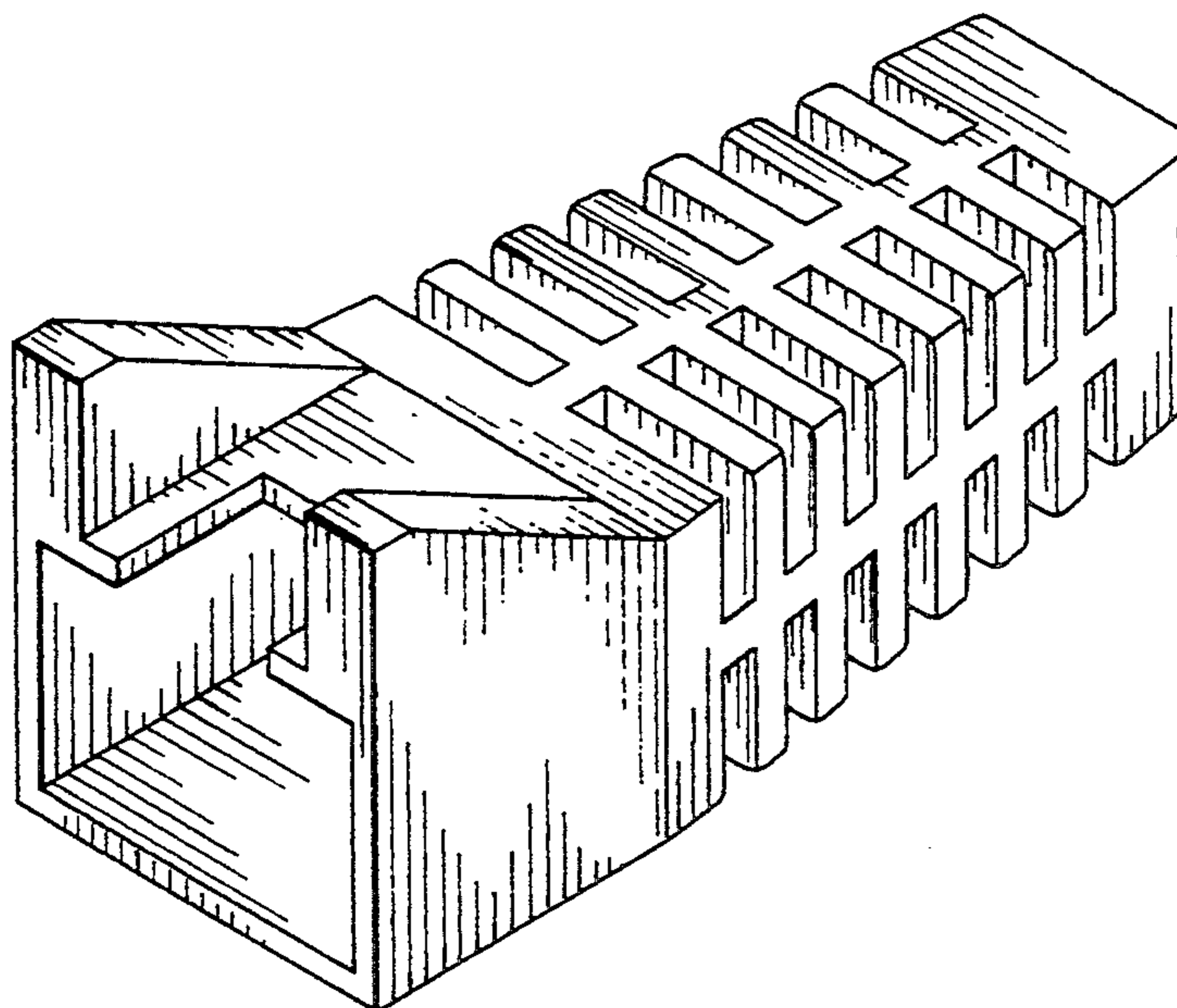

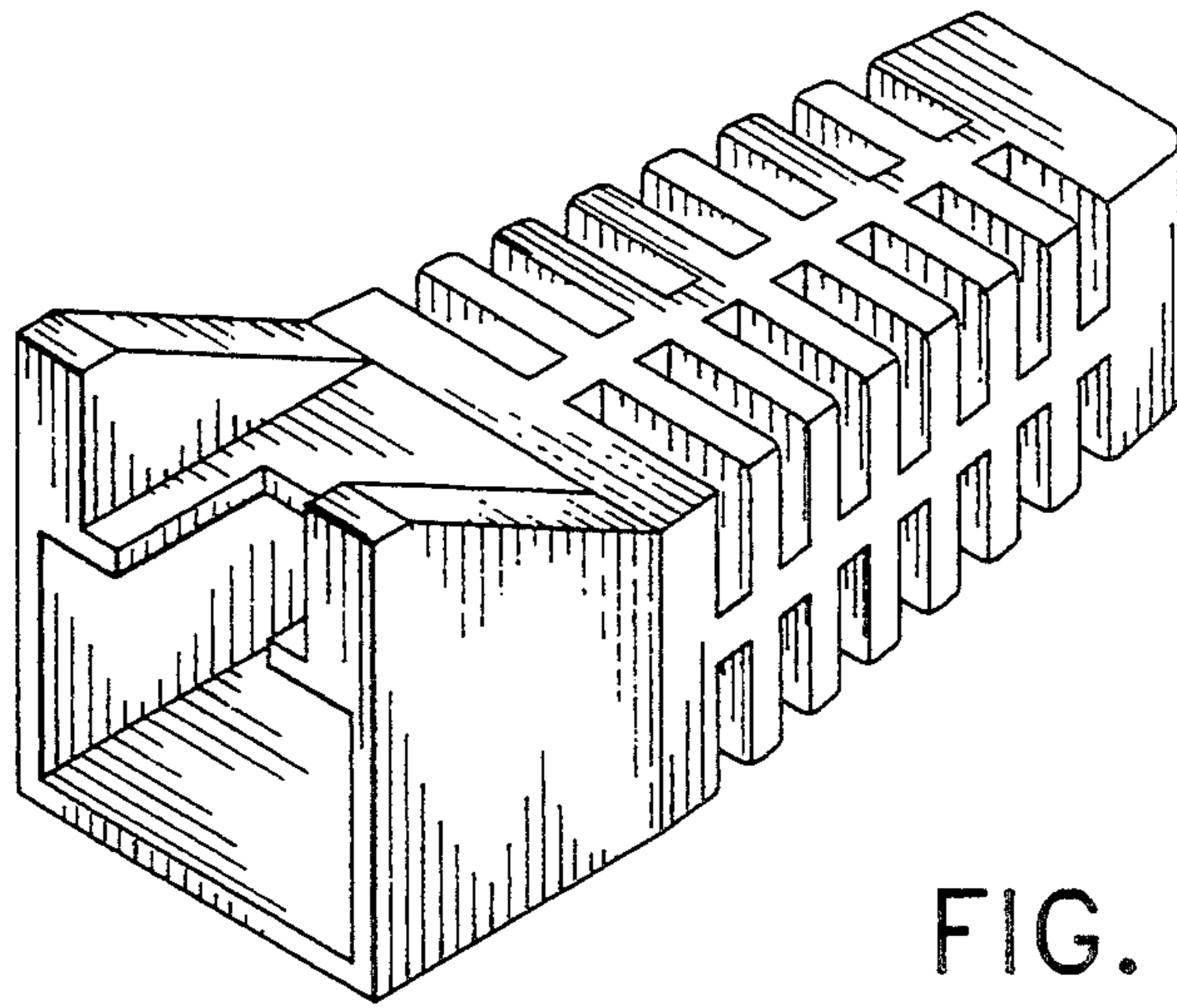

FIG. 1

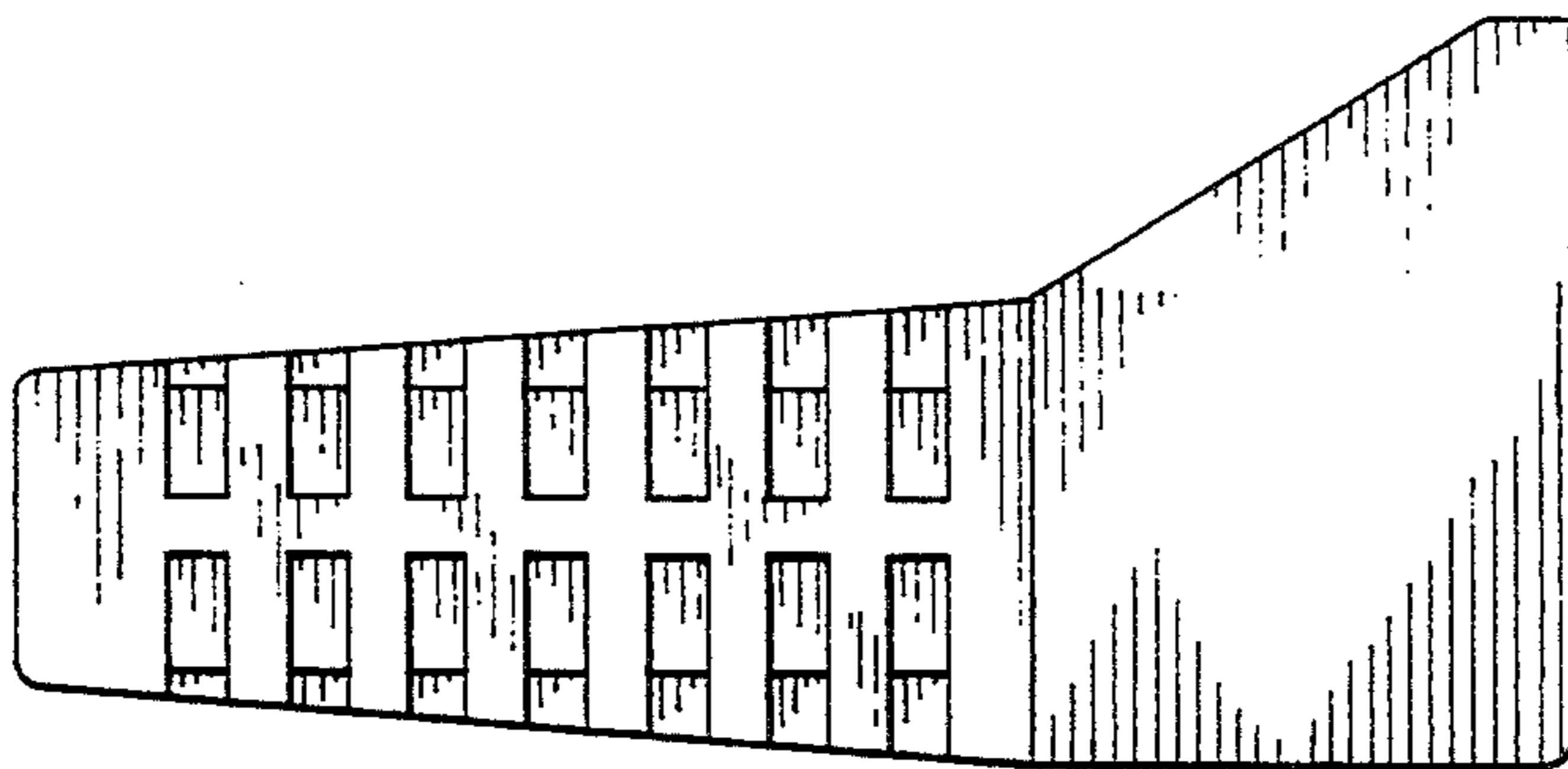

FIG. 2

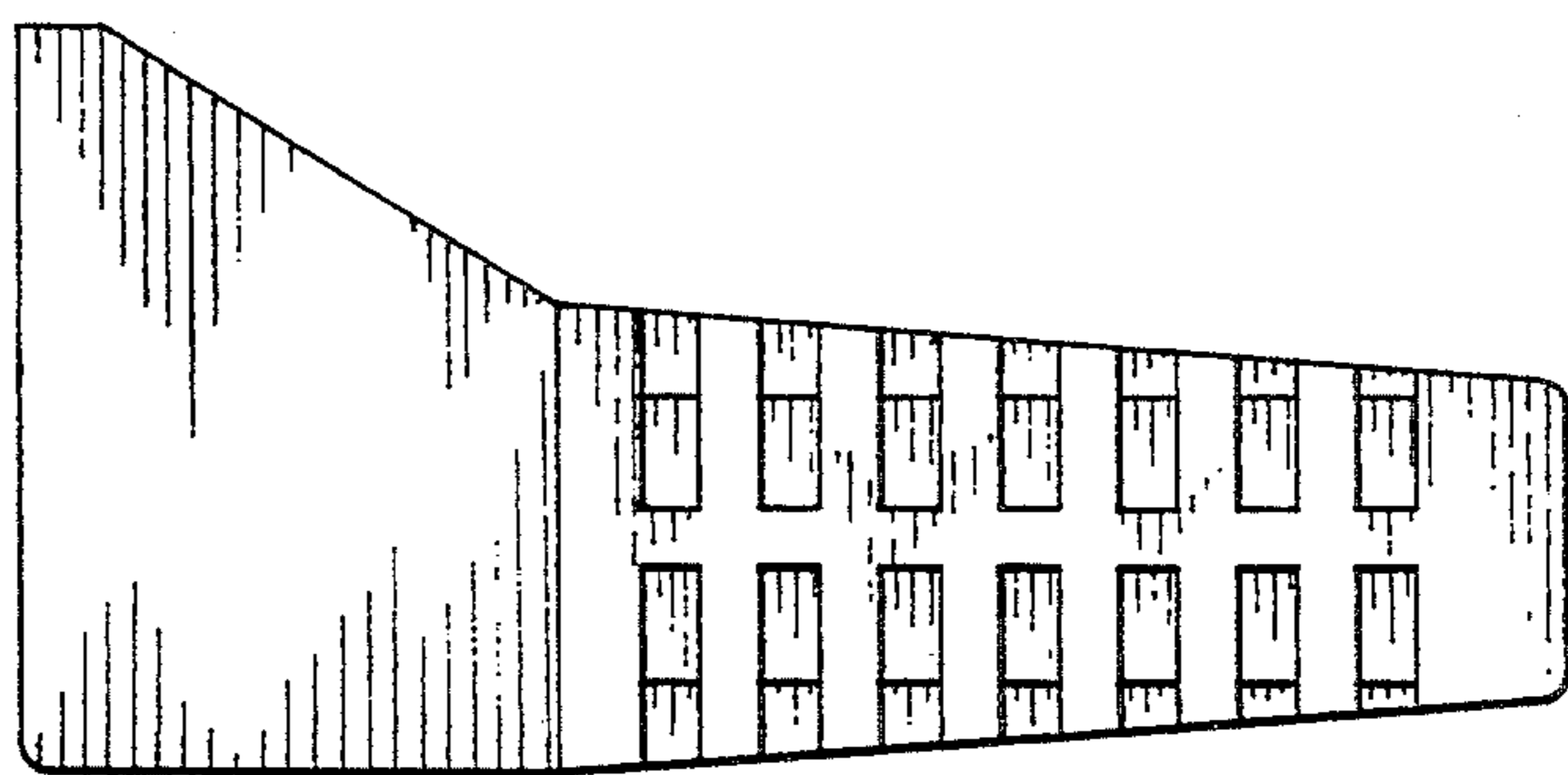

FIG. 3

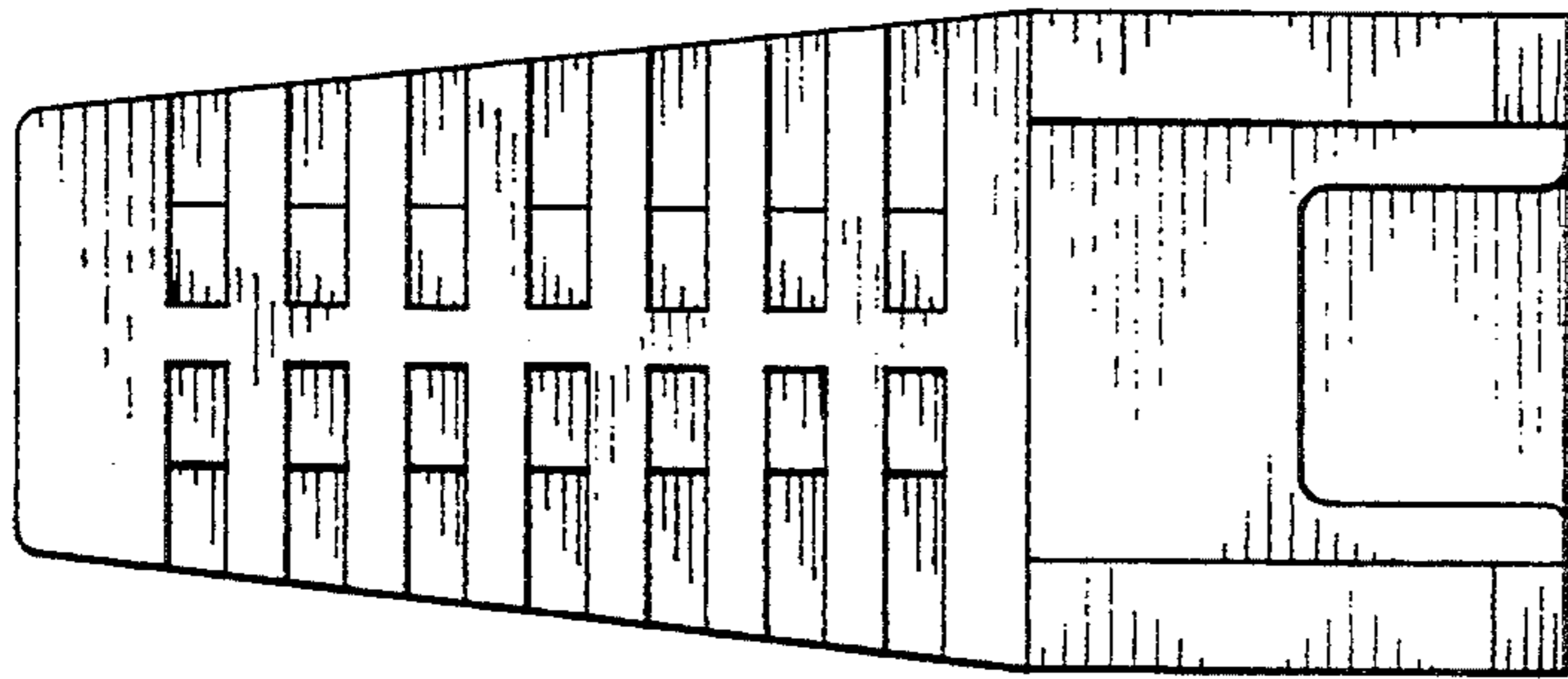

FIG. 4

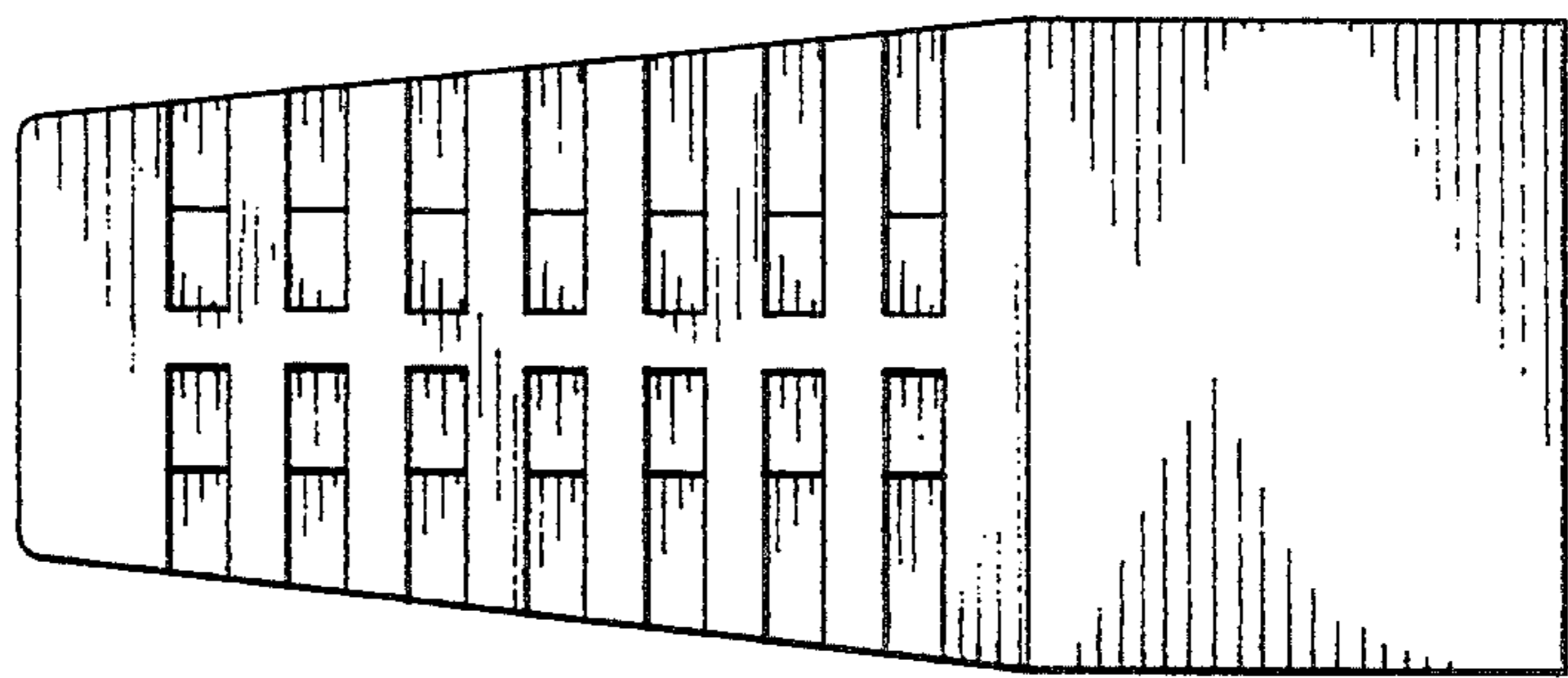

FIG. 5

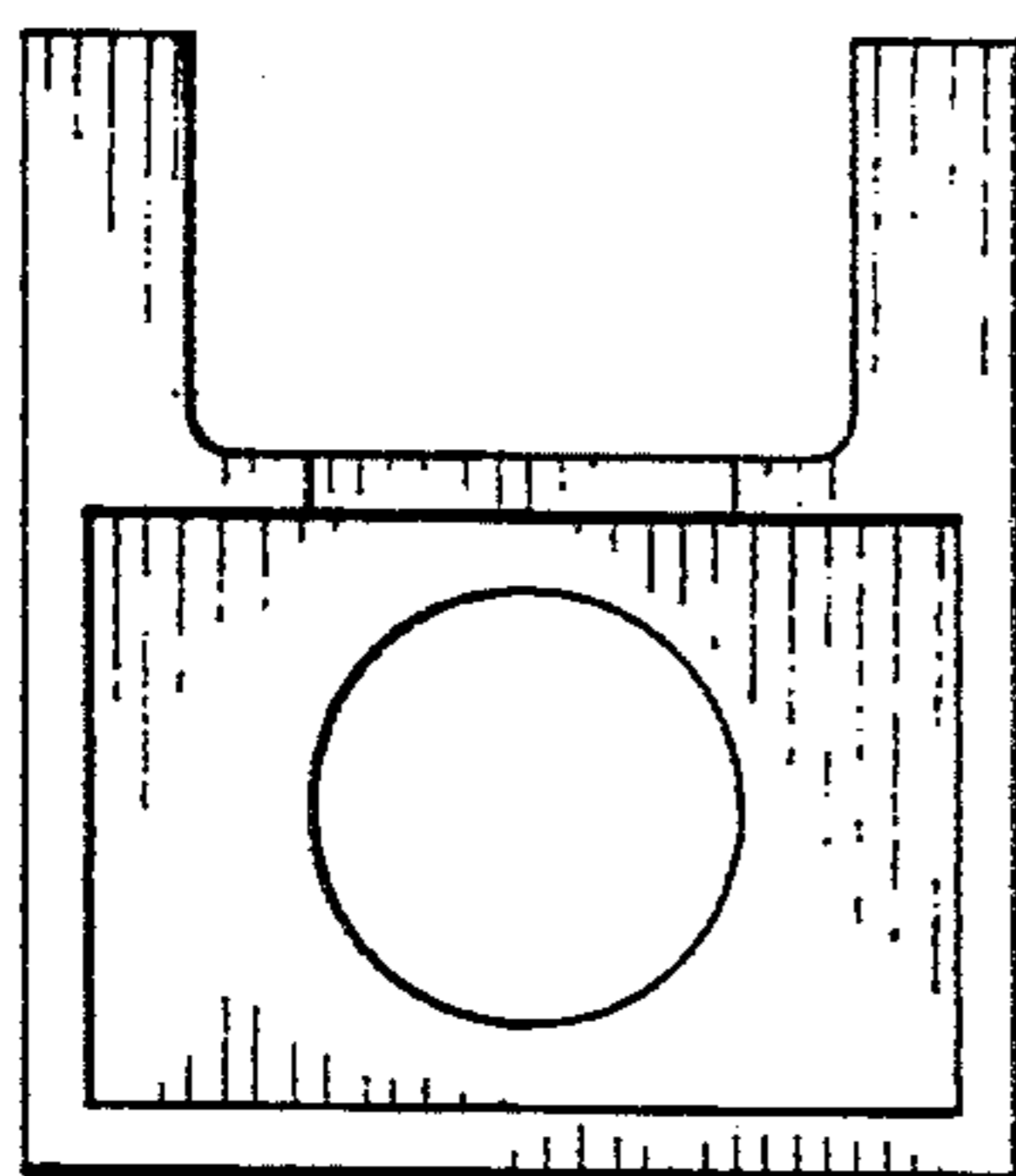

FIG. 6

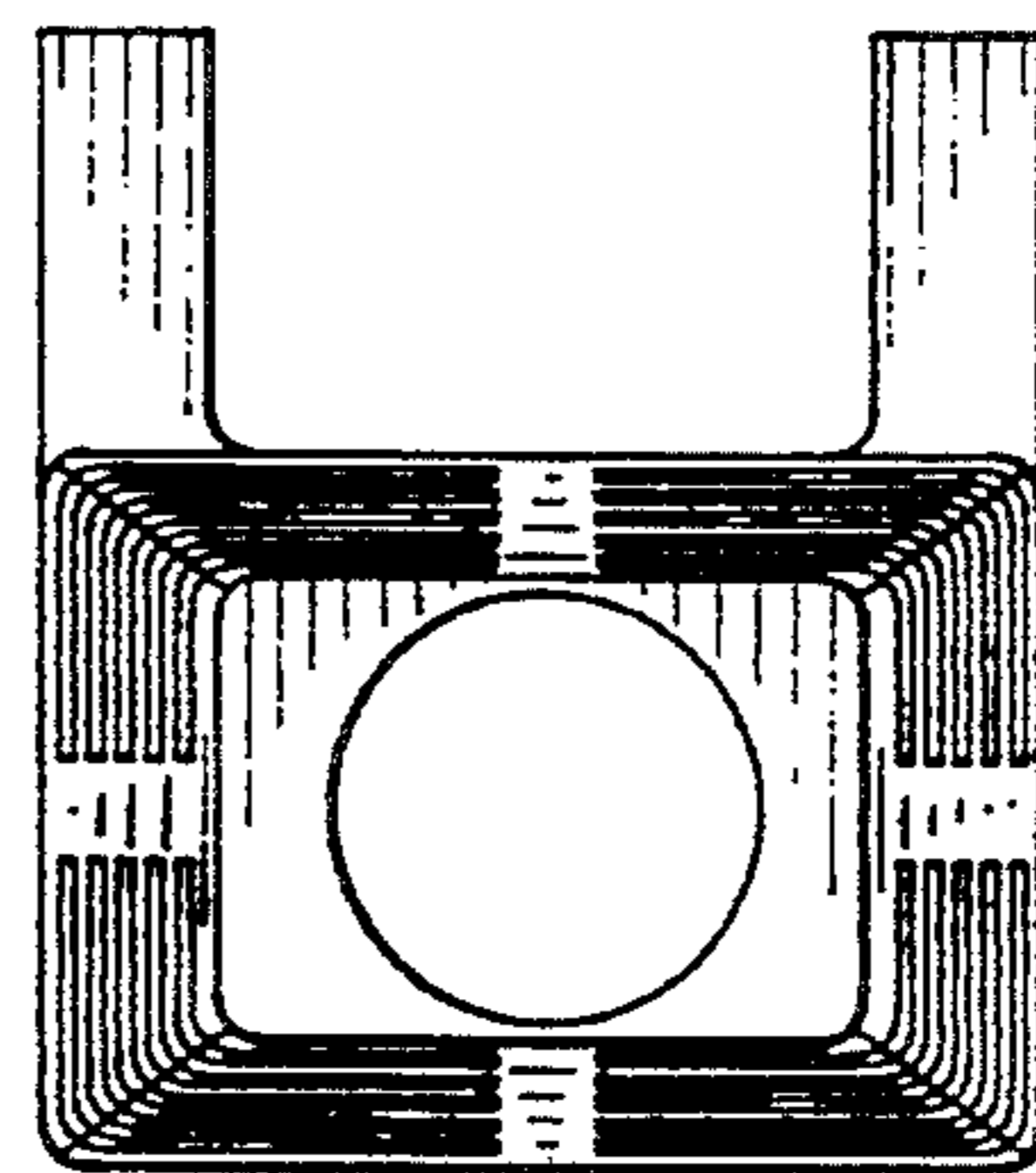

FIG. 7