



US00D358794S

United States Patent [19]

[11] Patent Number: **Des. 358,794**

Thigpen

[45] Date of Patent: **** May 30, 1995**

[54] **TRAILER BALL HITCH COVER KIT**

[76] Inventor: **James R. Thigpen**, 515 N. Fawn Ct., Murfreesboro, Tenn. 37129

[**] Term: **14 Years**

[21] Appl. No.: **5,794**

[22] Filed: **Mar. 10, 1993**

[52] U.S. Cl. **D12/162**

[58] Field of Search **D12/162; D2/244; D7/515; 280/507, 511, 477**

Primary Examiner—James M. Gandy
Assistant Examiner—Melody Brown
Attorney, Agent, or Firm—Richard Litman

[57] **CLAIM**

The ornamental design for a trailer ball hitch cover kit, as shown and described.

DESCRIPTION

FIG. 1 is an environmental perspective view of a trailer ball hitch cover kit showing my new design;

FIG. 2 is a front elevational view of the hat element with the head element removed, the rear, the right side, and the left side being a mirror image thereof;

FIG. 3 is a top view thereof;

FIG. 4 is a bottom view thereof;

FIG. 5 is a front elevational view of the hat element;

FIG. 6 is a rear elevational view thereof;

FIG. 7 is a top view thereof;

FIG. 8 is a left side elevational view with the right side being a mirror image thereof; and,

FIG. 9 is a bottom view thereof.

The broken line showing of the vehicle bumper is for illustrative purposes only and forms no part of the claimed design.

[56] **References Cited**

U.S. PATENT DOCUMENTS

D. 311,992	11/1990	Cox, Jr.	D2/244
D. 317,890	7/1991	Bachmann	D12/162
D. 327,816	7/1992	Paullen	D7/515
D. 336,880	6/1993	Drummond	D12/162
3,228,445	1/1966	Mayotte	280/507
3,596,926	8/1971	Randall	280/507
4,738,293	4/1988	Ostrom et al.	280/507
4,861,062	8/1989	Stidsen	280/507
4,955,968	9/1990	Beckerer, Jr.	280/507
5,037,122	8/1991	Beckerer, Jr.	280/507

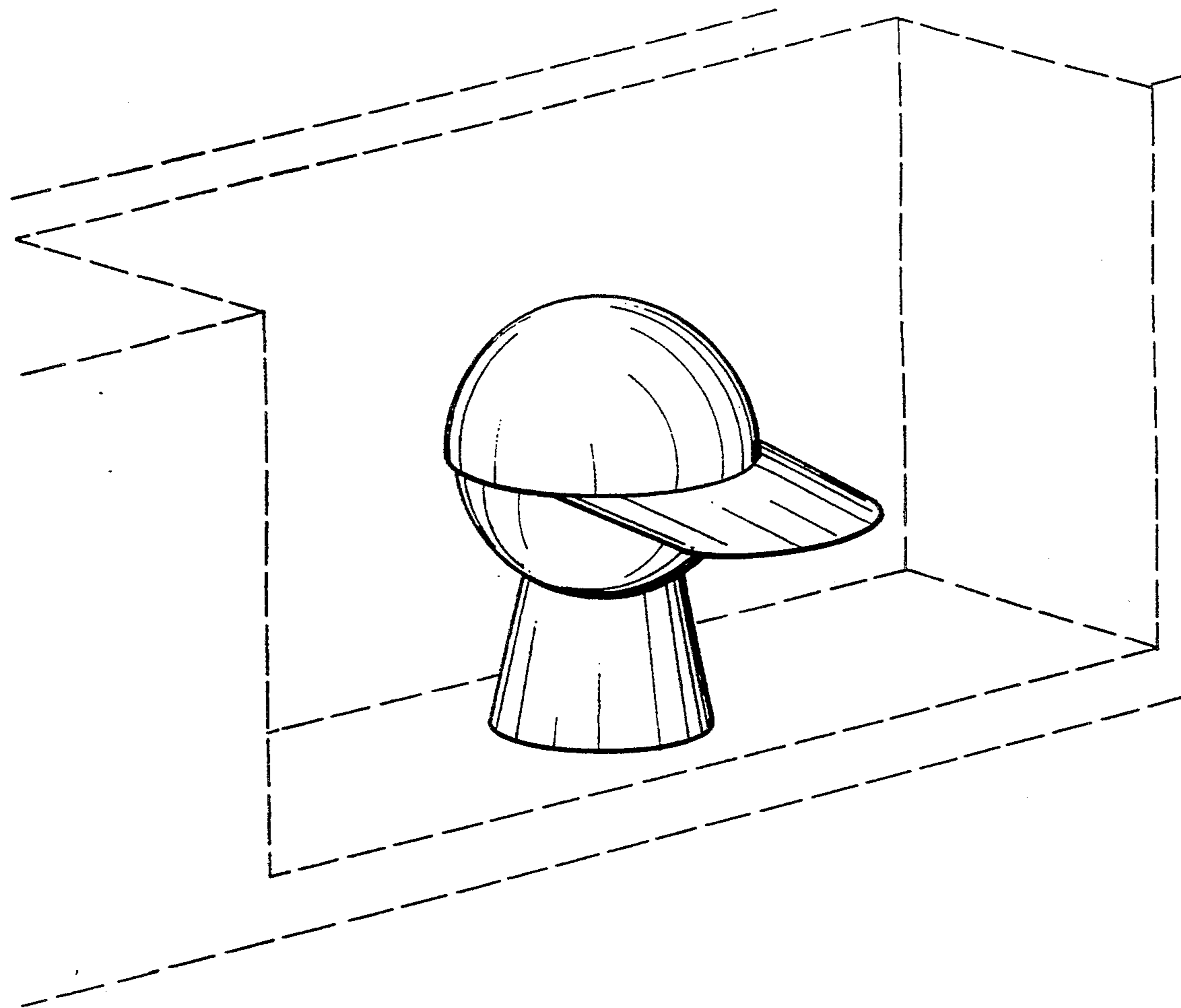

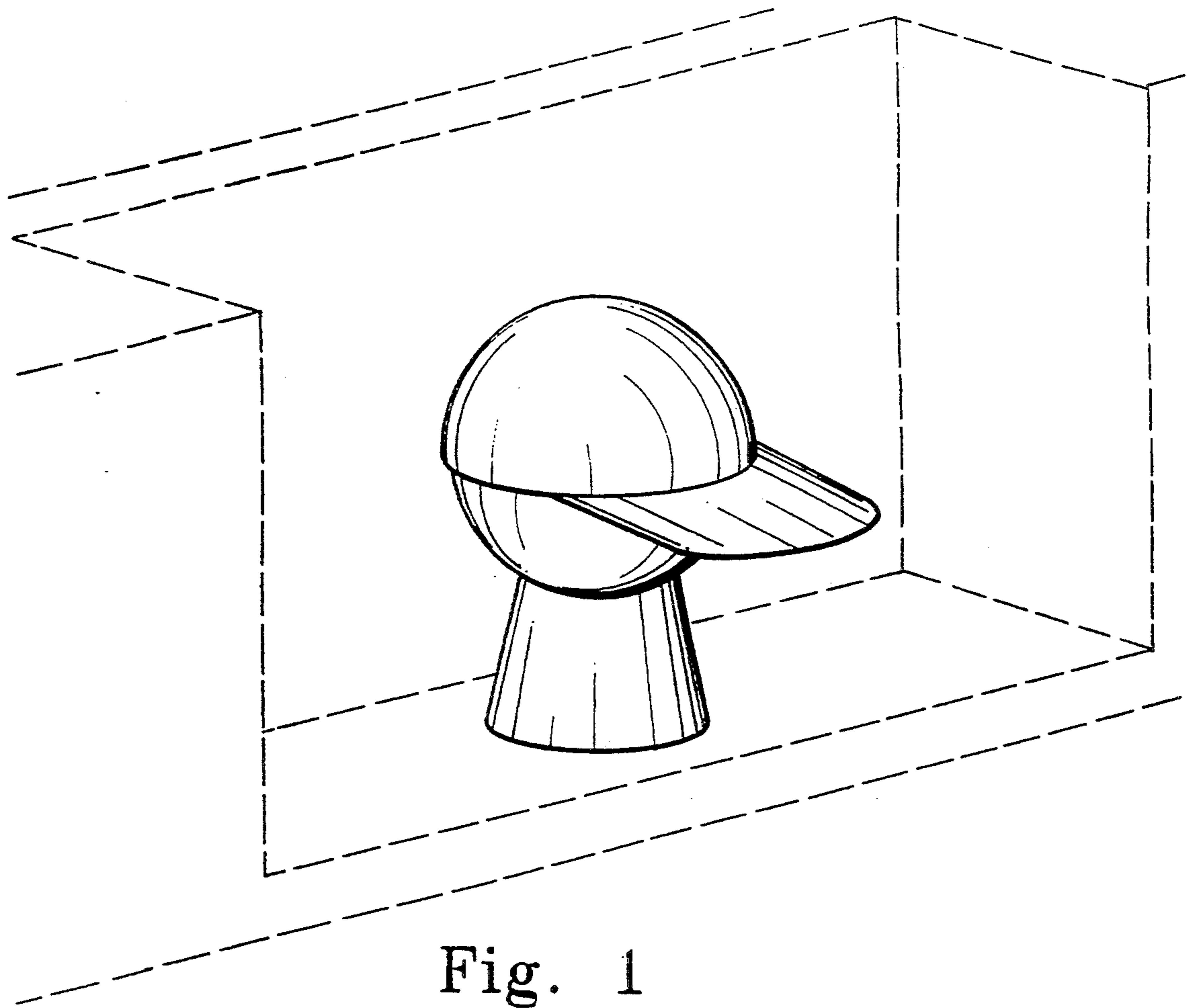

Fig. 1

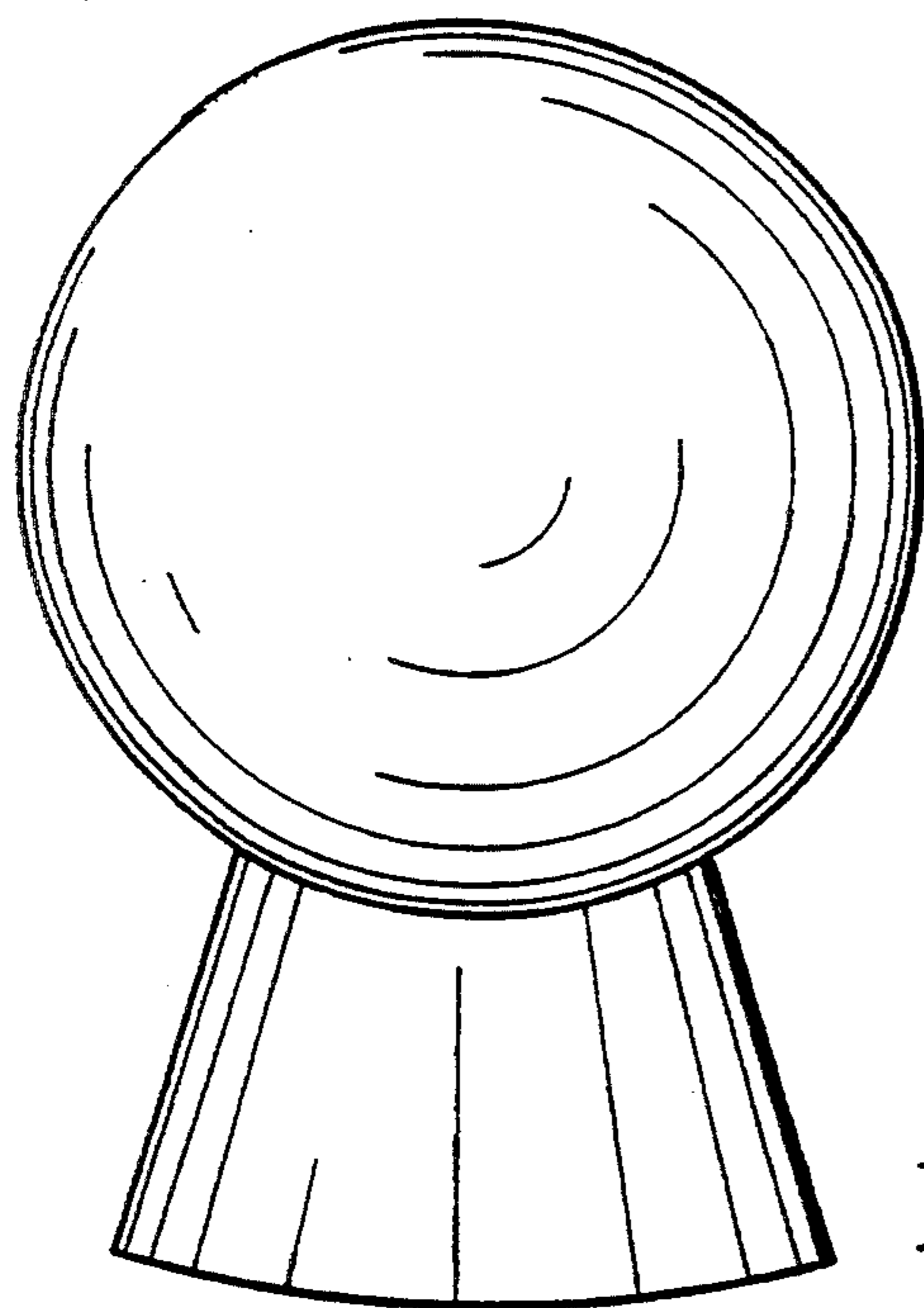

Fig. 2

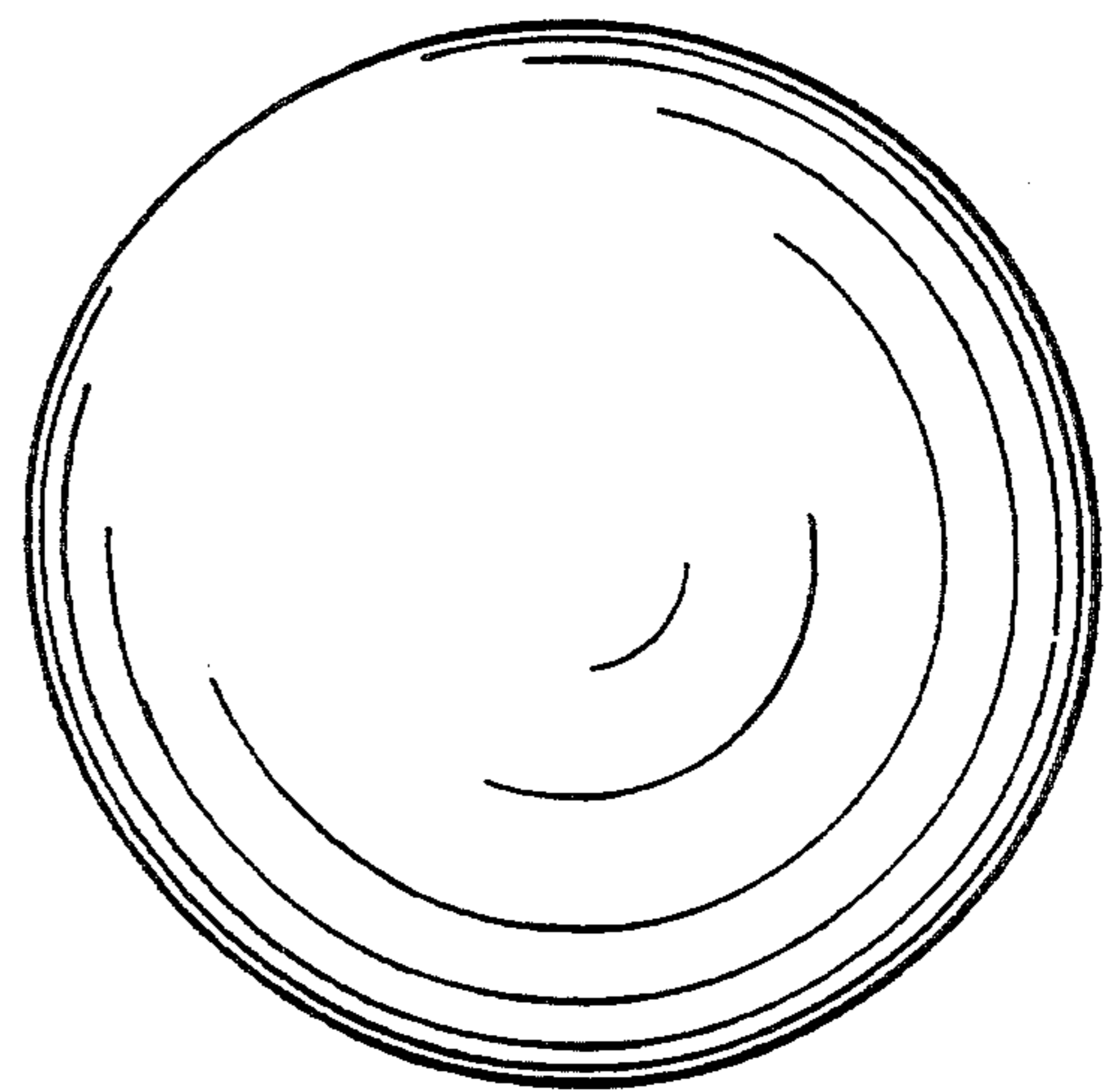

Fig. 3

Fig. 4

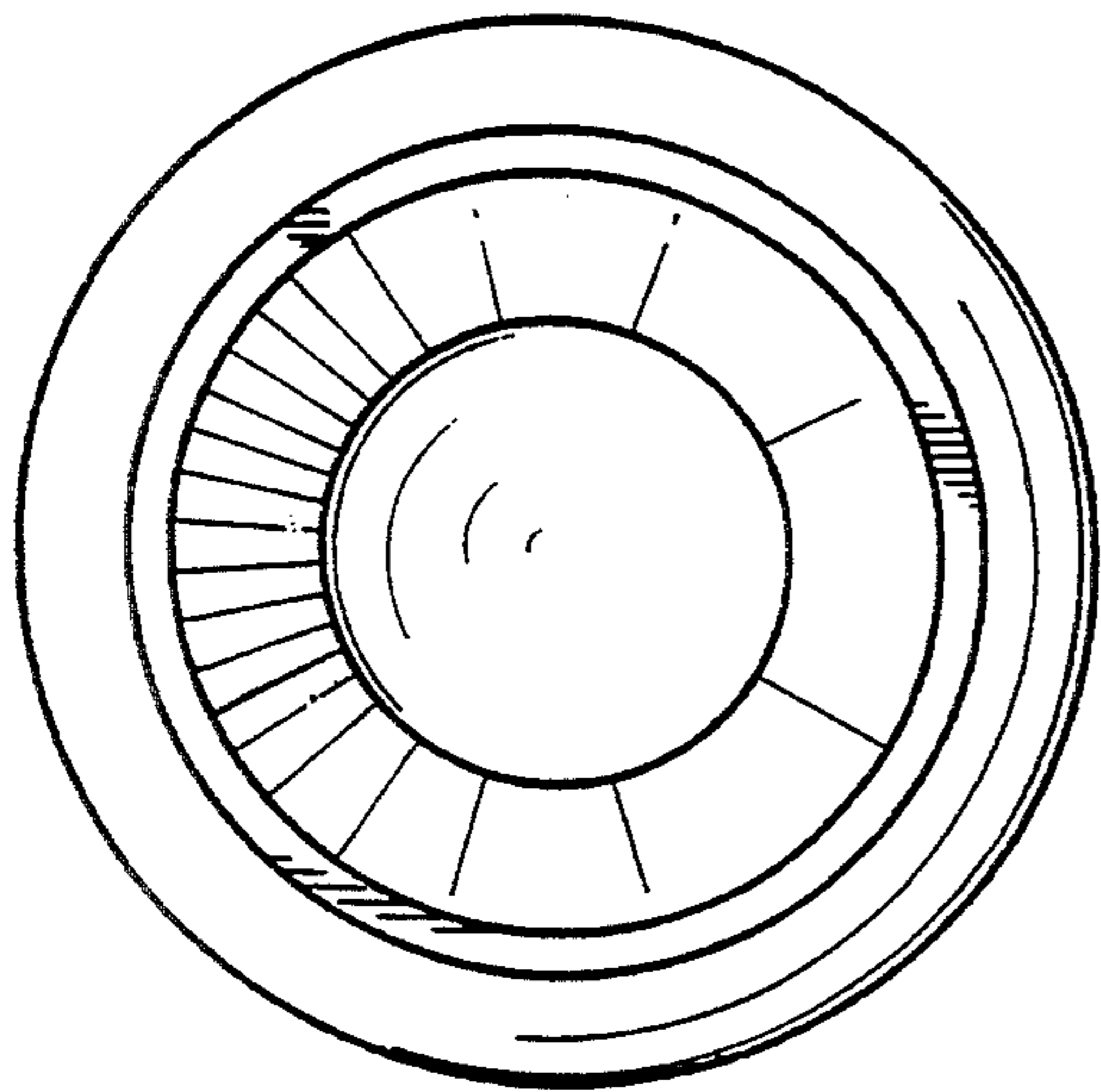

Fig. 5

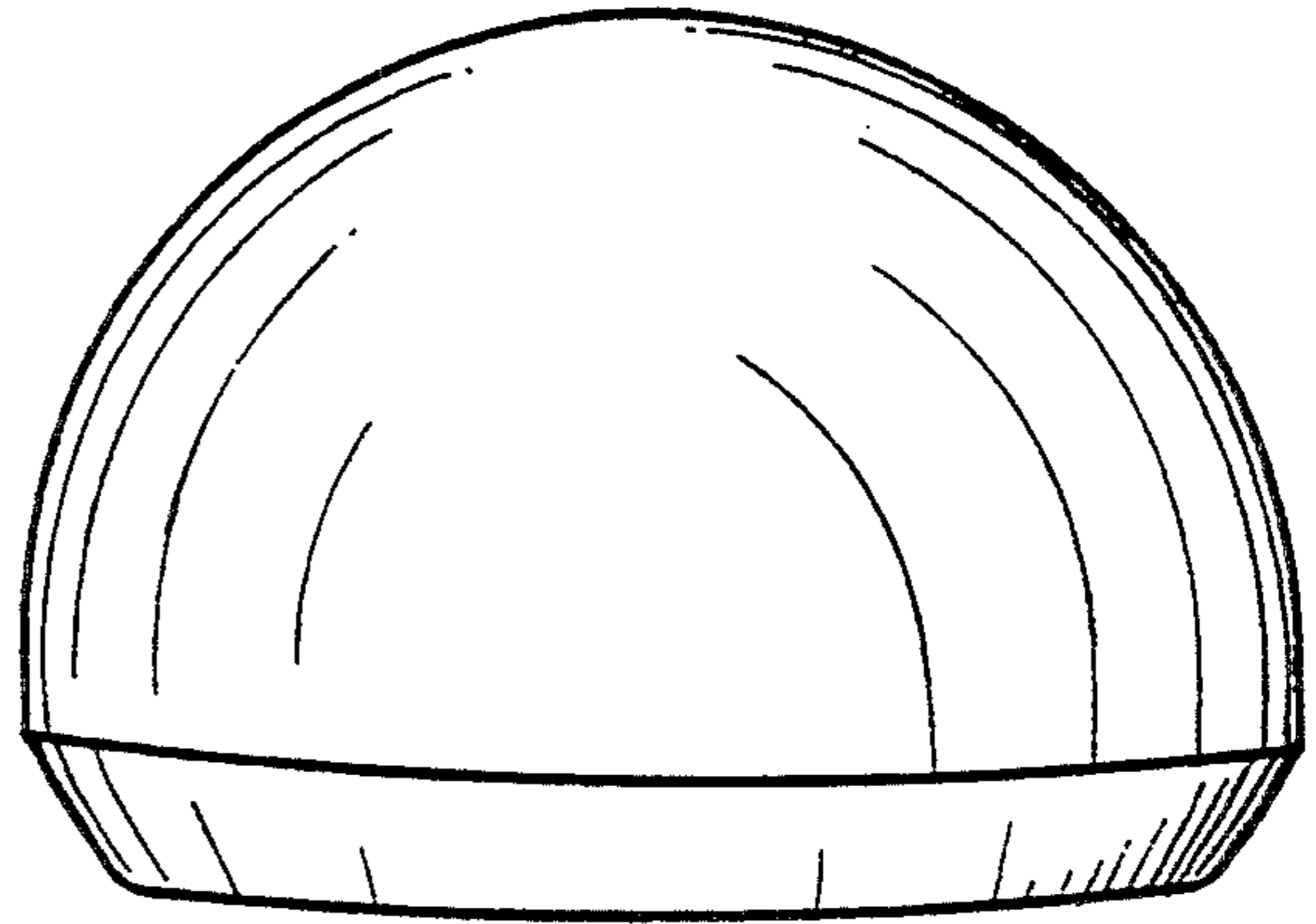

Fig. 7

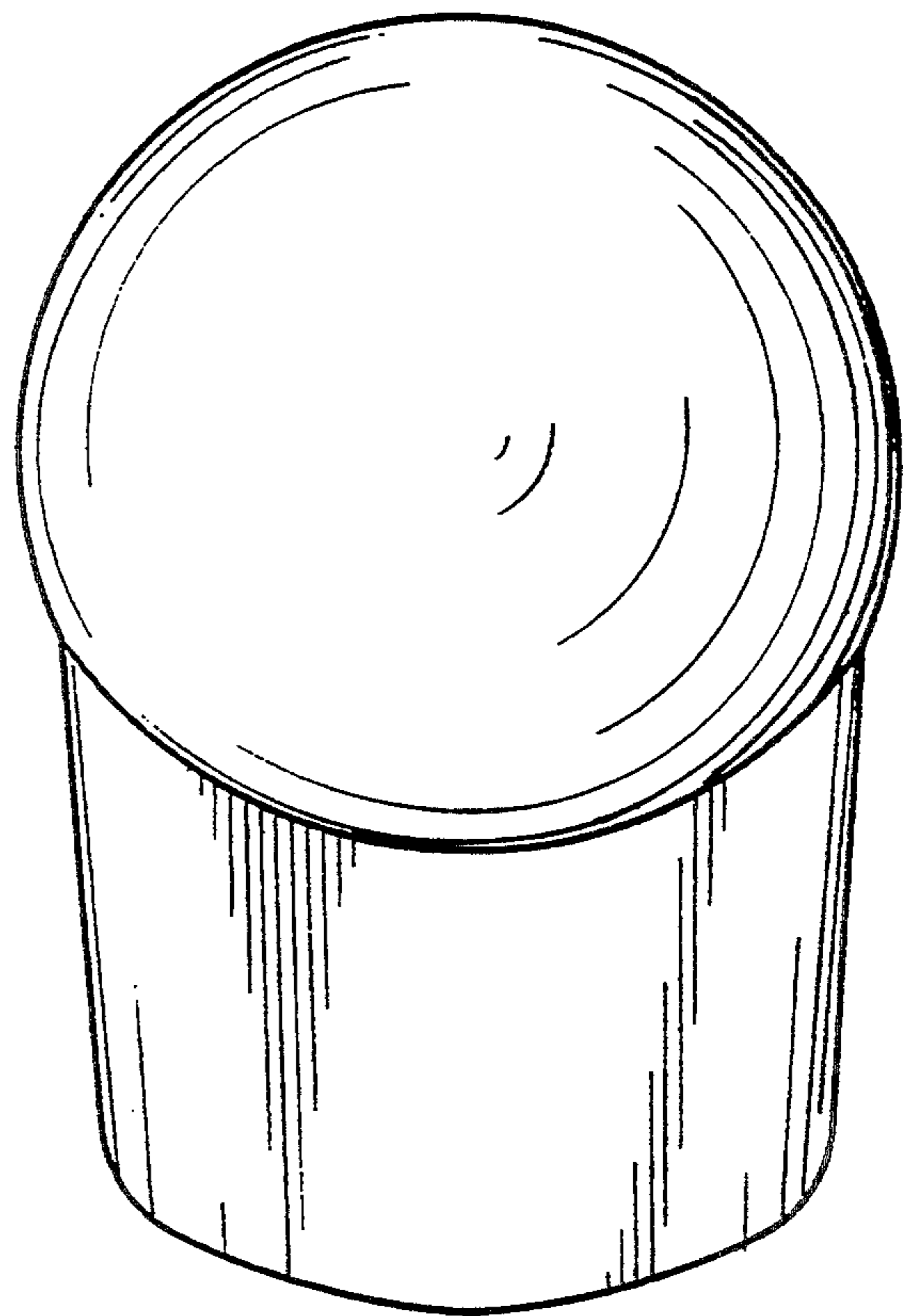

Fig. 6

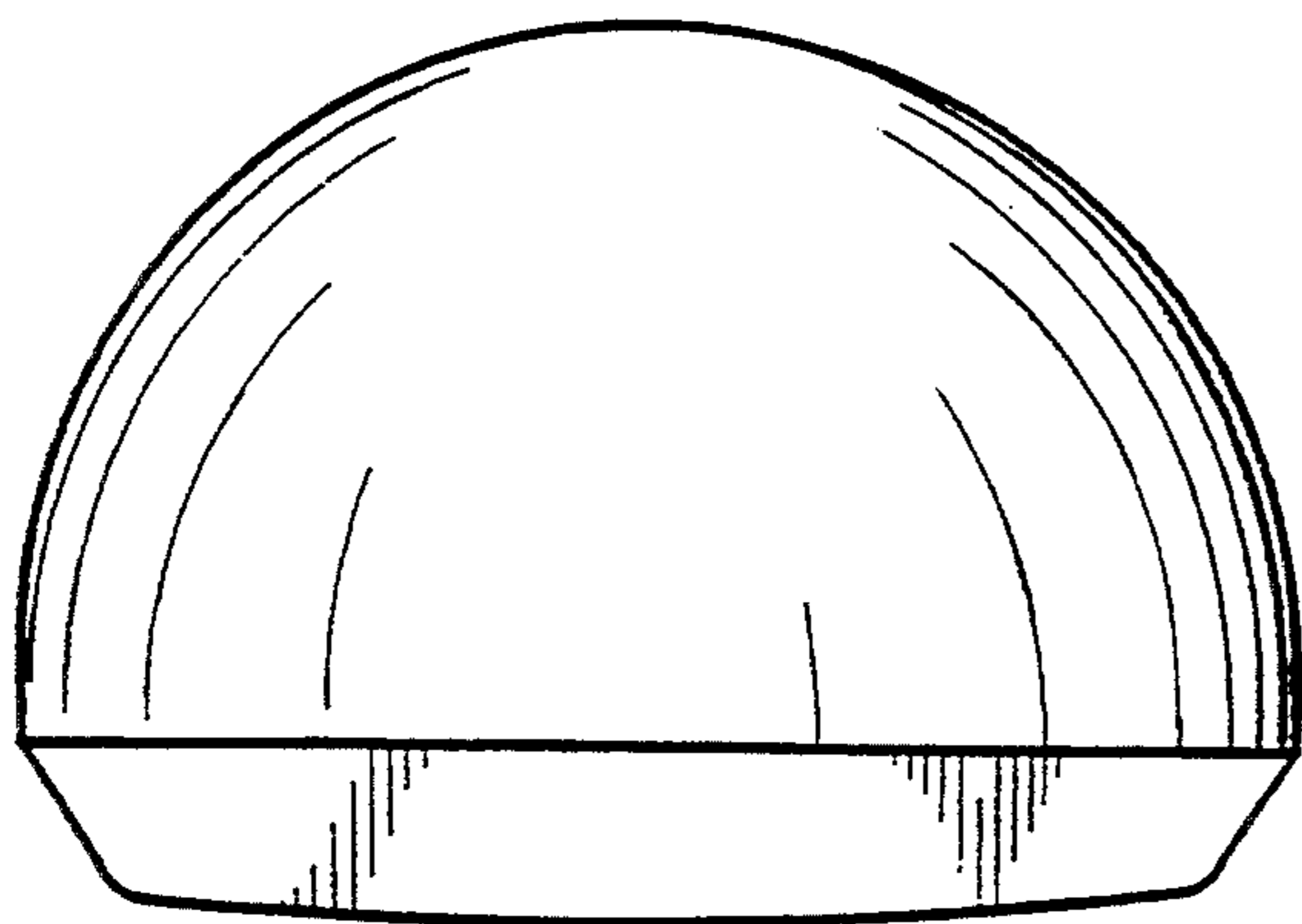

Fig. 8

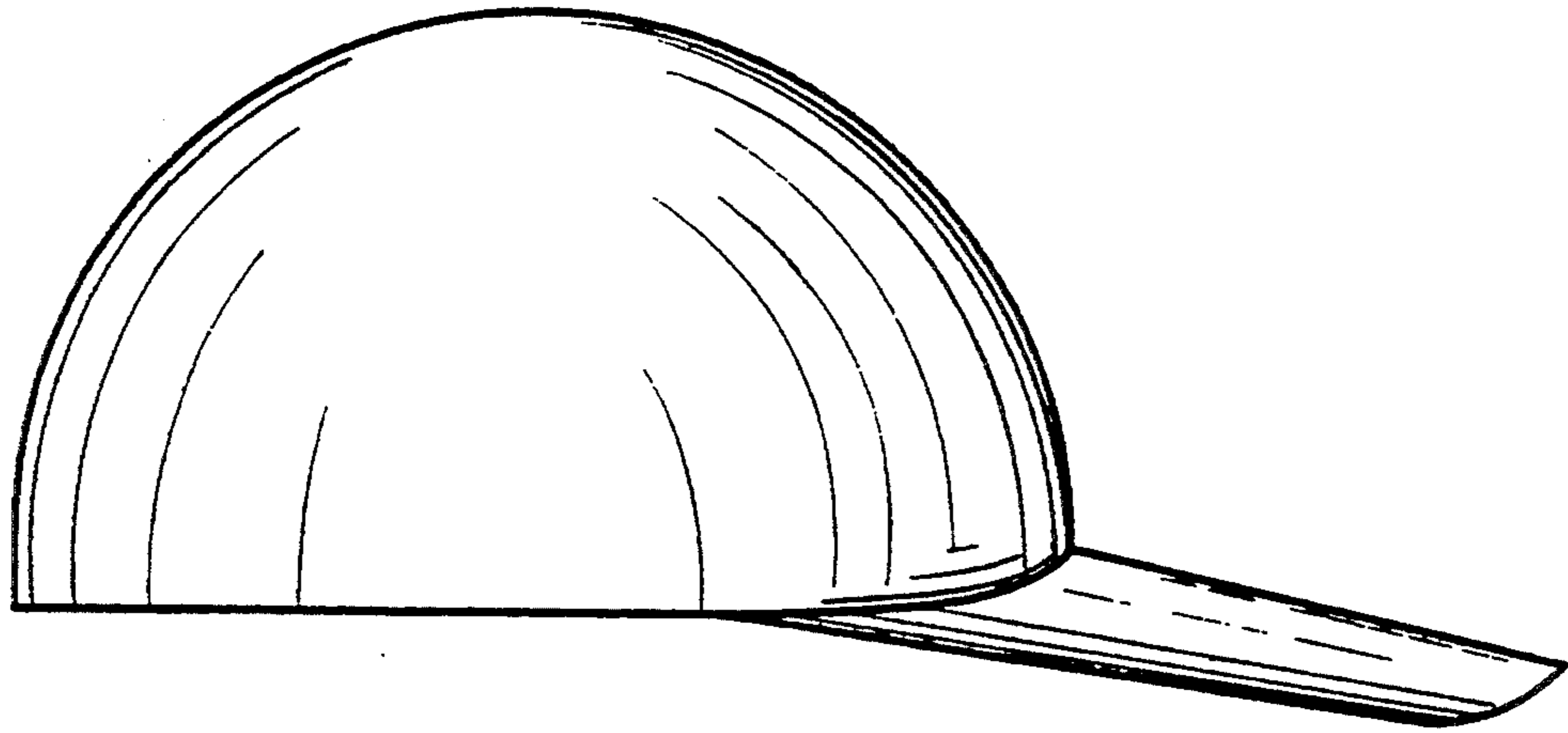

Fig. 9

