



US00D358570S

United States Patent [19]

[11] Patent Number: **Des. 358,570**

Doherty et al.

[45] Date of Patent: **** May 23, 1995**

[54] **TRAILER HITCH AND TOW BAR FOR PERSONAL WATERCRAFT**

4,353,563	10/1982	Foster	280/24
4,768,803	9/1988	Hewitt et al.	280/462
4,856,799	8/1989	Hawn	280/24
5,088,754	2/1992	Sketton	280/491.3
5,232,240	8/1993	Johnson	280/491.4

[75] Inventors: **Mark Doherty; Kim Healy**, both of San Diego, Calif.

[73] Assignee: **D&H Products**, San Diego, Calif.

Primary Examiner—James M. Gandy
Assistant Examiner—M. Brown
Attorney, Agent, or Firm—Brown, Martin, Haller & McClain

[**] Term: **14 Years**

[21] Appl. No.: **17,796**

[57] **CLAIM**

[22] Filed: **Jan. 24, 1994**

[52] U.S. Cl. **D12/162**

The ornamental design for a trailer hitch and tow bar for personal watercraft, as shown.

[58] Field of Search D12/162; 280/24, 402, 280/414.1, 420, 462, 491.1-491.5, 492, 493

DESCRIPTION

[56] **References Cited**

U.S. PATENT DOCUMENTS

D. 214,787	7/1969	Whisnard	D12/162
3,781,038	12/1973	Backel et al.	D12/162

FIG. 1 is a perspective view of a trailer hitch and tow bar for personal watercraft showing our new design; FIG. 2 is a side rear end view thereof; FIG. 3 is a bottom plan view thereof; and, FIG. 4 is a side elevational view thereof.

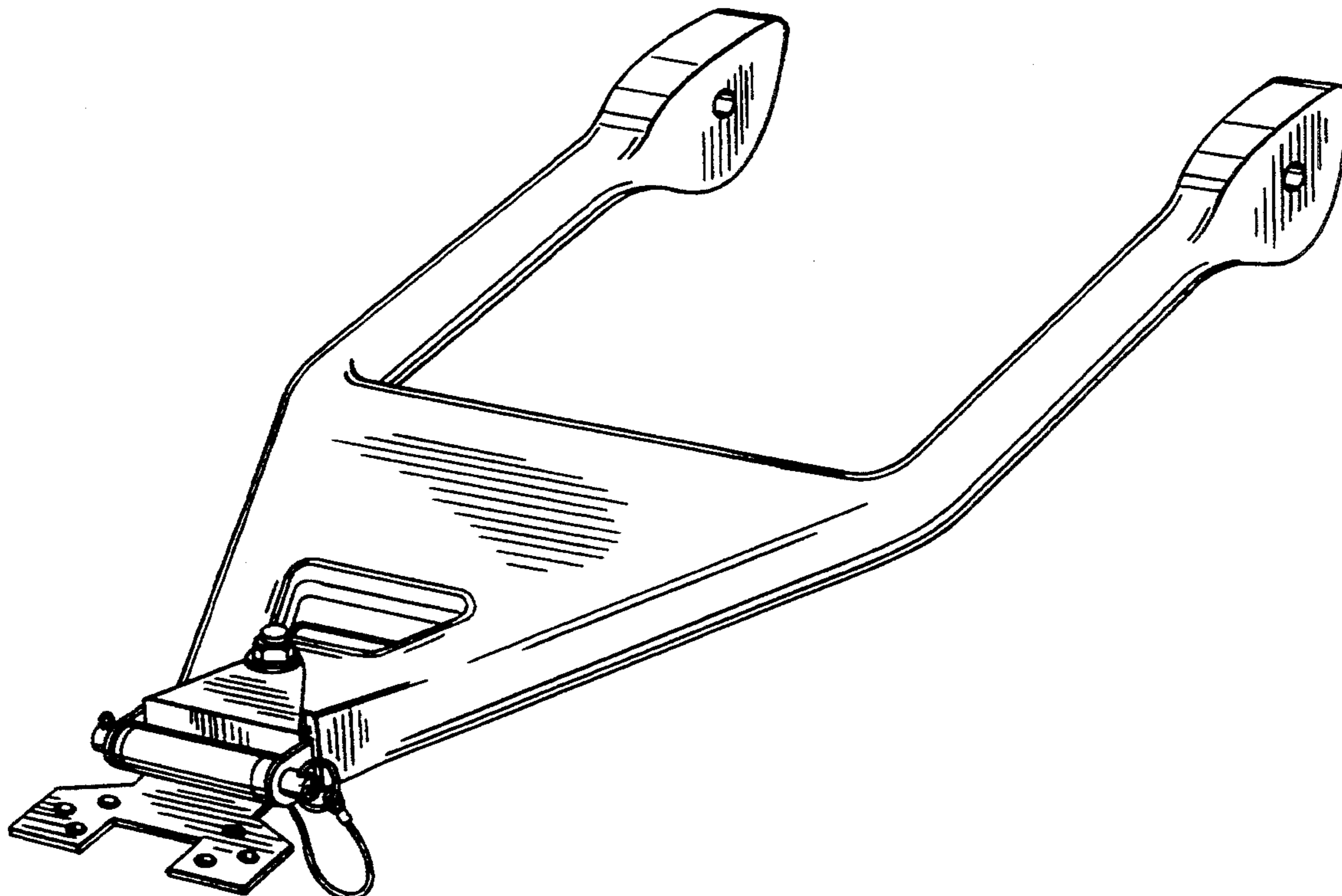

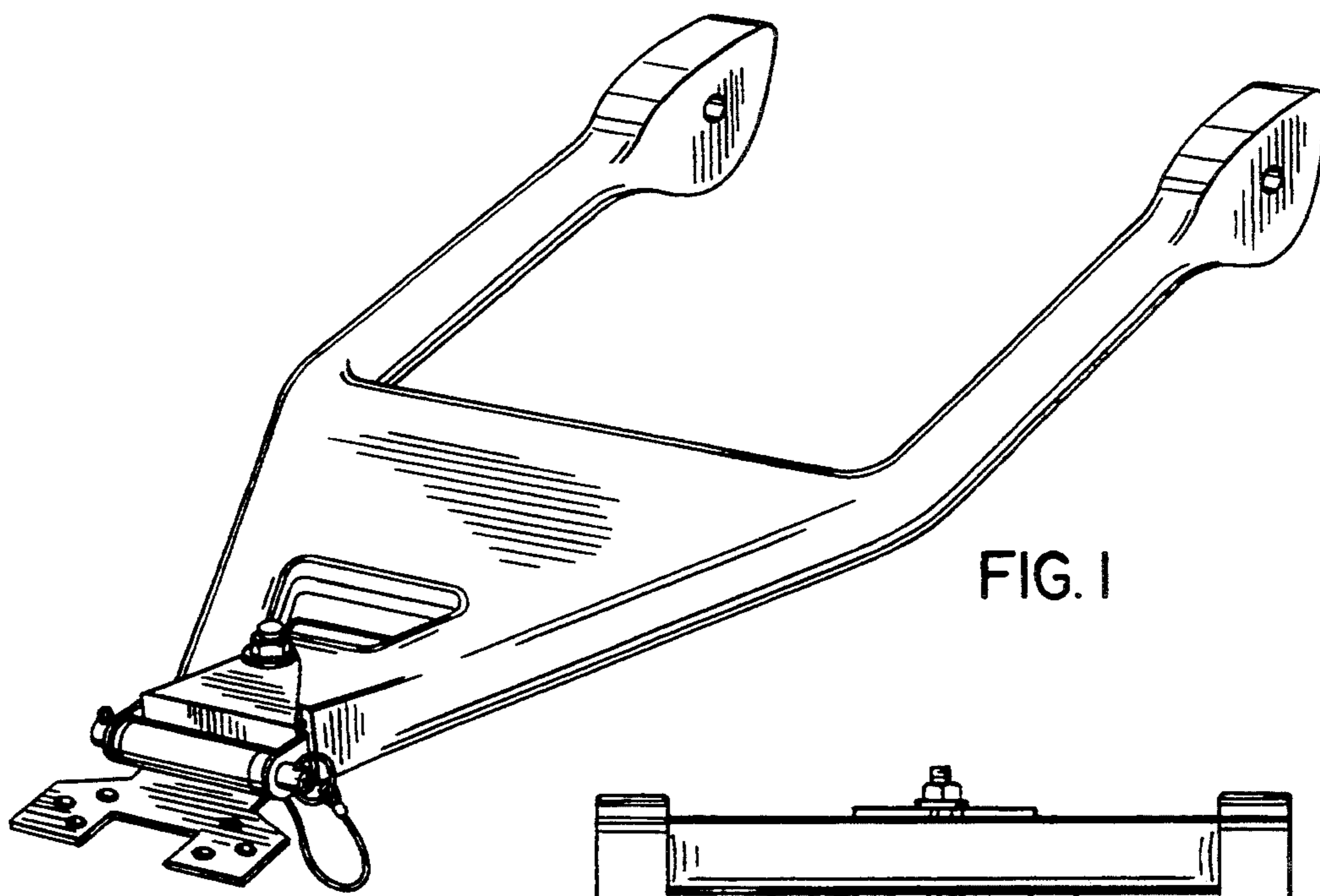

FIG. 1

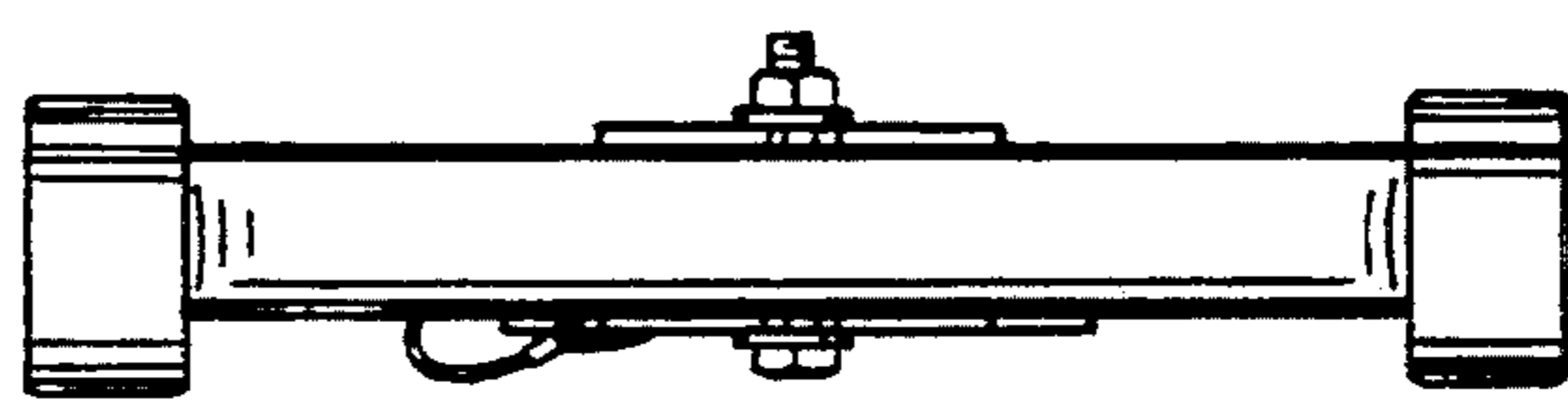

FIG. 2

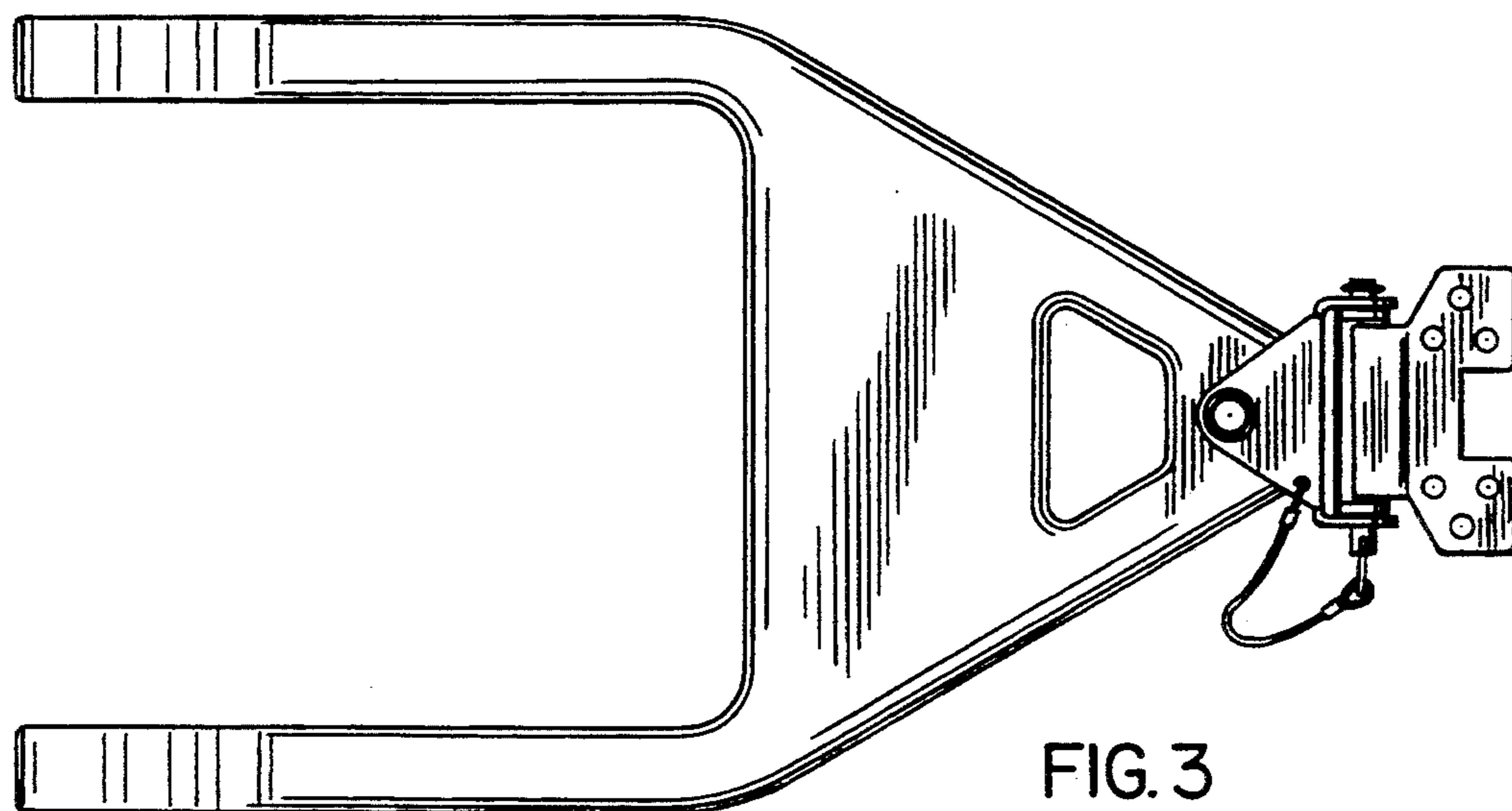

FIG. 3

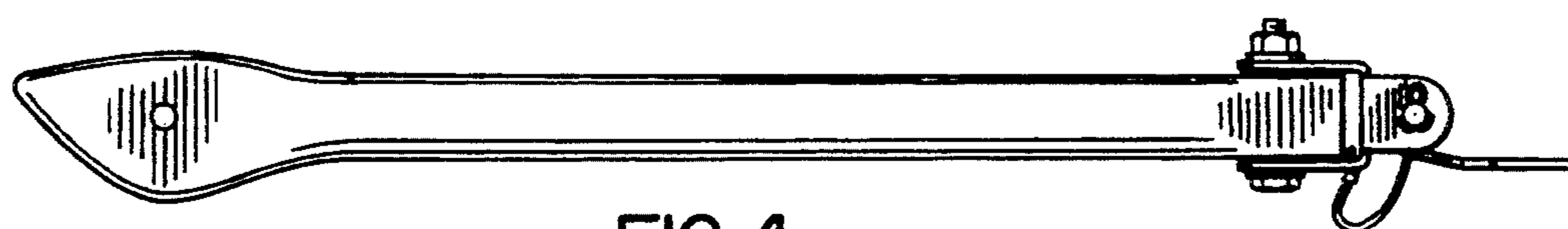

FIG. 4