



US00D358368S

# United States Patent [19]

[11] Patent Number: Des. 358,368

Howard et al.

[45] Date of Patent: \*\* May 16, 1995

[54] GROUND FAULT CIRCUIT INTERRUPT UNIT

[75] Inventors: Carol Z. Howard, Oxford; Ward E. Strang, Fairfield, both of Conn.

[73] Assignee: Hubbell Incorporated, Orange, Conn.

[\*\*] Term: 14 Years

[21] Appl. No.: 8,988

[22] Filed: Jun. 2, 1993

[52] U.S. Cl. .... D13/160

[58] Field of Search ..... D13/142, 143, 160; 307/115; 361/42, 45, 46, 114, 115

[56] References Cited

U.S. PATENT DOCUMENTS

- D. 290,598 6/1987 Jaffe et al. .... D13/160
- D. 307,579 5/1990 Layne et al. .... D13/171 X
- D. 313,971 1/1991 Rosenbaum et al. .... D13/160

Primary Examiner—Joel Sincavage  
Attorney, Agent, or Firm—Jerry M. Presson; Michael R. Swartz

[57] CLAIM

The ornamental design for a ground fault circuit interrupt unit, as shown and described.

DESCRIPTION

FIG. 1 is a perspective view of a ground fault circuit interrupt unit showing our new design, the broken line showing of the plug, strain reliever and receptacle are included for the purpose of illustrating environmental structure only and form no part of the claimed design; FIG. 2 is a top plan view thereof; FIG. 3 is a front elevational view thereof, the rear elevational view being a mirror image; FIG. 4 is a right side elevational view thereof; FIG. 5 is a bottom plan view thereof; and, FIG. 6 is a left side elevational view thereof.

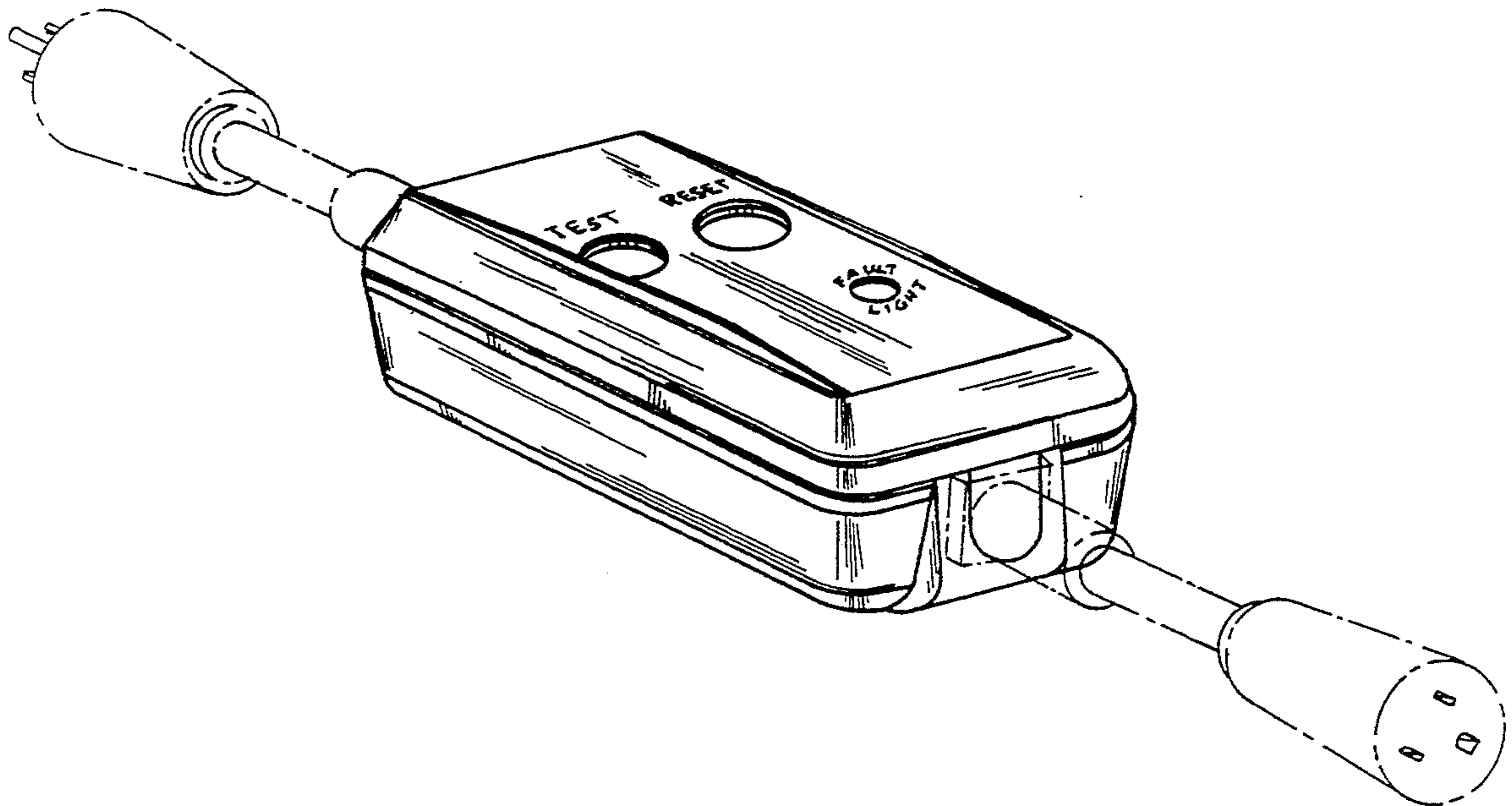

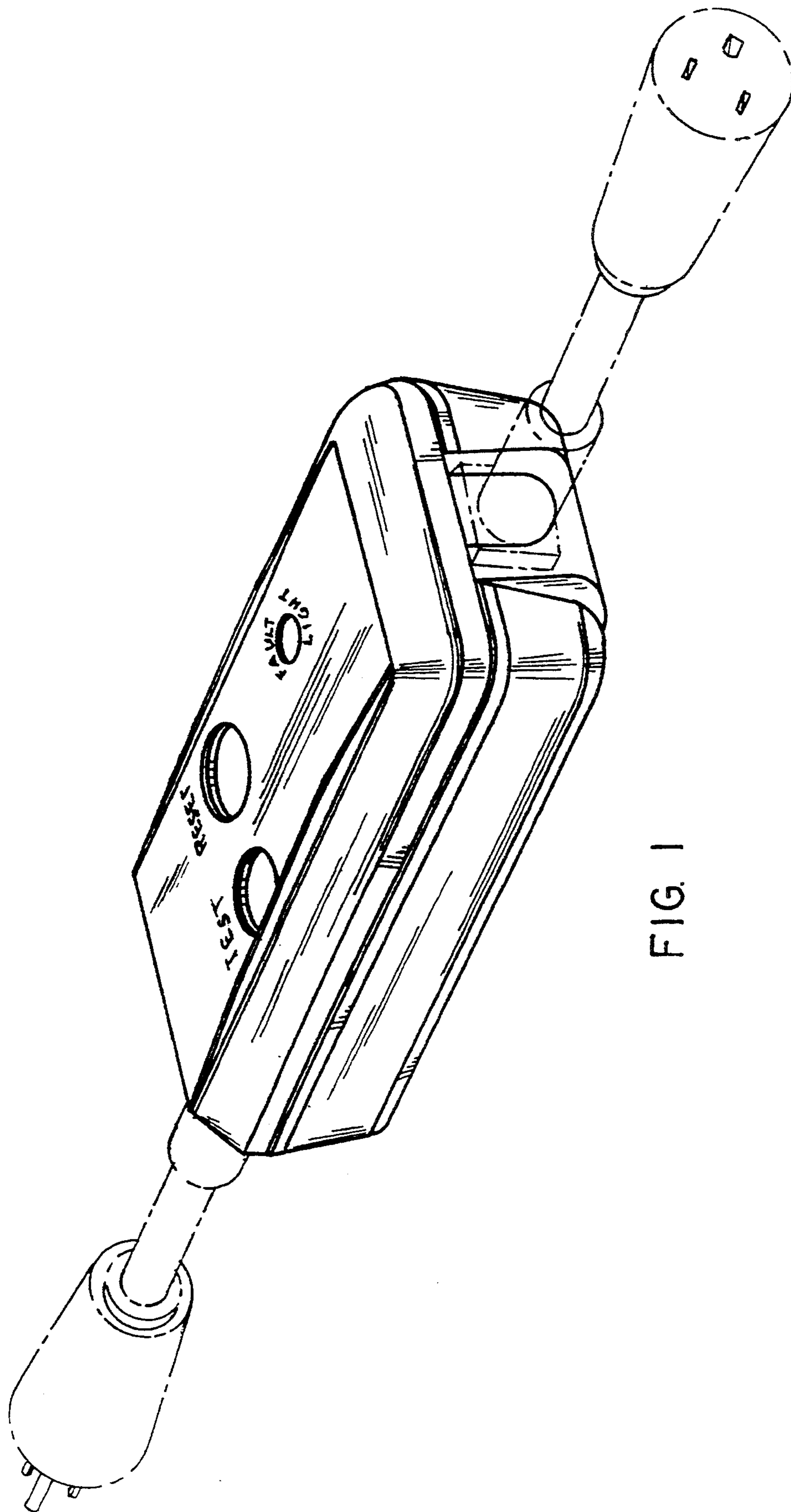

FIG. 1

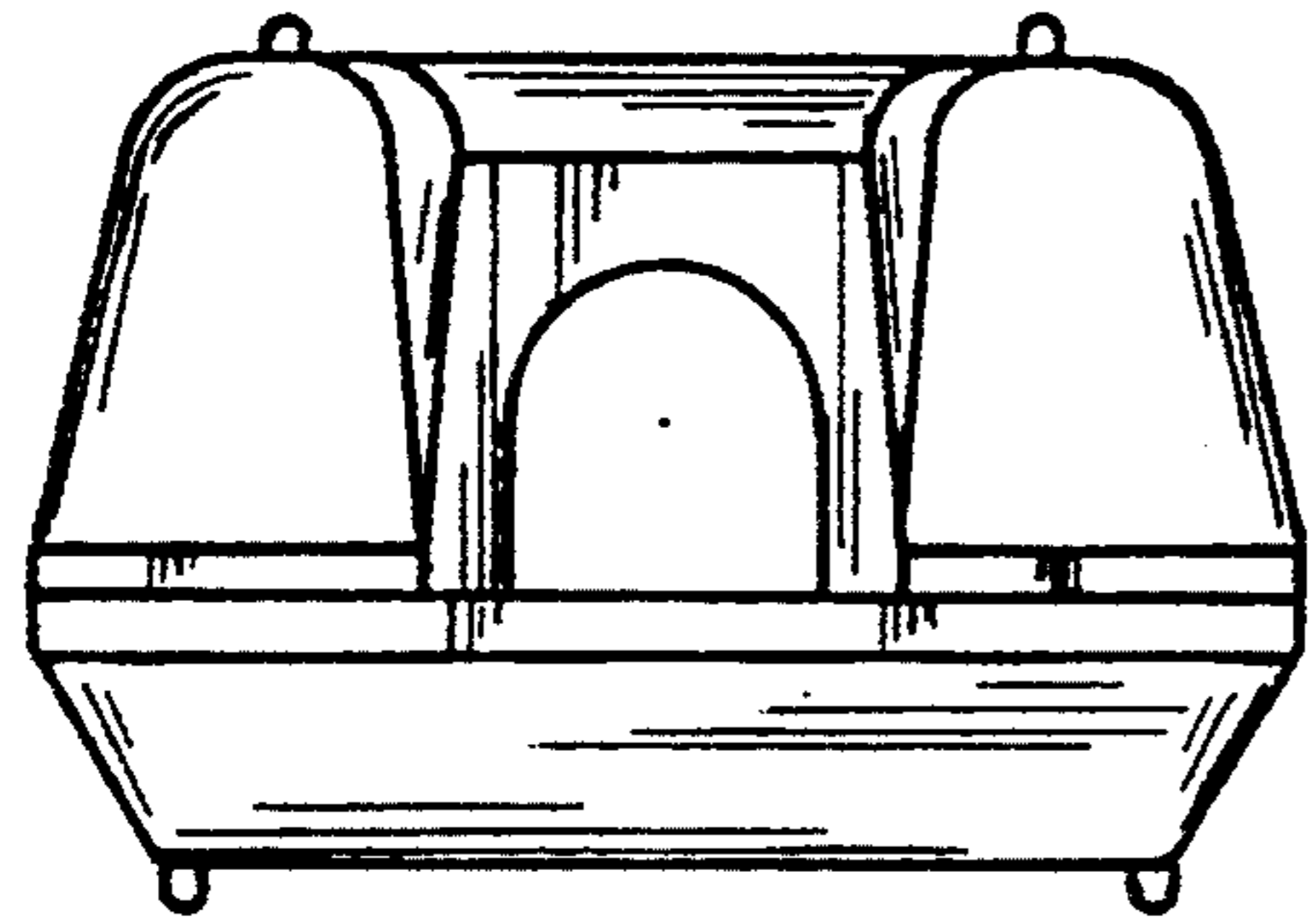

FIG. 4

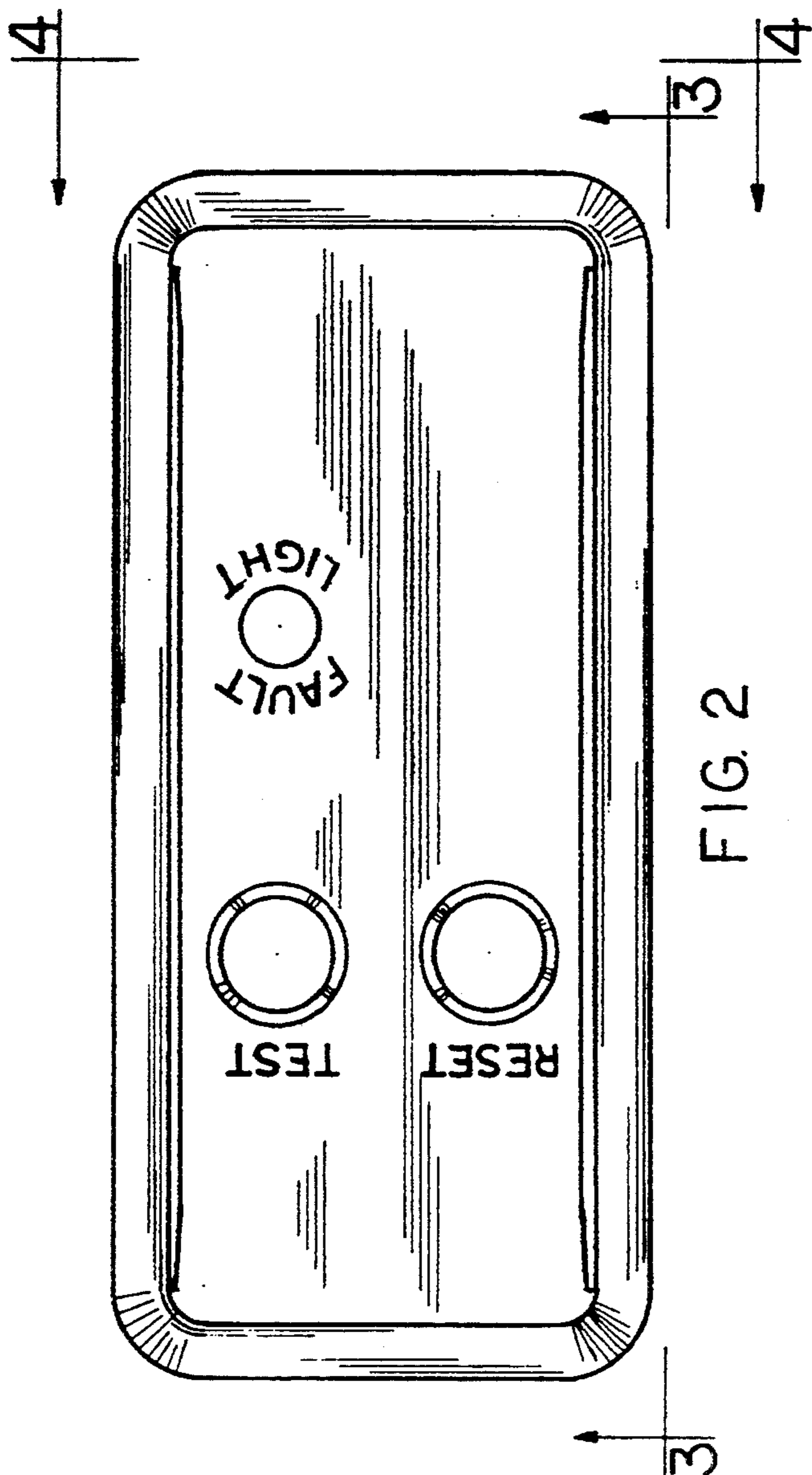

FIG. 2

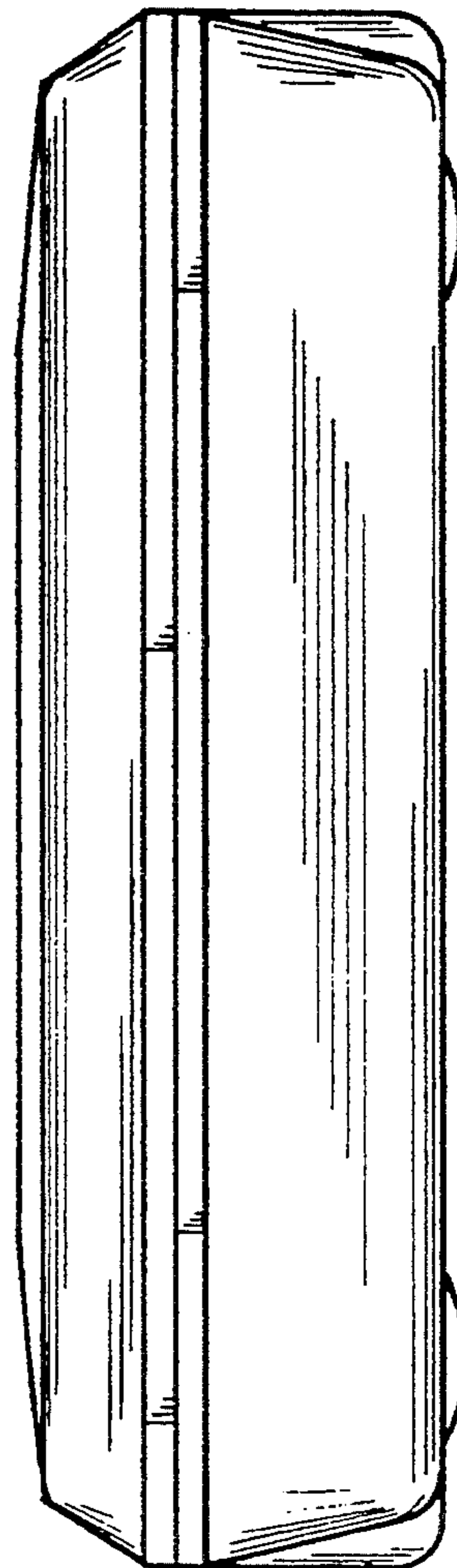

FIG. 3

