



US00D358320S

United States Patent [19]

[11] Patent Number: **Des. 358,320**

Wang

[45] Date of Patent: **** May 16, 1995**

[54] **TWIN-ROLLER LUGGAGE WHEEL**

4,026,570 5/1977 Feinberg 190/18 A

[76] Inventor: **Jin-Sheng Wang**, No. 569,
Ching-Kuo Rd., Ta-Chia Chen,
Taichung Hsien, Taiwan, Prov. of
China

Primary Examiner—Wallace R. Burke
Assistant Examiner—H. Baynham
Attorney, Agent, or Firm—Bacon & Thomas

[**] Term: **14 Years**

[57] **CLAIM**

[21] Appl. No.: **16,588**

The ornamental design for twin-roller luggage wheel,
as shown and described.

[22] Filed: **Dec. 20, 1993**

DESCRIPTION

[52] U.S. Cl. **D8/375**

[58] Field of Search **D8/375; 16/18 R, 18 CG,
16/47; 190/18 A**

FIG. 1 is a perspective view of a twin-roller luggage wheel showing my new design thereof;
FIG. 2 is a front elevational view thereof;
FIG. 3 is a rear elevational view thereof;
FIG. 4 is a left side elevational view thereof;
FIG. 5 is a right side elevational view thereof;
FIG. 6 is a top plan view thereof; and,
FIG. 7 is a bottom plan view thereof.

[56] **References Cited**

U.S. PATENT DOCUMENTS

- D. 275,832 10/1984 **Kotkins, Jr.** **D8/375**
- D. 292,873 11/1987 **Chen** **D8/375**

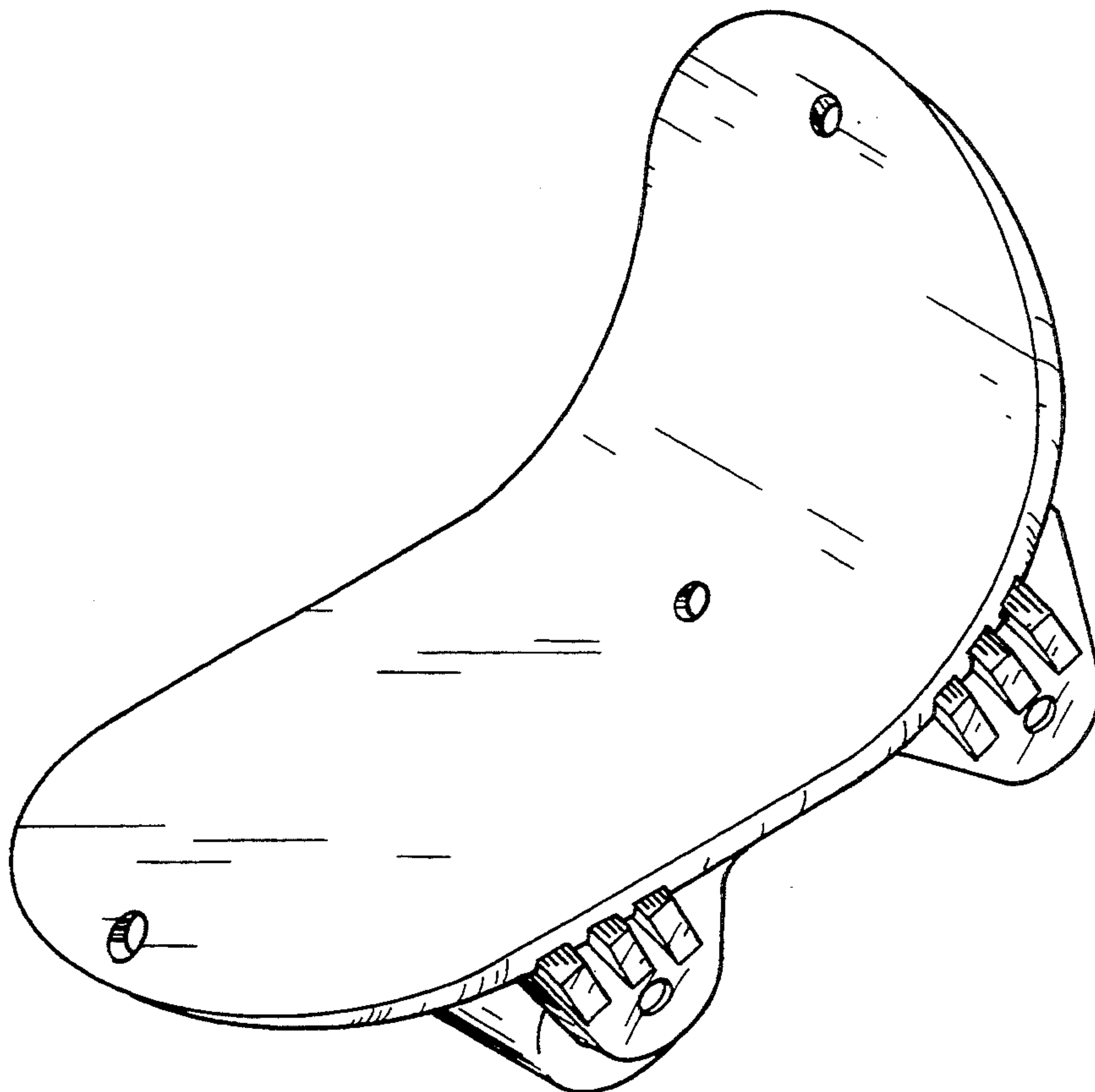

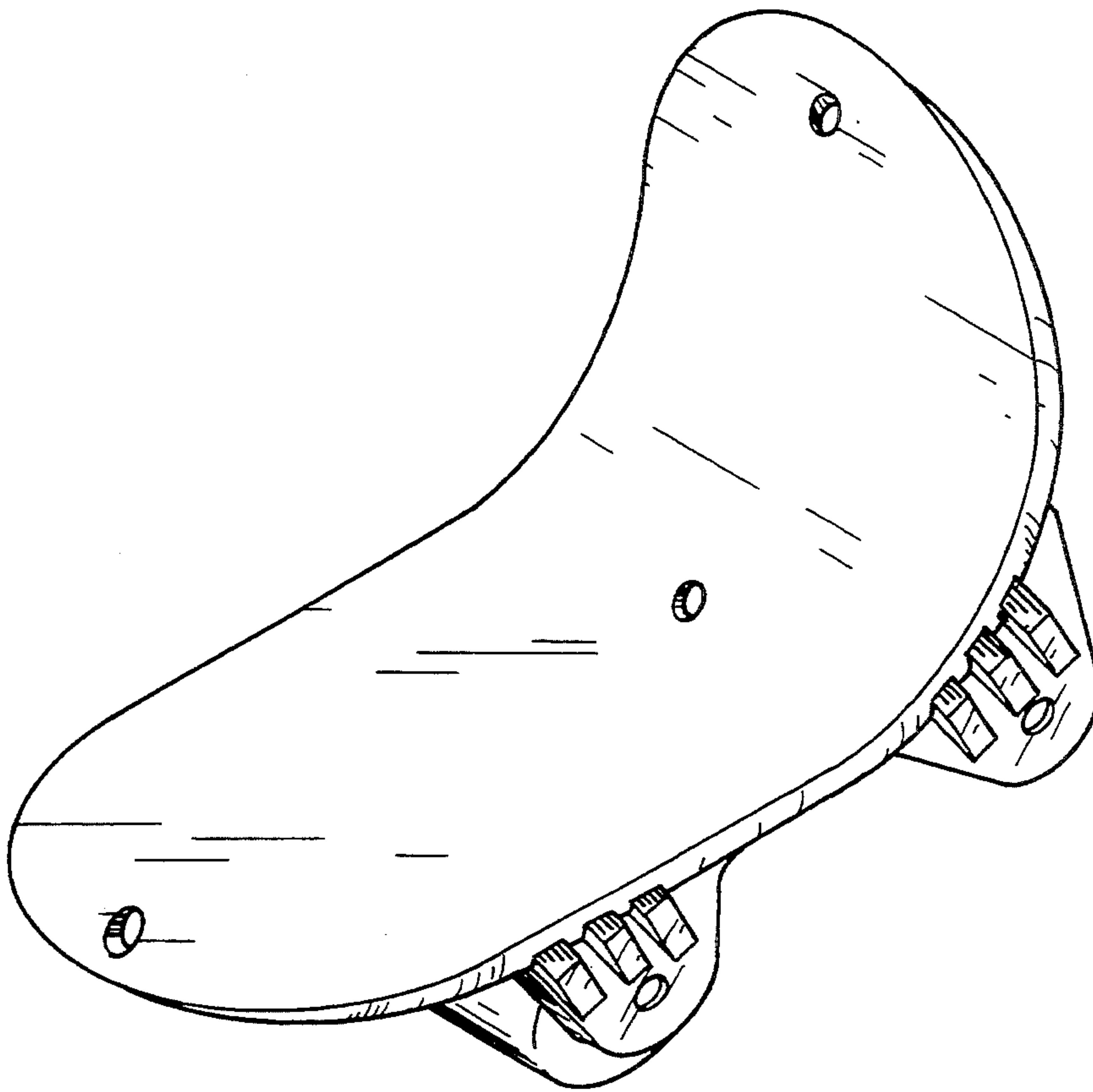

Fig. 1

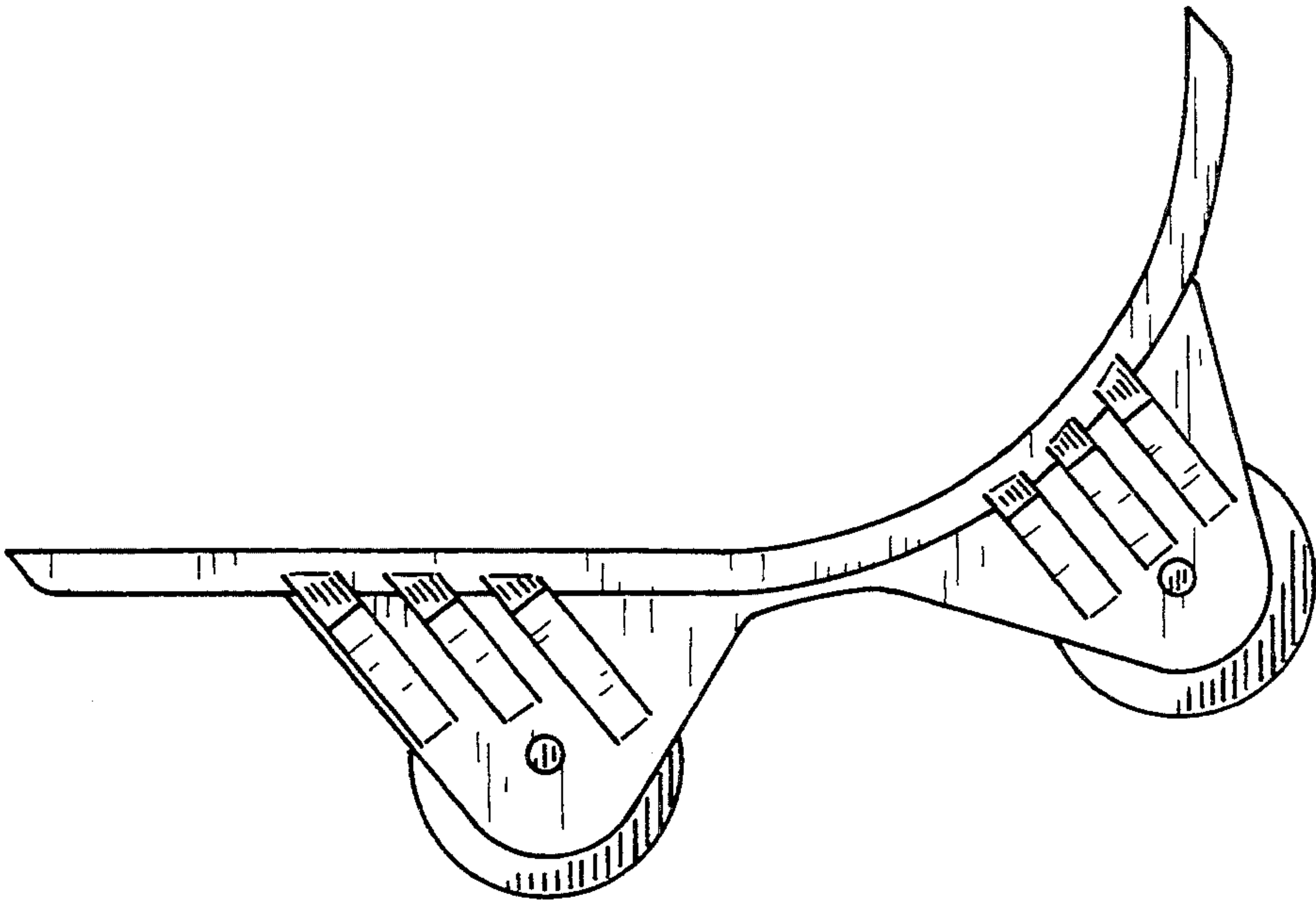

Fig. 2

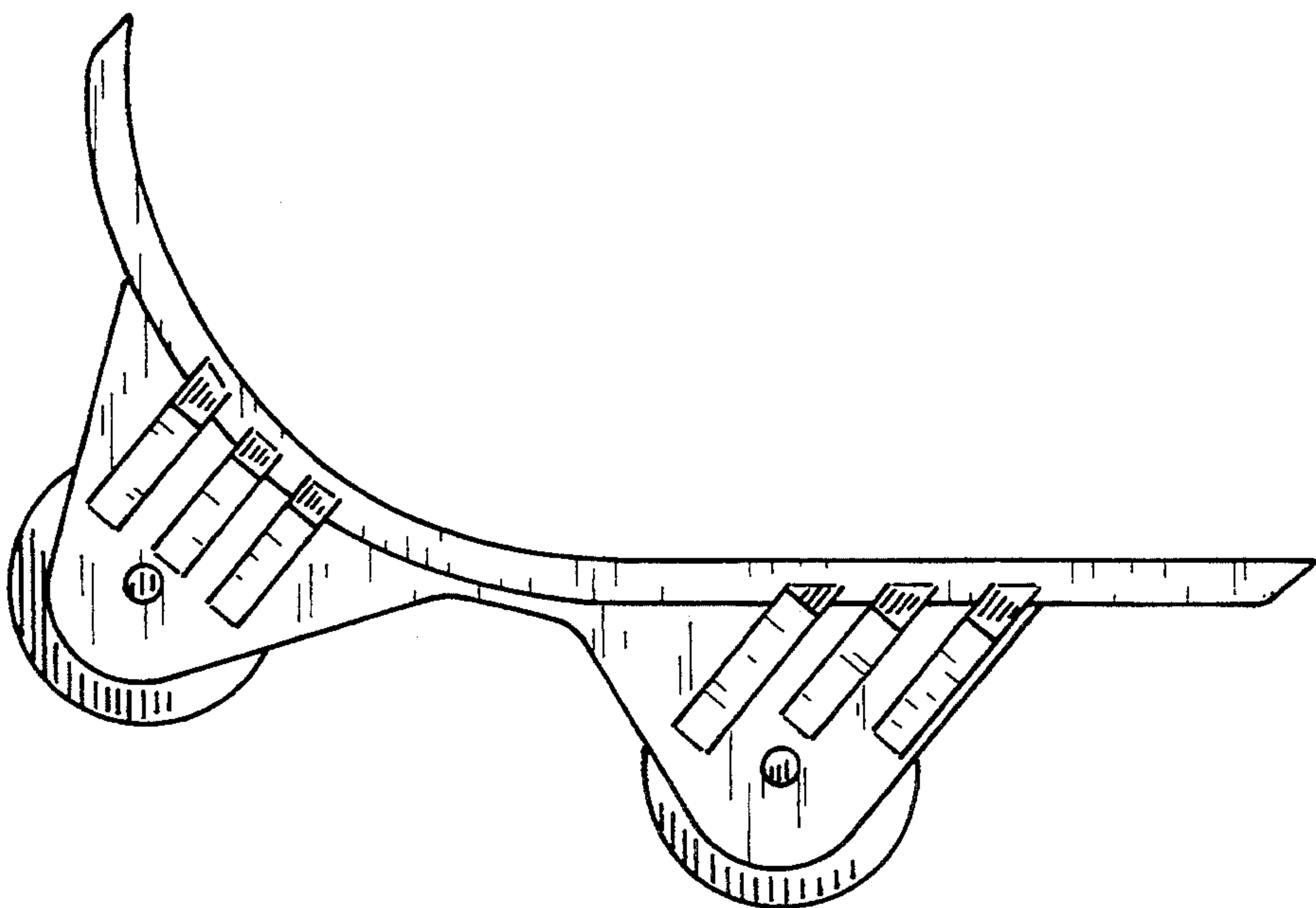

Fig. 3

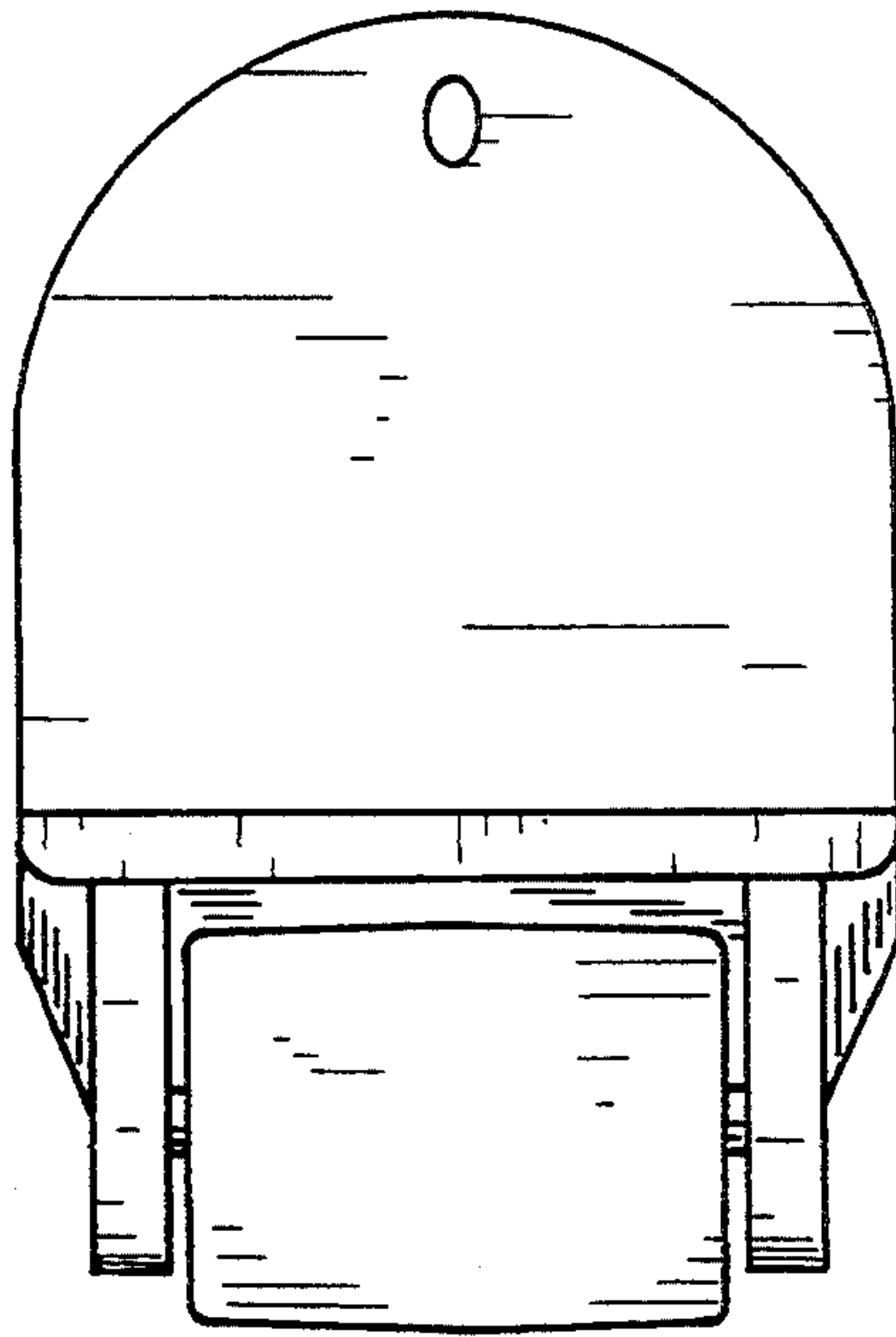

Fig . 4

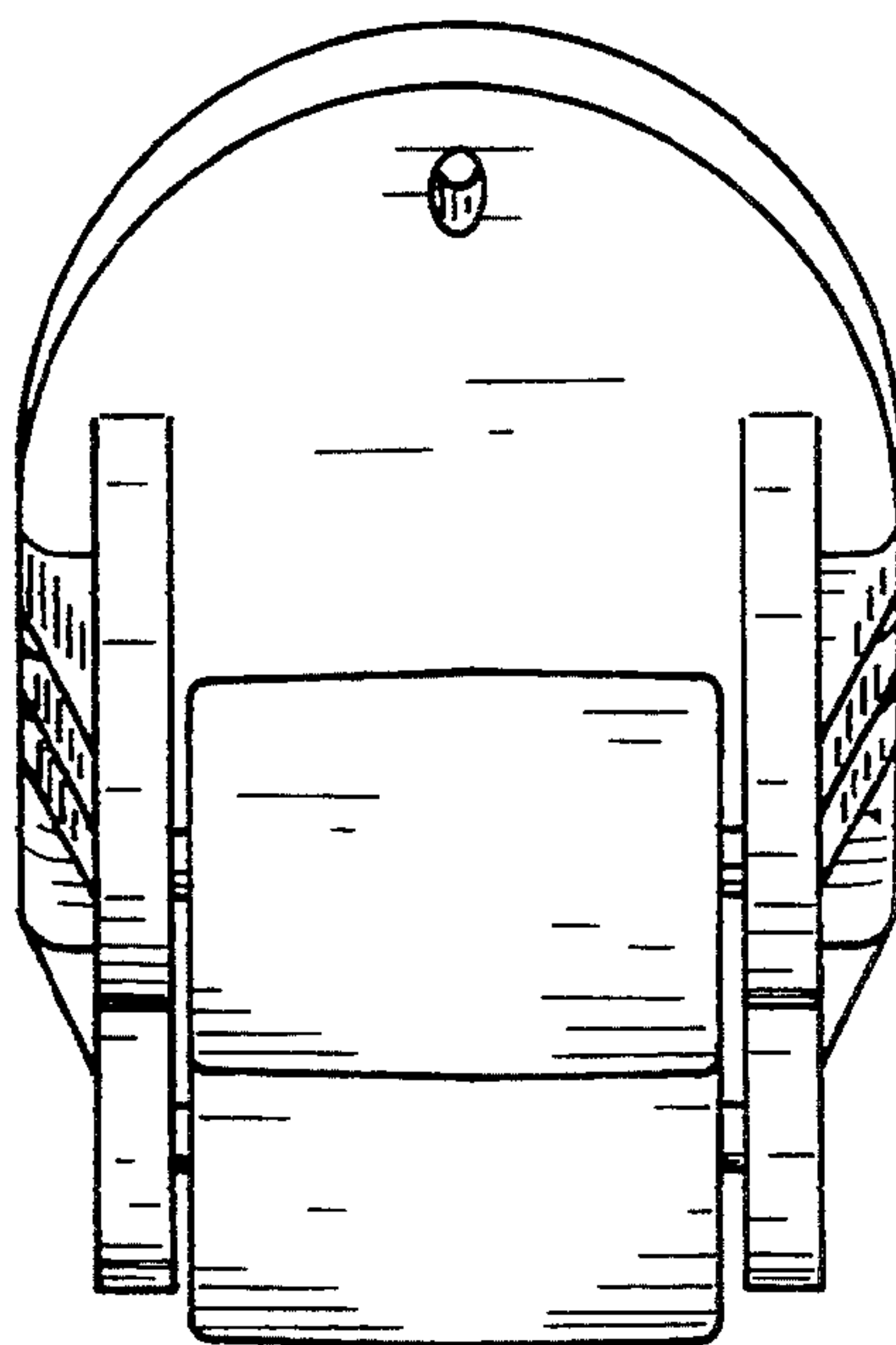

Fig . 5

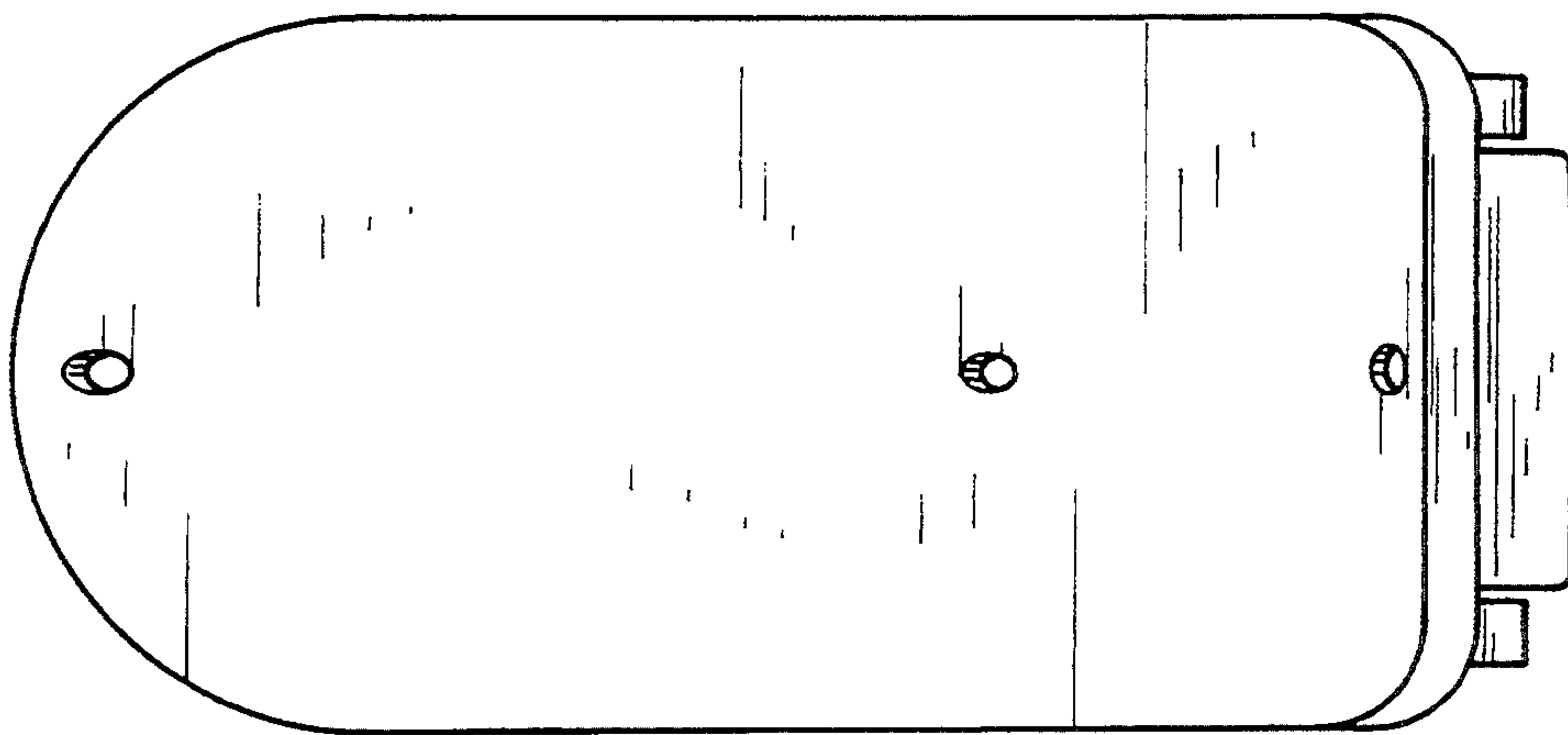

Fig . 6

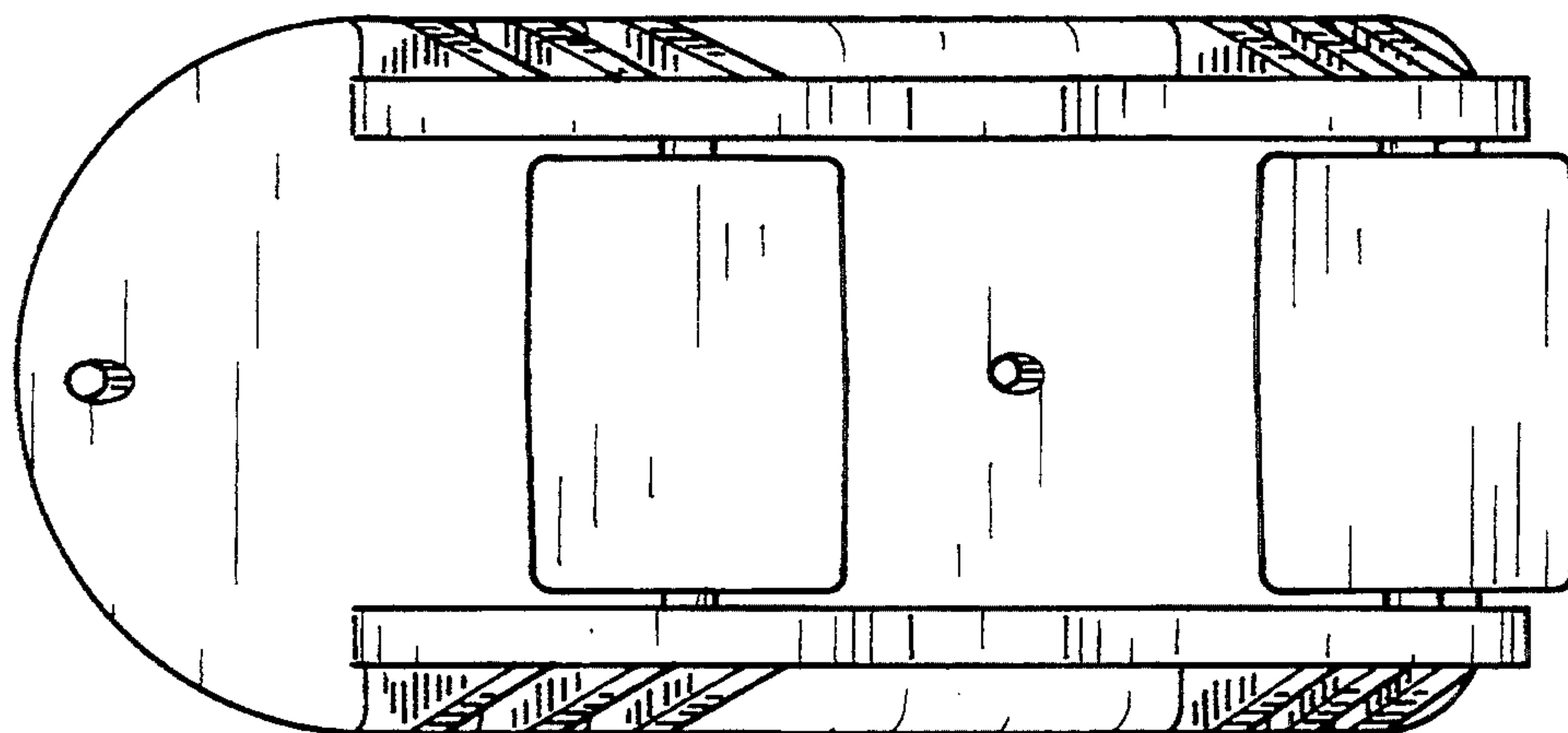

Fig . 7