



US00D358176S

United States Patent [19]

[11] Patent Number: **Des. 358,176**

Atkinson

[45] Date of Patent: **** May 9, 1995**

[54] **ADVERTISING DISPLAY**

[75] Inventor: **Charles M. Atkinson**, Arkadelphia, Ark.

[73] Assignee: **People You Need, Inc.**, Arkadelphia, Ark.

[**] Term: **14 Years**

[21] Appl. No.: **24,344**

[22] Filed: **Jun. 13, 1994**

[52] U.S. Cl. **D20/21; D6/301**

[58] Field of Search **D20/10, 21, 39, 40, D20/41, 44; 40/1, 124, 124.1, 124.2, 124.4, 584, 618, 624, 152, 152.1; D6/300, 301, 302, 303, 304, 305, 306, 307, 308, 309, 310**

4,001,959	1/1977	Grendahl	40/152.1
4,432,151	2/1984	Morris	40/10 D
4,505,059	3/1985	Morris	40/10 D
4,727,666	3/1985	Kyler	40/10 R
4,738,038	4/1988	Tanne et al.	40/10 D
4,839,976	6/1989	Kyler	40/42
4,852,280	8/1989	Beattie	40/124
5,083,391	1/1992	Kyler	40/642
5,280,840	1/1994	Terpening	40/124

Primary Examiner—James M. Gandy
Assistant Examiner—Marcus Jackson
Attorney, Agent, or Firm—Ray F. Cox, Jr.

[57] **CLAIM**

The ornamental design for an “advertising display”, as shown and described.

DESCRIPTION

FIG. 1 is a front elevational view of an advertising display showing my new design; FIG. 2 is a side elevational view thereof; FIG. 3 is a perspective view thereof; FIG. 4 is a top plan view thereof; FIG. 5 is a bottom plan view thereof; FIG. 6 is a front elevational view thereof, with the broken line showing for illustrative purposes only and forming no part of the claimed design; and, FIG. 7 is a perspective view of FIG. 6.

[56] **References Cited**

U.S. PATENT DOCUMENTS

D. 190,523	6/1961	Garbarini	D10/115
933,500	9/1909	Towle	40/124
1,692,404	11/1928	Conwell	40/124.1
1,912,505	6/1933	Weston	40/124.1
1,980,453	11/1934	Tucker et al.	40/124.1
2,499,535	3/1950	Spreen	40/152.1
3,524,274	8/1970	Glassburn	40/124.4
3,789,526	2/1974	Lavinson	40/124

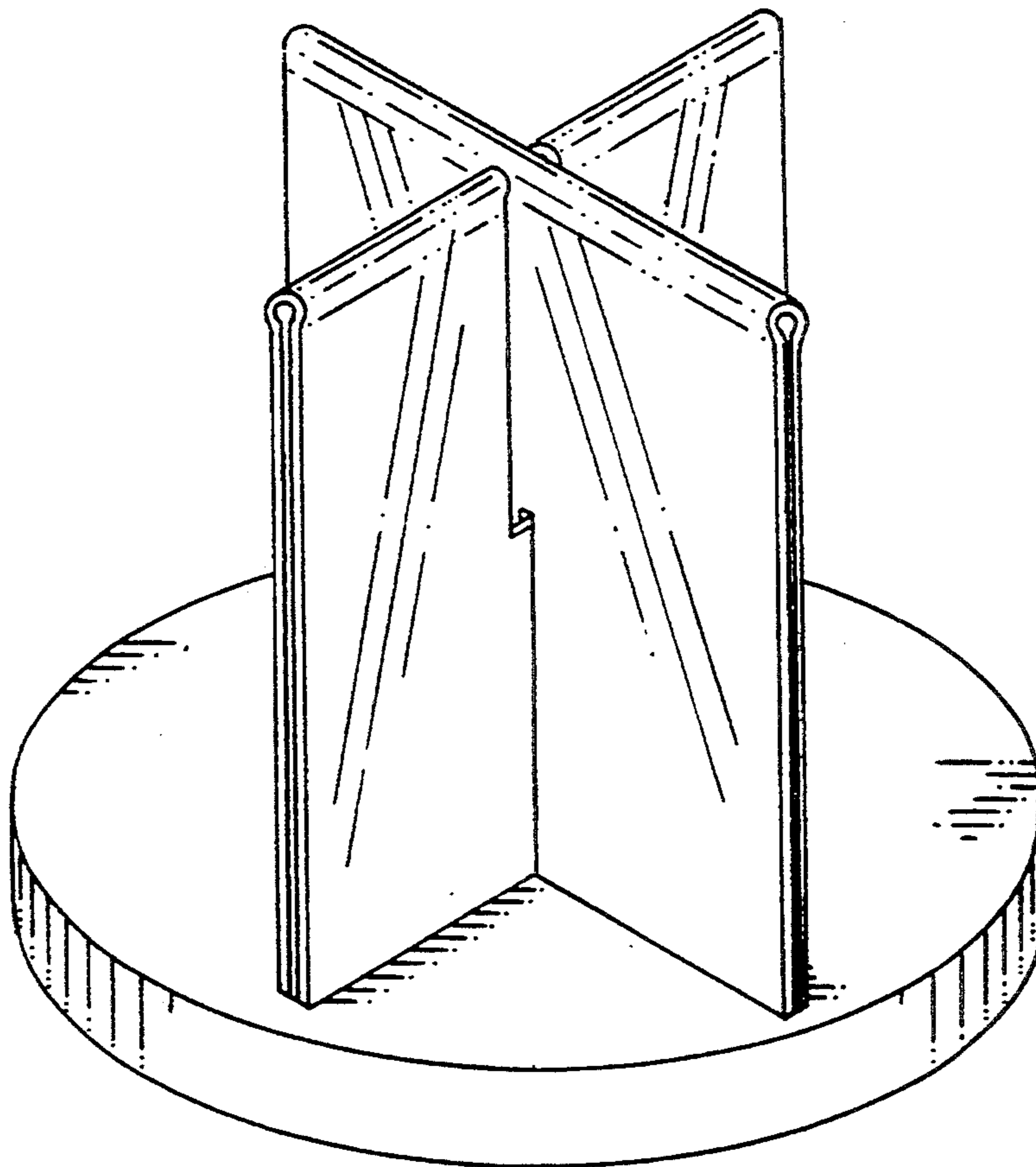

FIG. 1

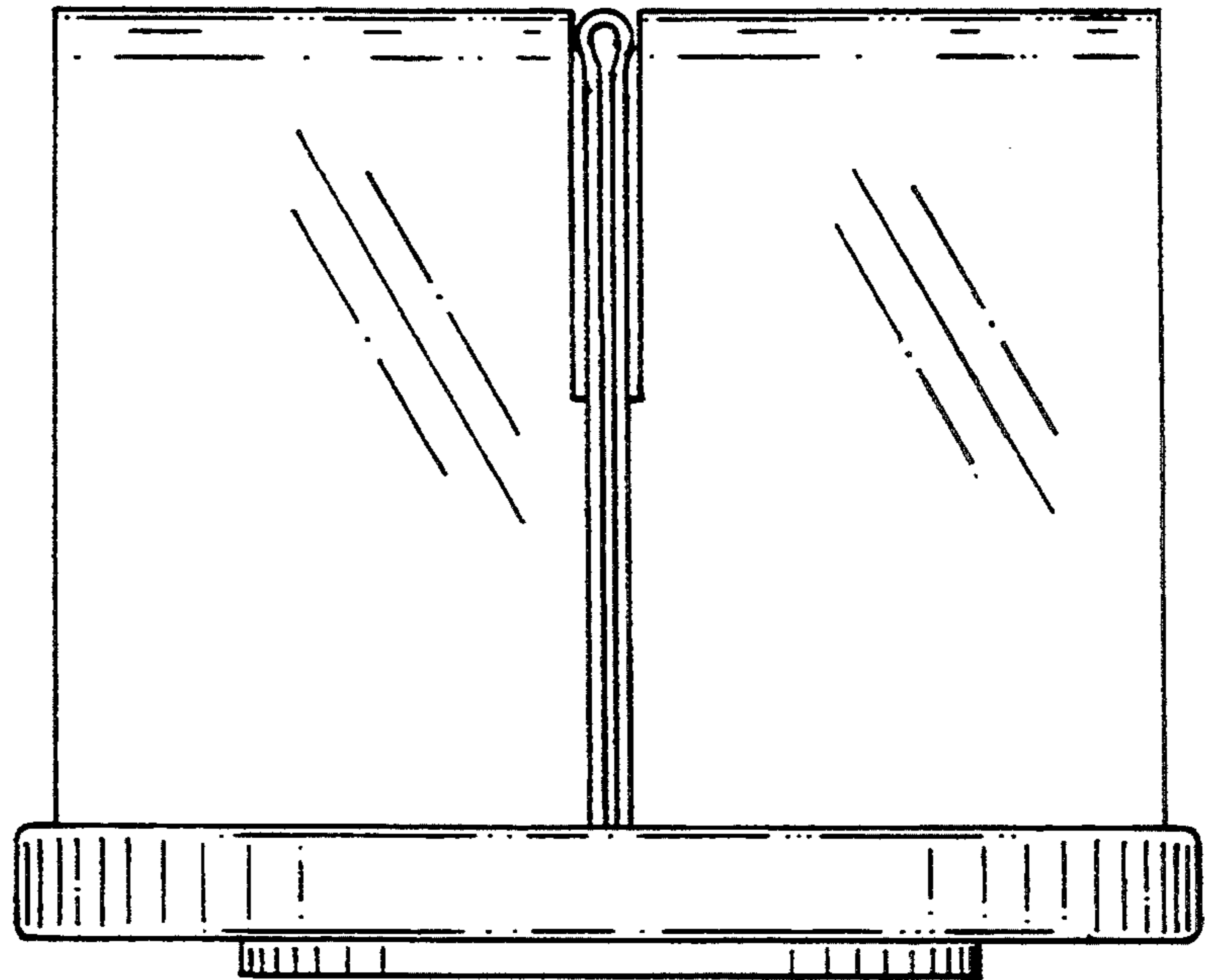

FIG. 2

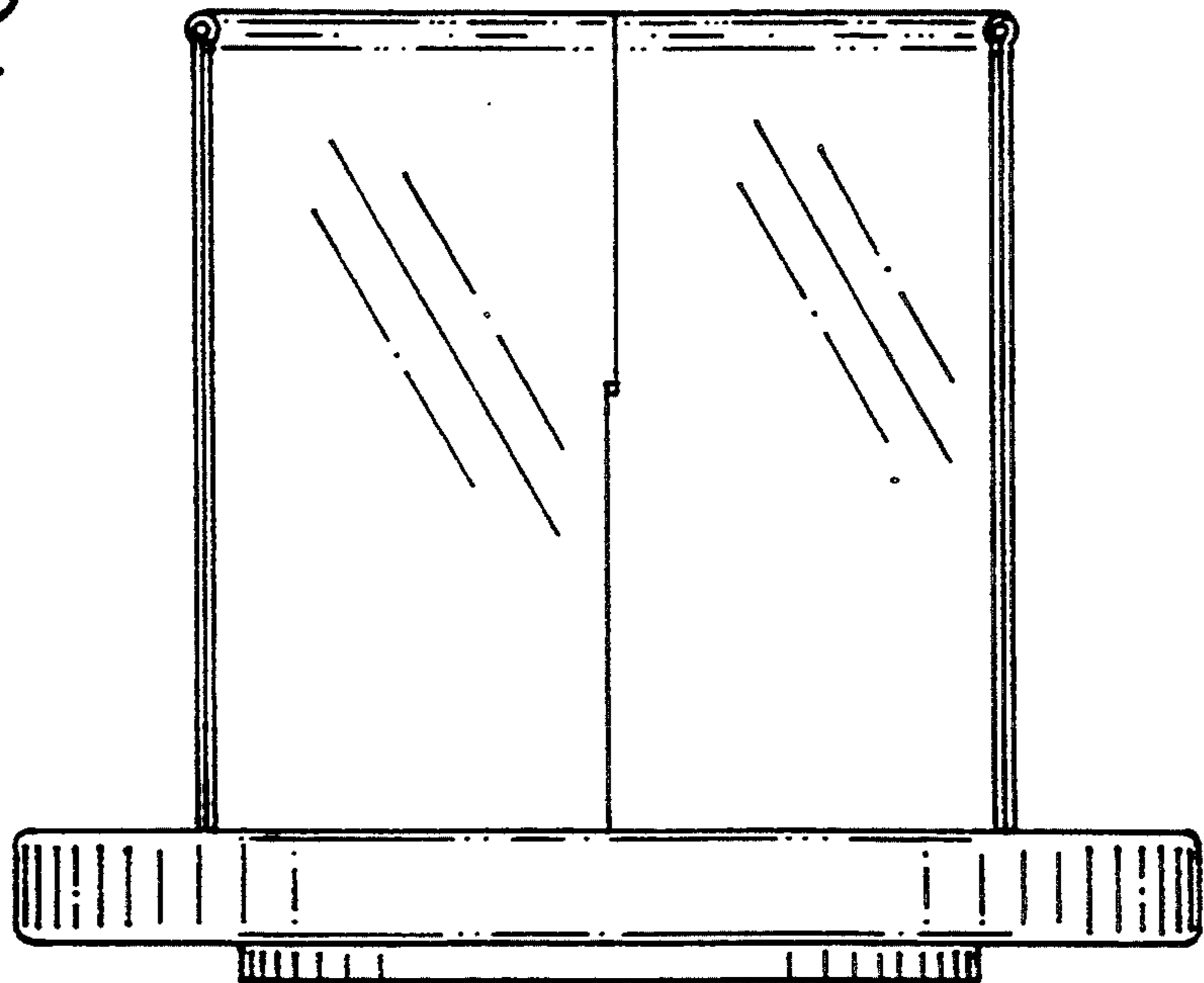

FIG. 3

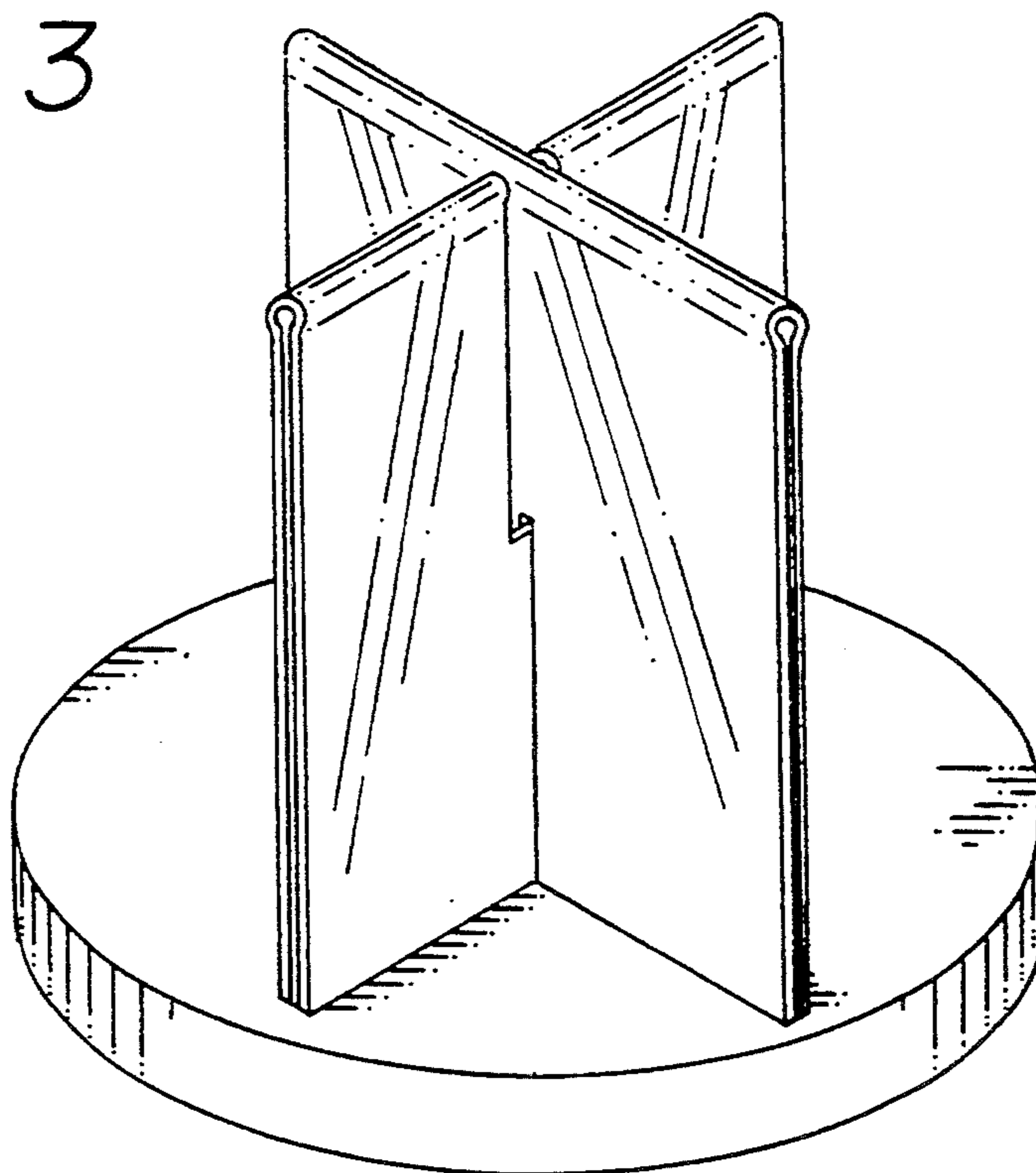

FIG. 4

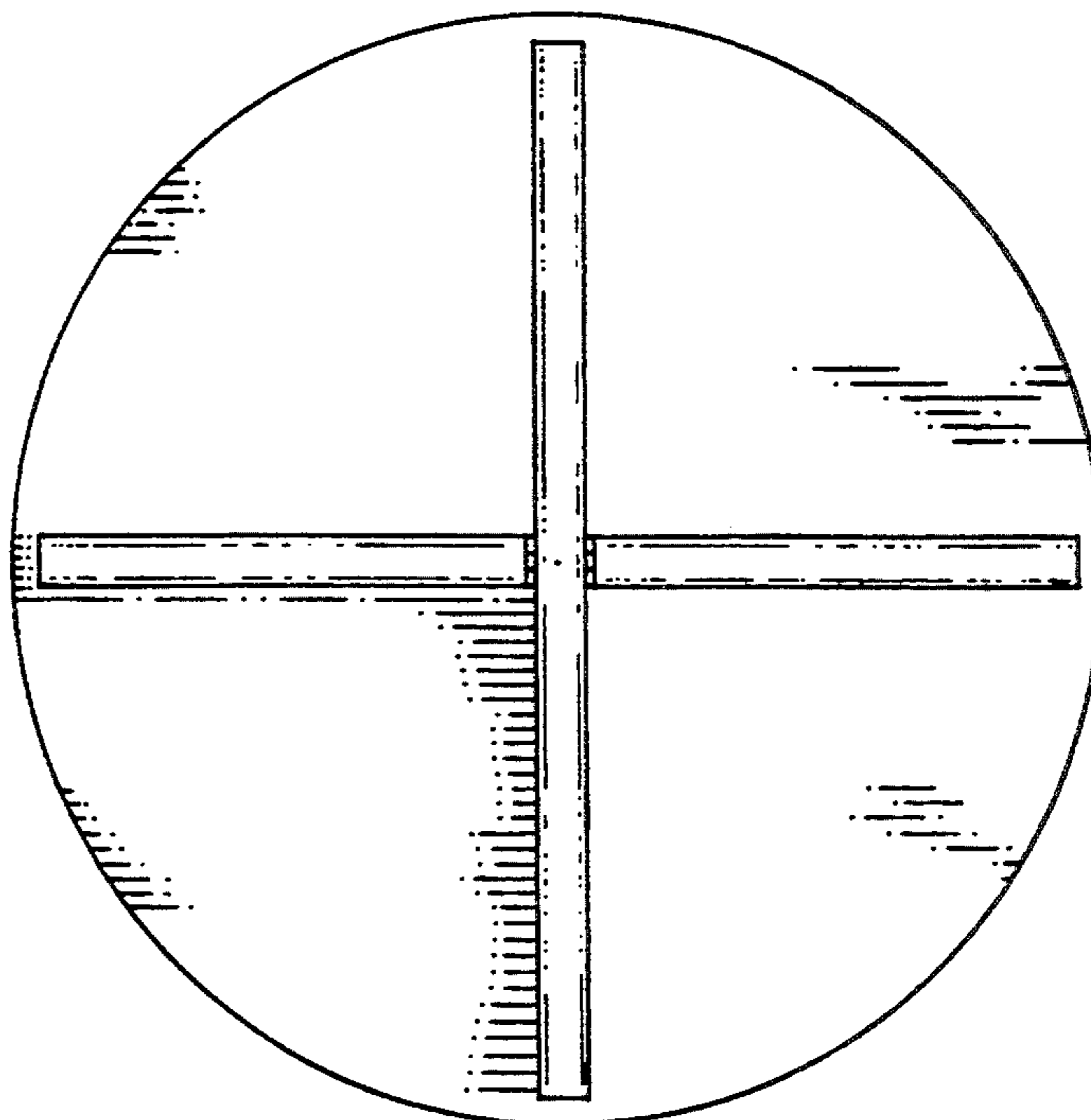

FIG. 5

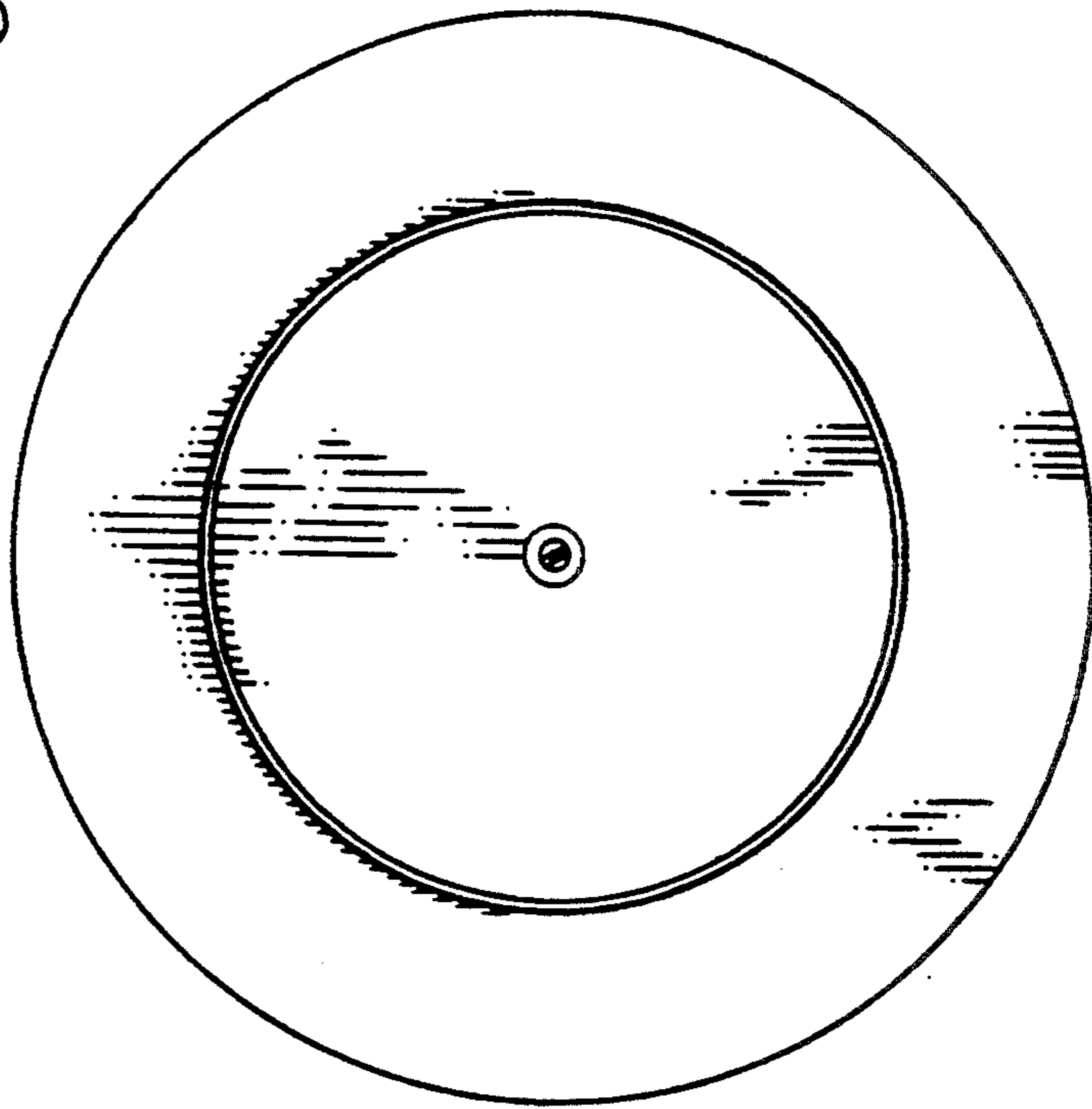

FIG. 6

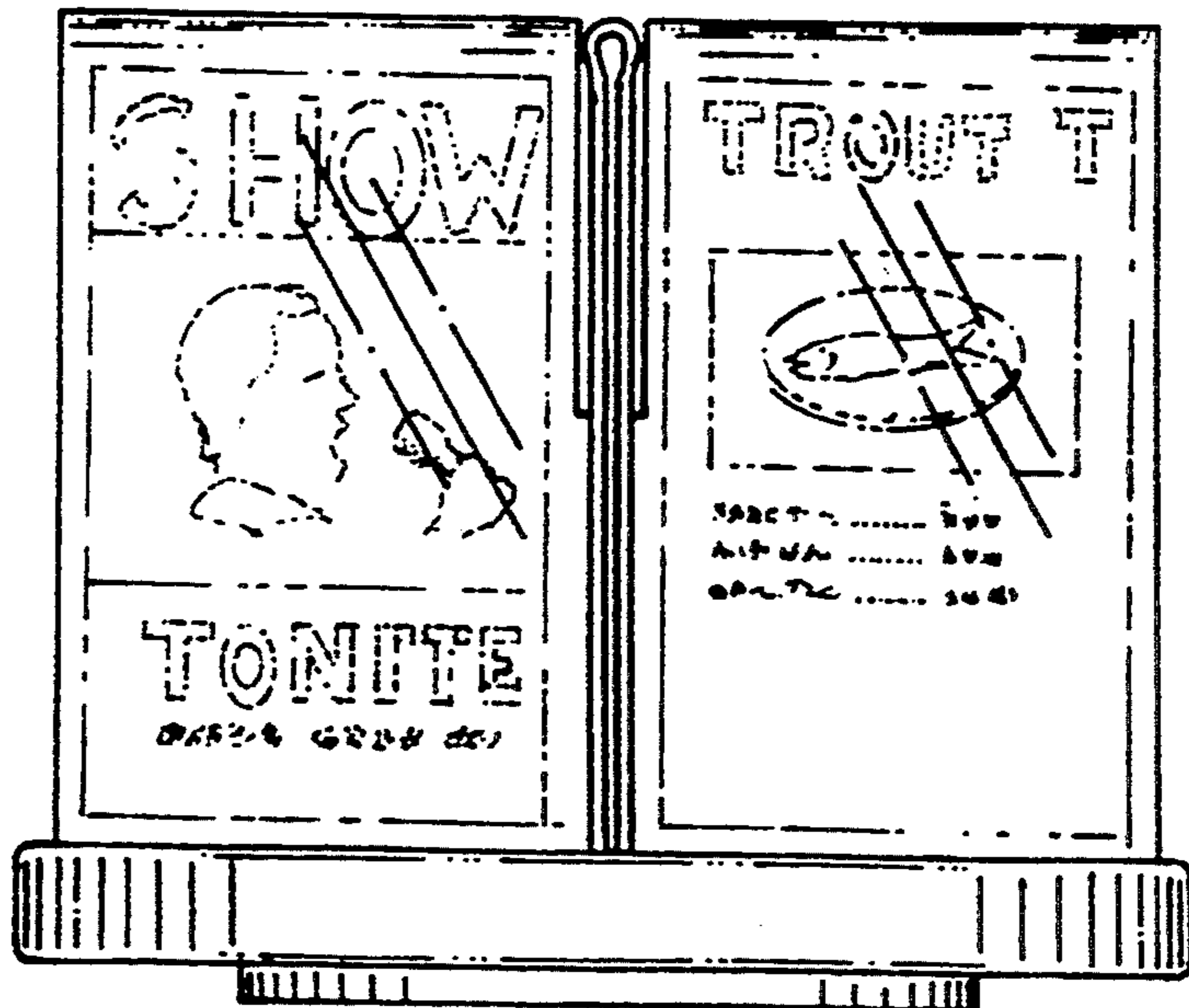

FIG. 7

