



US00D358076S

United States Patent [19]

[11] Patent Number: **Des. 358,076**

Woller et al.

[45] Date of Patent: **** May 9, 1995**

[54] **OUTBOARD MARINE ENGINE LOWER UNIT AND PROPELLER LOCK**

Attorney, Agent, or Firm—Burns, Doane, Swecker & Mathis

[75] Inventors: **Ronald R. Woller; John A. Woller, Jr.,** both of Decatur; **Harlan J. Haight,** Madison, all of Ala.

[57] **CLAIM**

The ornamental design for an outboard marine engine lower unit and propeller lock, as shown and described.

[73] Assignee: **Pinnacle Products, Inc.,** Decatur, Ala.

DESCRIPTION

[**] Term: **14 Years**

FIG. 1 is a perspective view of an outboard marine engine lower unit and propeller lock showing our new design, the broken line disclosure of a marine engine being for illustrative purposes only and forming no part of the claimed design;

[21] Appl. No.: **11,715**

FIG. 2 is a left side elevational view thereof;

[22] Filed: **Aug. 12, 1993**

FIG. 3 is a right side elevational view thereof;

[52] U.S. Cl. **D8/331**

FIG. 4 is an enlarged scale top view thereof;

[58] Field of Search **D8/330-331, D8/343; 70/14, 20, 57-58, 174**

FIG. 5 is an enlarged scale bottom view thereof;

FIG. 6 is an enlarged scale rear elevational view thereof;

[56] **References Cited**

FIG. 7 is an enlarged scale front elevational view thereof; and,

U.S. PATENT DOCUMENTS

FIG. 8 is a perspective view of a second lower unit and propeller lock which is a mirror image of FIG. 1.

4,979,381	12/1990	Luongo	70/14
5,184,488	2/1993	Sandlin	70/14

Characteristic features of the outboard marine engine lower unit and propeller lock are the two piece adjustable lock arrangement.

Primary Examiner—Brian N. Vinson

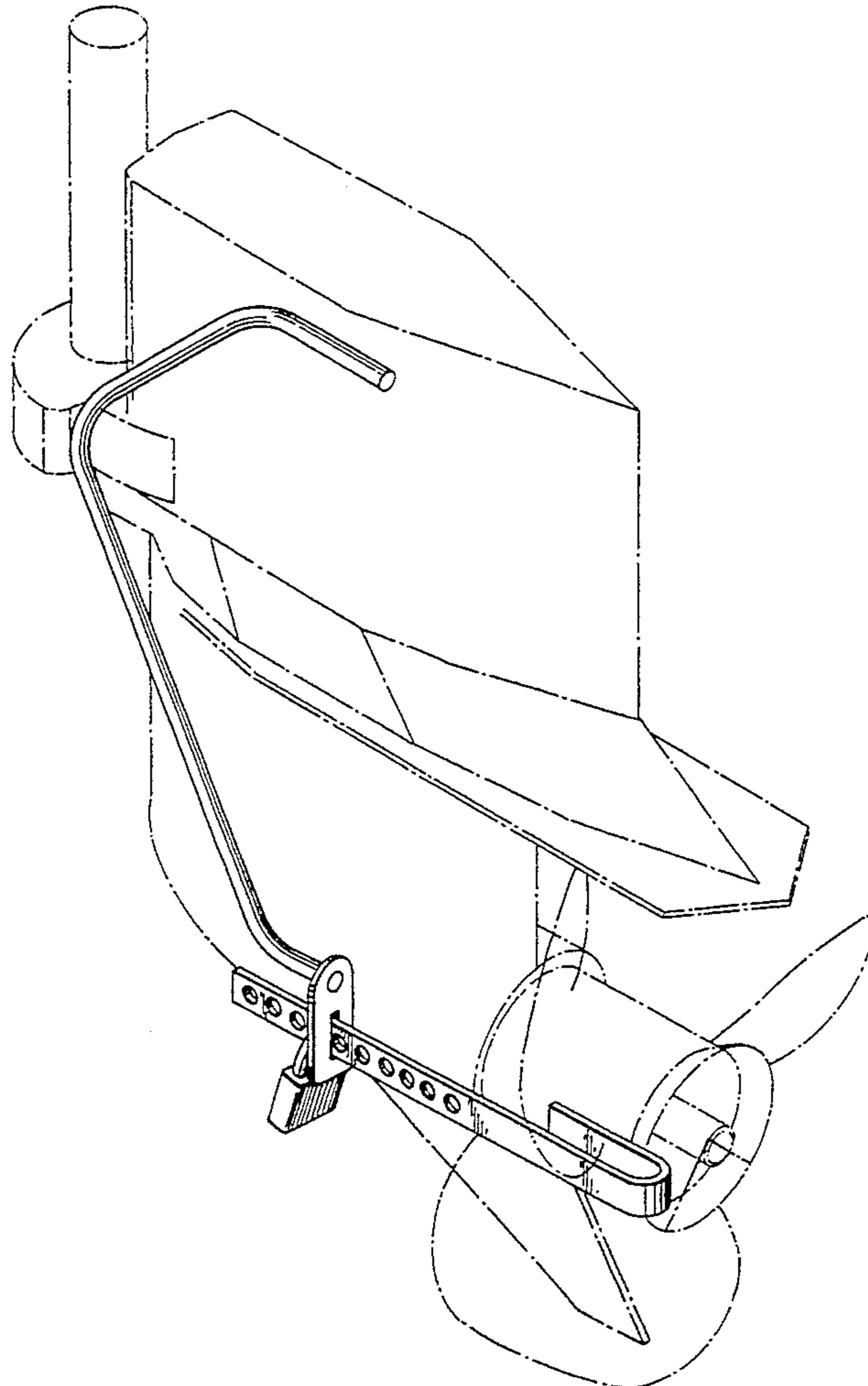

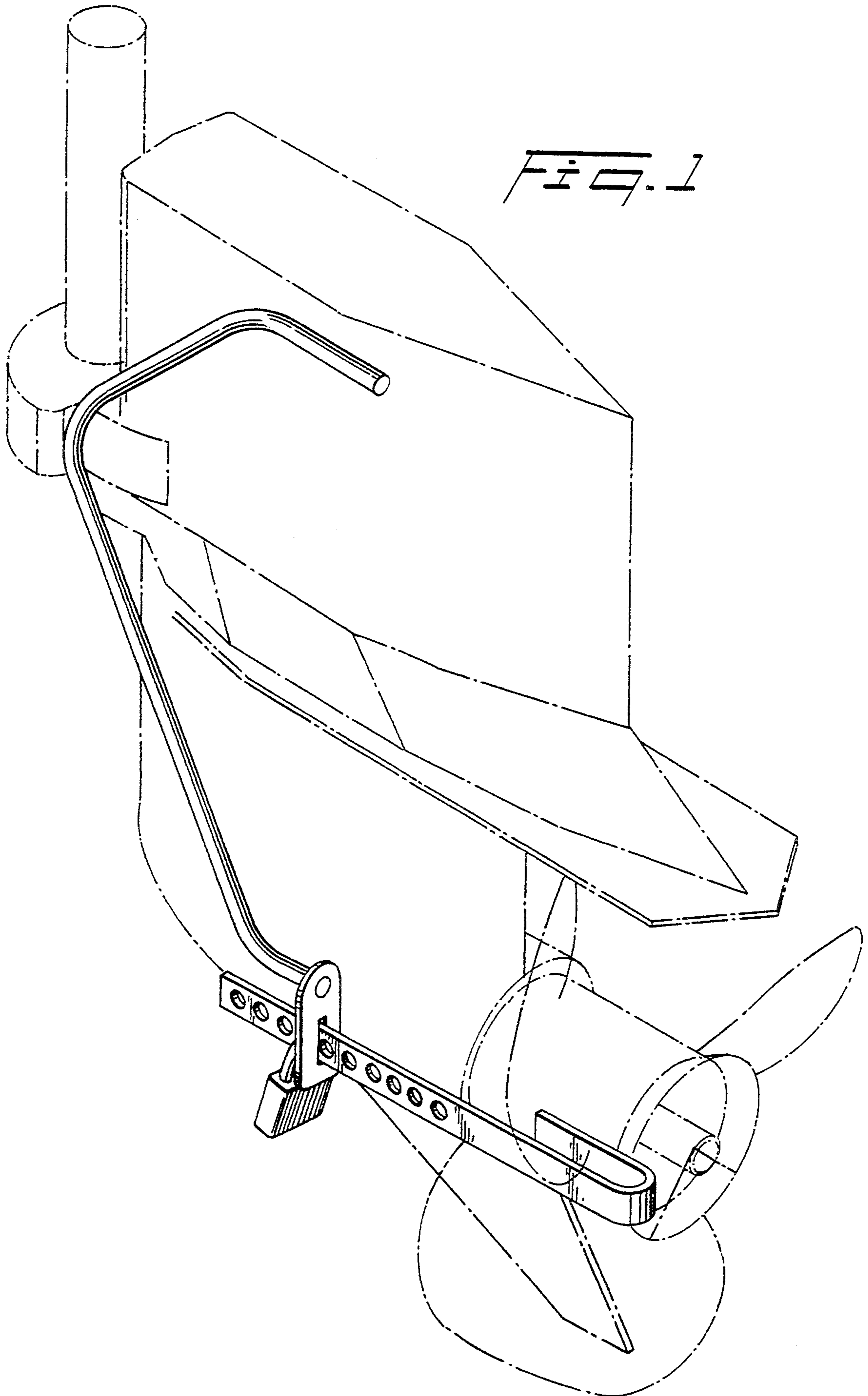

Fig. 1

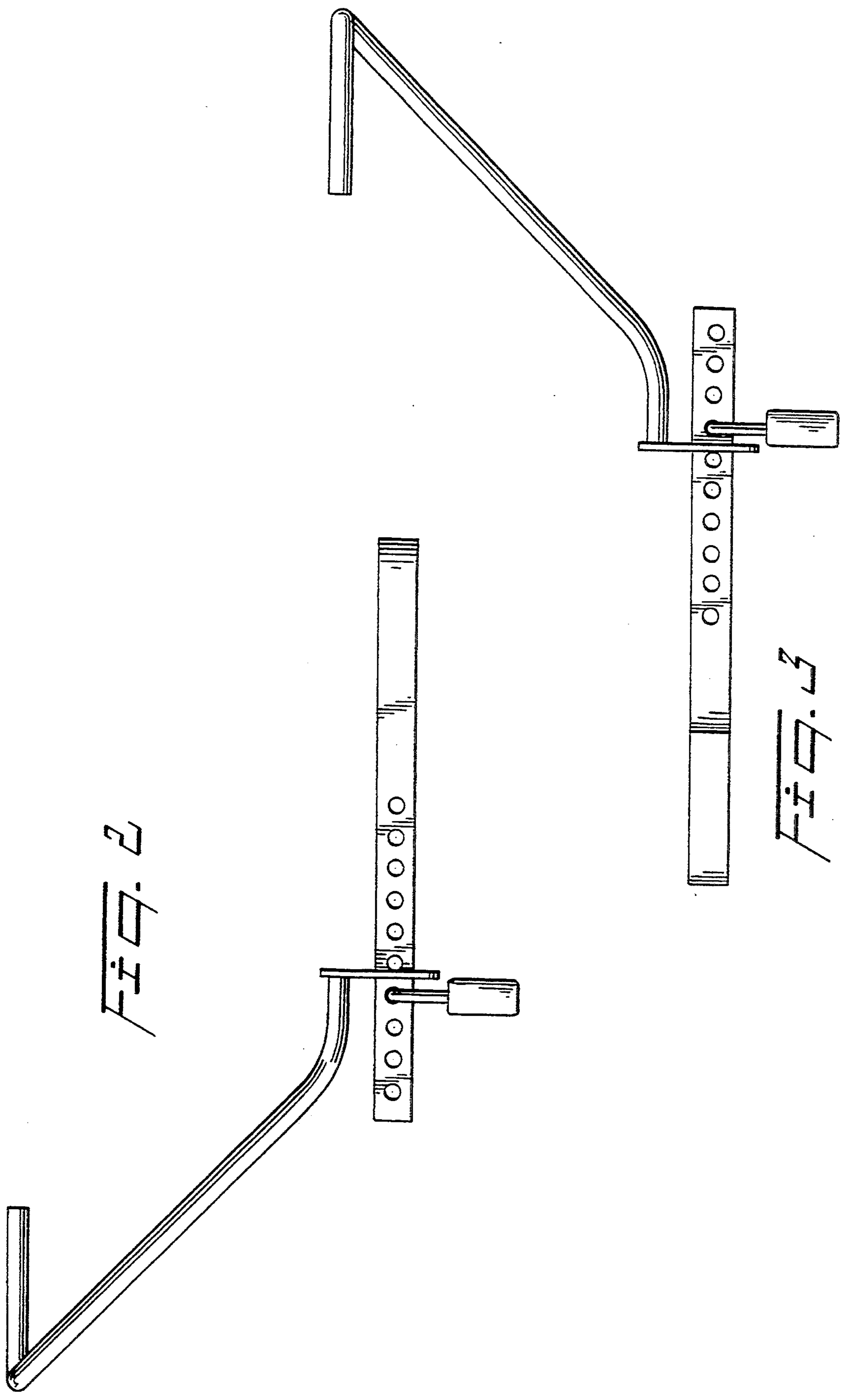

FIG. 2

FIG. 3

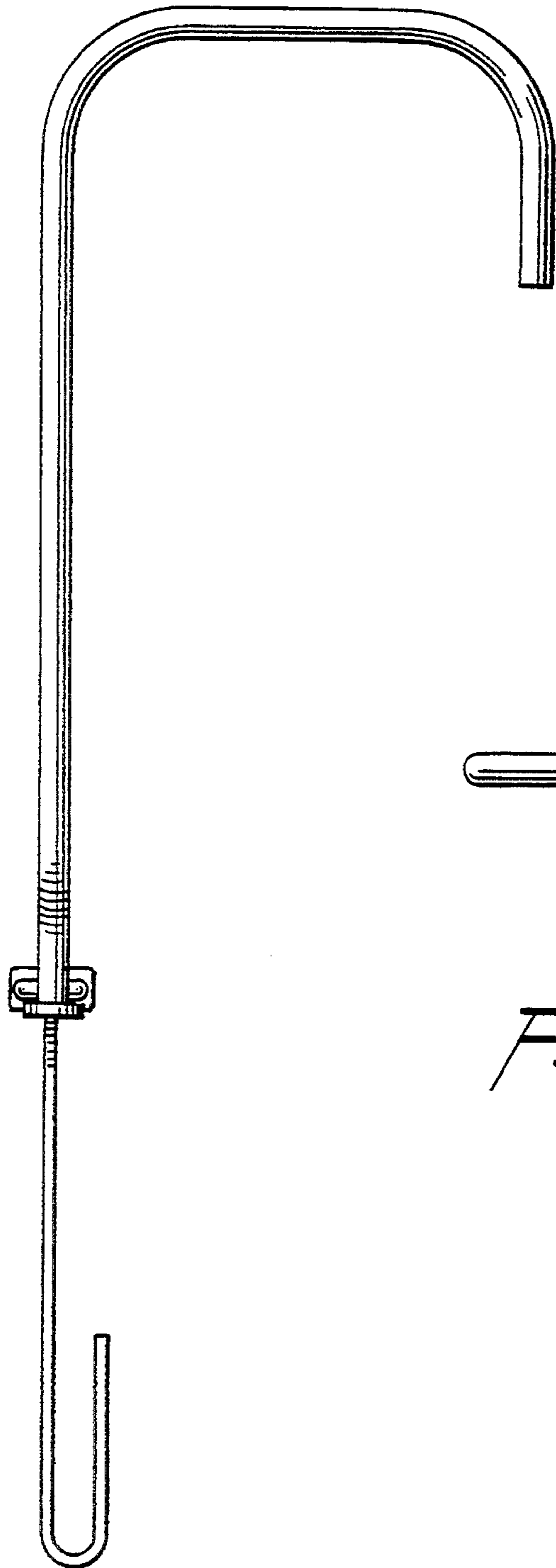

FIG. 4

FIG. 5

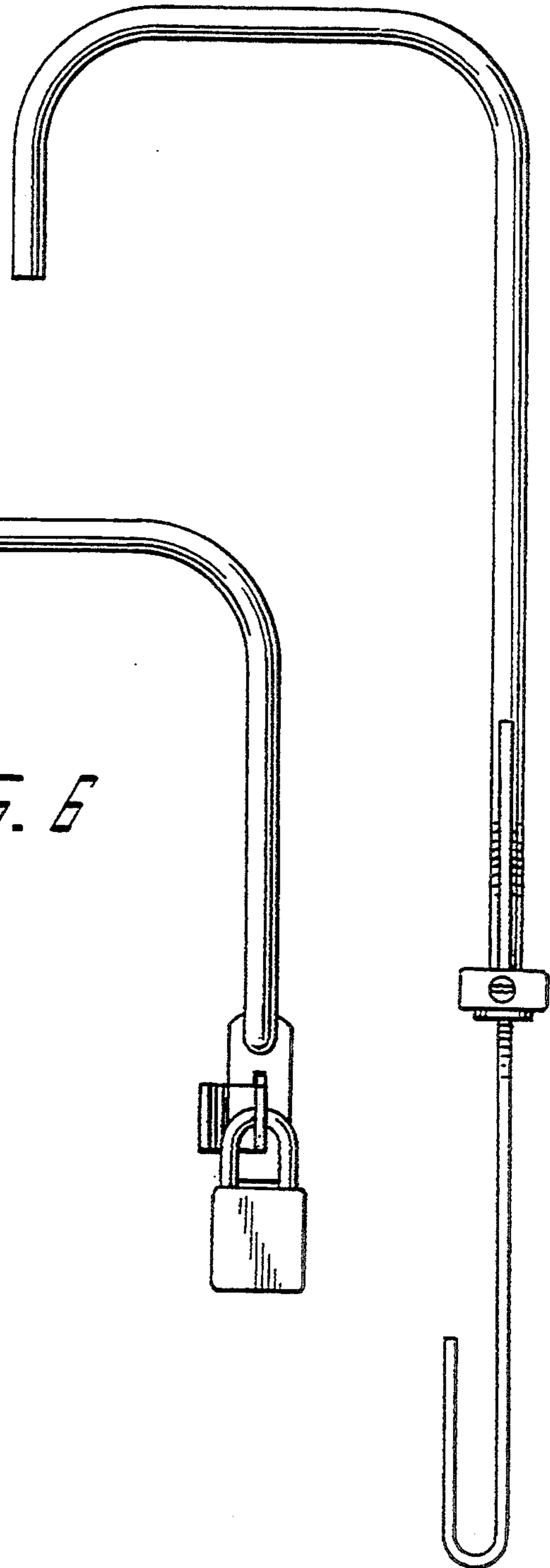

FIG. 6

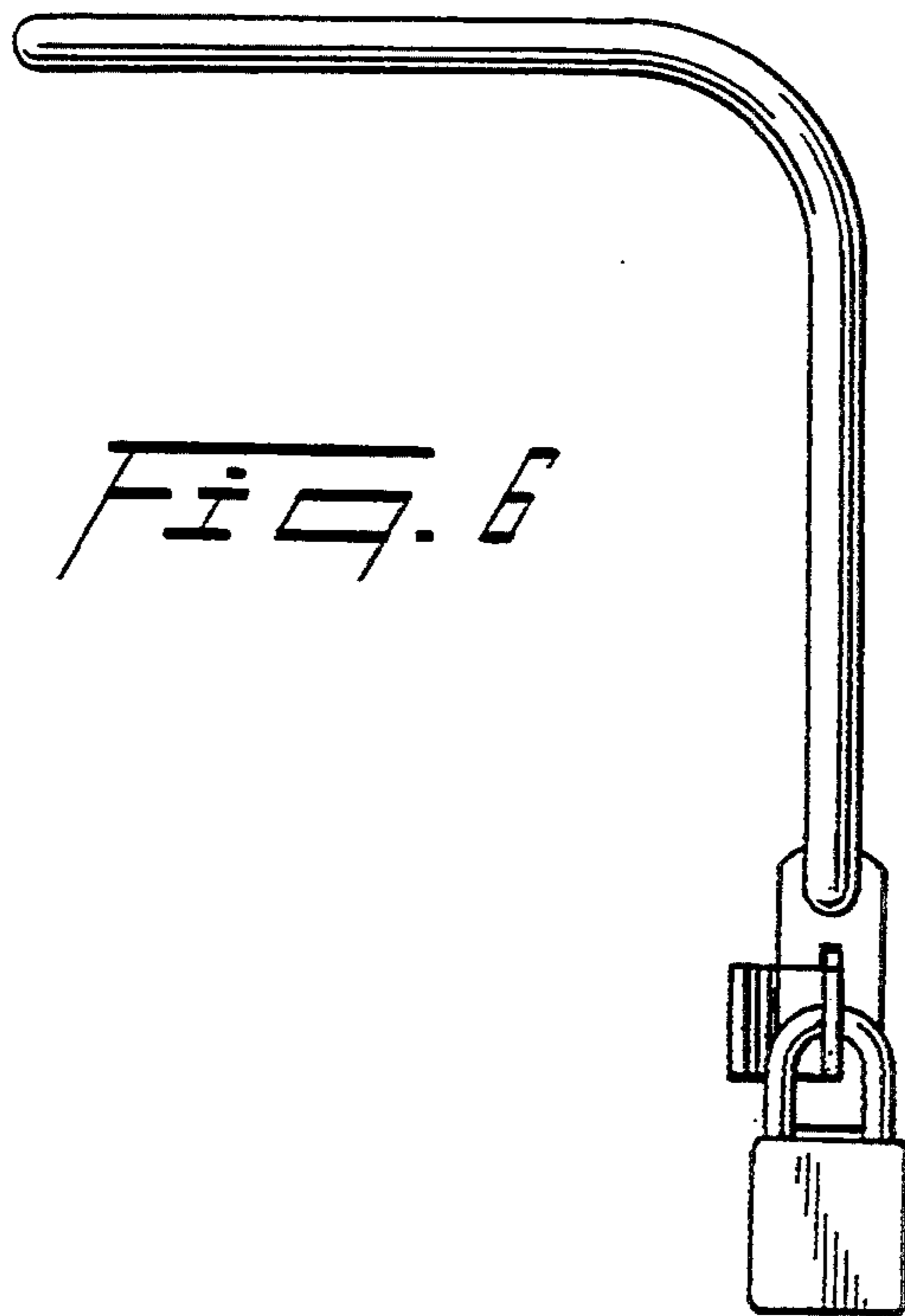

Fig. 1

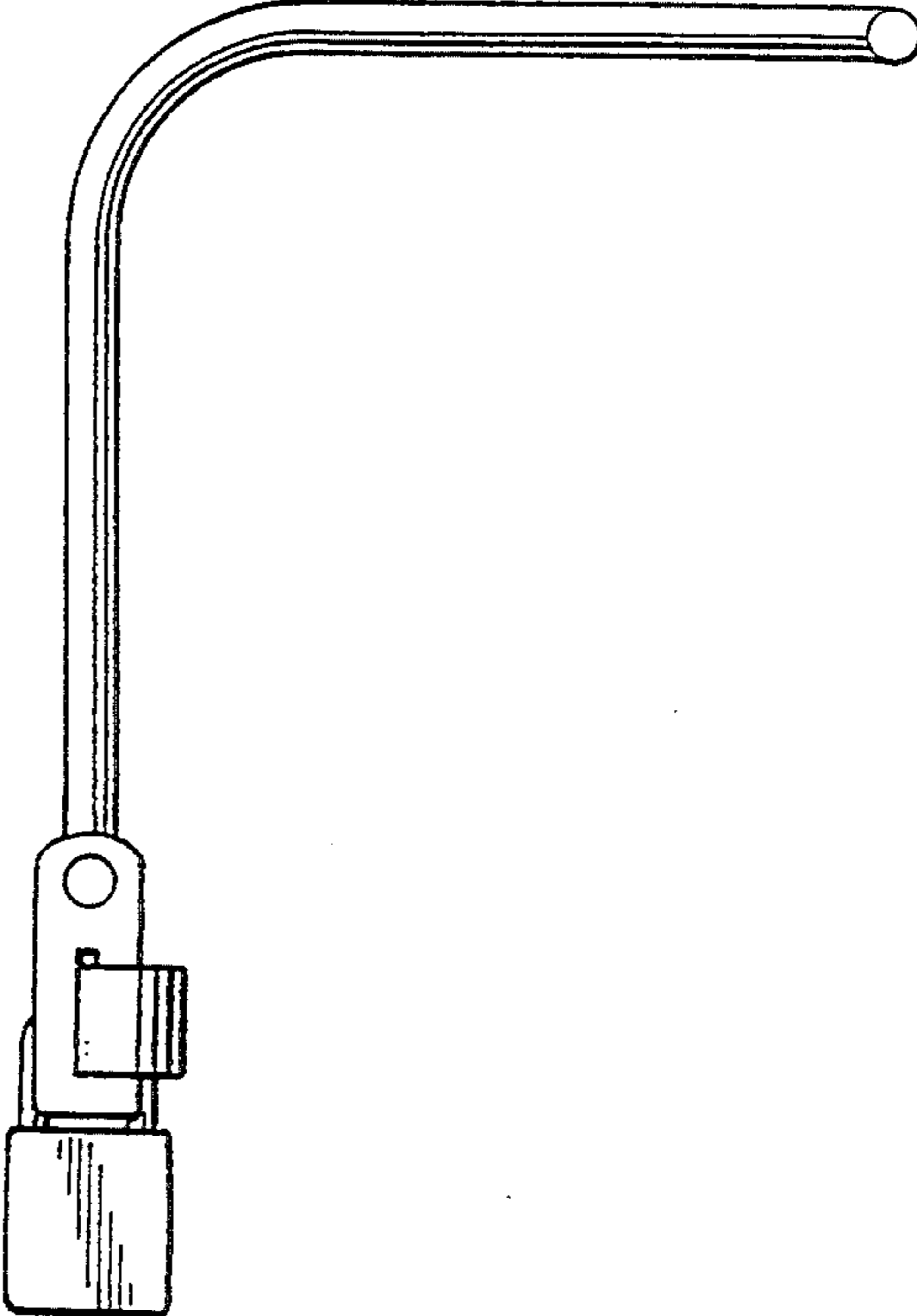

Fig. 2

