



US00D357940S

United States Patent [19] Linder

[11] Patent Number: **Des. 357,940**
[45] Date of Patent: **** May 2, 1995**

- [54] WIRE DOCUMENT STAND
- [75] Inventor: **Steven E. Linder**, Portland, Oreg.
- [73] Assignee: **Anthro Corporation**, Portland, Oreg.
- [**] Term: **14 Years**
- [21] Appl. No.: **3,787**
- [22] Filed: **Jan. 15, 1993**
- [52] U.S. Cl. **D19/91; D19/88; D19/90; D6/419**
- [58] Field of Search **D6/419, 420, 511, 566; D19/35, 36, 65, 75, 78, 86, 88, 90, 91, 99, 100; 248/441.1, 442.2, 465.1; 211/126, 181; 40/341**

FOREIGN PATENT DOCUMENTS

1518012 3/1968 France 248/441.1

OTHER PUBLICATIONS

Anthro Corporation Catalog, p. 17, 1991.
Primary Examiner—Martie Thompson
Attorney, Agent, or Firm—Stoel Rives Boley Jones & Grey

[56] **References Cited**
U.S. PATENT DOCUMENTS

D. 264,032	4/1982	Rule	D6/419 X
D. 290,970	7/1987	Rich	D6/419 X
D. 312,175	11/1990	Kelley	D19/91 X
318,253	5/1885	Holloway	248/465.1 X
815,480	3/1906	Silven	248/465.1
1,050,494	1/1913	Senders	248/465.1 X
1,581,063	4/1926	Keese	248/465.1 X
1,670,891	5/1928	Keese	248/465.1 X

[57] **CLAIM**

The design for a wire document stand, as shown and described.

DESCRIPTION

FIG. 1 is a right, rear perspective view of a wire document stand;
 FIG. 2 is a left side elevational view thereof, the support bracket and fragmentary horizontal surface being depicted by means of broken lines for illustrative purposes only and forming no part of the claimed design;
 FIG. 3 is a front elevational view thereof;
 FIG. 4 is a rear elevational view thereof;
 FIG. 5 is a top plan view thereof; and,
 FIG. 6 is a bottom plan view thereof.

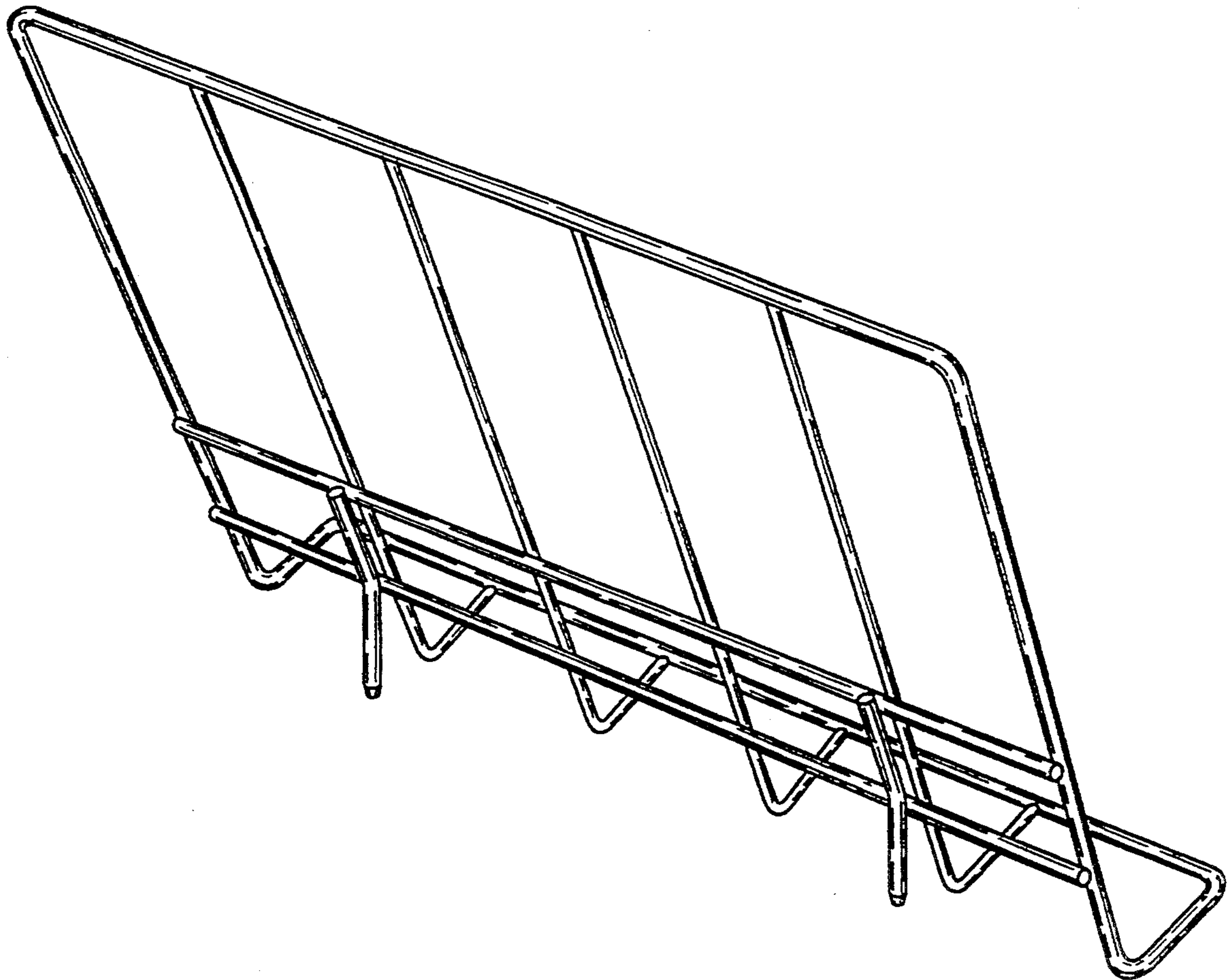

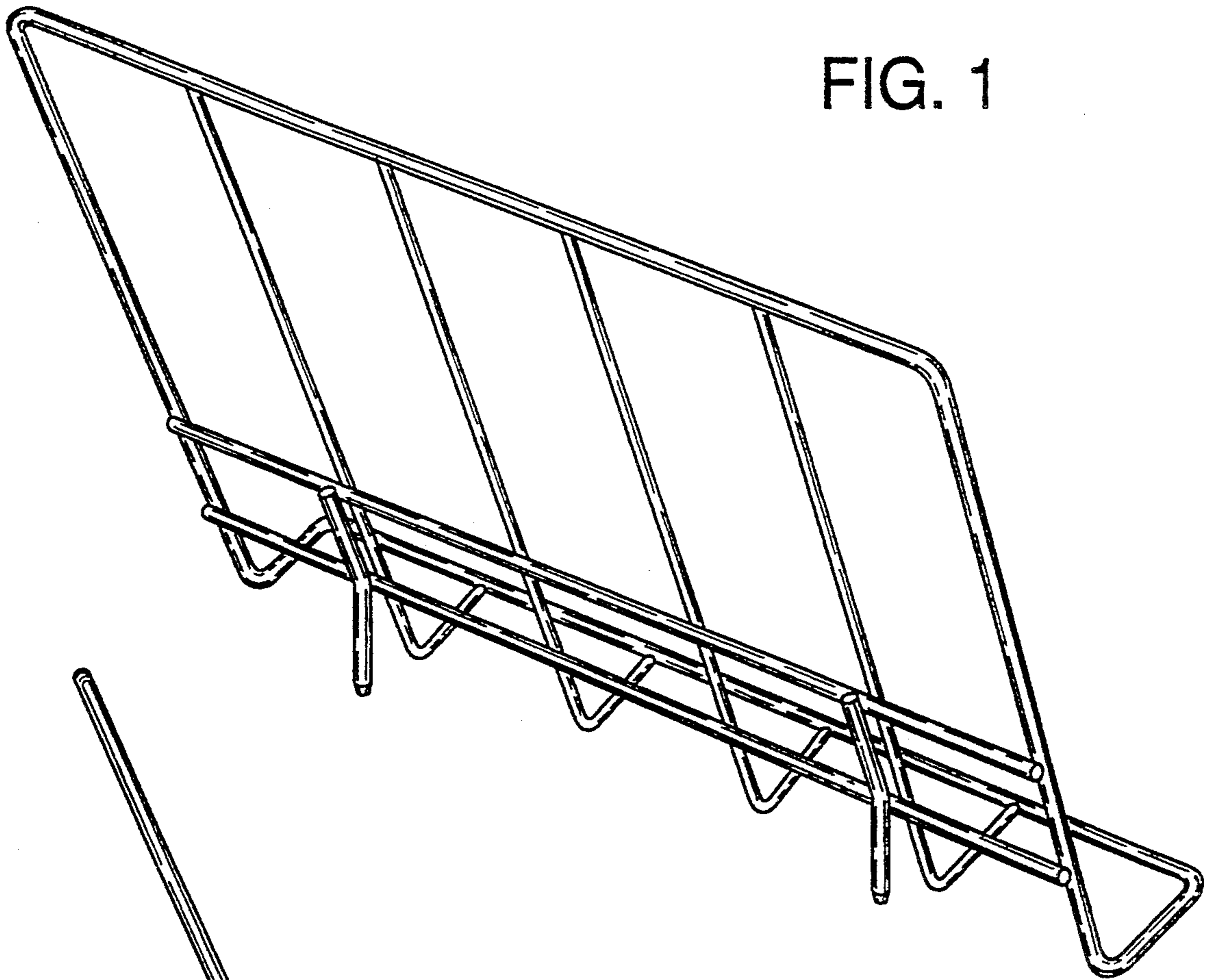

FIG. 1

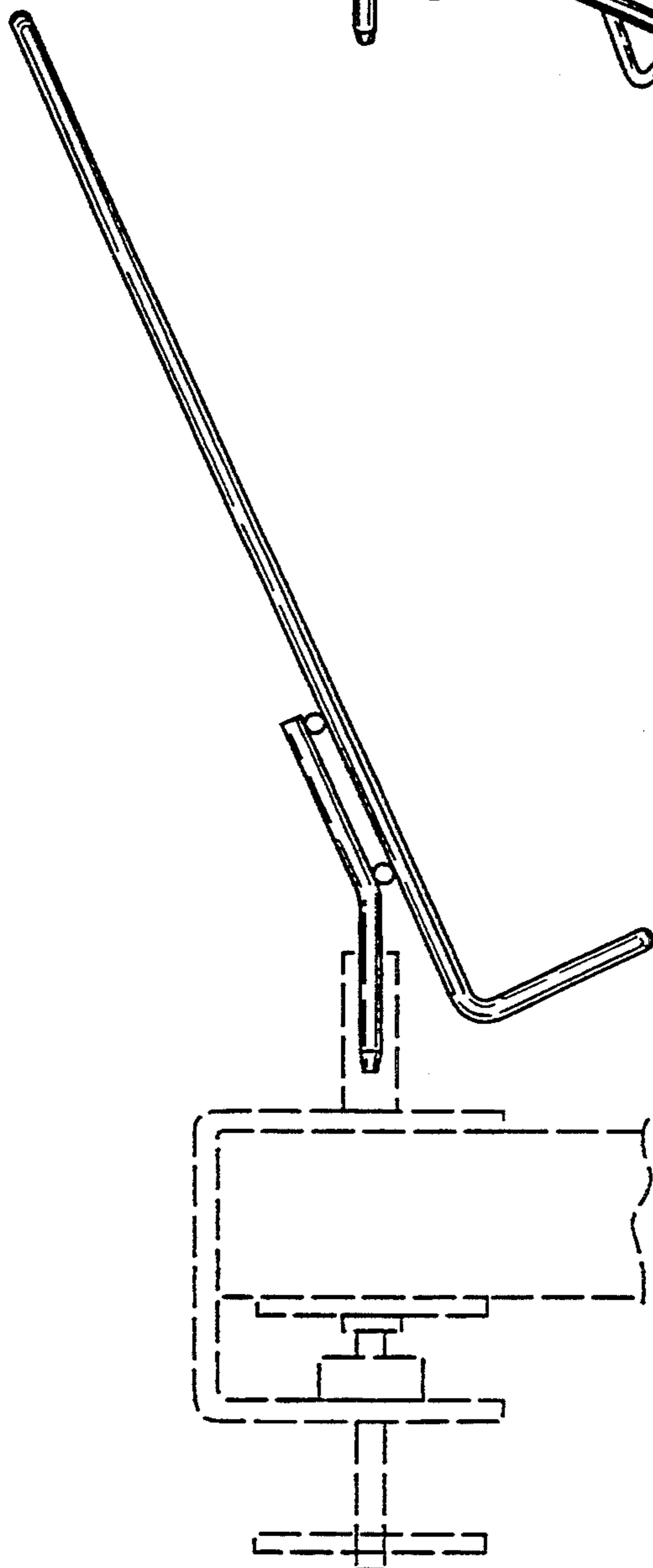

FIG. 2

FIG. 3

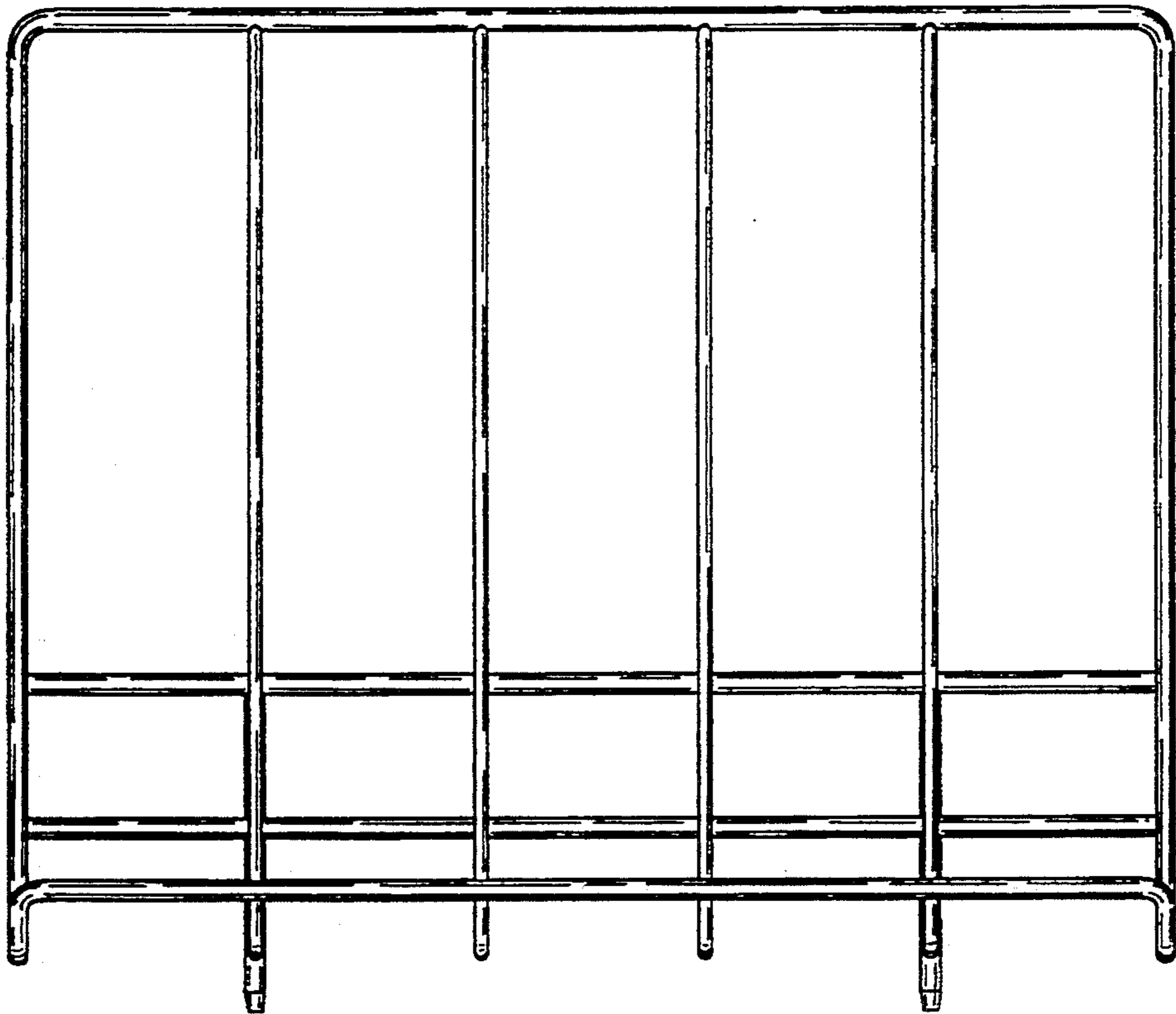

FIG. 4

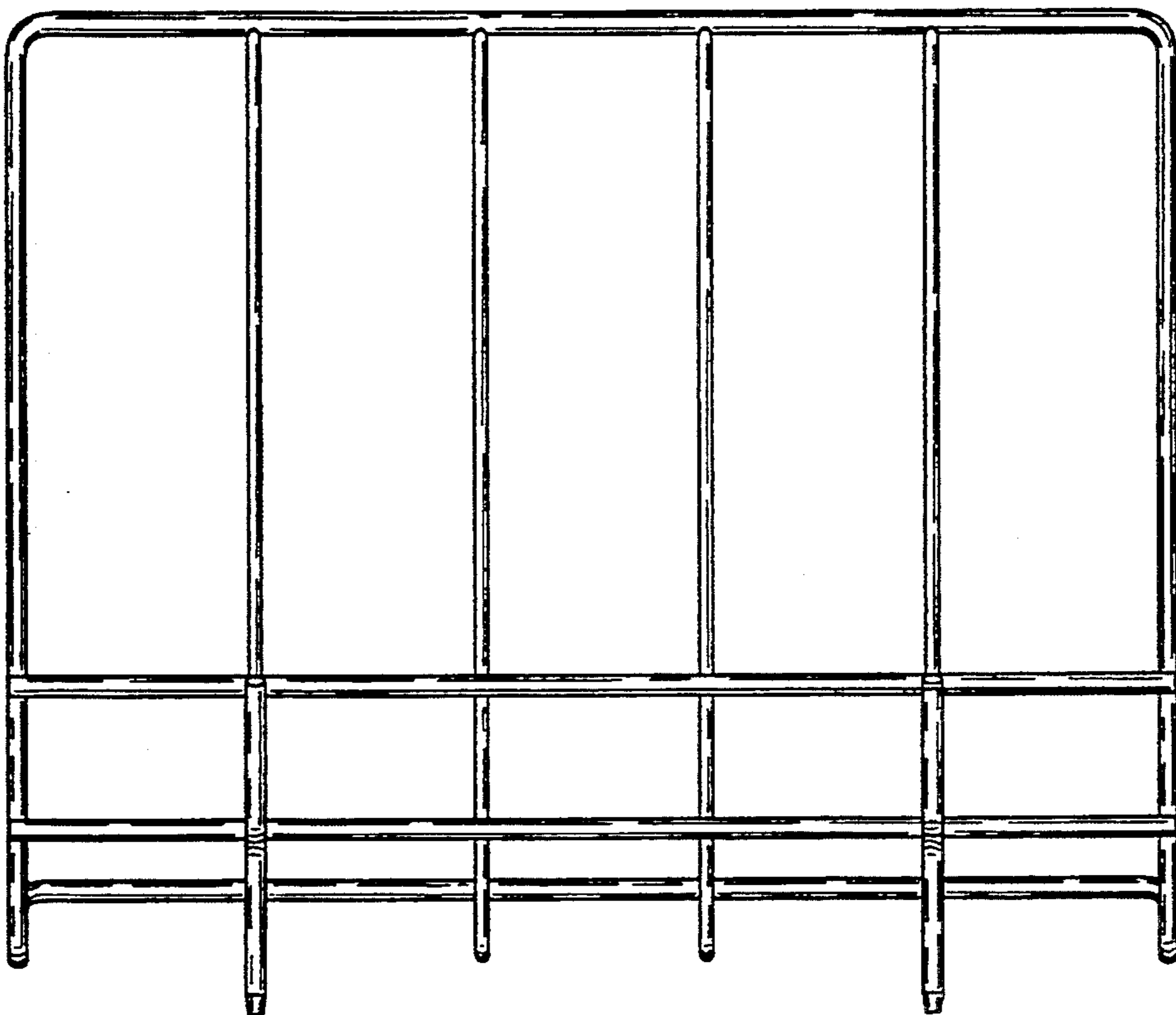

FIG. 5

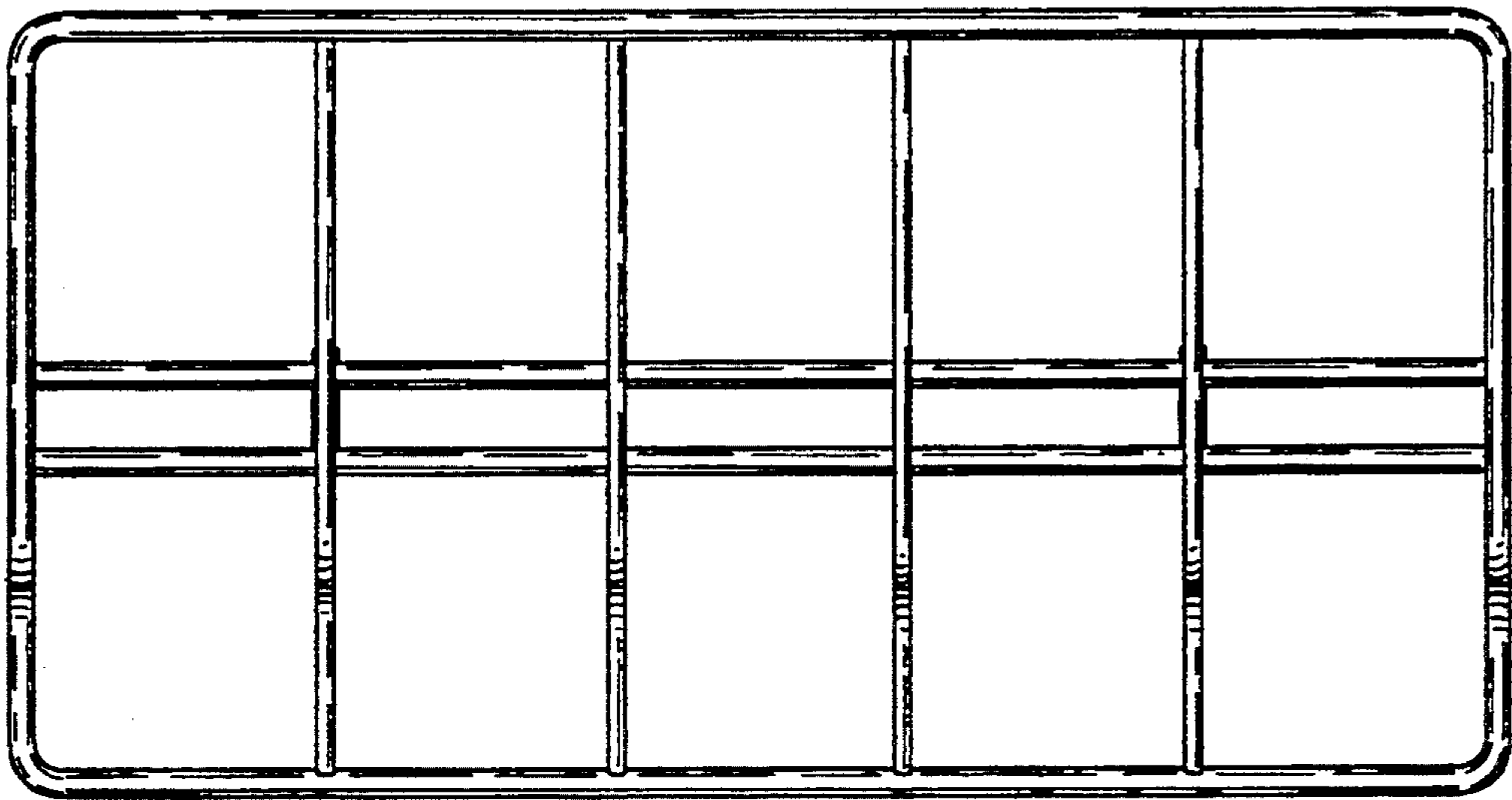

FIG. 6

