



US00D357786S

# United States Patent [19]

[11] Patent Number: **Des. 357,786**

Nichols

[45] Date of Patent: **\*\* Apr. 25, 1995**

[54] LIFT FOR AN AUTOMOBILE

3,860,216 1/1975 Brown .

[76] Inventor: **William R. Nichols**, P.O. Box 34,  
Pipestem, W. Va. 25979

4,150,813 4/1979 Mena .

4,834,339 5/1989 Clarke ..... 254/93 R

[\*\*] Term: **14 Years**

*Primary Examiner*—James M. Gandy  
*Assistant Examiner*—Robin V. Taylor  
*Attorney, Agent, or Firm*—Terry M. Gernstein

[21] Appl. No.: **17,929**

[57] **CLAIM**

[22] Filed: **Jan. 26, 1994**

The ornamental design for a lift for an automobile, as shown and described.

[52] U.S. Cl. .... **D34/31**

[58] Field of Search ..... **D34/28, 31, 33;**  
**D12/101, 106; 254/2 R, 8 R, 84, 93 R, 93 H, 93**  
**VA, 11, 133, 134, 418, 419**

**DESCRIPTION**

[56] **References Cited**

**U.S. PATENT DOCUMENTS**

- D. 204,944 5/1966 Bair ..... D34/31
- D. 345,844 4/1994 Steele ..... D34/31
- 3,064,994 2/1959 Limmer .
- 3,370,421 2/1968 Piper ..... 254/93 R

FIG. 1 is a front, top and side perspective view of the lift for an automobile showing my new design; FIG. 2 is a front elevational view thereof, the rear being a mirror image of the front shown in FIG. 2; FIG. 3 is a side elevational view thereof; FIG. 4 is an opposite side elevational view thereof; FIG. 5 is a top plan view thereof; and, FIG. 6 is a bottom plan view thereof.

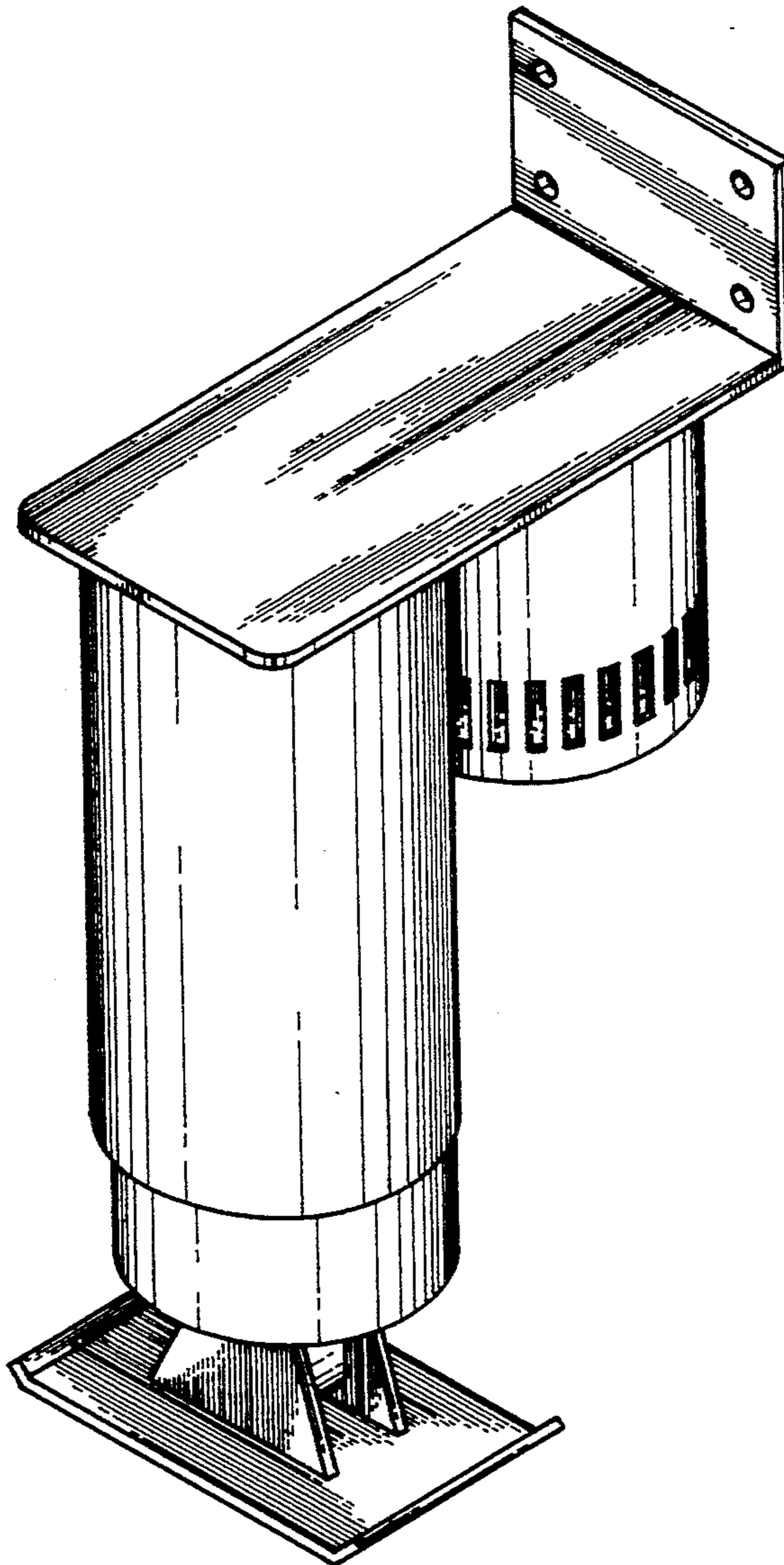

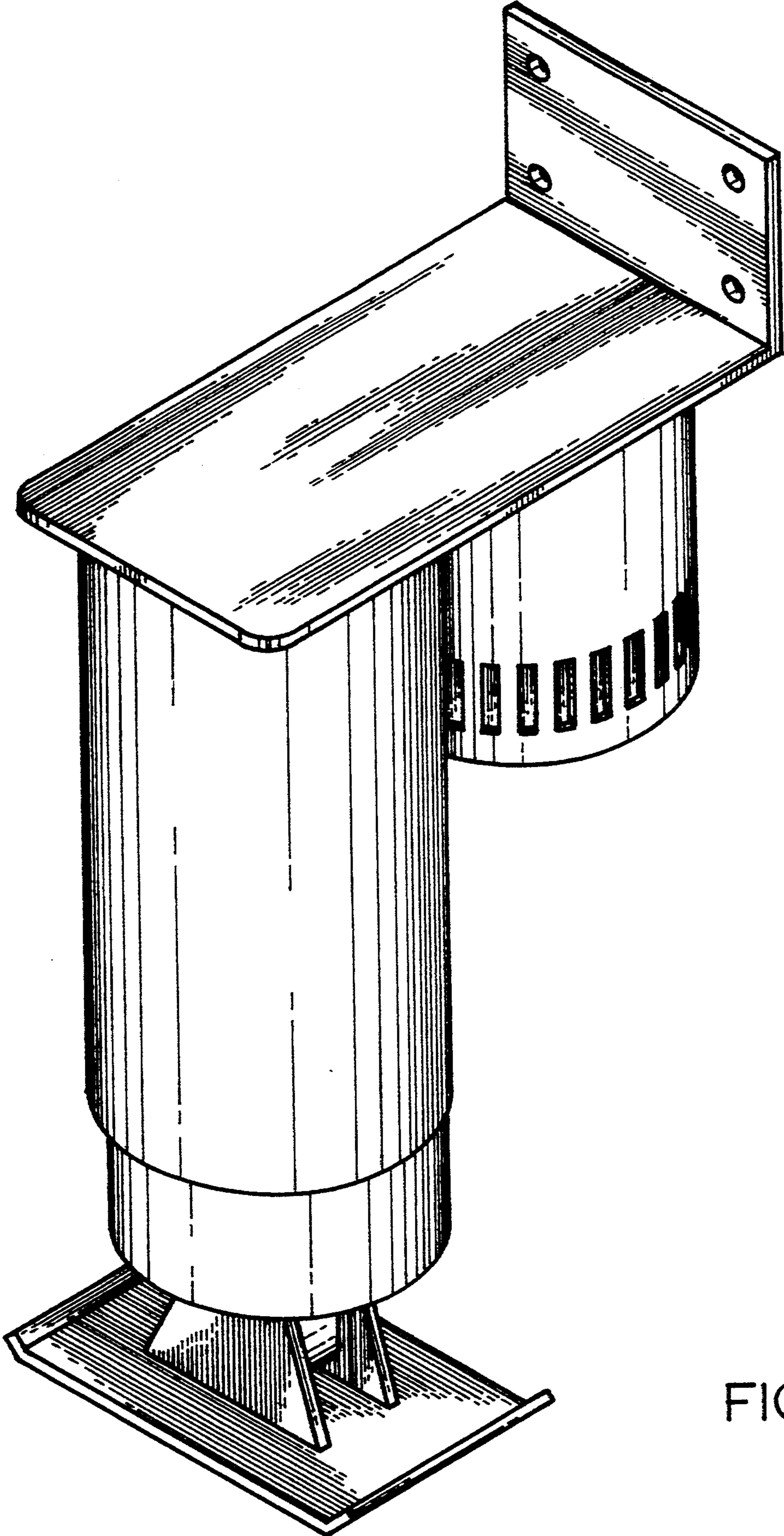

FIG.1

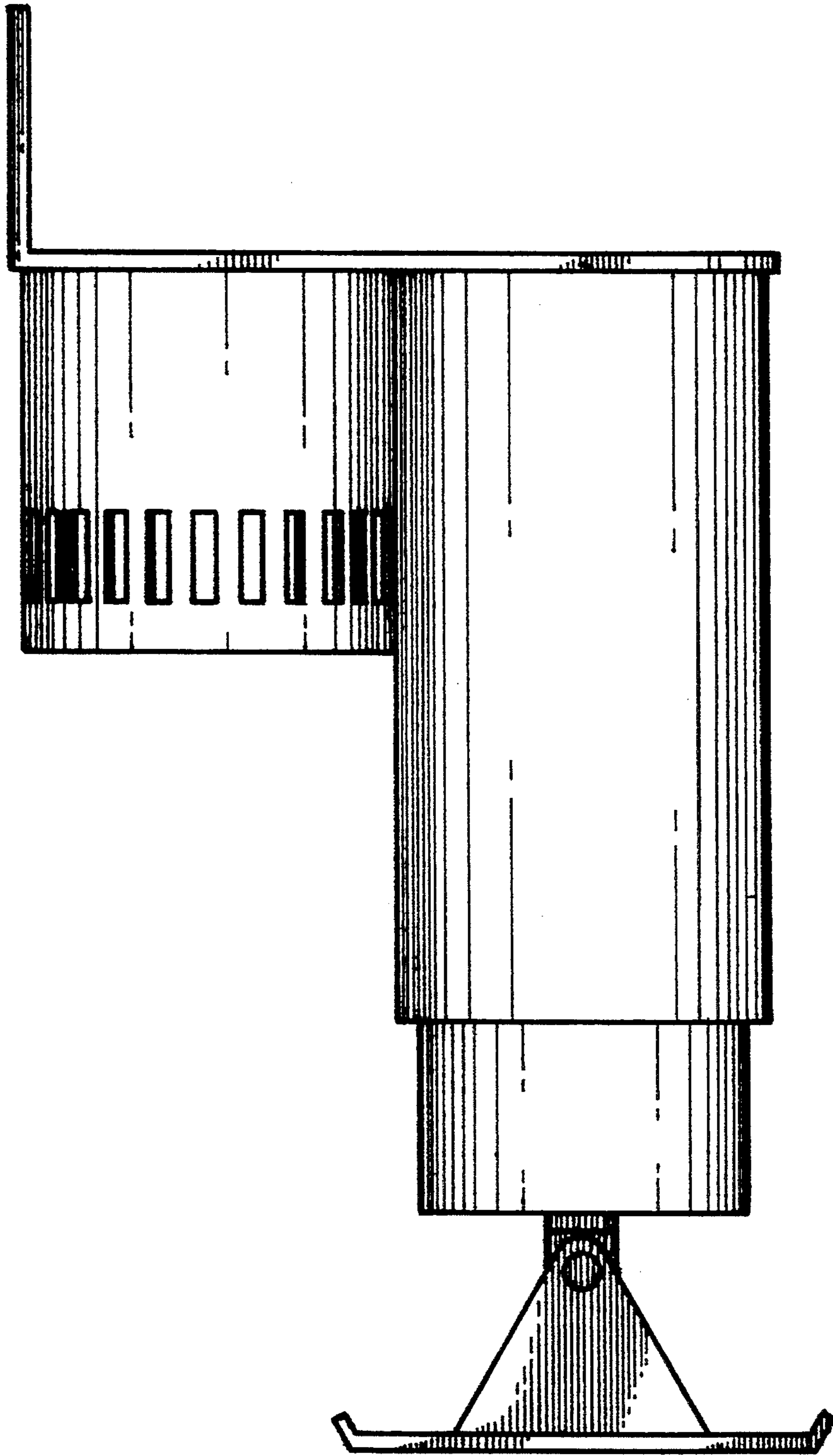

FIG. 2



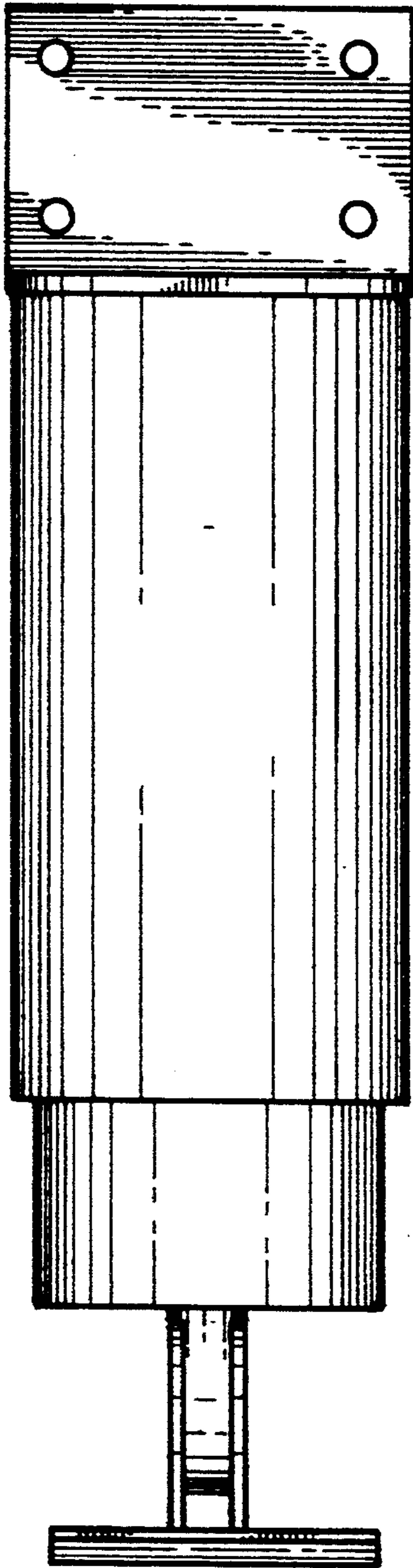

FIG. 3

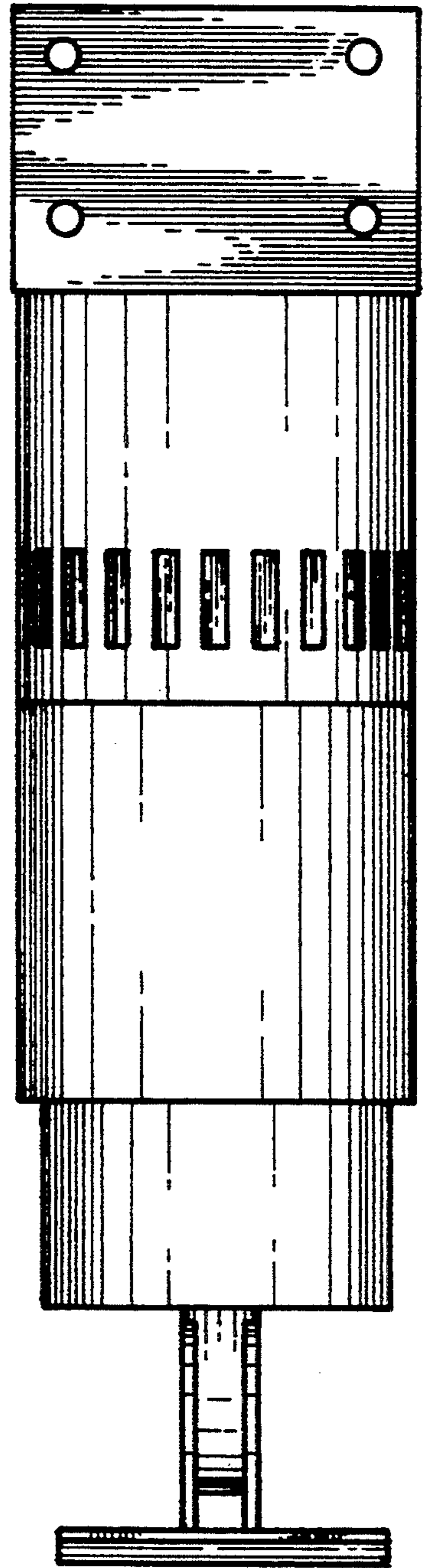

FIG. 4

FIG. 5

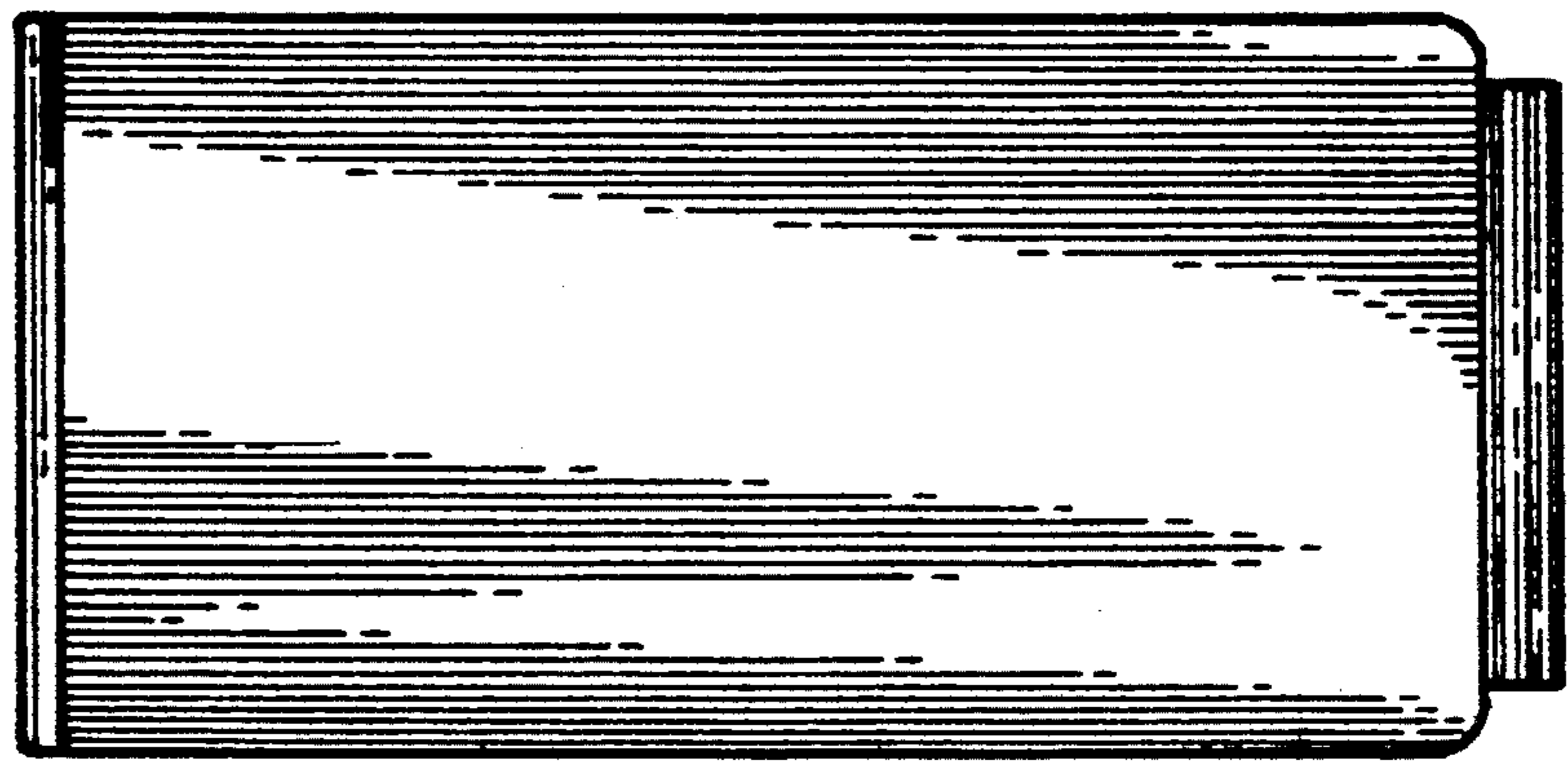

FIG. 6

