



US00D357692S

United States Patent [19]

[11] Patent Number: **Des. 357,692**

Ishikawa et al.

[45] Date of Patent: **** Apr. 25, 1995**

[54] **CUTTER INSERT**

[75] Inventors: **Youichi Ishikawa; Osamu Ichinoseki,**
both of Ibaraki, Japan

[73] Assignee: **Mitsubishi Materials Corporation,**
Tokyo, Japan

[**] Term: **14 Years**

[21] Appl. No.: **869,148**

[22] Filed: **Apr. 14, 1992**

[52] U.S. Cl. **D15/139**

[58] Field of Search **D15/138, 139;**
407/110-117

[56] **References Cited**

U.S. PATENT DOCUMENTS

- D. 324,690 5/1992 Takahashi et al. D15/139
- 4,808,045 2/1989 Tsujimura et al. 408/204
- 5,199,827 4/1993 Pantzar D15/139 X

OTHER PUBLICATIONS

Mitsubishi Carbide Turning System, S Type Boring
Bars p. 48.
Tool Engineer, distributed on Nov. 6, 1990.

Mitsubishi Metal Corporation, "Mitsubishi Carbide
Turning System", CE002, 7.89.N(8B).

Primary Examiner—Alan P. Douglas
Assistant Examiner—Antoine D. Davis
Attorney, Agent, or Firm—Cushman, Darby & Cushman

[57] **CLAIM**

The ornamental design for a cutter insert, as shown and
described.

DESCRIPTION

FIG. 1 is a perspective view of a cutter insert showing
our new design;
FIG. 2 is a front elevation view thereof;
FIG. 3 is a rear elevation view thereof;
FIG. 4 is a right side elevation view thereof;
FIG. 5 is a left side elevation view thereof;
FIG. 6 is a top plan view thereof;
FIG. 7 is a bottom view thereof;
FIG. 8 is a cross-sectional view taken along line 8—8 in
FIG. 2;
FIG. 9 is a cross-sectional view taken along line 9—9 in
FIG. 2; and,
FIG. 10 is a cross-sectional view taken along line
10—10 in FIG. 2.

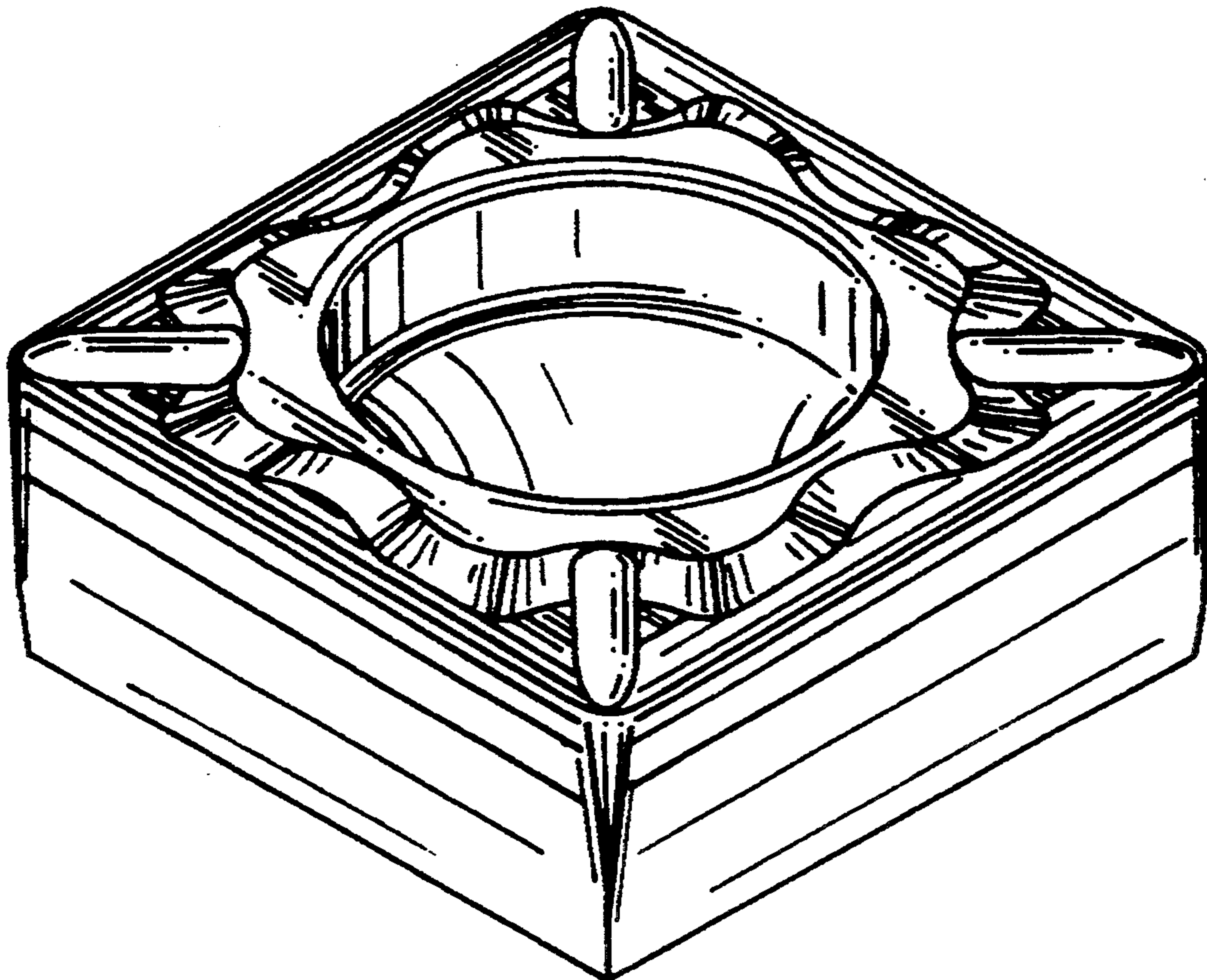

FIG. 1

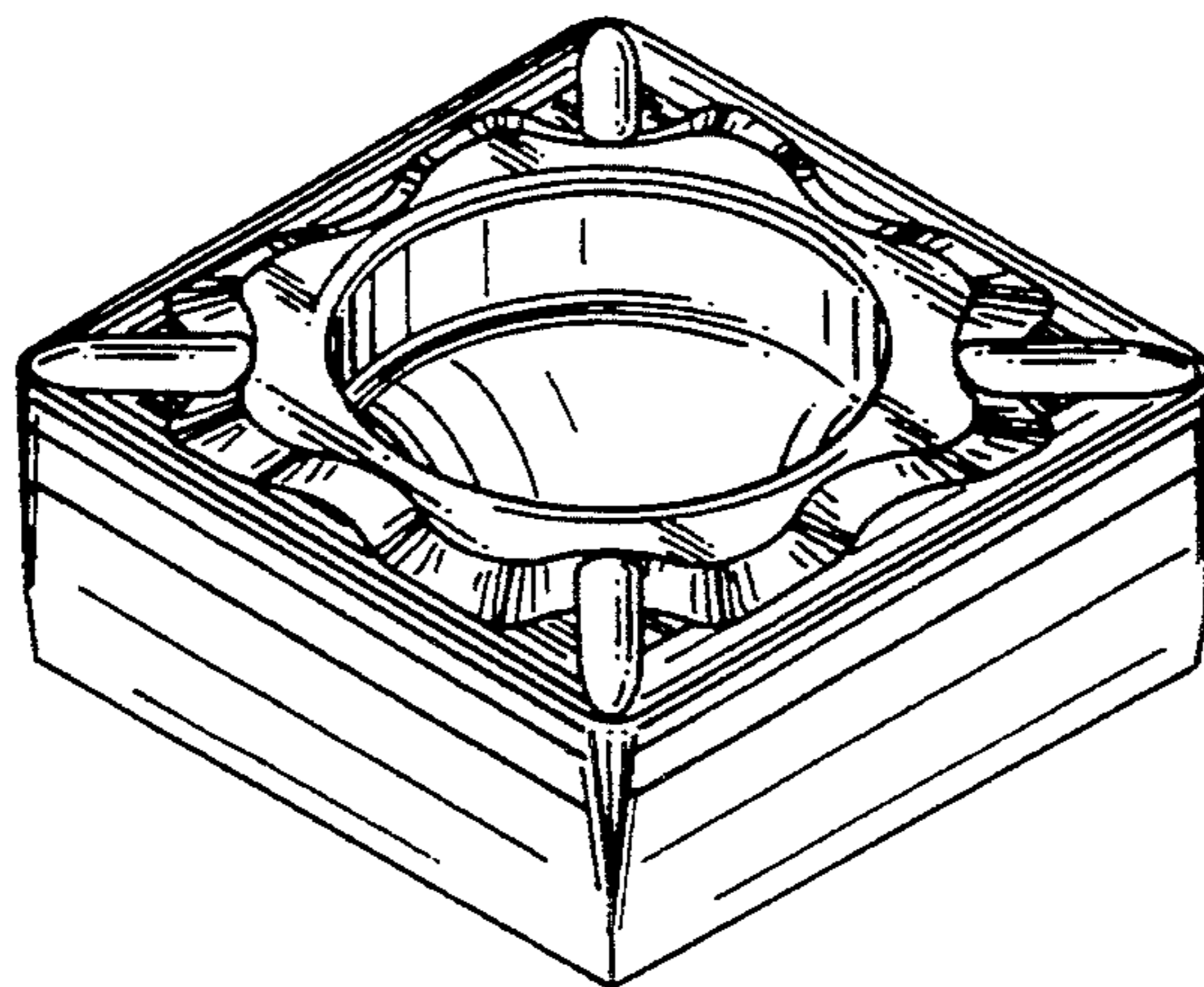

FIG. 2

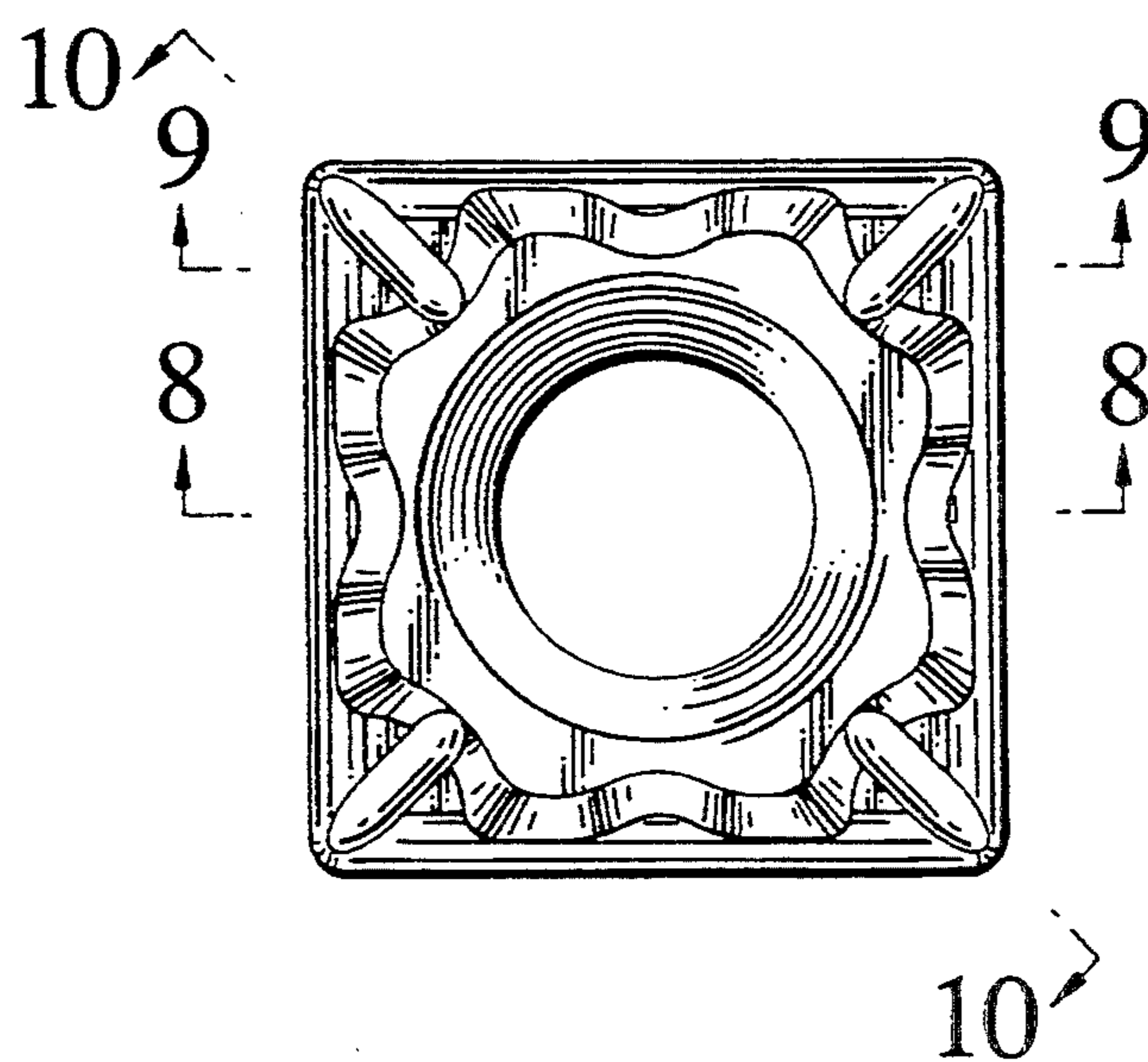

FIG.3

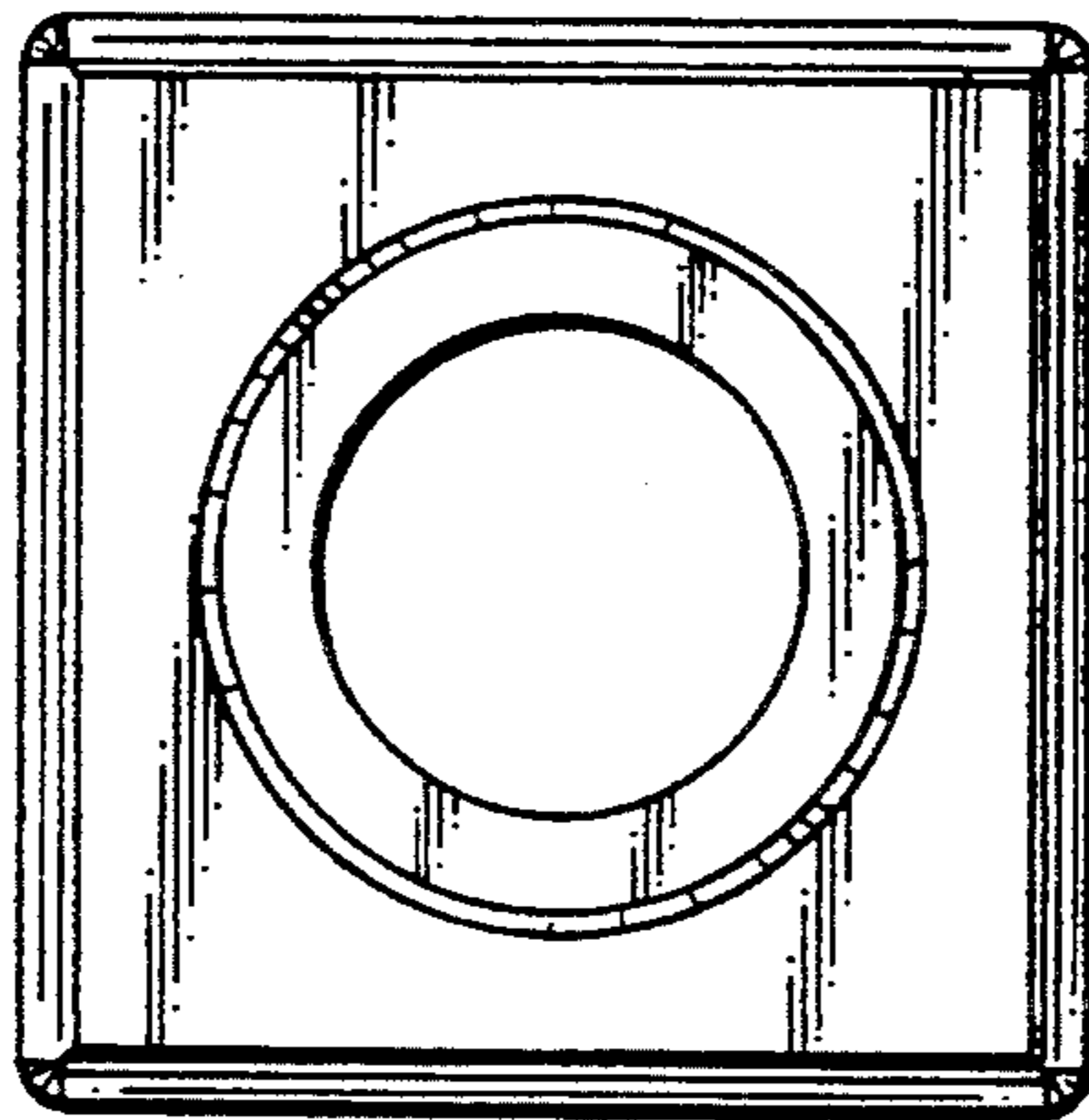

FIG.4

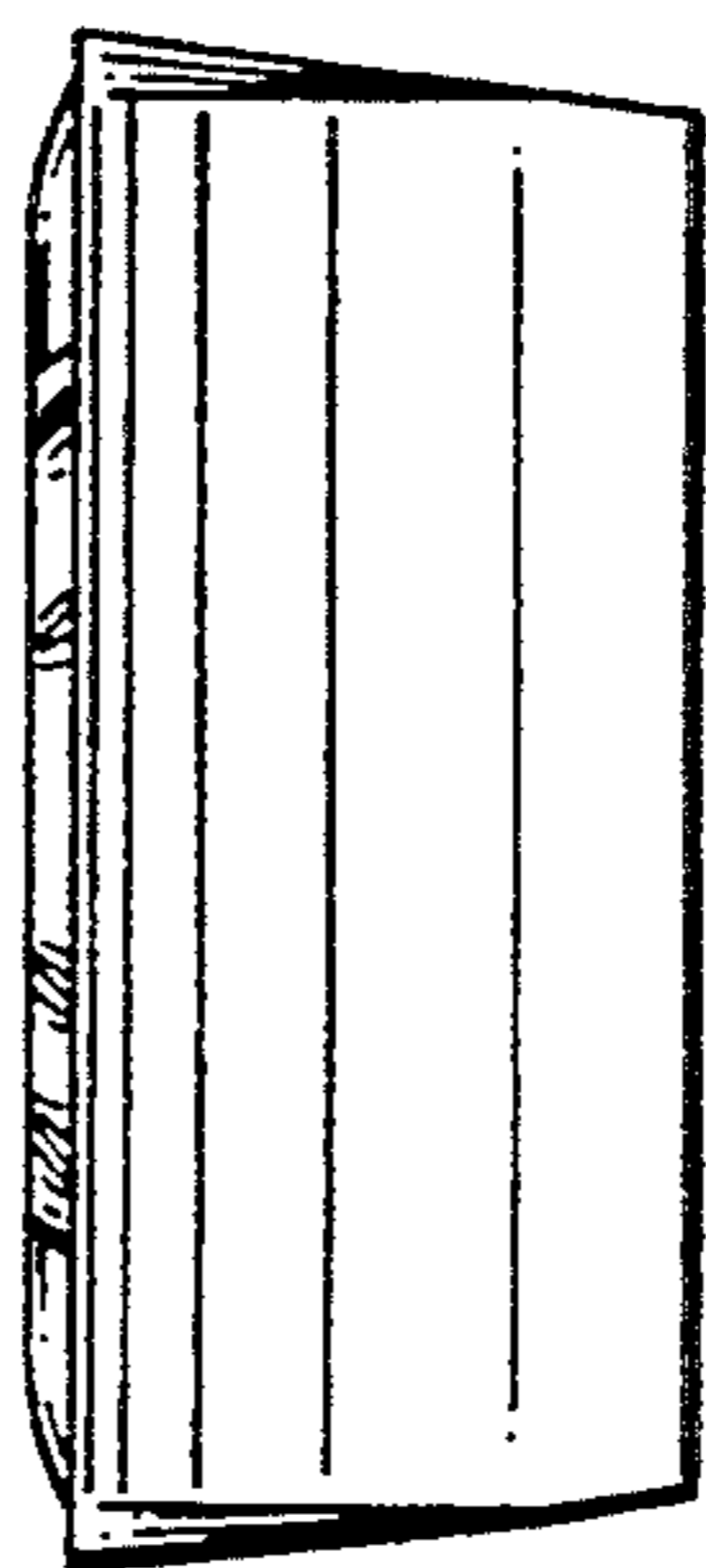

FIG.5

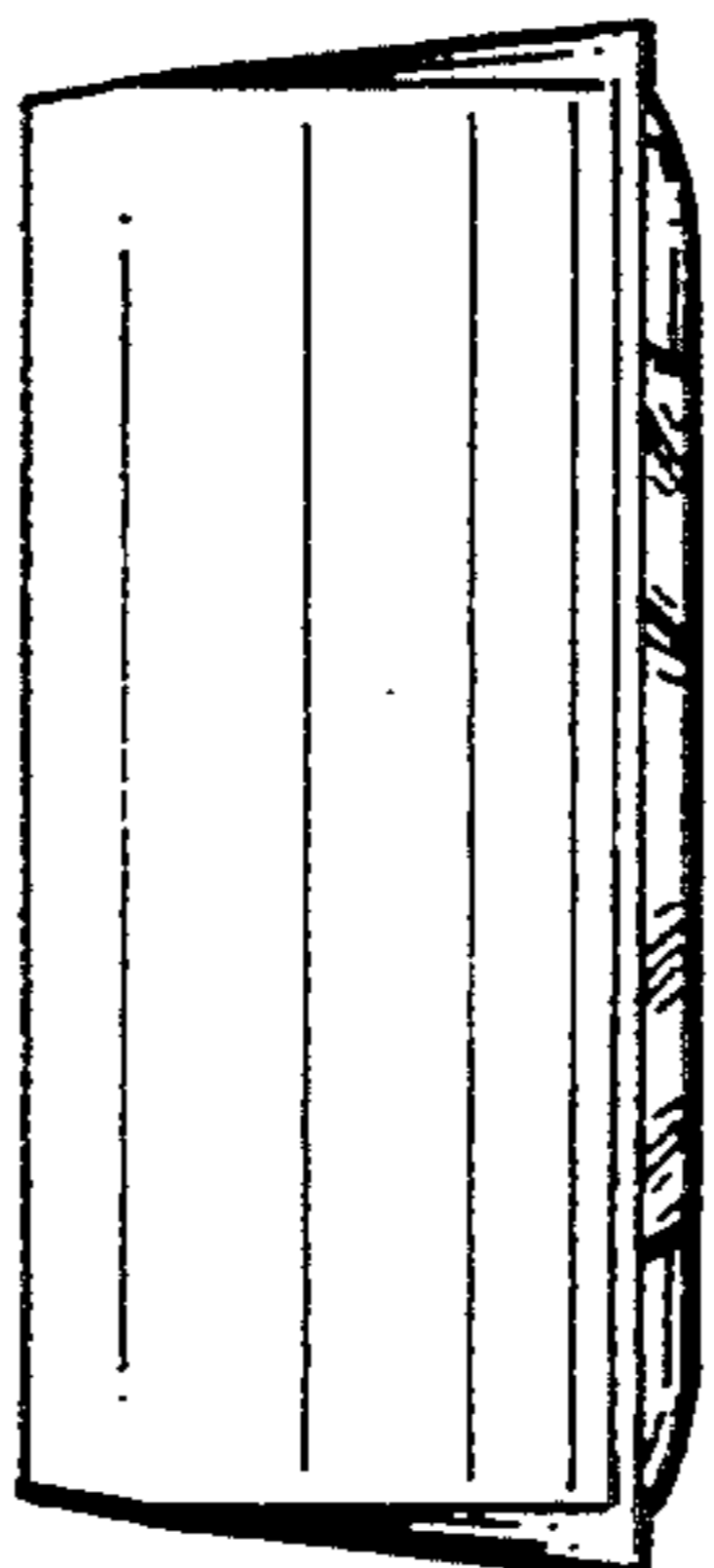

FIG.6

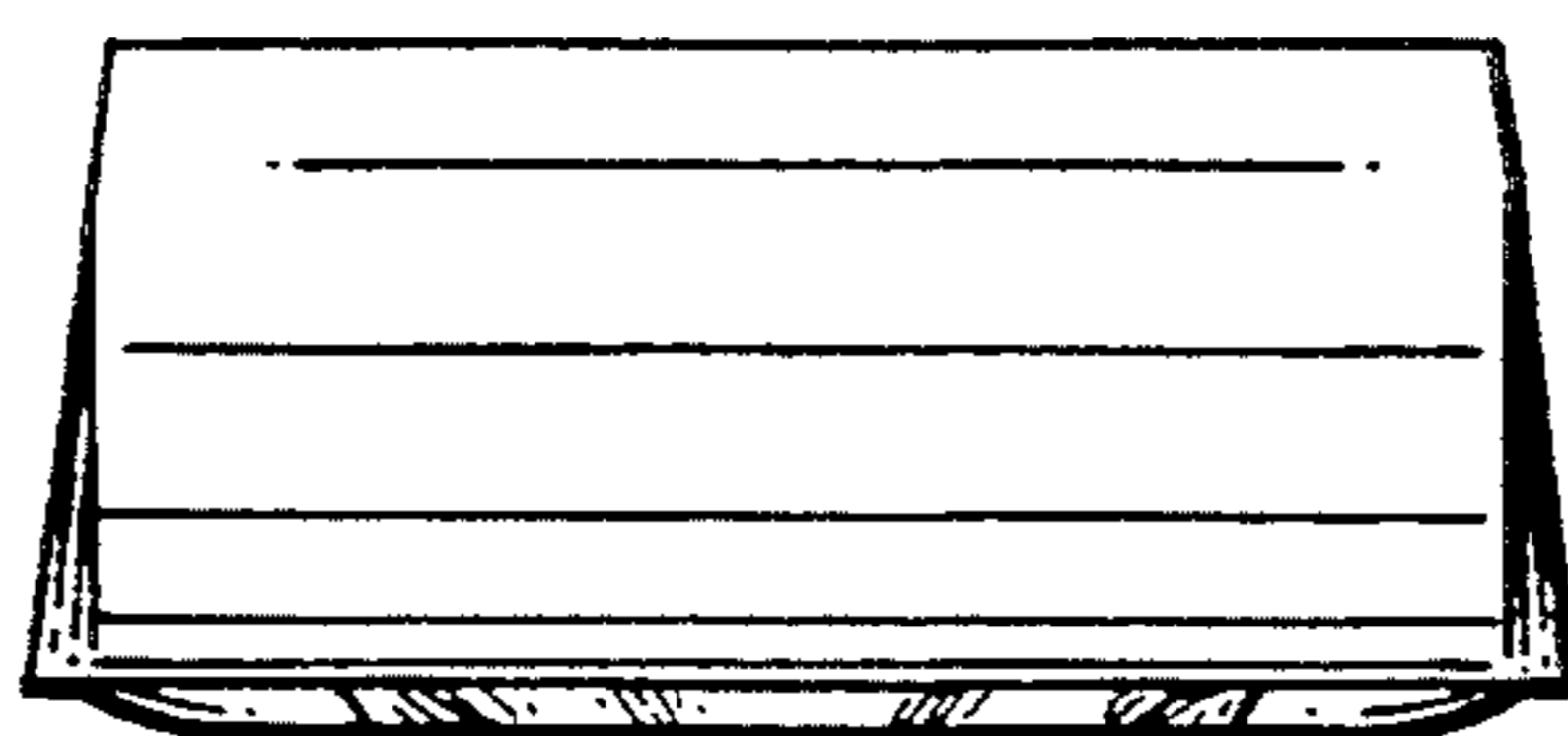

FIG.7

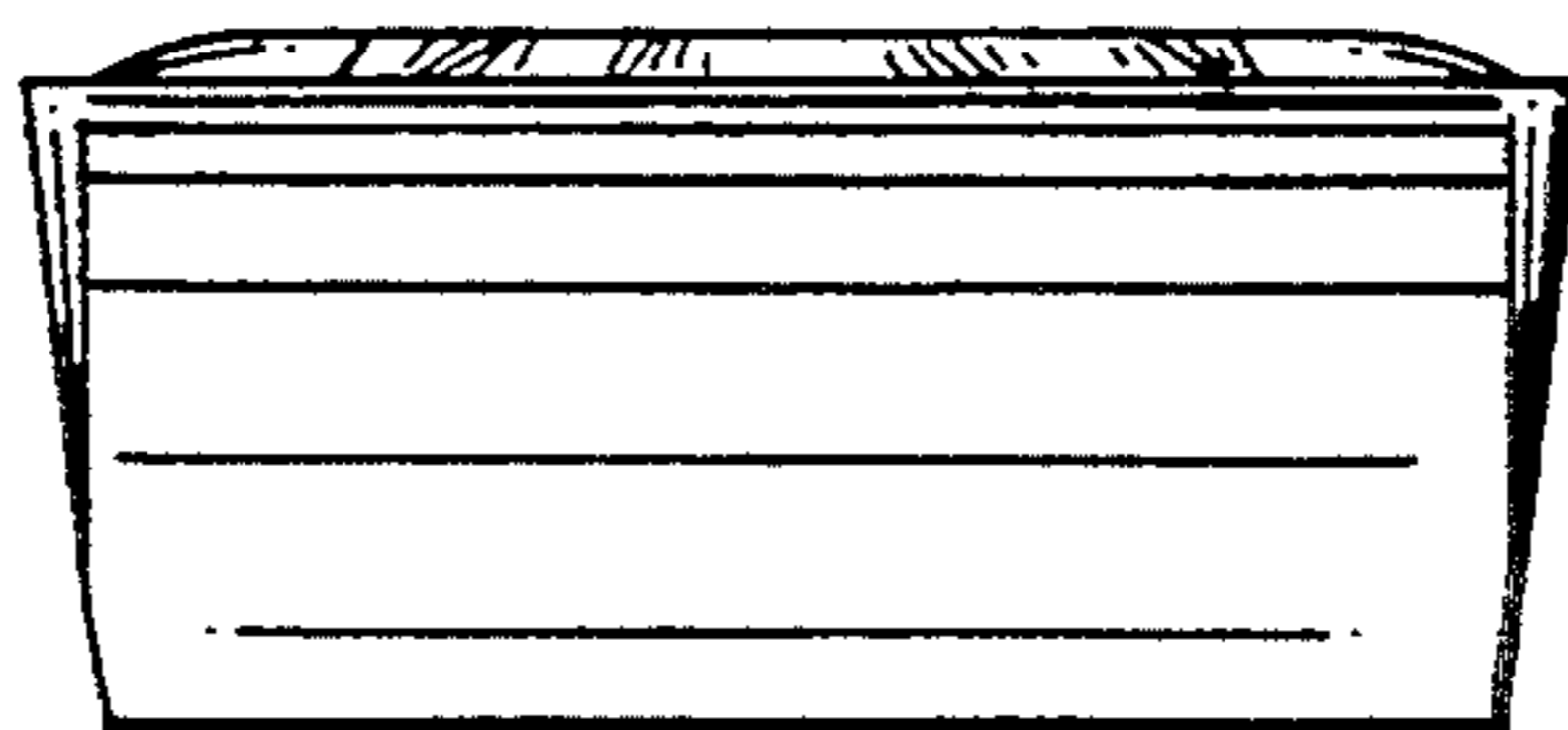

FIG.8

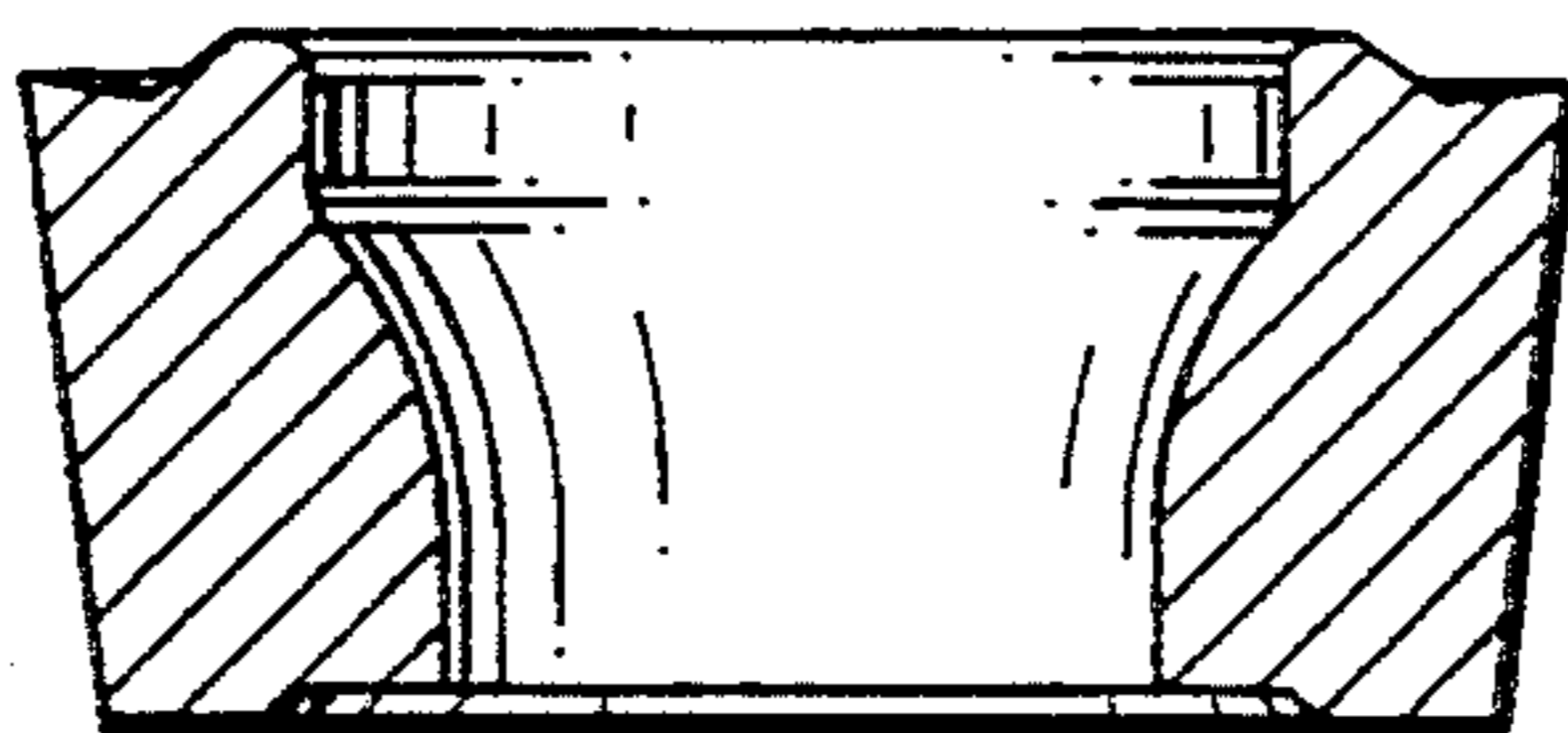

FIG. 9

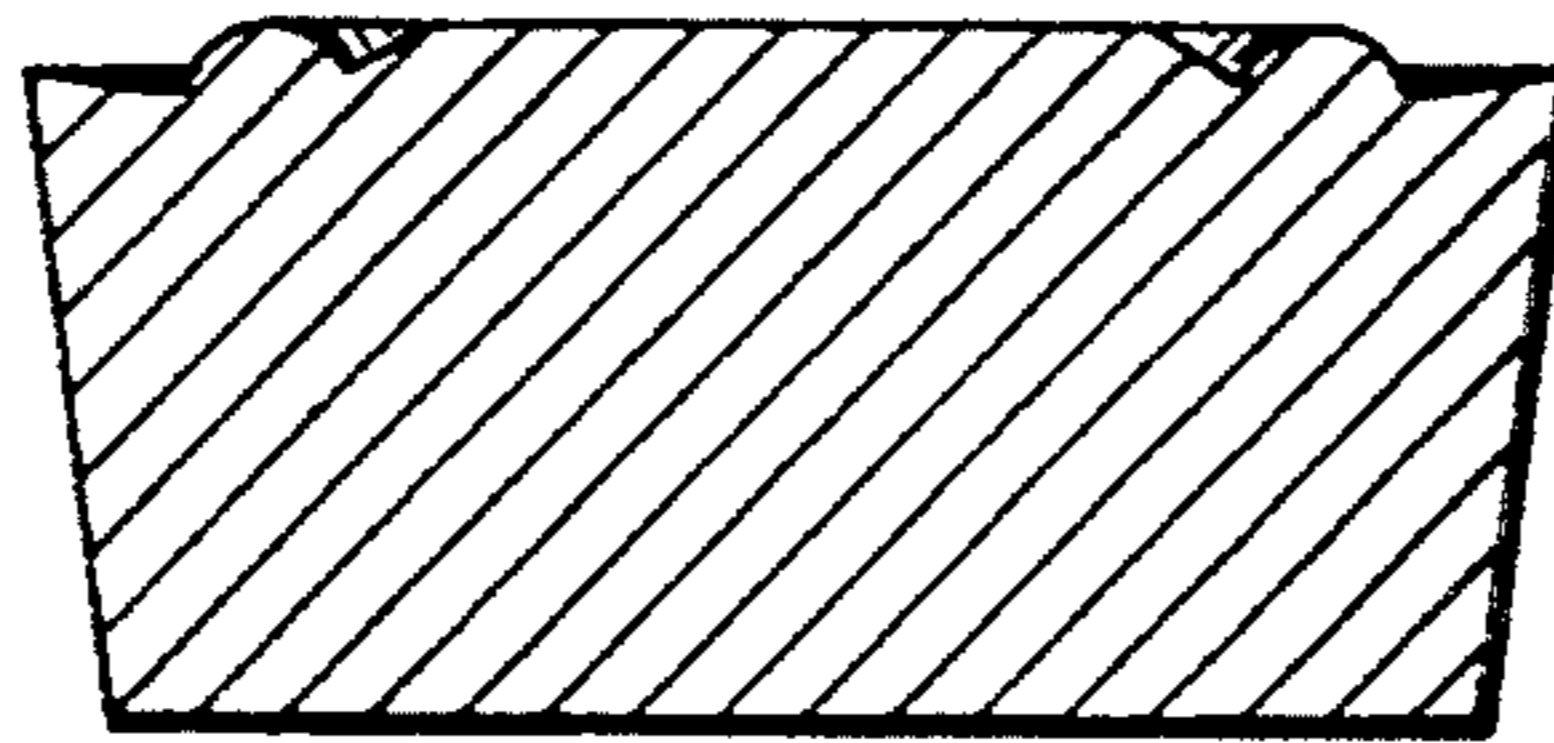

FIG. 10

