



US00D357647S

# United States Patent [19]

[11] Patent Number: **Des. 357,647**

**Blum**

[45] Date of Patent: **\*\* Apr. 25, 1995**

[54] **GROUND EFFECT VEHICLE**

[76] Inventor: **Albert Blum**, Brüsseler Strasse 6,  
D-5210 Troisdorf-Spich, Germany

[\*\*] Term: **14 Years**

[21] Appl. No.: **2,499**

[22] Filed: **Dec. 10, 1992**

[30] **Foreign Application Priority Data**

Jun. 12, 1992 [DE] Germany ..... M 92 04 356.9

[52] U.S. Cl. .... **D12/5; D12/327**

[58] Field of Search ..... **D12/5, 327, 4; 180/115,  
180/116, 117, 118, 120, 123, 125, 127; 244/2,  
12.6, 36, 46, 50**

[56] **References Cited**

**U.S. PATENT DOCUMENTS**

D. 209,252	11/1967	Foote	.....	D12/327
D. 217,839	6/1970	Gluhareff	.....	D12/327
D. 218,262	8/1970	Thomas	.....	D12/5
D. 232,168	7/1974	Leoni	.....	D12/327
D. 324,674	11/1991	Chia	.....	D12/5
2,989,269	6/1961	LeBel	.....	D12/4
3,908,783	9/1975	Joerg et al.	.....	180/116
4,046,215	9/1977	Hietanen et al.	.....	180/120
4,151,893	5/1979	Mantle	.....	180/116
4,757,962	7/1988	Grant	.....	180/116
5,186,415	2/1993	Li	.....	180/117

**OTHER PUBLICATIONS**

Flight International Aug. 1985 p. 36, the single seat  
sceptre plane.

*Primary Examiner*—James M. Gandy  
*Assistant Examiner*—M. Brown  
*Attorney, Agent, or Firm*—Brooks & Kushman

[57] **CLAIM**

The ornamental design for a ground effect vehicle, as  
shown and described.

**DESCRIPTION**

FIG. 1 is a perspective view of a ground effect vehicle showing my new design;  
 FIG. 2 is a top plan view of the design, the tail unit of which is a double tail unit;  
 FIG. 3 is a front elevational view of the ground effect vehicle, the tail unit of which is a double tail unit;  
 FIG. 4 is a right side view of the design, the tail unit of which is a double tail unit;  
 FIG. 5 is a bottom plan view of the design, the tail unit of which is a double tail unit;  
 FIG. 6 is a rear view of the design, the tail unit of which is a double tail unit;  
 FIG. 7 is a perspective view of a ground effect vehicle showing a second embodiment of my new design;  
 FIG. 8 is a top plan view of the design, the tail unit of which is a single tail unit;  
 FIG. 9 is a front elevational view of the ground effect vehicle, the tail unit of which is a single tail unit;  
 FIG. 10 is a right side view of the design, the tail unit of which is a single tail unit;  
 FIG. 11 is a bottom plan view of the design, the tail unit of which is a single tail unit; and,  
 FIG. 12 is a rear view of the design, the tail unit of which is a single tail unit.

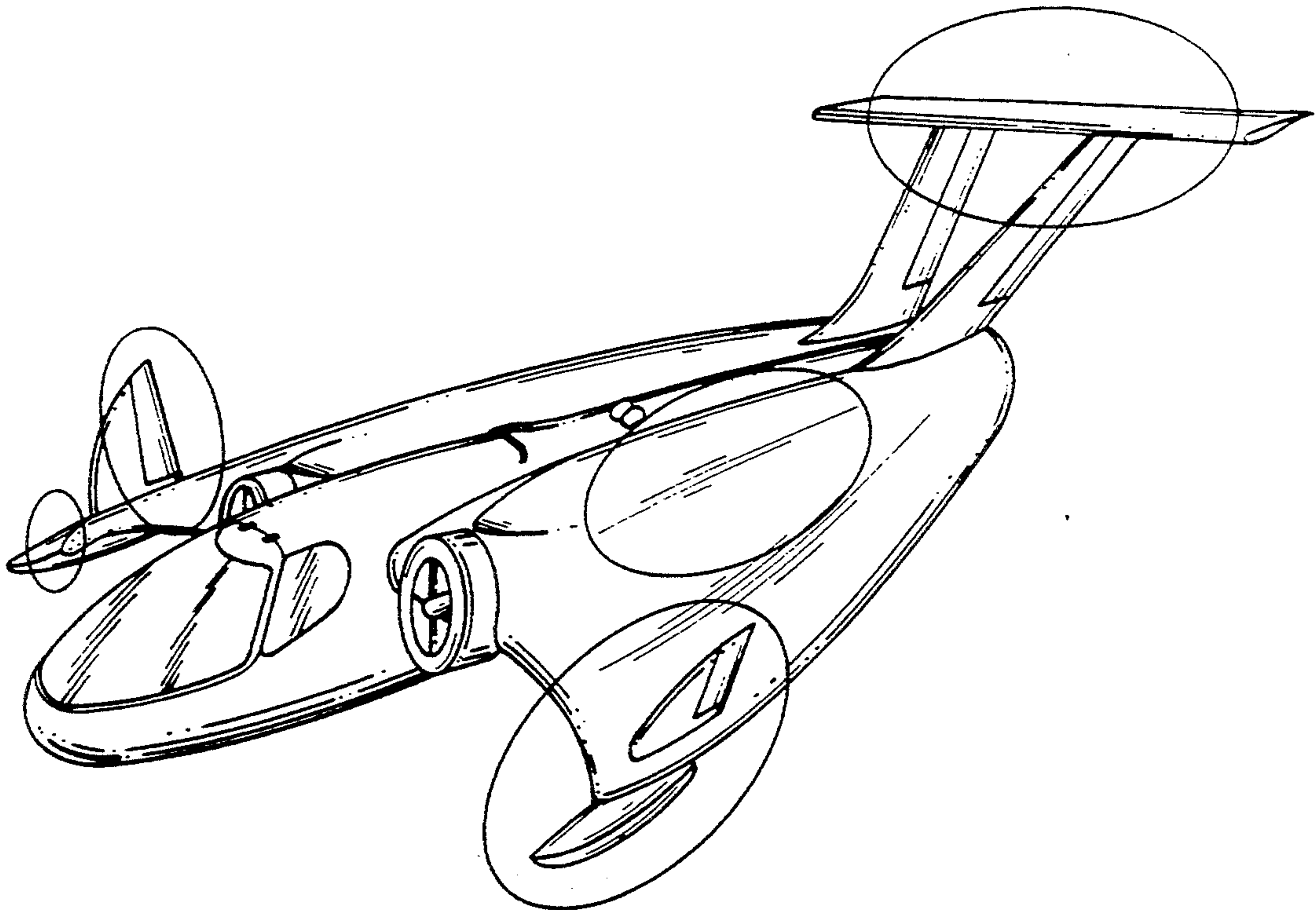

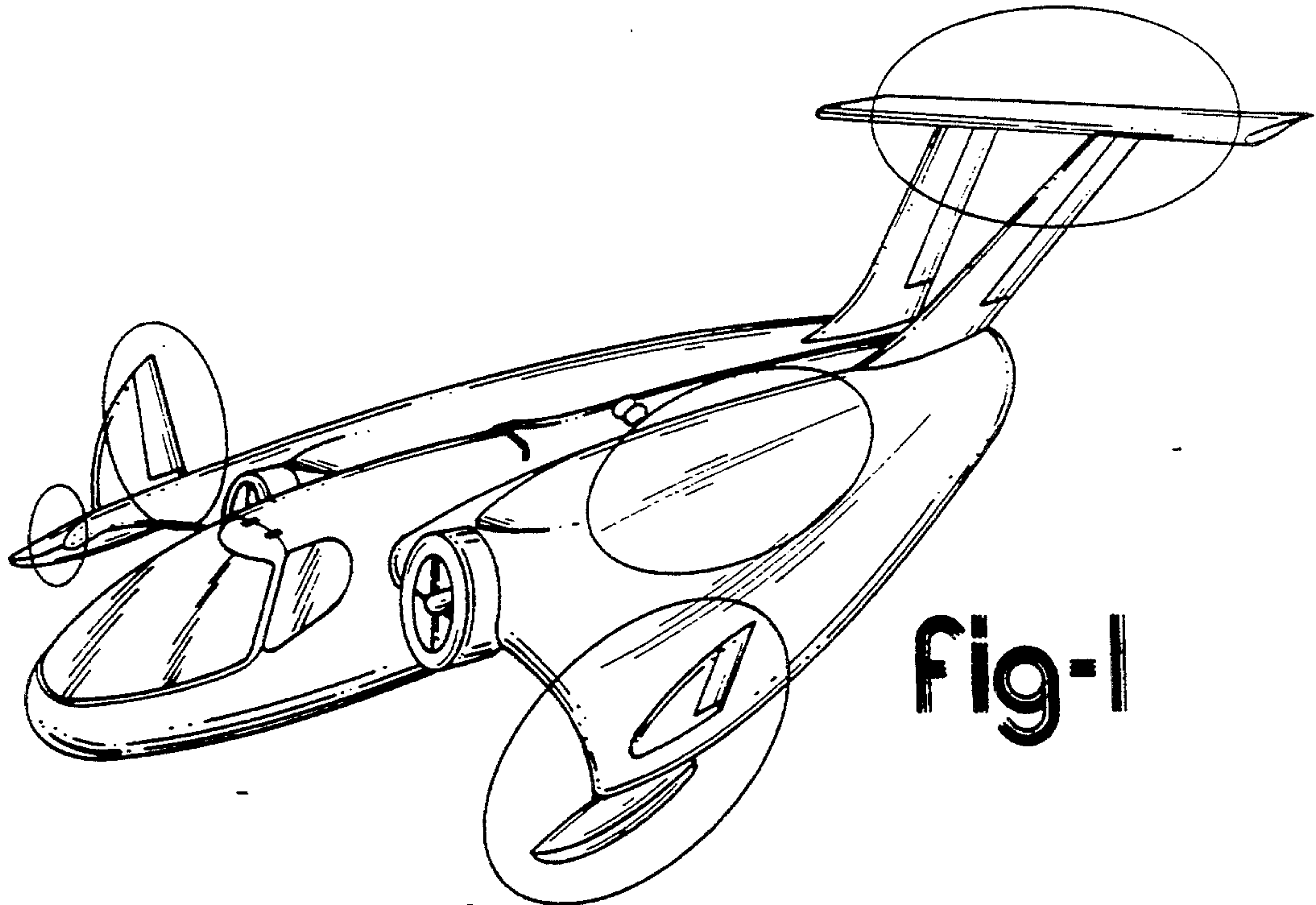

fig-1

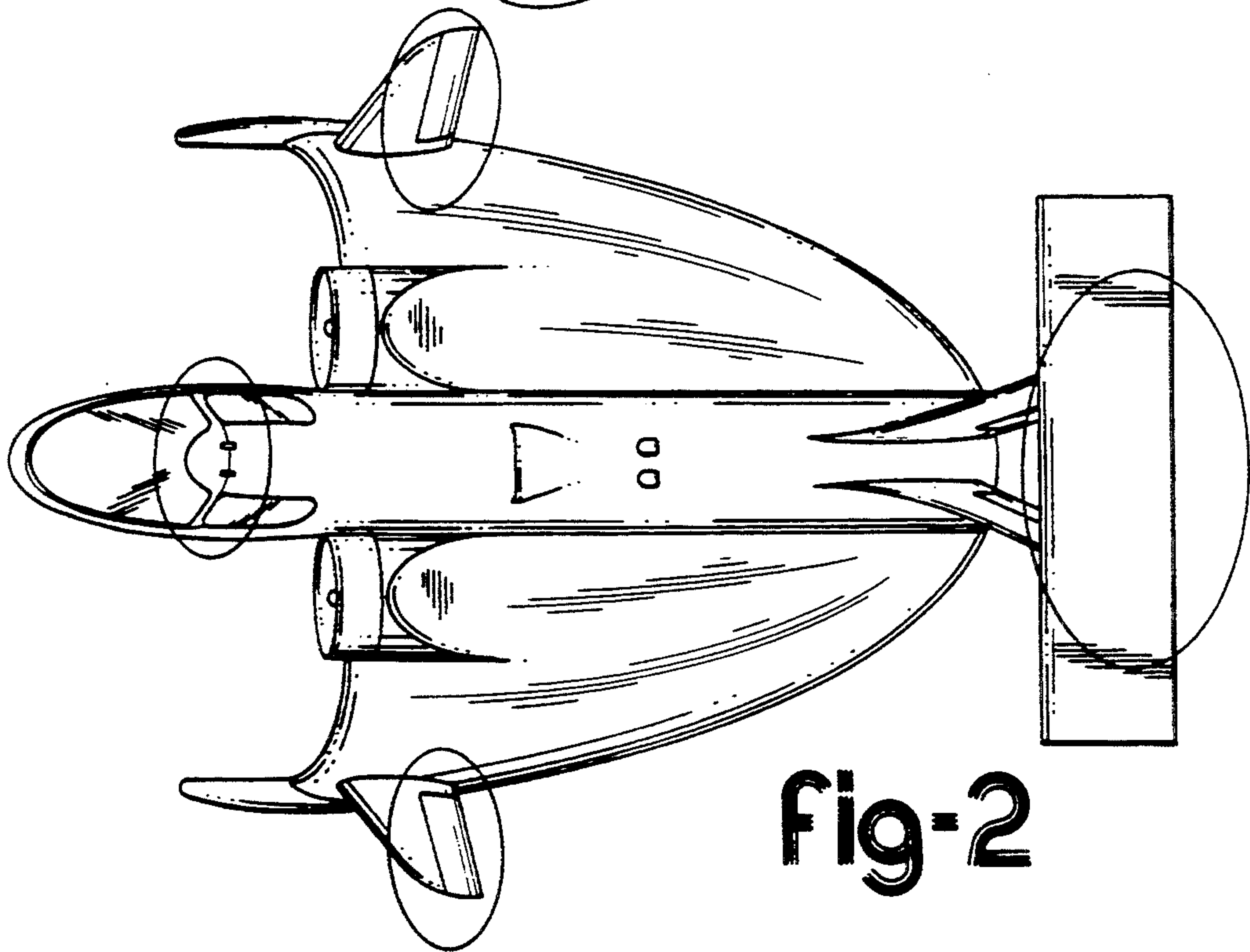

fig-2

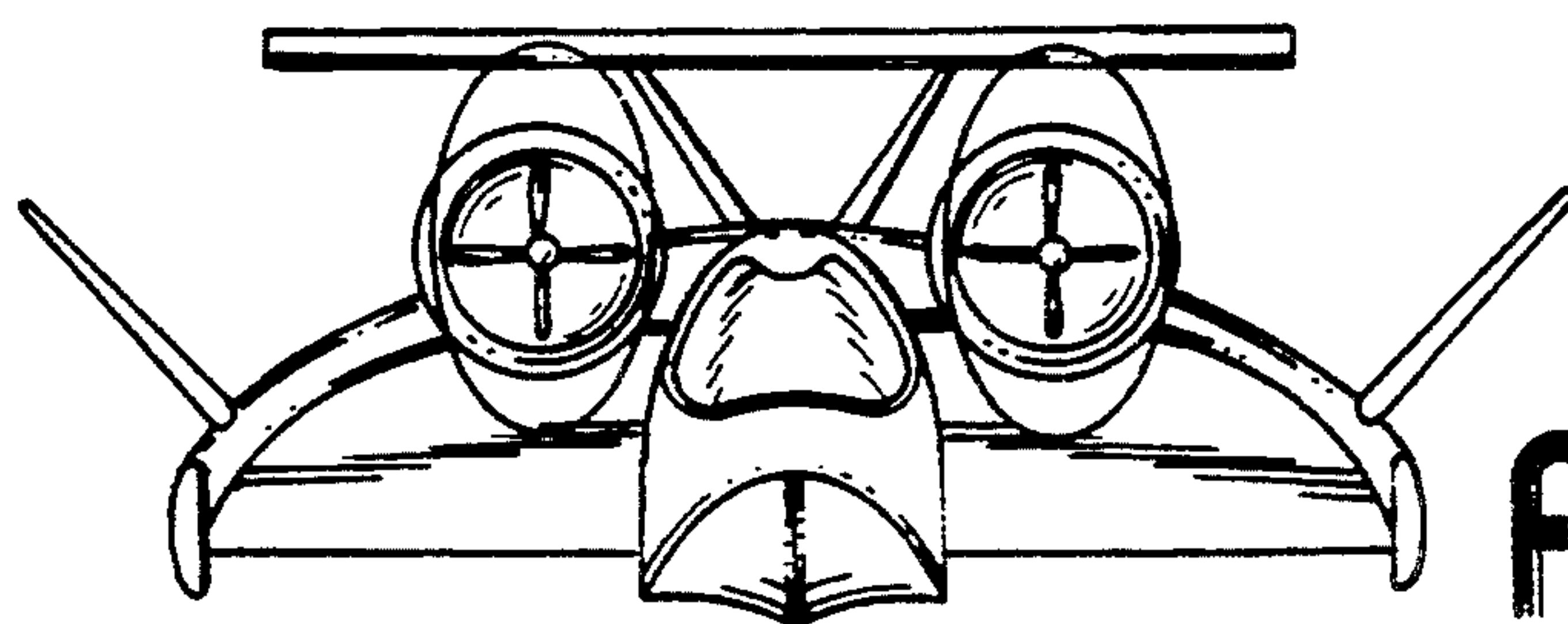

fig-3



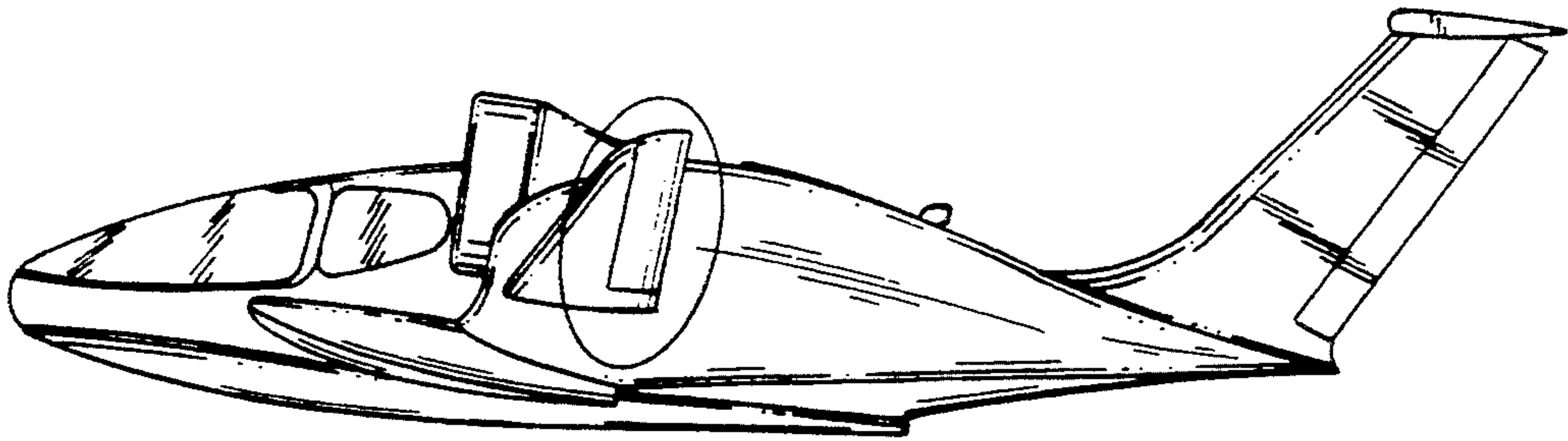

fig-4

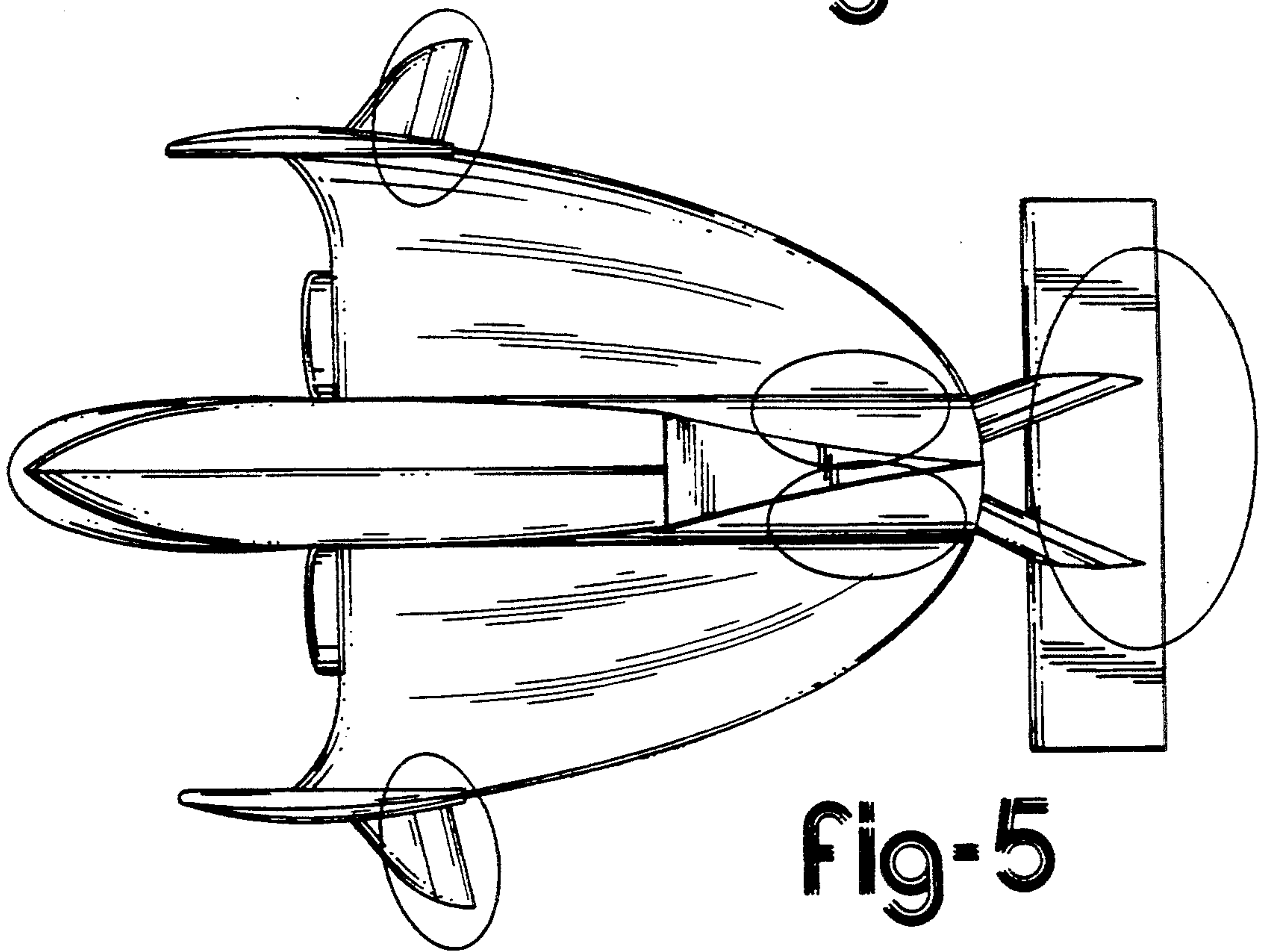

fig-5

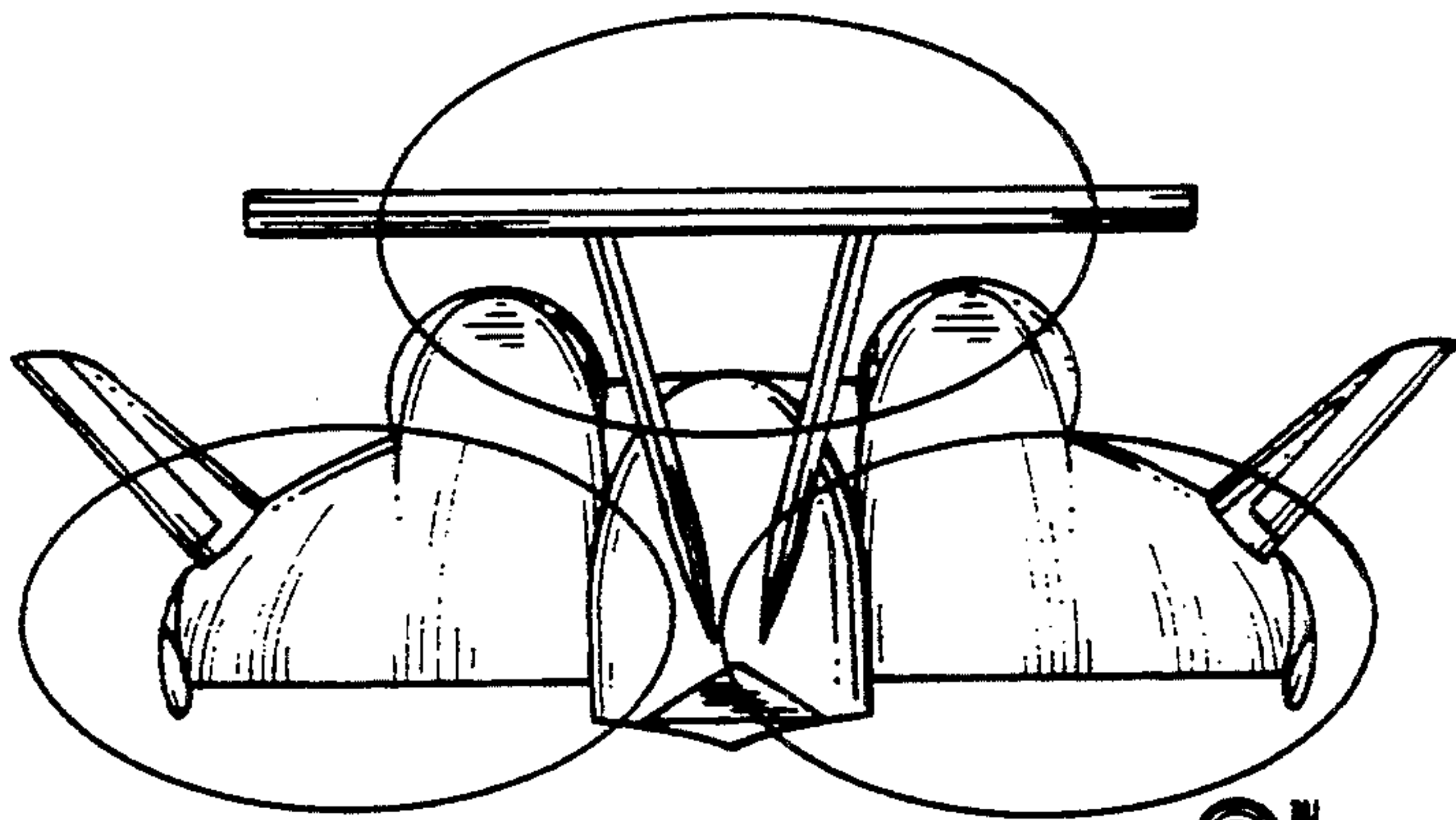

fig-6

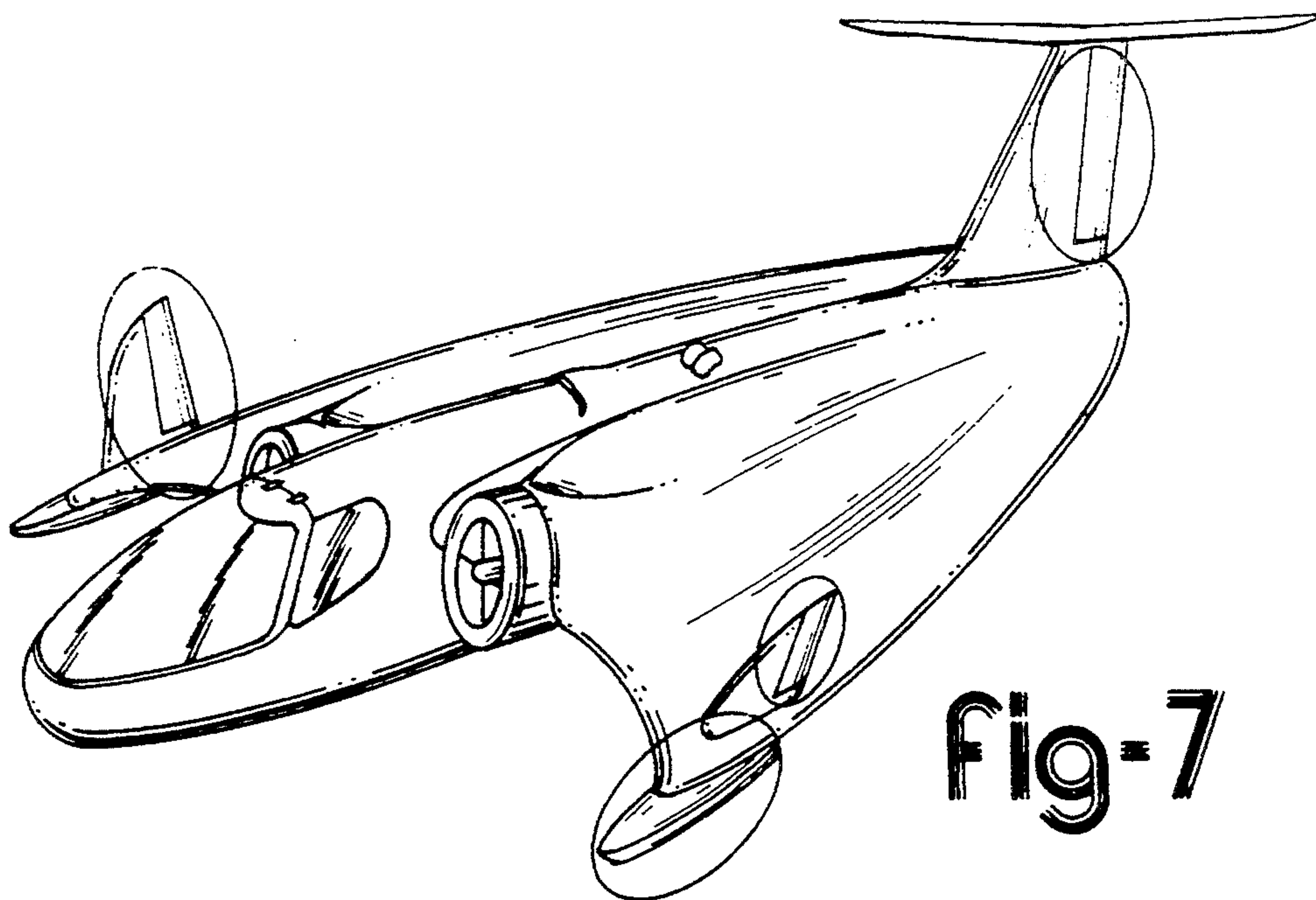

Fig-7

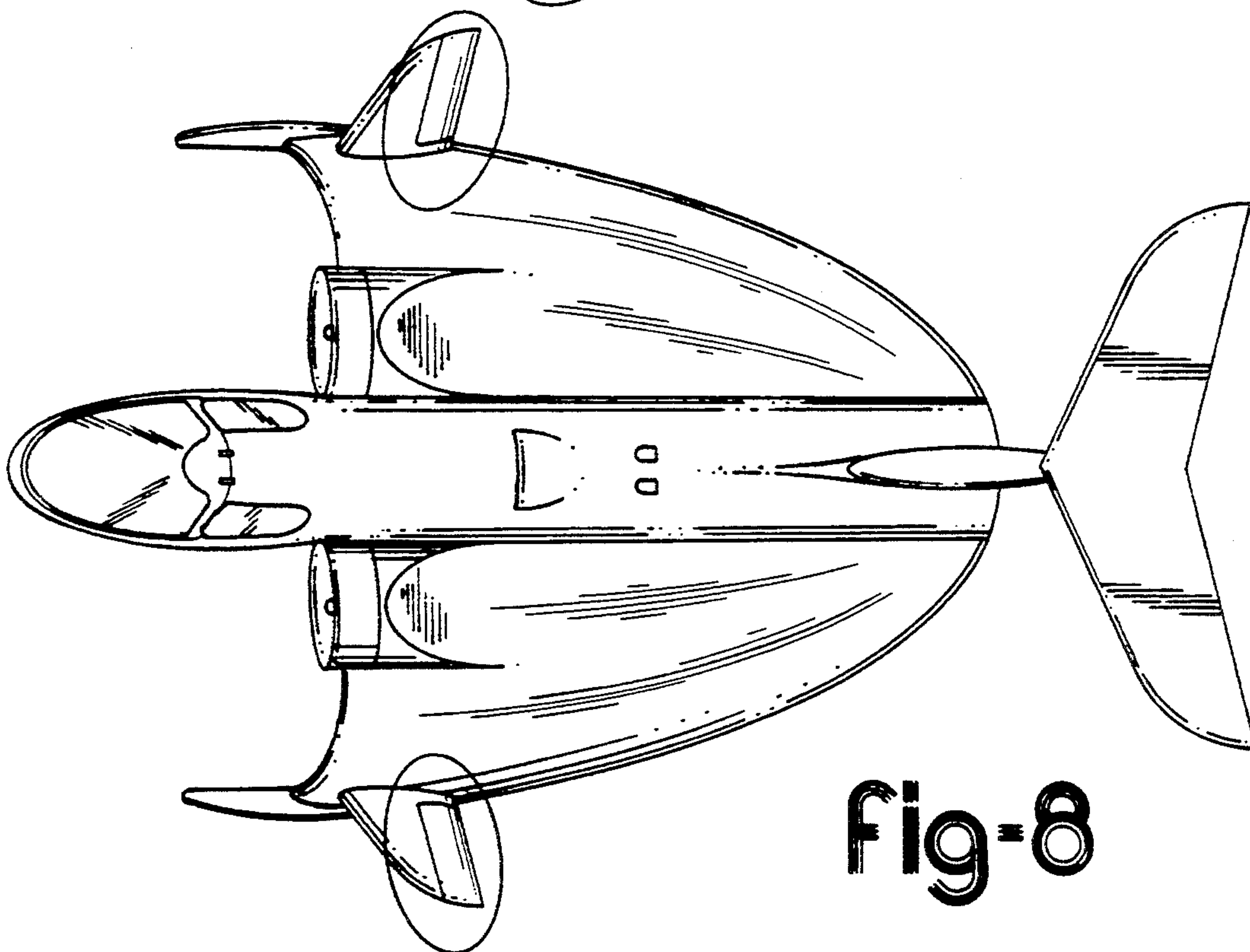

Fig-8

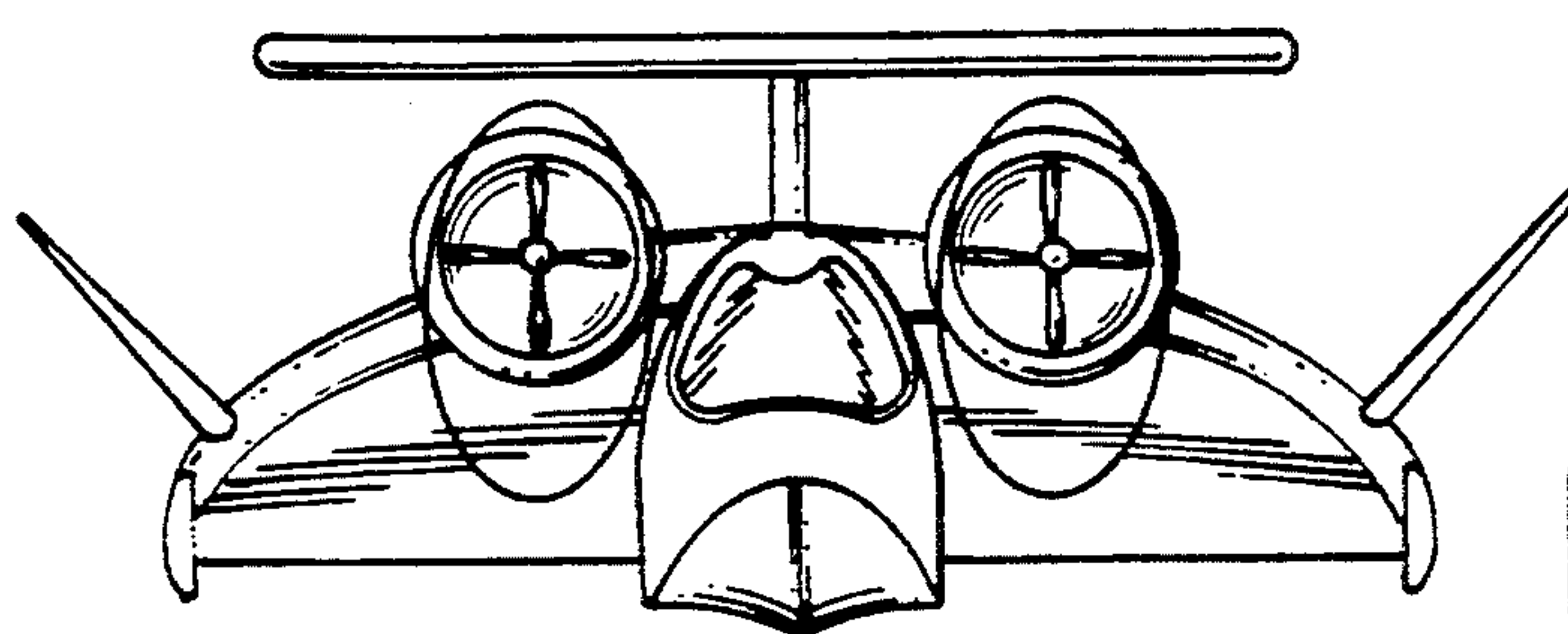

Fig-9

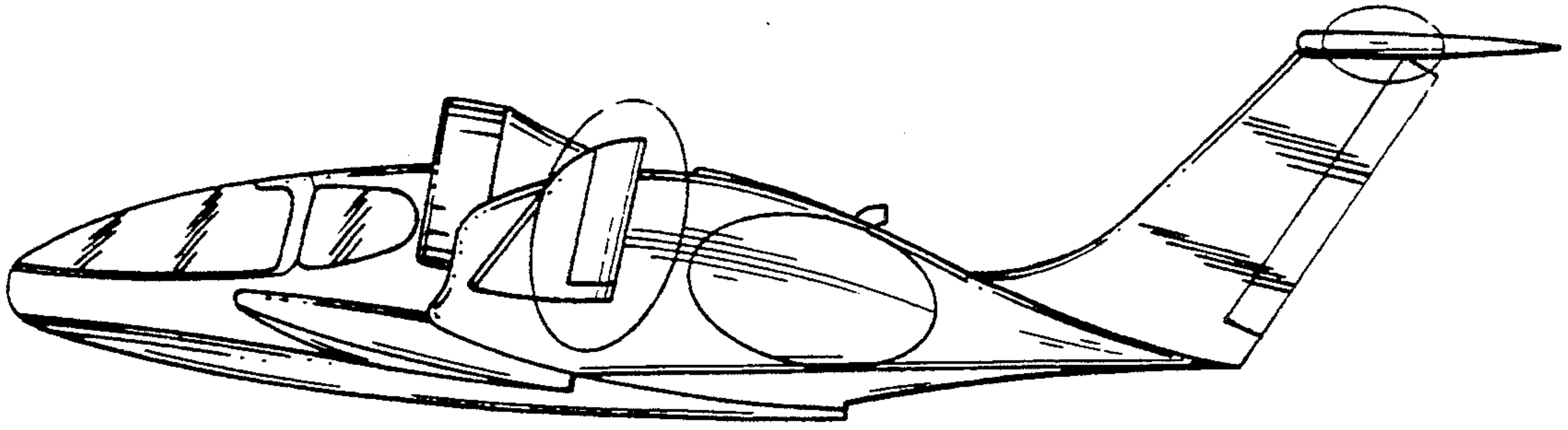

Fig-10

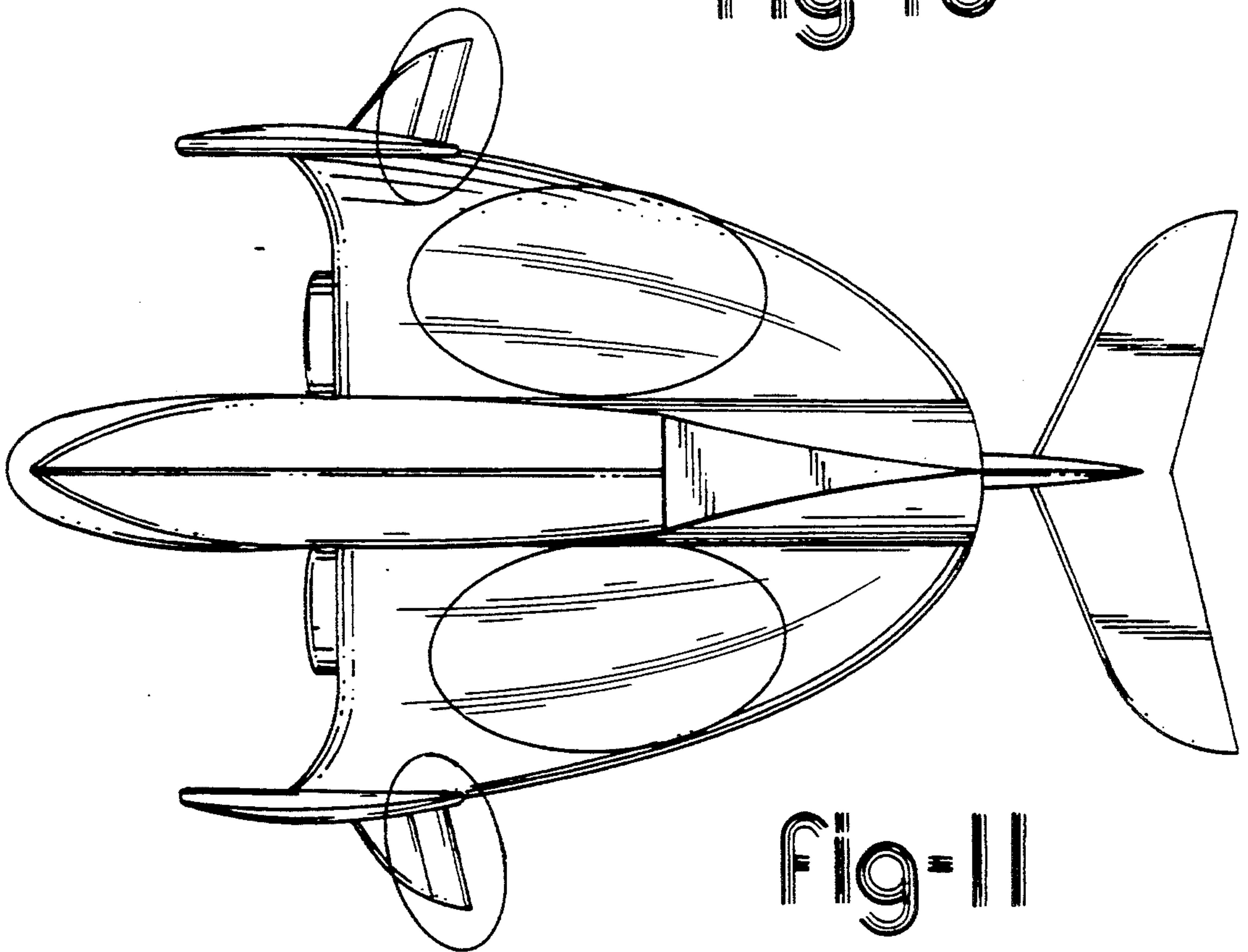

Fig-11

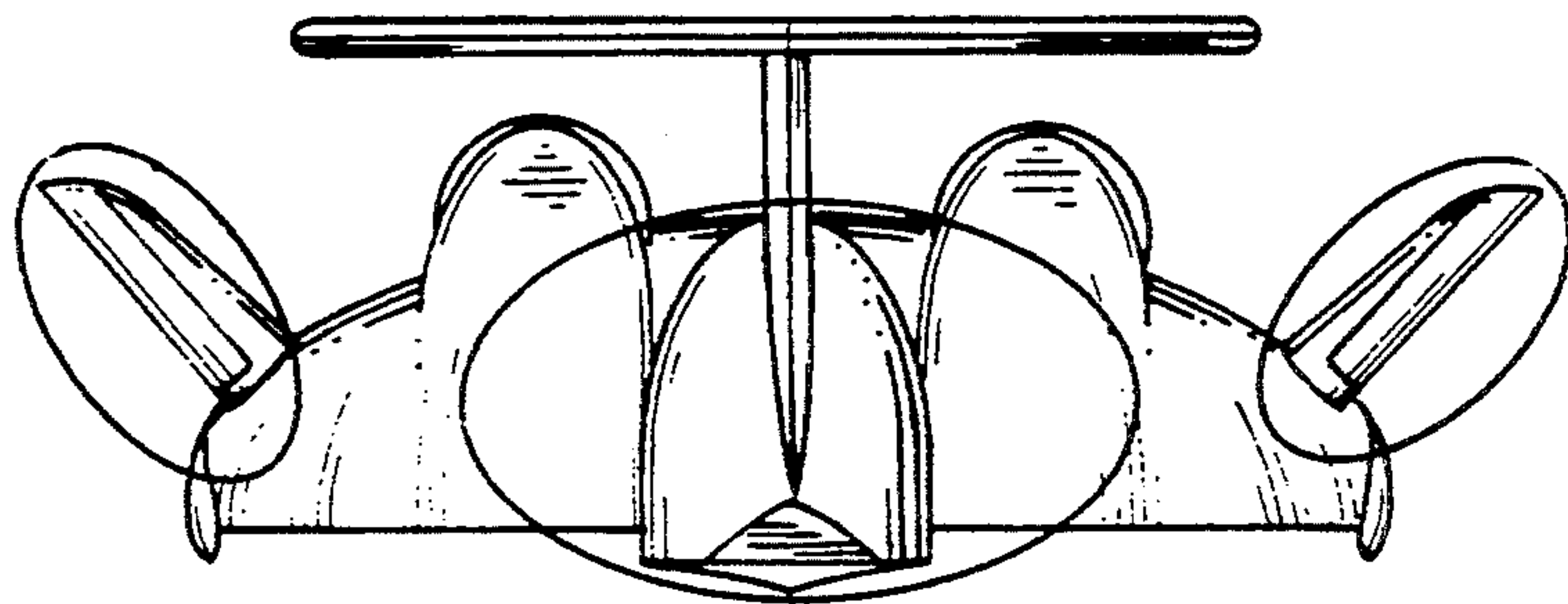

Fig-12