



US00D357354S

United States Patent [19]

Marchwiak et al.

[11] Patent Number: Des. 357,354

[45] Date of Patent: ** Apr. 18, 1995

[54] CARRYING CASE WITH BUILT-IN CART

- [75] Inventors: **Zbigniew Marchwiak; Silvano Brugioni**, both of Chicago, Ill.
- [73] Assignee: **Travel Caddy, Inc.**, Chicago, Ill.
- [**] Term: **14 Years**
- [21] Appl. No.: **15,242**
- [22] Filed: **Nov. 9, 1993**
- [52] U.S. Cl. **D3/279; D3/276**
- [58] Field of Search **D3/273, 276, 279; 190/100, 115, 900, 901, 903**

[56] References Cited

U.S. PATENT DOCUMENTS

D. 270,017	8/1983	DiDonna	D3/279
D. 336,365	6/1993	Huong	D3/279
3,612,563	10/1971	Kazmark, Sr. .	
3,998,476	12/1976	Kazmark, Sr. .	
4,175,769	11/1979	Kazmark .	
4,221,402	9/1980	Kazmark .	
4,401,319	8/1983	Kazmark .	
4,630,837	12/1986	Kazmark .	
4,896,897	1/1990	Wilhelm .	
4,995,487	2/1991	Plath	190/115 X
5,124,458	6/1991	Kazmark et al. .	

OTHER PUBLICATIONS

"The Clipper Story," 1 page, one-sided brochure (no date shown on brochure).
 "Don't Carry Those Bags!!!," 1 page, one-sided brochure, Clipper Products, Cincinnati, Ohio (no date shown on brochure).

Primary Examiner—Theodore M. Shooman
Assistant Examiner—Dominic Simone
Attorney, Agent, or Firm—Fitch, Even, Tabin & Flannery

[57] CLAIM

The ornamental design for a carrying case with built-in cart, as shown and described.

DESCRIPTION

FIG. 1 is a front perspective view of a carrying case with built-in cart showing our new design;
 FIG. 2 is a front perspective view thereof, the handle in an extended position;
 FIG. 3 is a rear perspective view of FIG. 2;
 FIG. 4 is a front elevational view of FIG. 2;
 FIG. 5 is a right side elevational view of FIG. 2;
 FIG. 6 is a bottom plan view of FIG. 2;
 FIG. 7 is a top plan view of FIG. 2;
 FIG. 8 is a rear elevational view of FIG. 2; and,
 FIG. 9 is a left side elevational view of FIG. 2.

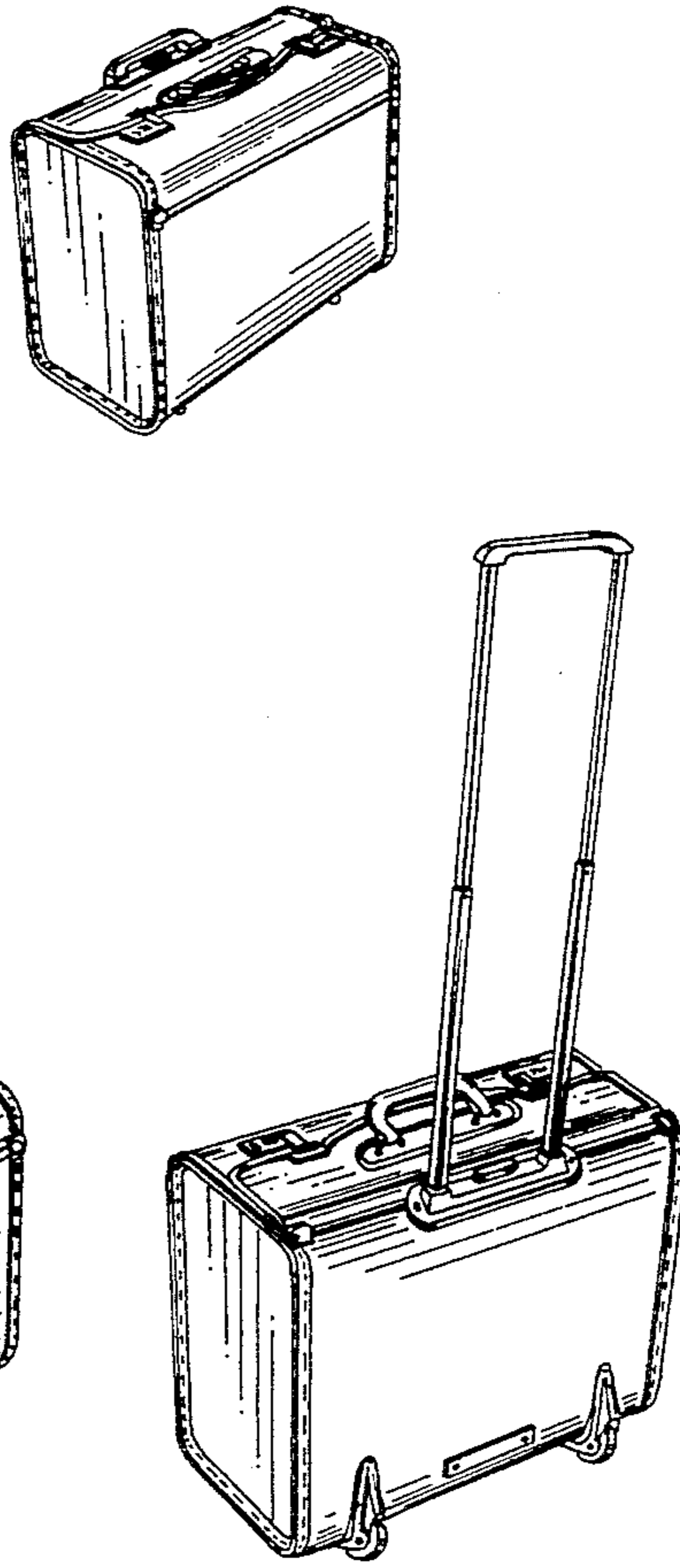

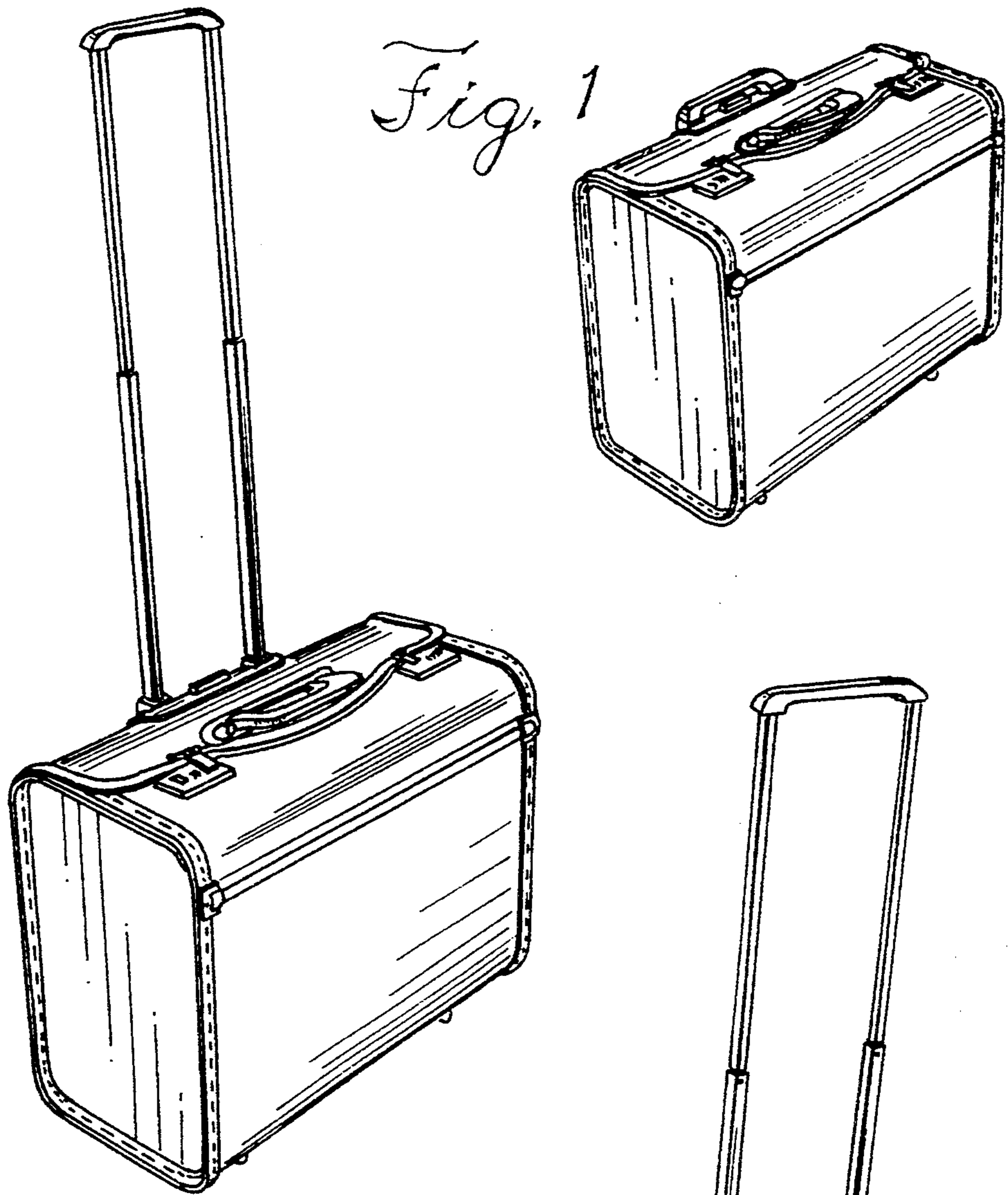

Fig. 2

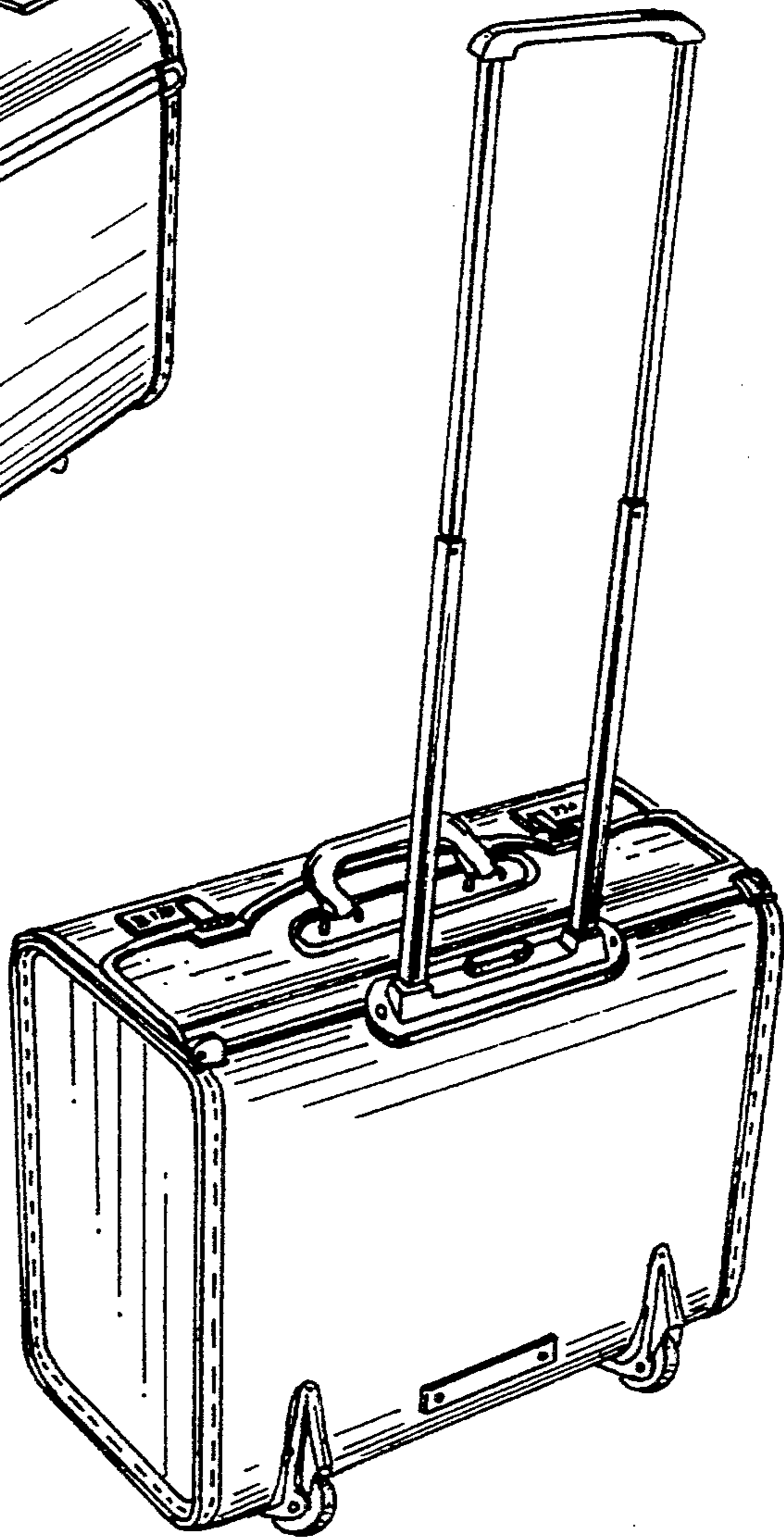

Fig. 3

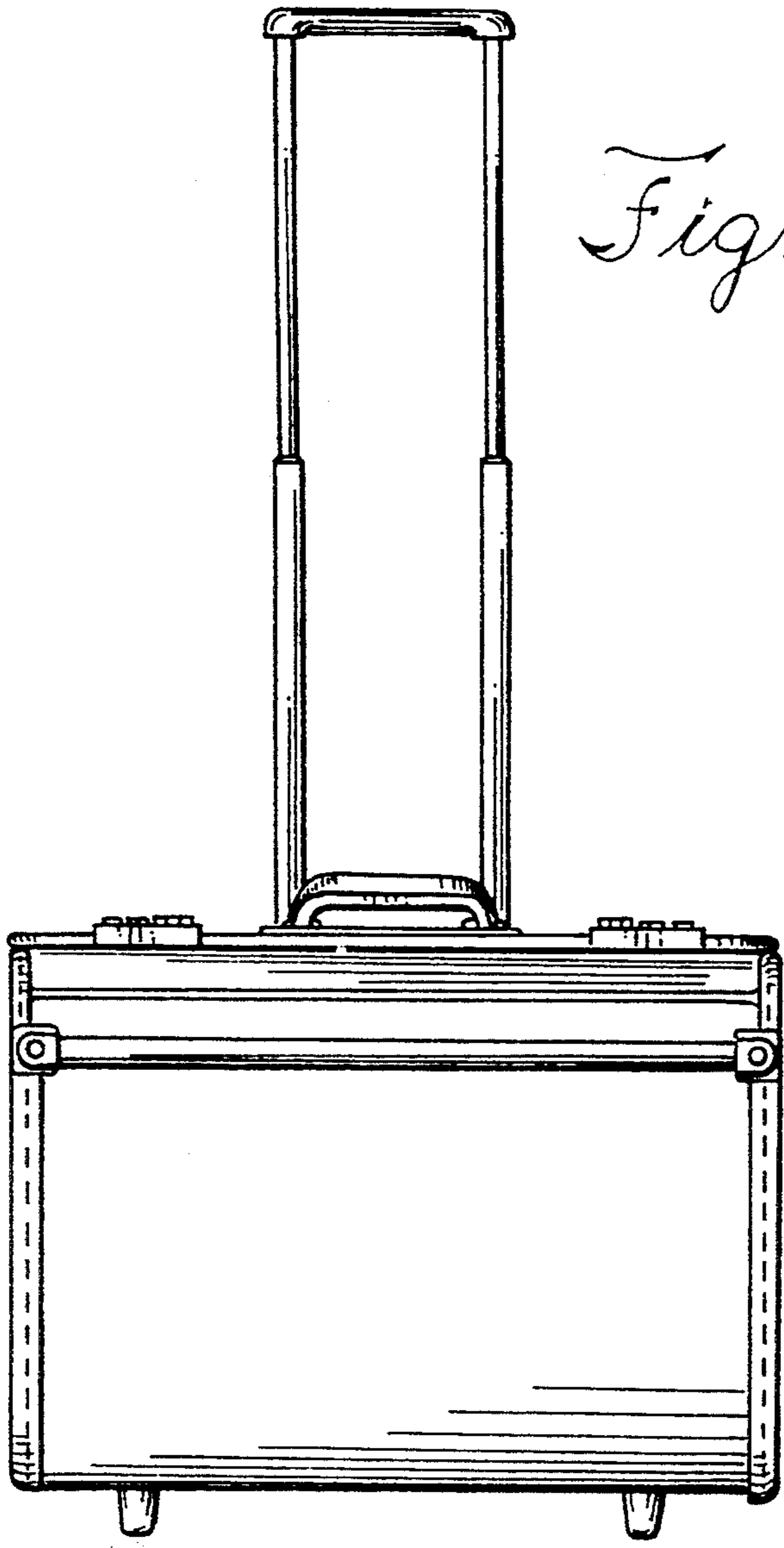

Fig. 4

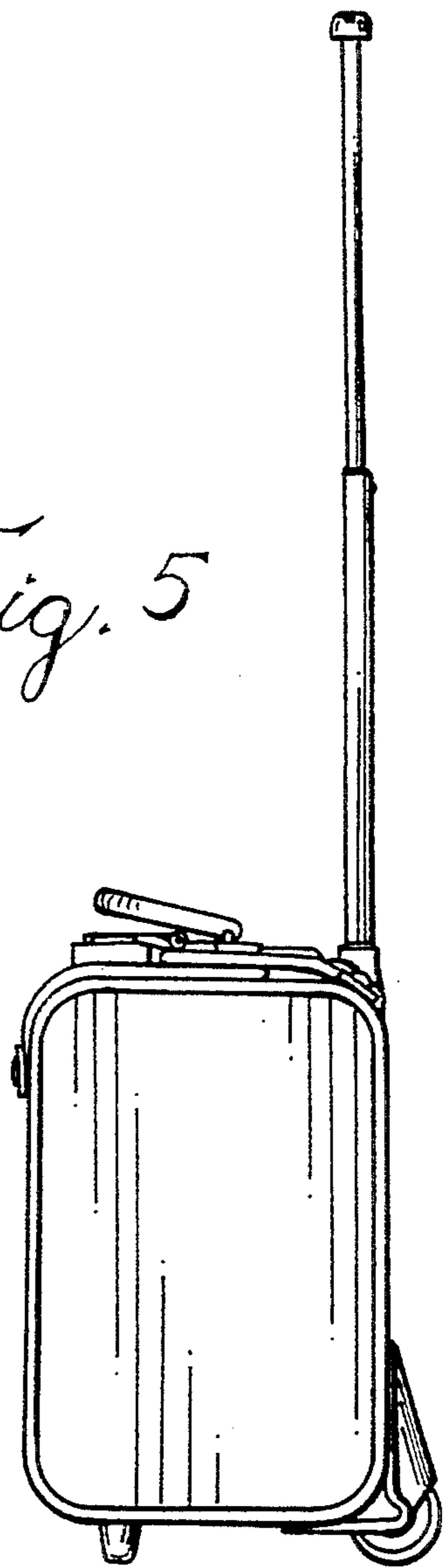

Fig. 5

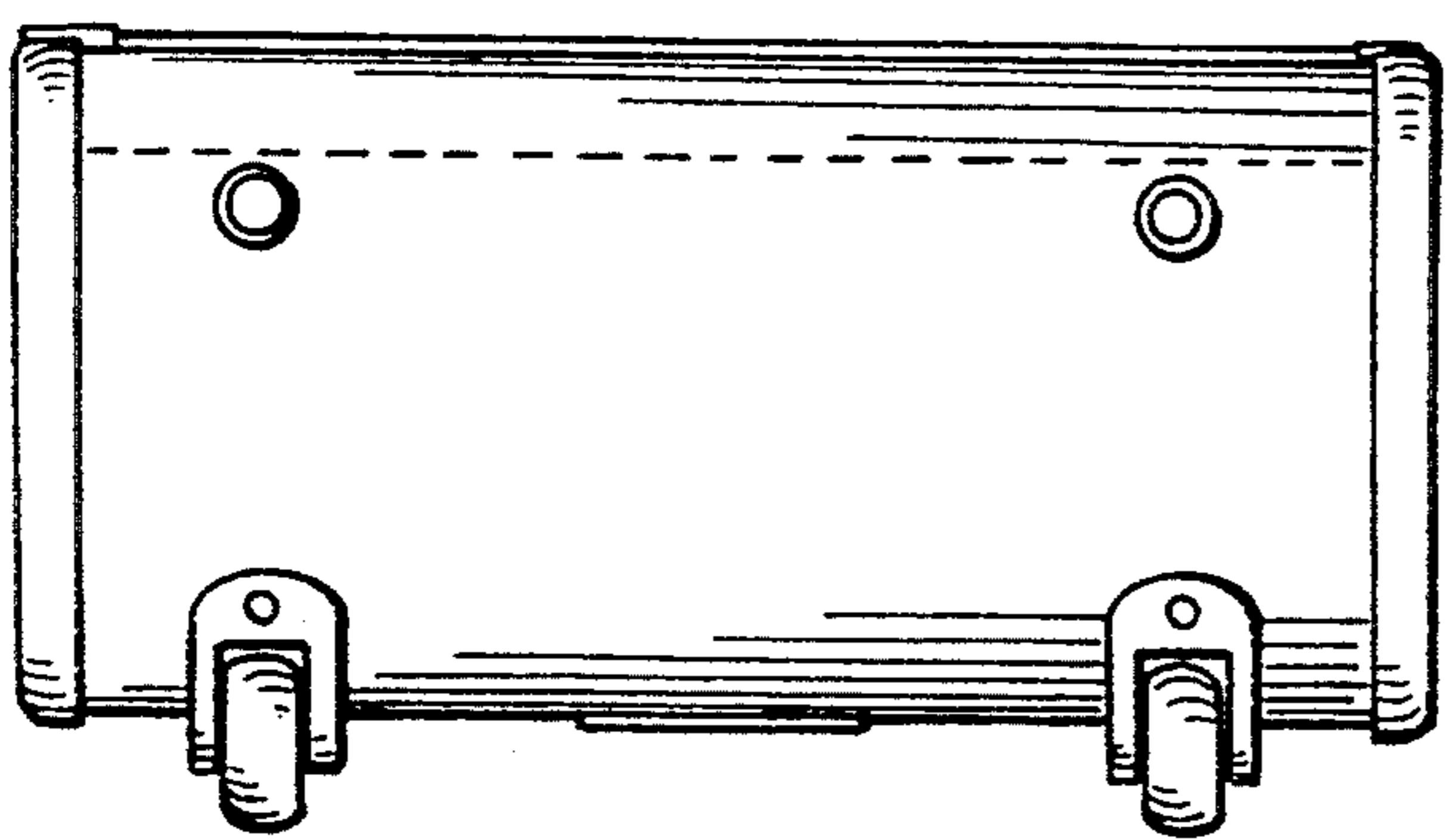

Fig. 6

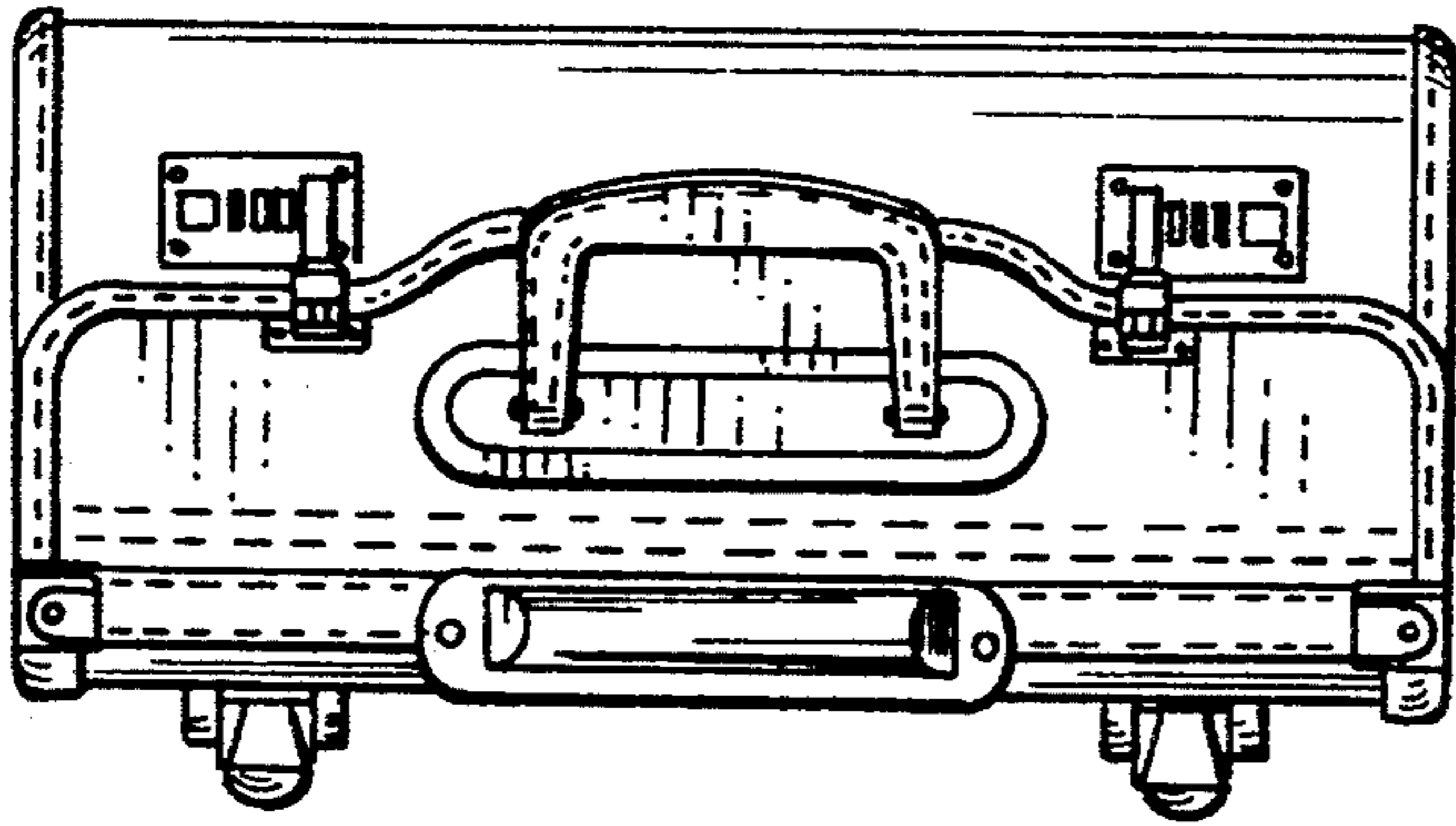

Fig. 7

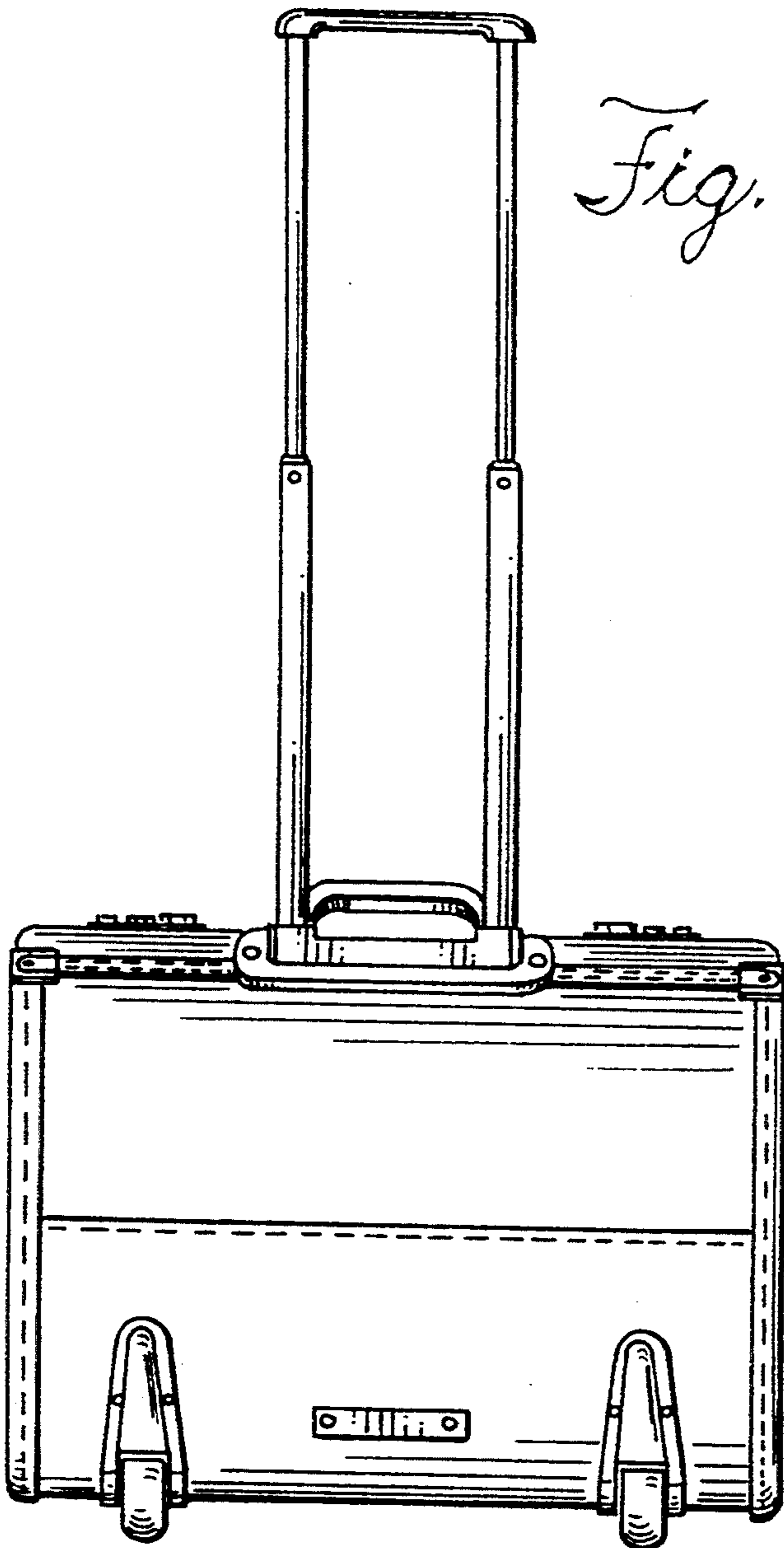

Fig. 8

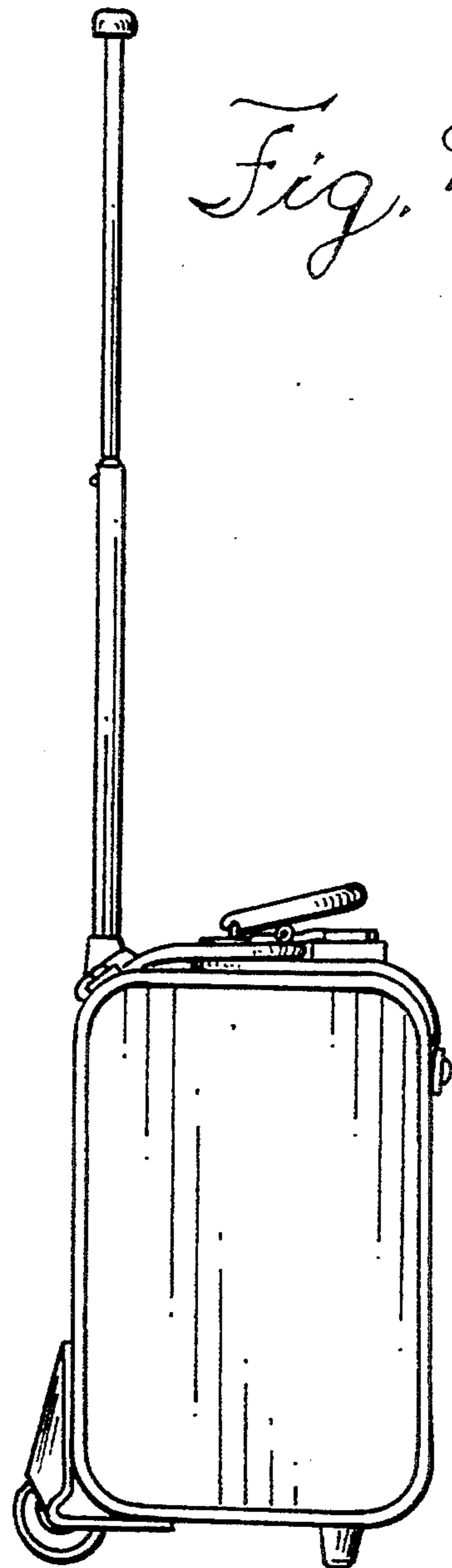

Fig. 9