



US00D357271S

United States Patent [19]

[11] Patent Number: **Des. 357,271**

Hoshina

[45] Date of Patent: **** Apr. 11, 1995**

[54] ELECTRONIC PERCUSSION INSTRUMENT

[75] Inventor: **Yasuhiro Hoshina**, Hamamatsu, Japan

[73] Assignee: **Yamaha Corporation**, Shizuoka, Japan

[**] Term: **14 Years**

[21] Appl. No.: **4,819**

[22] Filed: **Feb. 16, 1993**

[30] Foreign Application Priority Data

Aug. 28, 1992 [JP] Japan 4-25578

[52] U.S. Cl. **D17/22**

[58] Field of Search **D17/22, 99; D21/64; 84/723-733, 411 R, 411 P, DIG. 12, DIG. 14, DIG. 24; 446/408**

[56] References Cited

U.S. PATENT DOCUMENTS

D. 316,422	4/1991	Mine	D17/22
D. 328,915	8/1992	Sato	D17/22
3,113,480	12/1963	Giarratano	84/422.1
4,479,412	10/1984	Klynas	84/730

FOREIGN PATENT DOCUMENTS

2-192000 7/1990 Japan 84/DIG. 12

OTHER PUBLICATIONS

Hong Kong Enterprise, Mar. 1989 p. 245 (Electronic Drum, Item 8502).

Primary Examiner—Bernard Ansher
Assistant Examiner—Adir Aronovich
Attorney, Agent, or Firm—Weingarten, Schurgin, Gagnebin & Hayes

[57] CLAIM

The ornamental design for electronic percussion instrument, as shown.

DESCRIPTION

FIG. 1 is a top, front perspective view of an electronic percussion instrument showing my new design;
FIG. 2 is a front view thereof;
FIG. 3 is a rear view thereof;
FIG. 4 is a right side view thereof;
FIG. 5 is a left side view thereof;
FIG. 6 is a top plan view thereof; and,
FIG. 7 is a bottom plan view thereof.

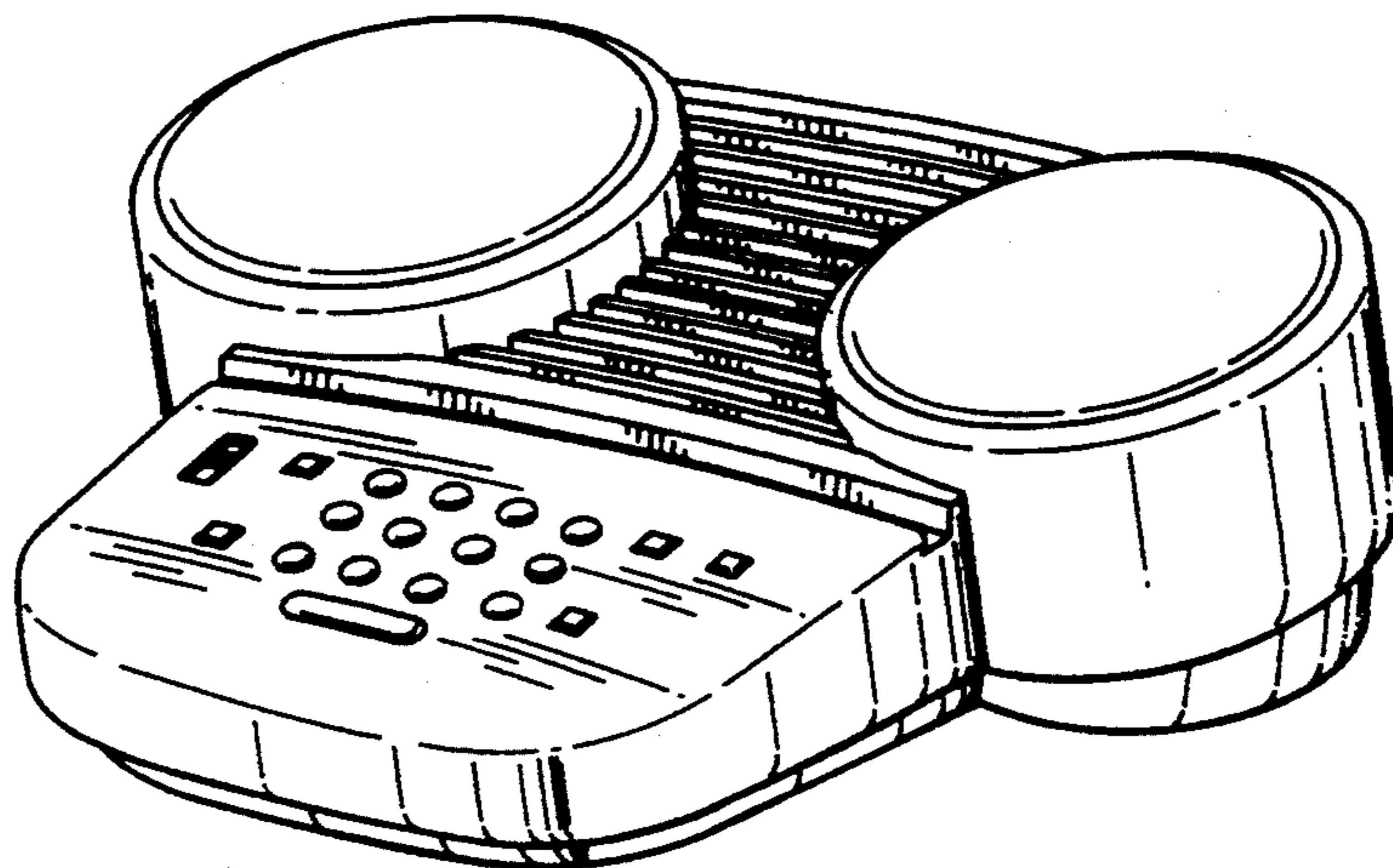

FIG. 1

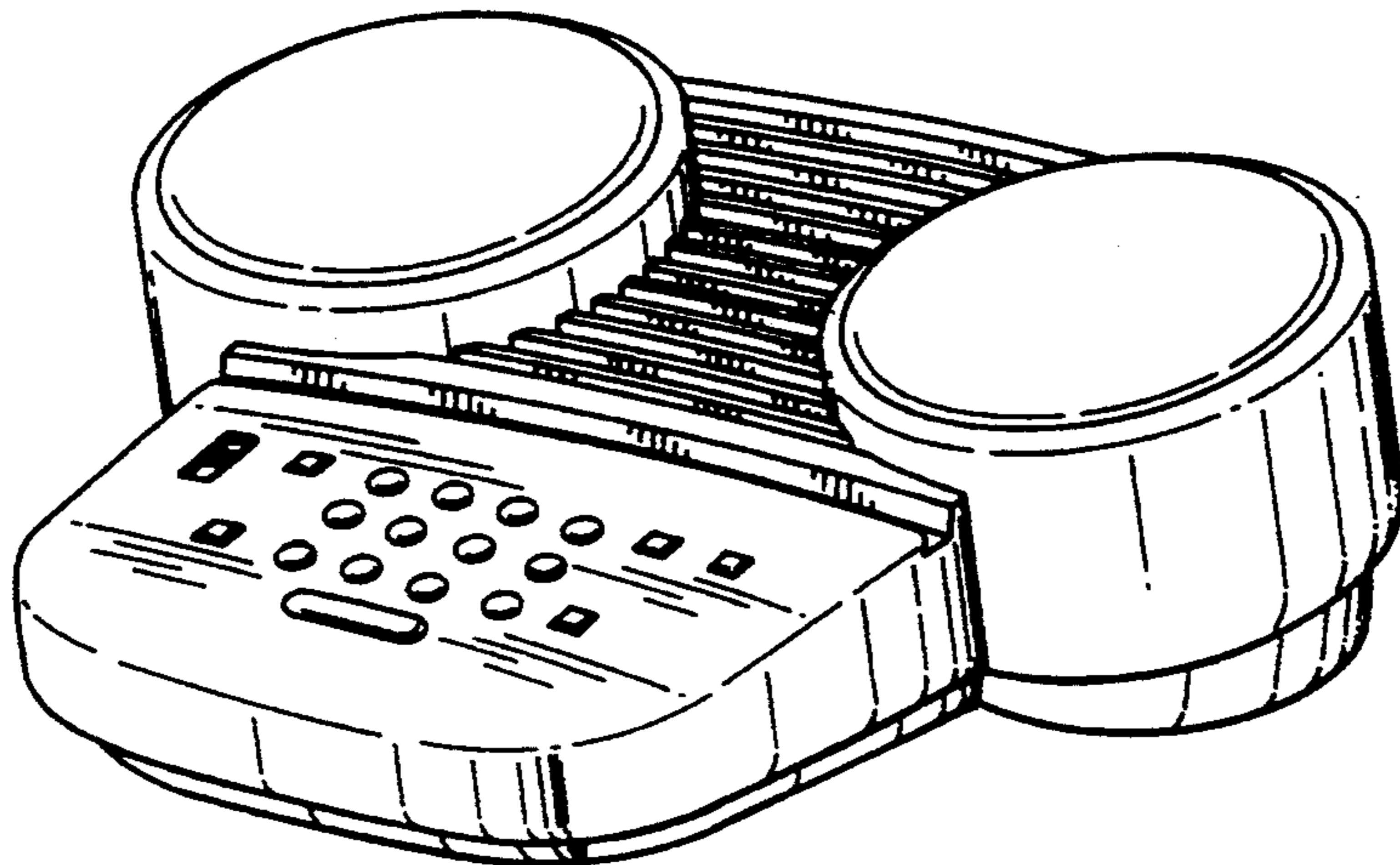

FIG. 2

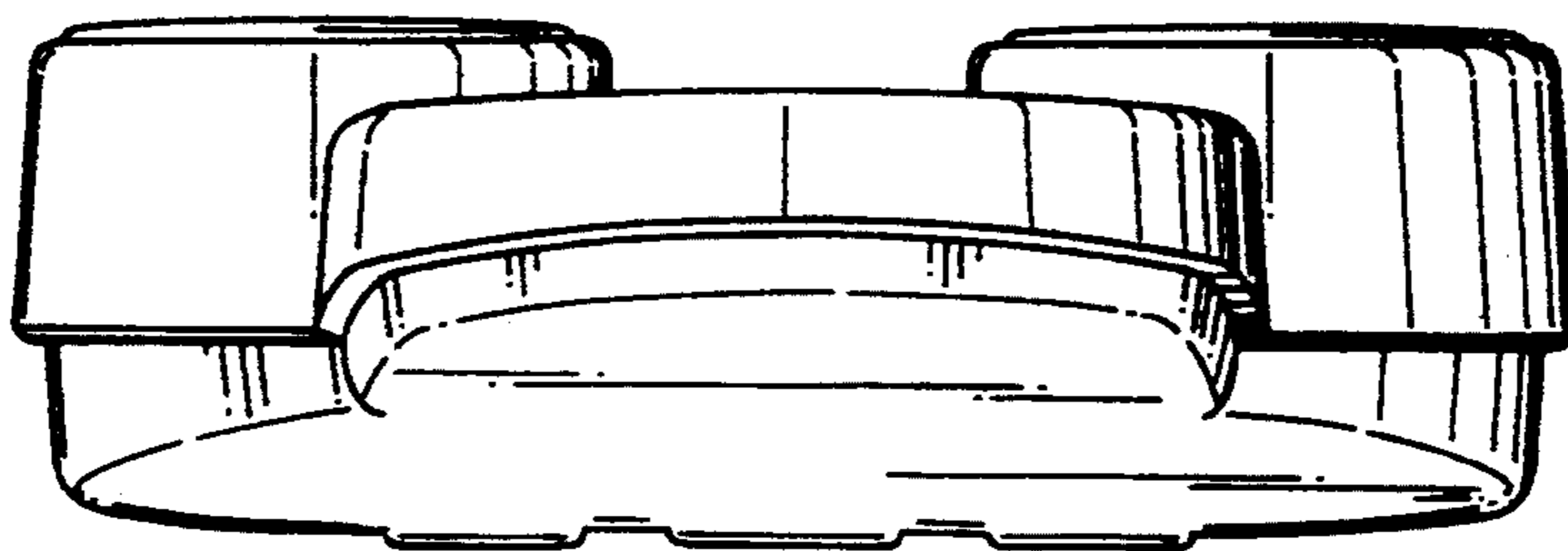

FIG. 3

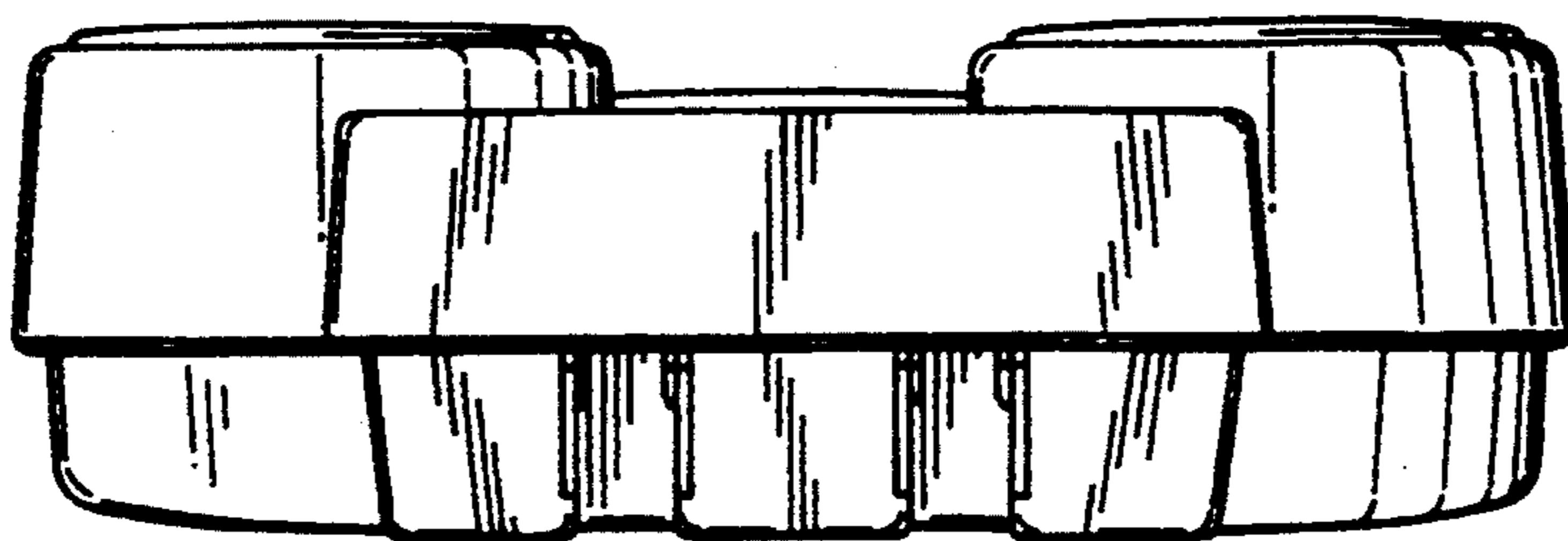

FIG.4

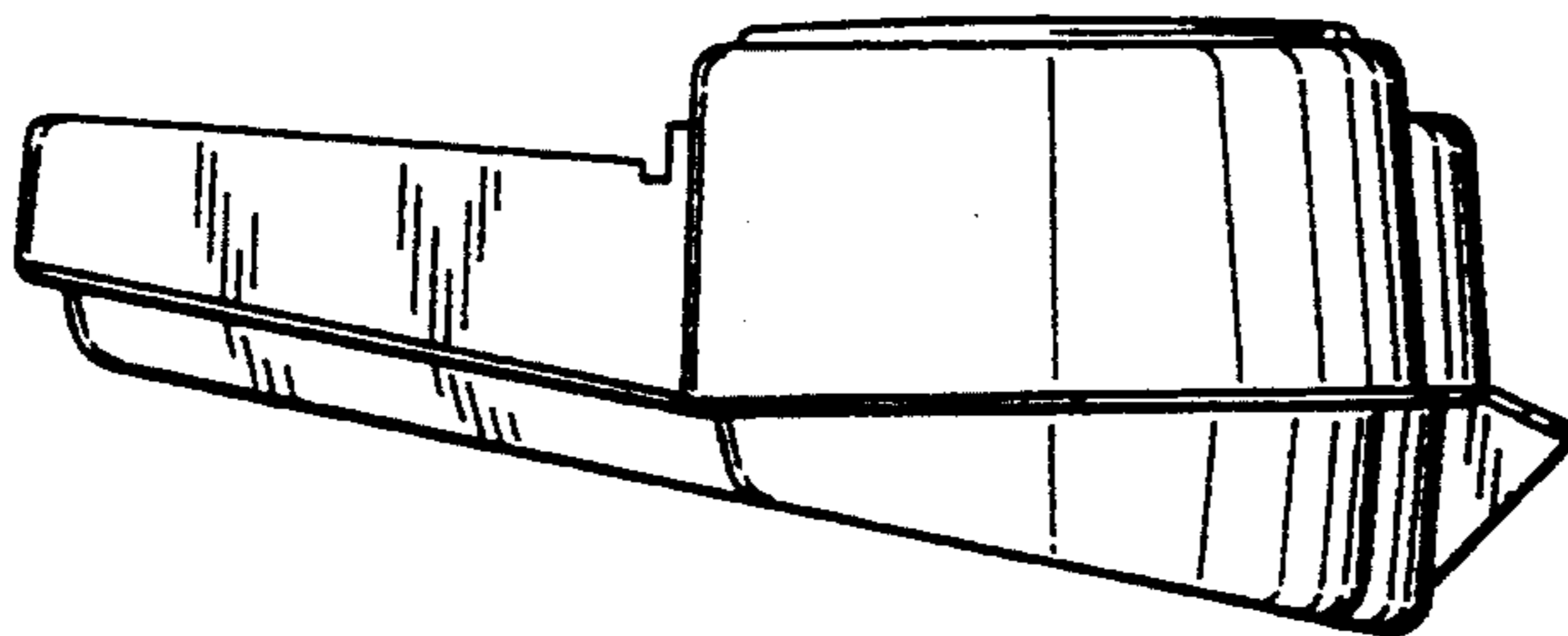

FIG.5

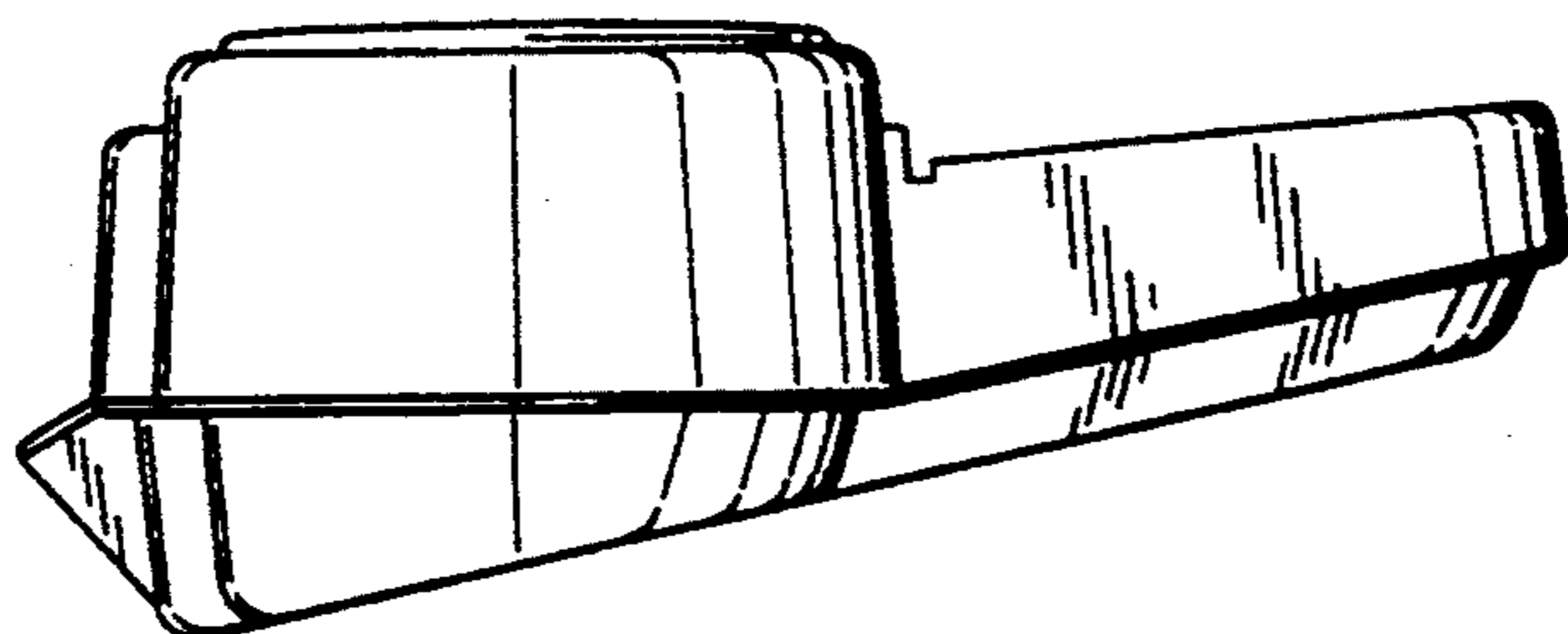

FIG.6

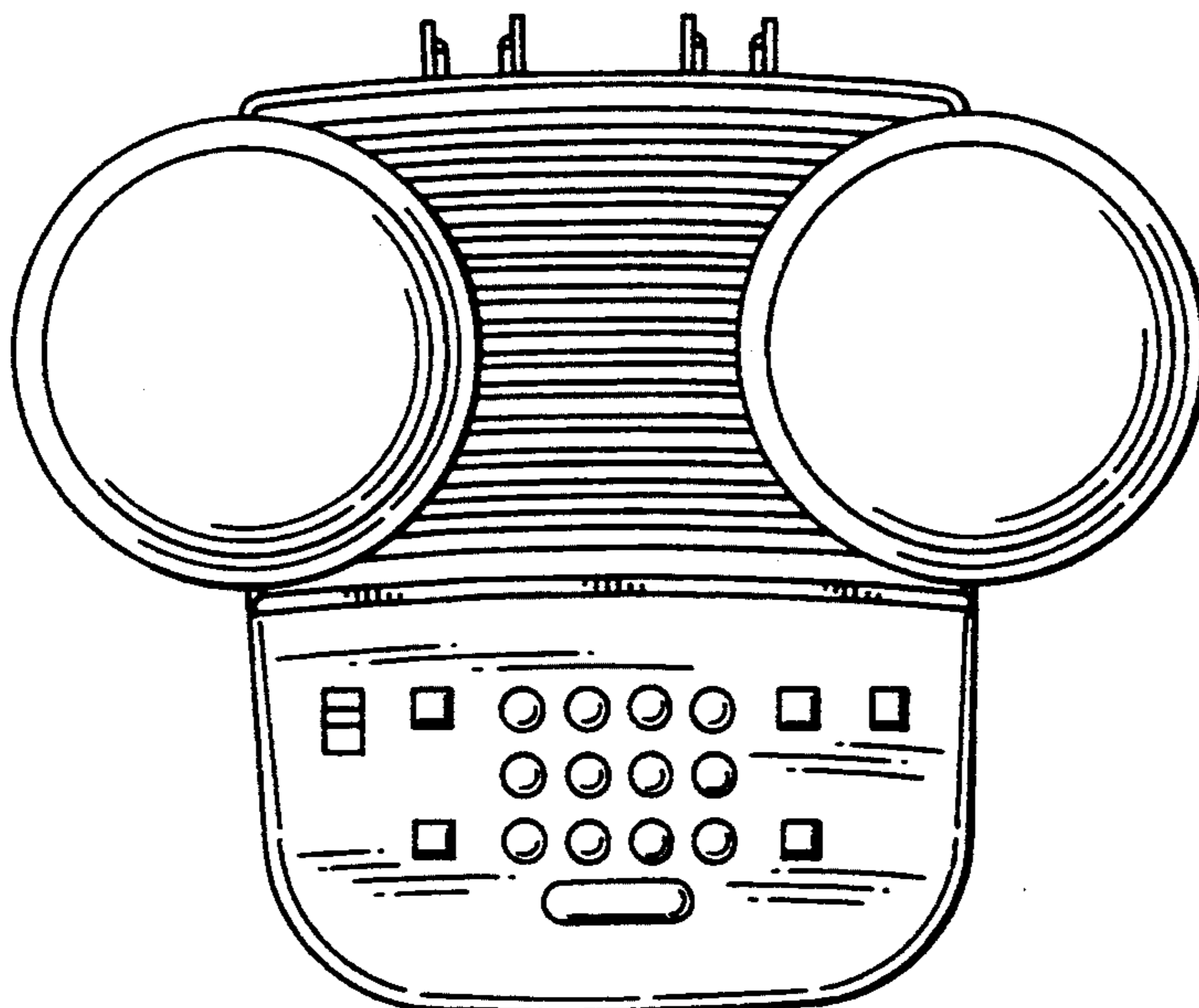

FIG. 7

