



US00D357105S

# United States Patent [19]

[11] Patent Number: **Des. 357,105**

Reiland et al.

[45] Date of Patent: **\*\* Apr. 4, 1995**

[54] **CHILD CARRIER ATTACHABLE TO A SHOPPING OR LUGGAGE CART**

FOREIGN PATENT DOCUMENTS

[75] Inventors: **Mary J. Reiland**, Apple Valley;  
**Kenneth H. Reiland**, Burnsville, both of Minn.

2025860 1/1980 United Kingdom ..... 280/33.992

[73] Assignee: **Four D Incorporated**, Burnsville, Minn.

*Primary Examiner*—Kay H. Chin  
*Attorney, Agent, or Firm*—Schwegman, Lundberg & Woessner

[\*\*] Term: **14 Years**

[57] **CLAIM**

[21] Appl. No.: **23,609**

The ornamental design for a child carrier attachable to a shopping or luggage cart, as shown and described.

[22] Filed: **May 27, 1994**

**DESCRIPTION**

[52] U.S. Cl. .... **D34/27; D34/26**

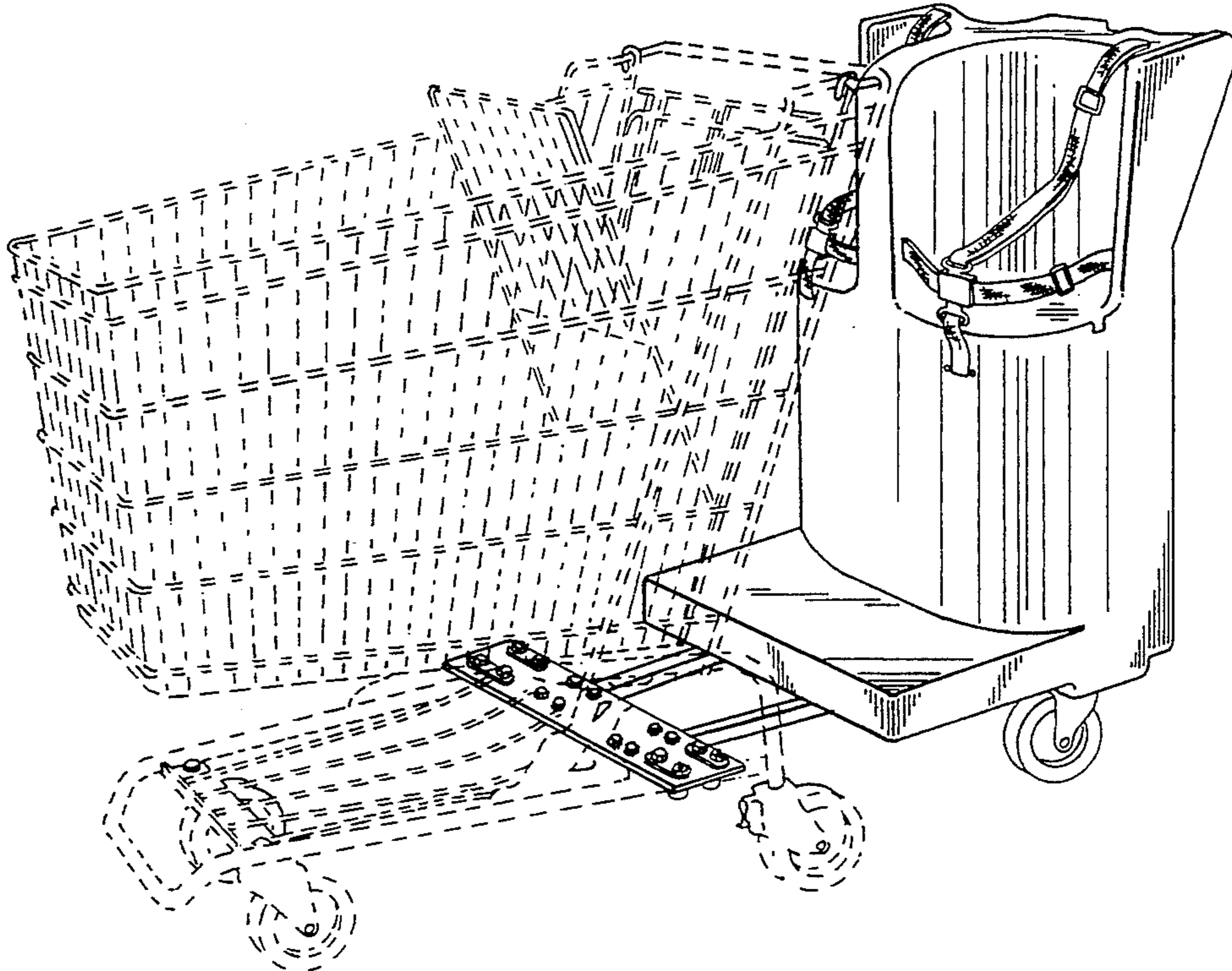
[58] Field of Search ..... **D34/12, 24, 25, 26, D34/27, 20, 5; 280/655, 654, 47.29, 47.26, 33.991, 33.992, 33.993, 79.3**

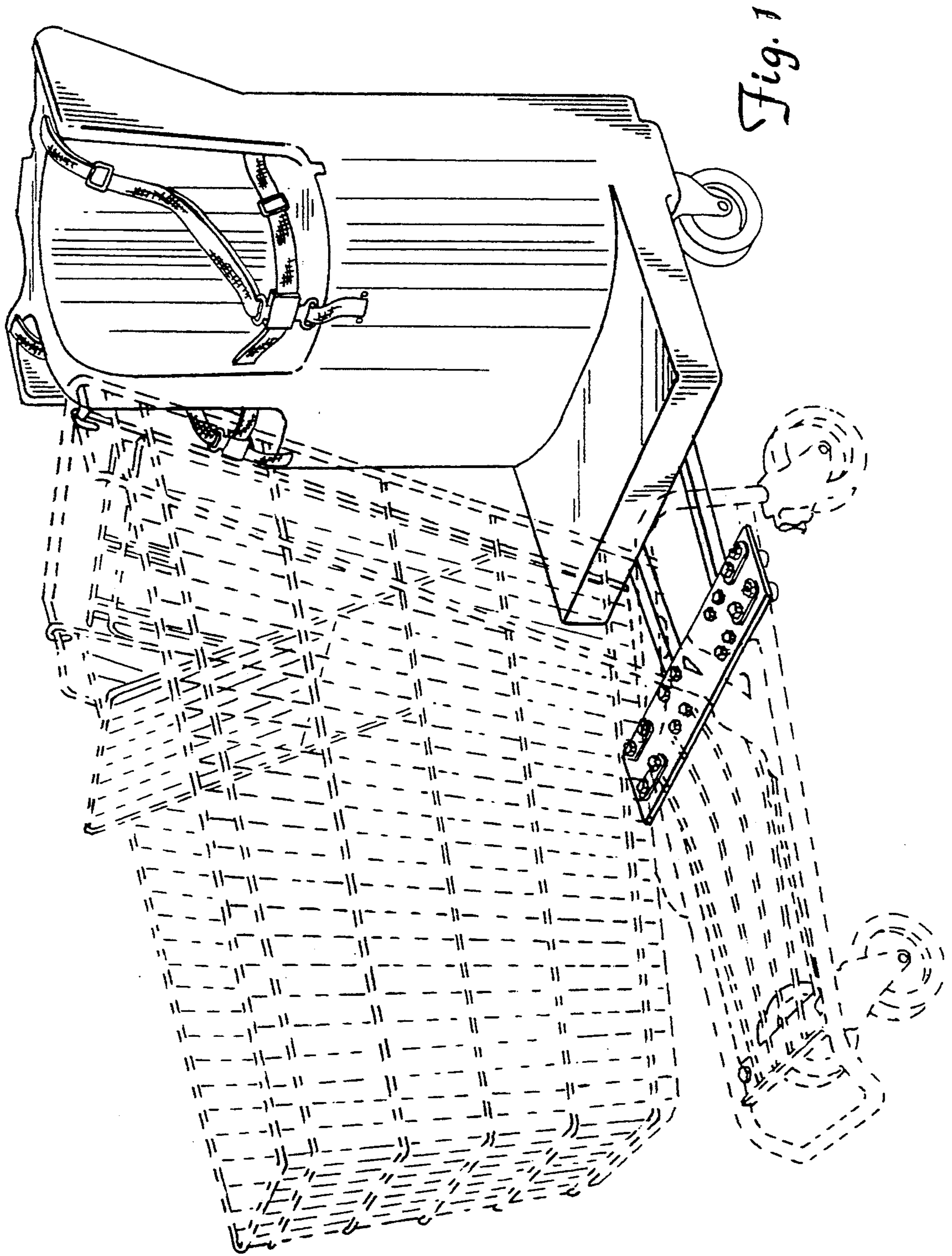
FIG. 1 is a front perspective view of a child carrier attachment to a shopping or luggage cart showing my new design, the broken lines are for illustrative purposes only and form no part of the claimed design; FIG. 2 is a top plan view of thereof; FIG. 3 is a front elevational view thereof; FIG. 4 is a side elevational view thereof, the opposite side view being identical; FIG. 5 is a rear elevational view thereof; FIG. 6 is a bottom plan view thereof; FIG. 7 is a front perspective view of a second embodiment of the child carrier attachment to a shopping or luggage cart; FIG. 8 is a top plan view of FIG. 7; FIG. 9 is a front elevational view of FIG. 7; FIG. 10 is a side elevational view of FIG. 7, the opposite side view being identical; FIG. 11 is a rear elevational view of FIG. 7; FIG. 12 is a bottom plan view of FIG. 7; and, FIG. 13 is a front perspective view of FIG. 1 with the luggage cart in phantom.

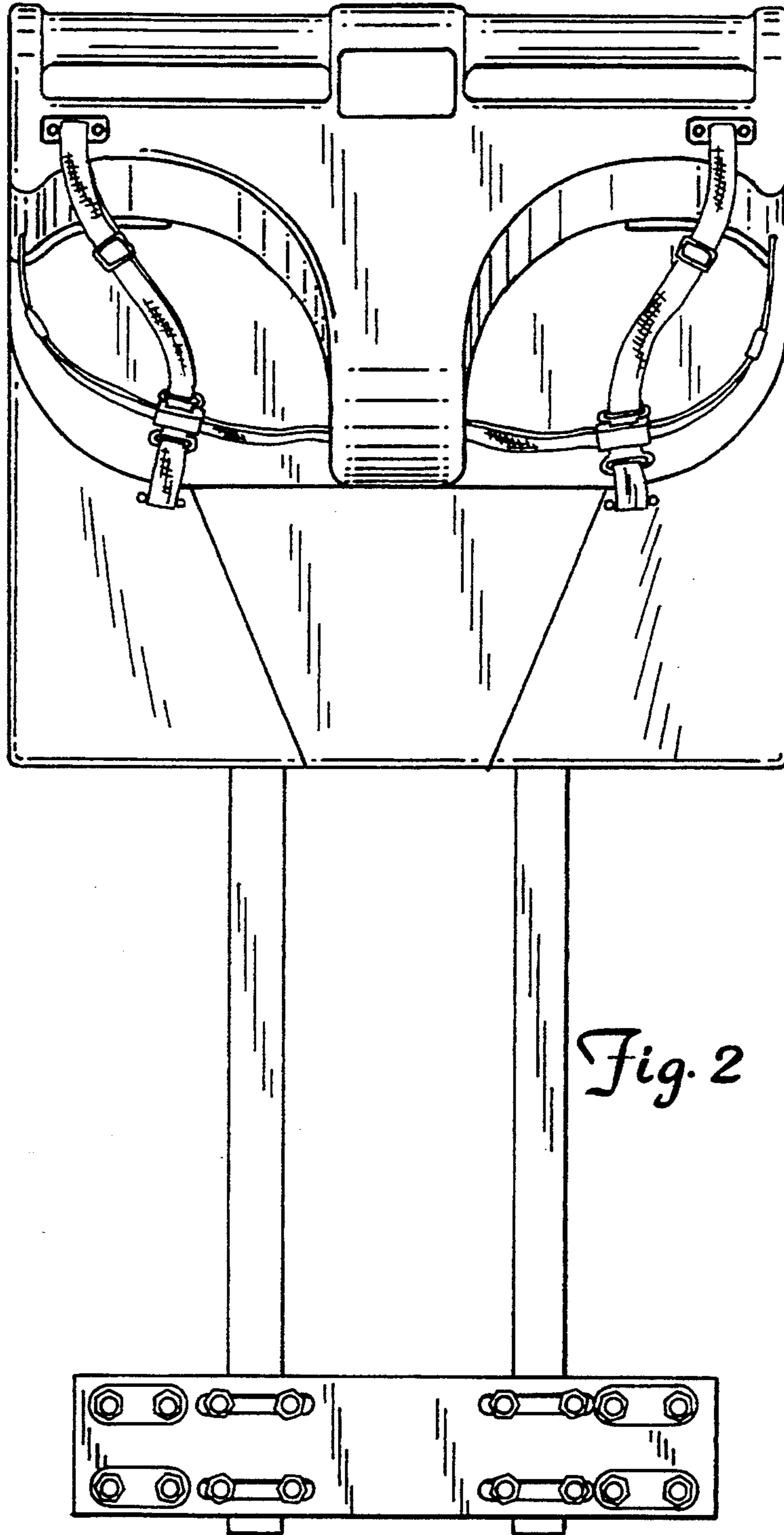
[56] **References Cited**

**U.S. PATENT DOCUMENTS**

D. 281,365	11/1985	Gugler .....	D34/27
D. 330,103	10/1992	Andrews, Jr. et al. ....	D34/20
3,044,801	7/1962	Vicany .	
3,497,234	2/1970	Schray .....	280/33.993
3,575,250	4/1971	Dykes .	
3,834,726	9/1974	Hobza .	
3,953,046	4/1976	Johansson .	
4,610,454	9/1986	Gill .	
4,771,840	9/1988	Keller .	
5,011,169	4/1991	Henderson et al. .	
5,076,599	12/1991	Lockett et al. .	
5,176,395	1/1993	Garforth-Bles .	
5,188,389	2/1993	Baechler et al. .	
5,203,578	4/1993	Davidson et al. ....	280/79.3







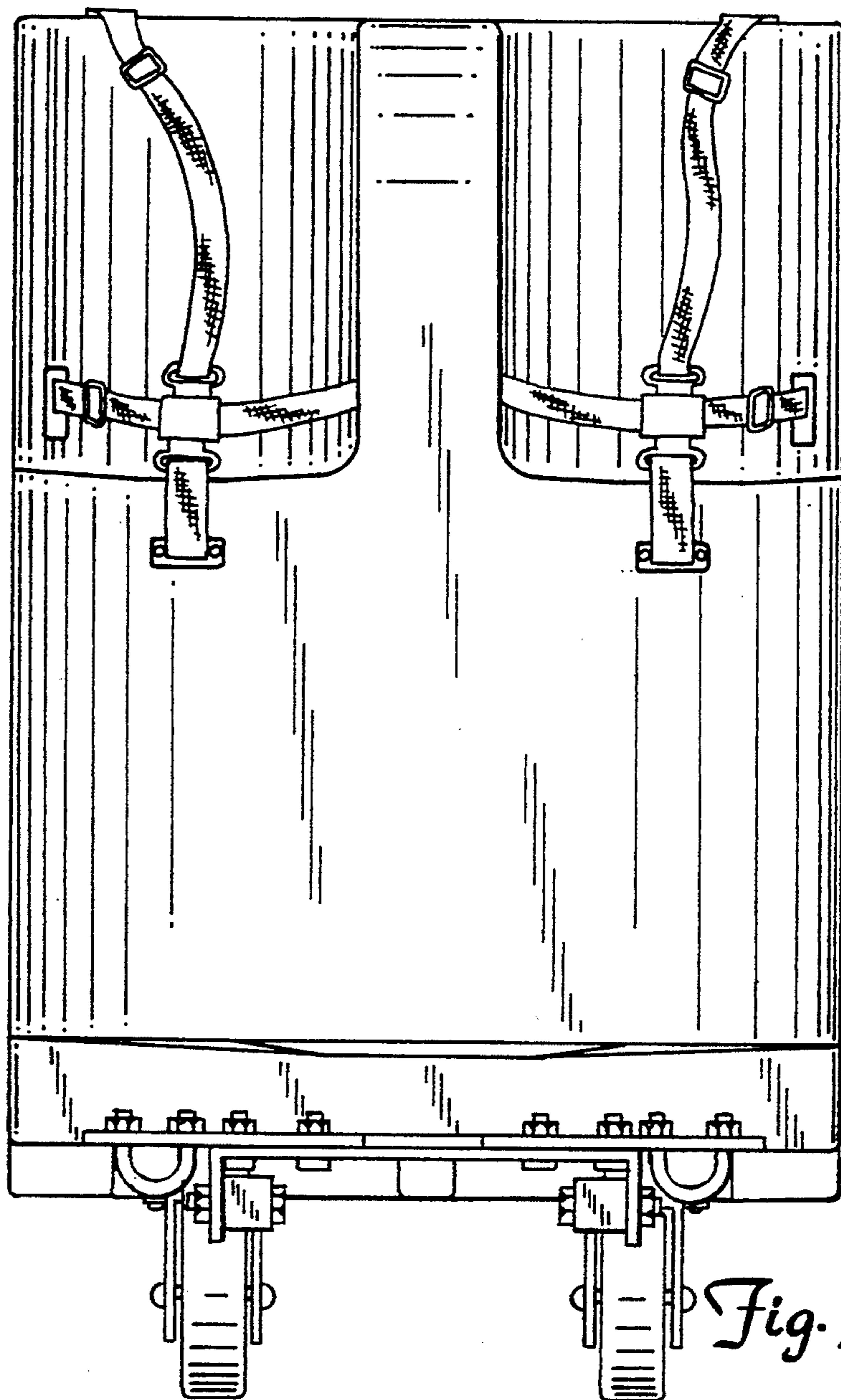
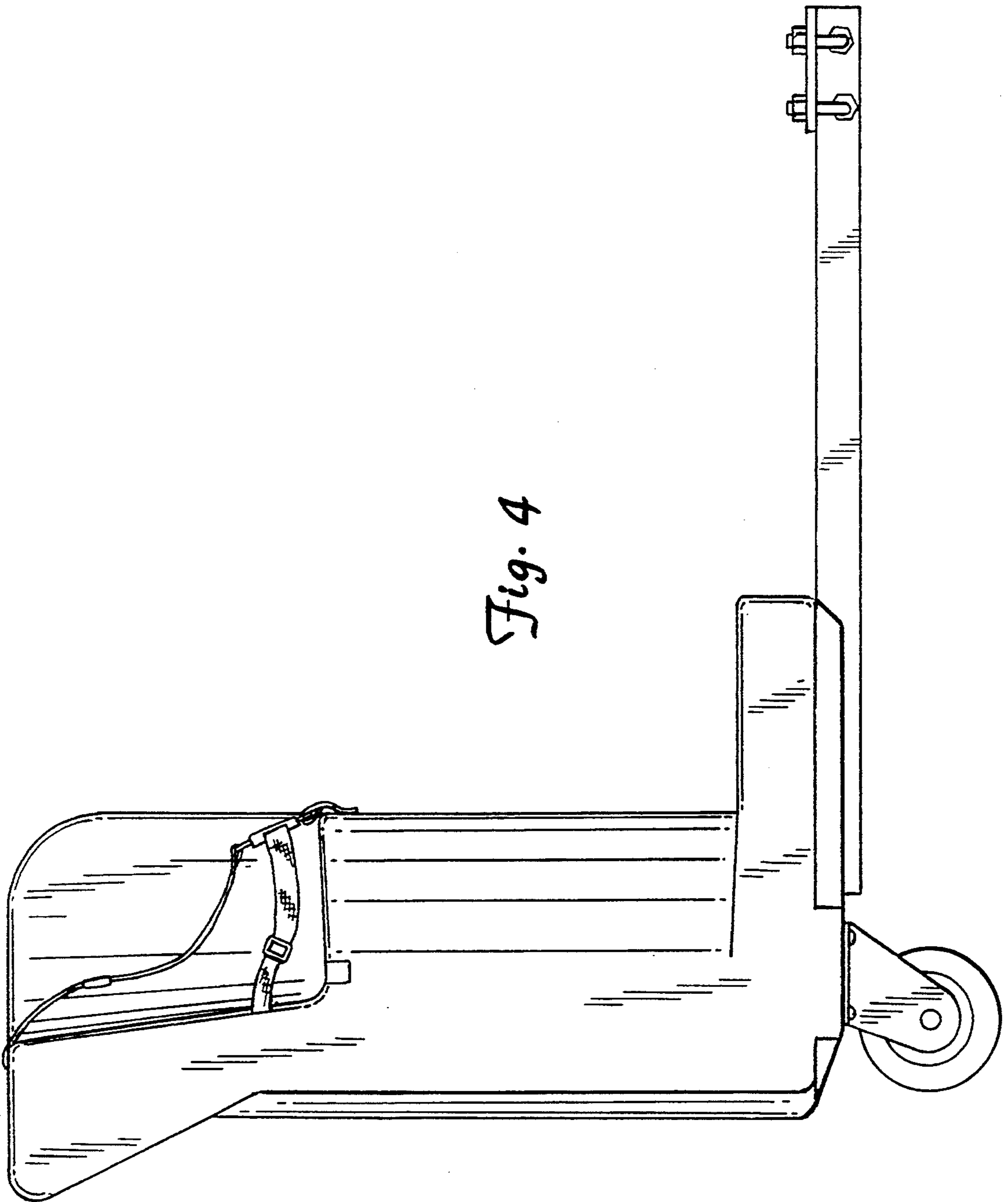
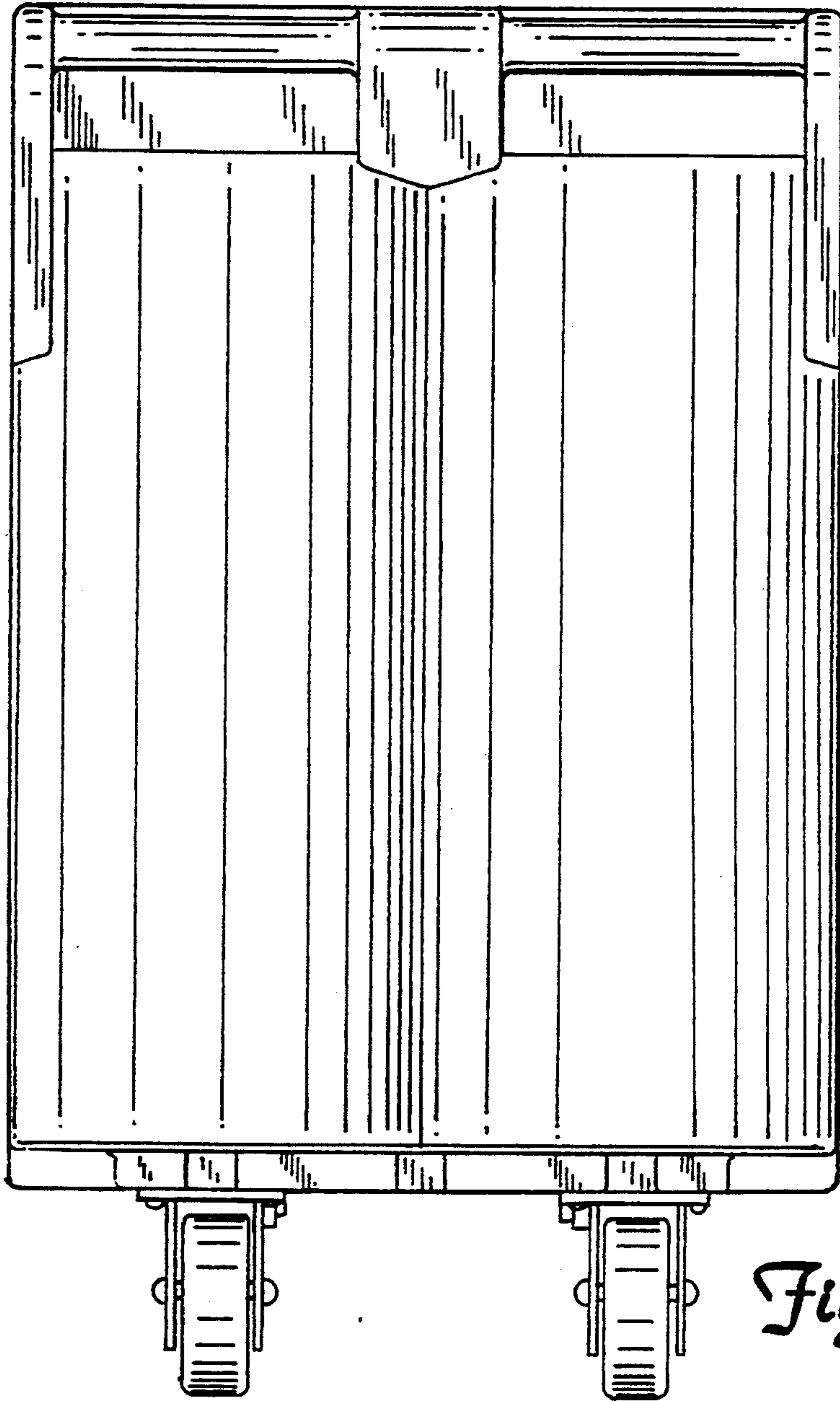


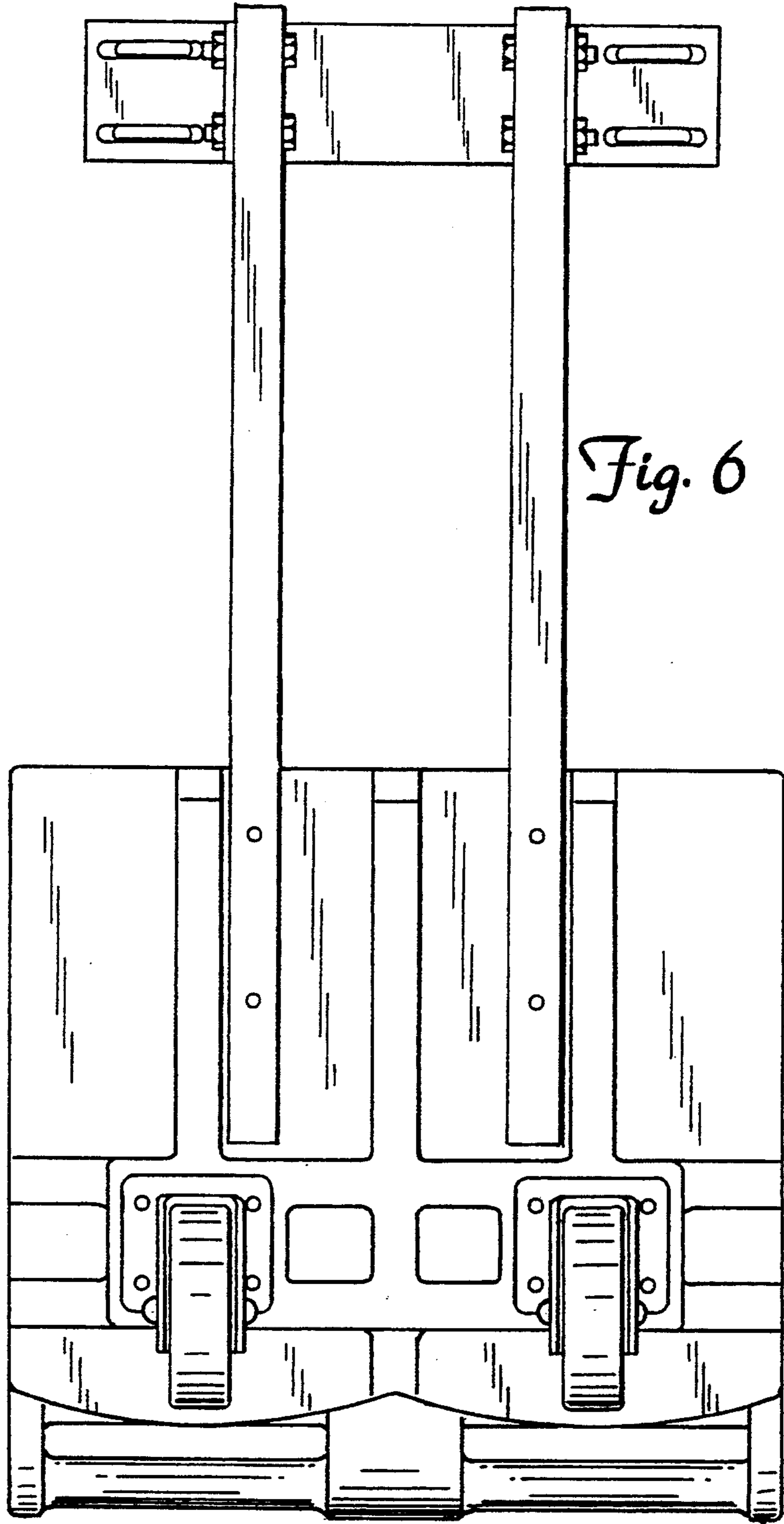
Fig. 3

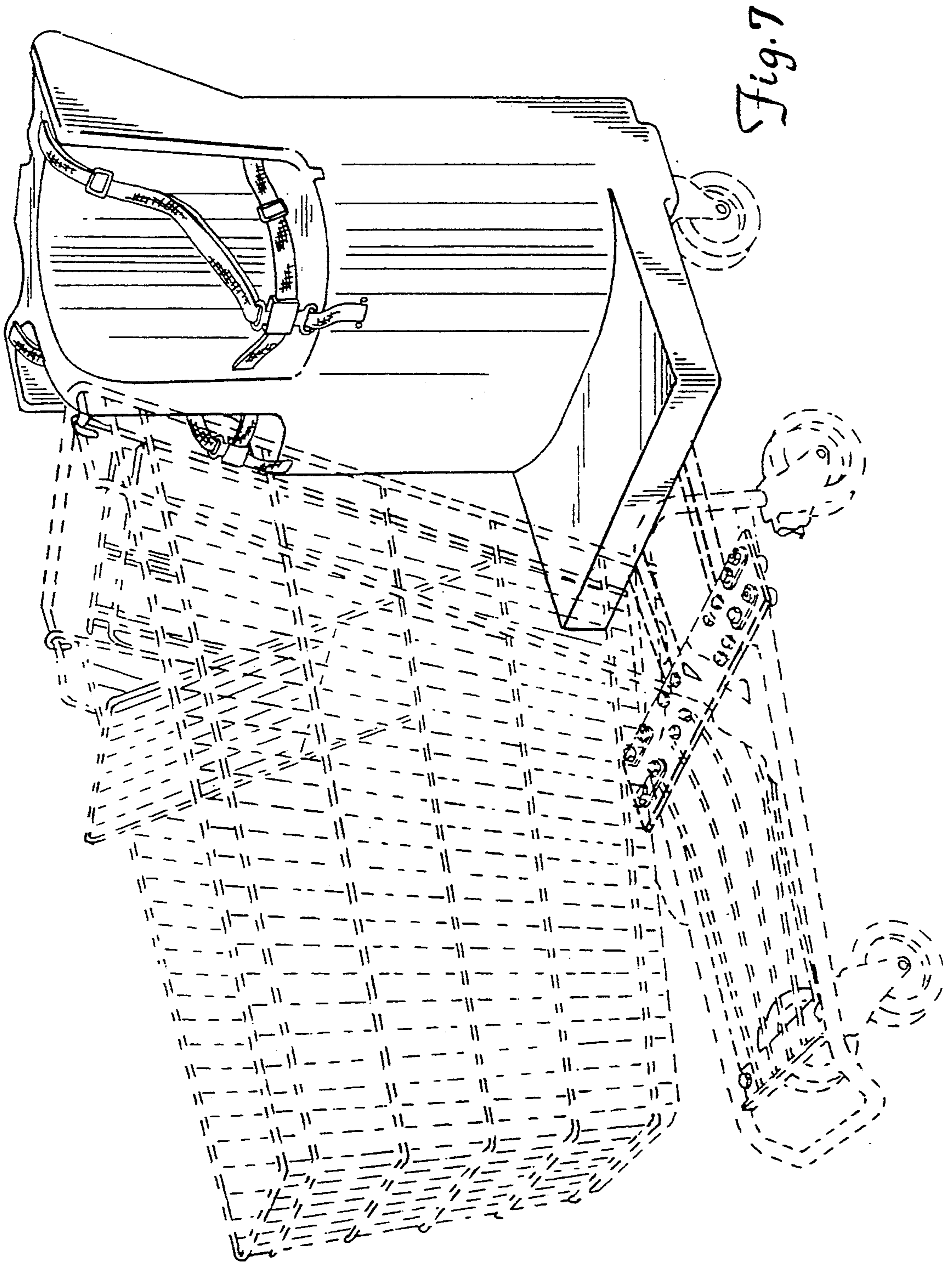


*Fig. 4*

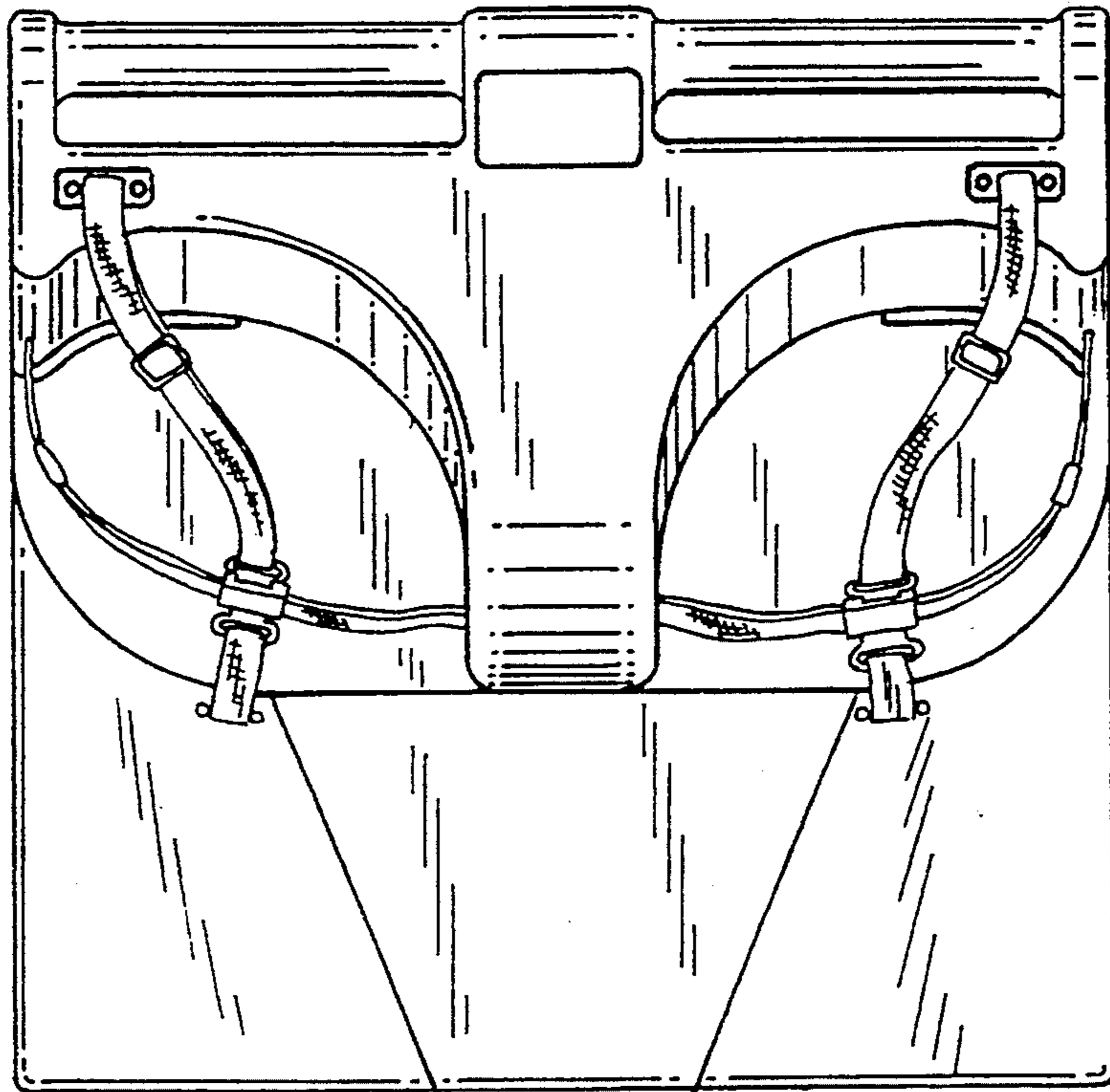


*Fig. 5*









*Fig. 8*

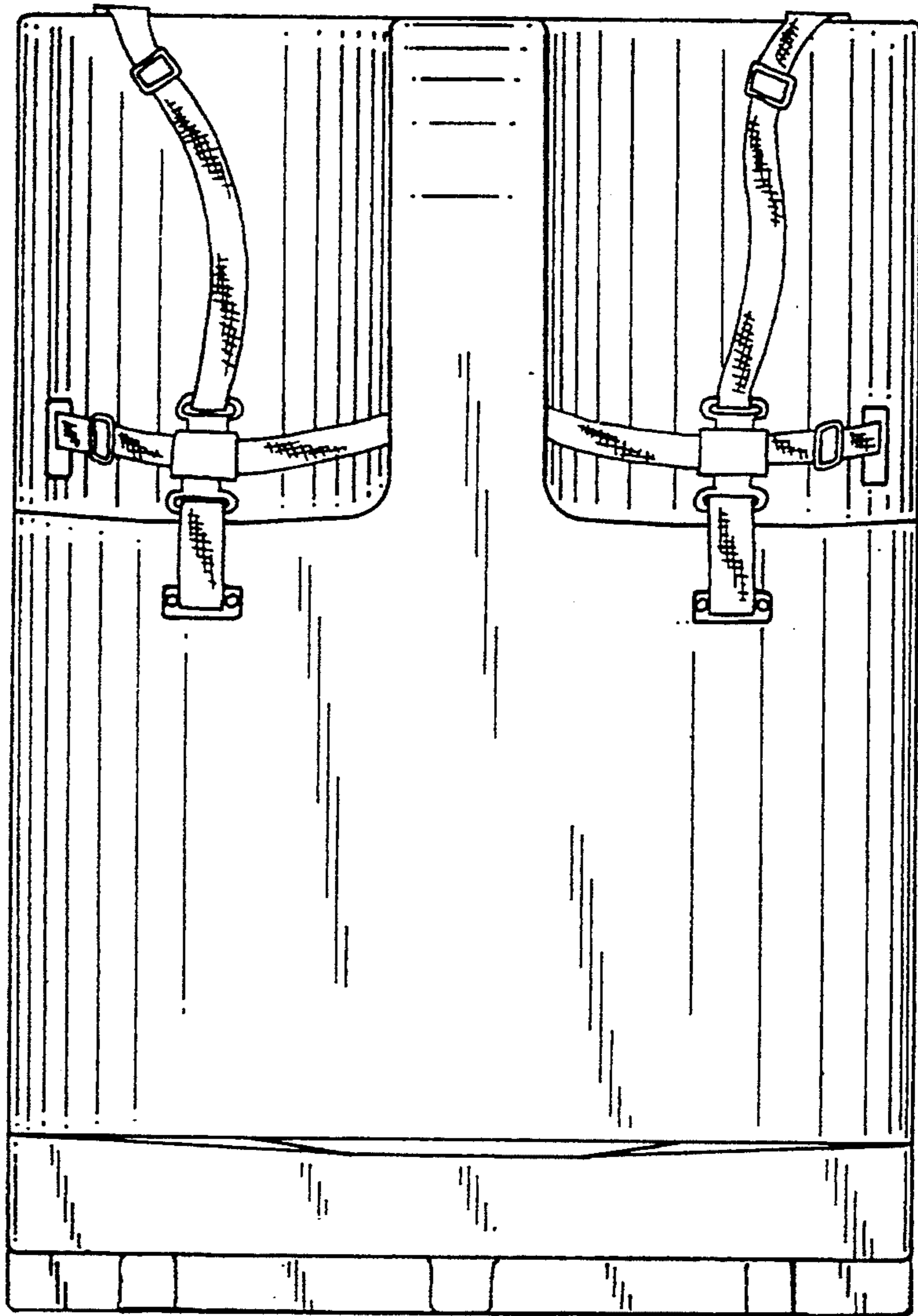
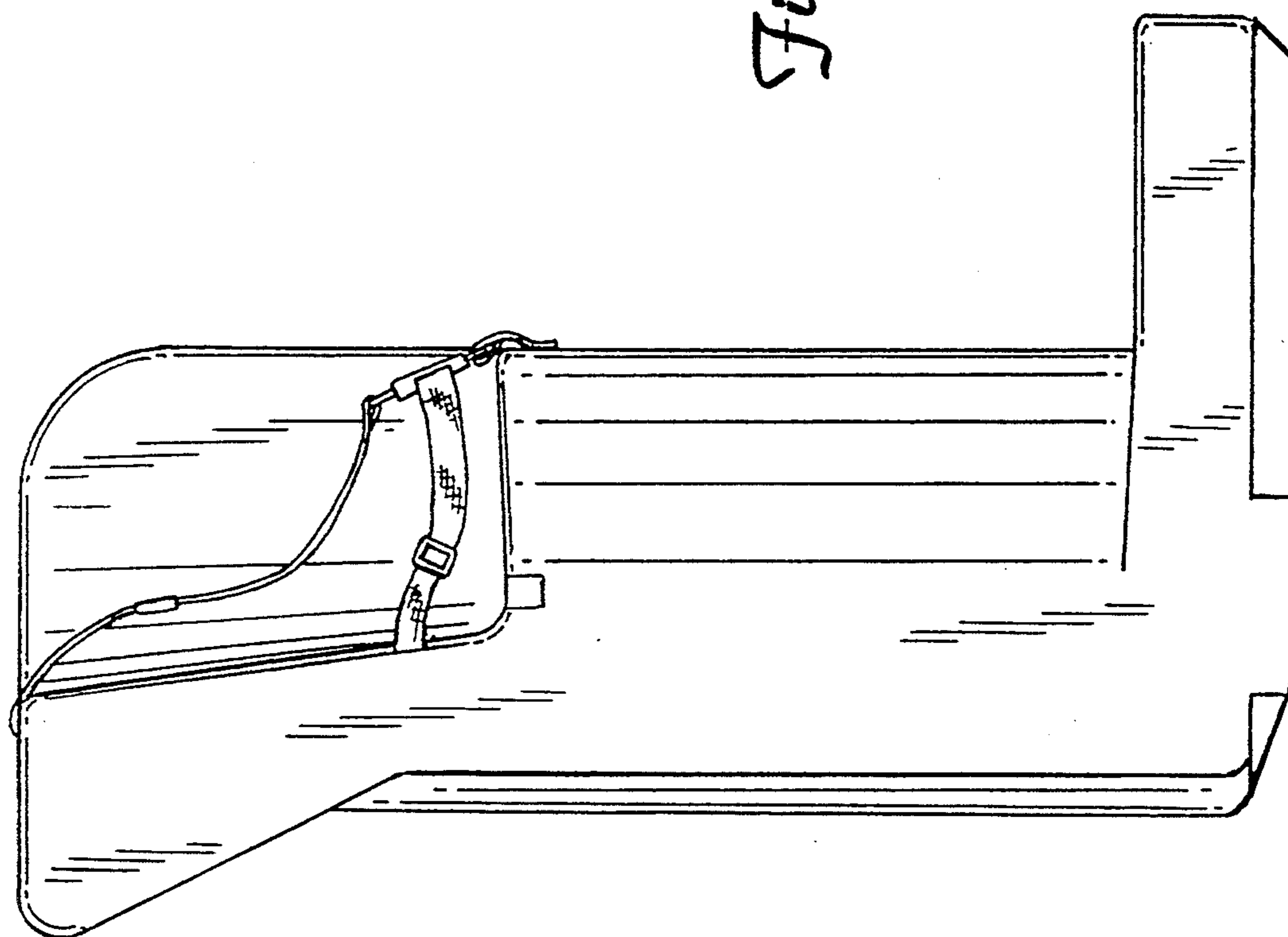
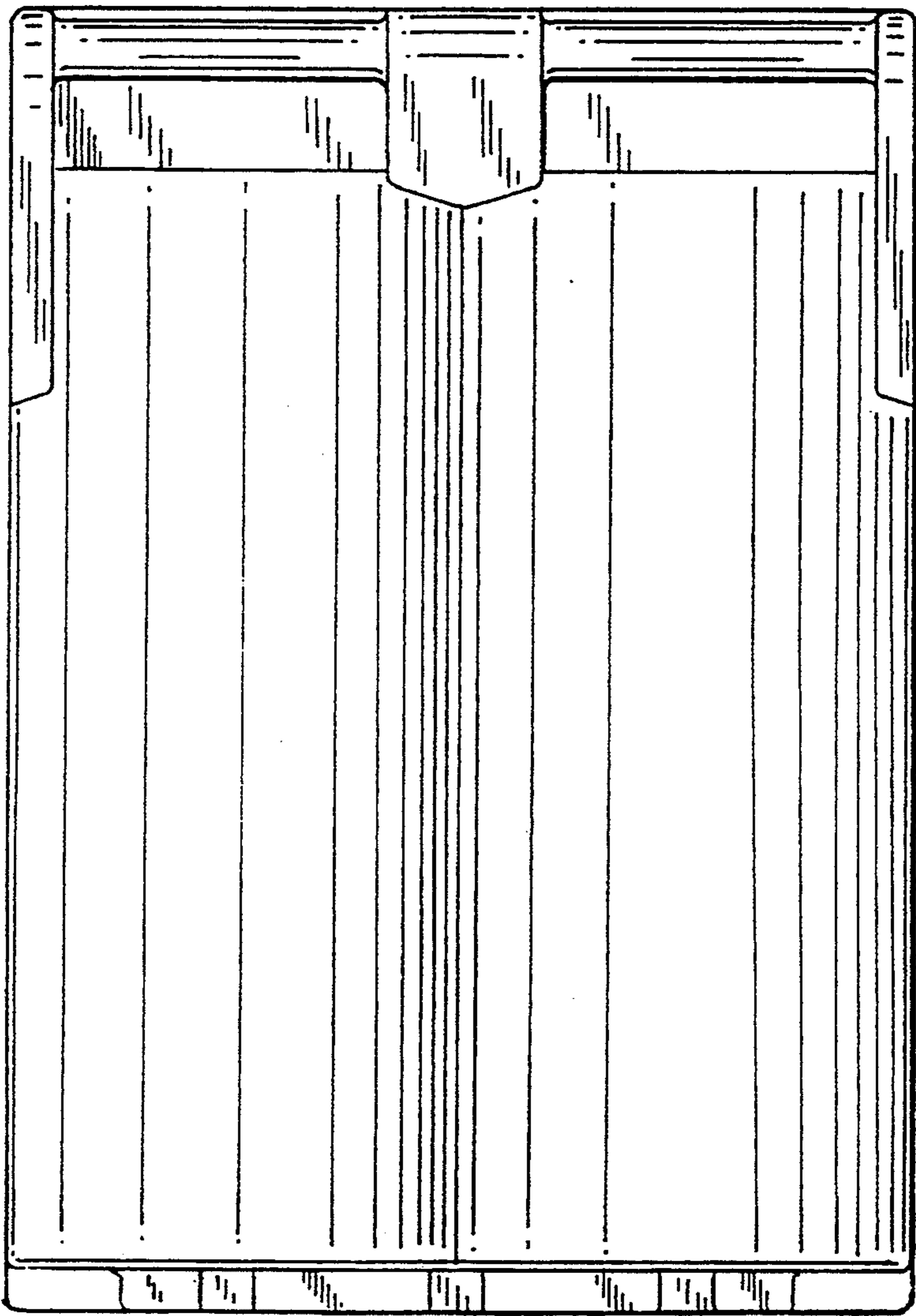


Fig. 9

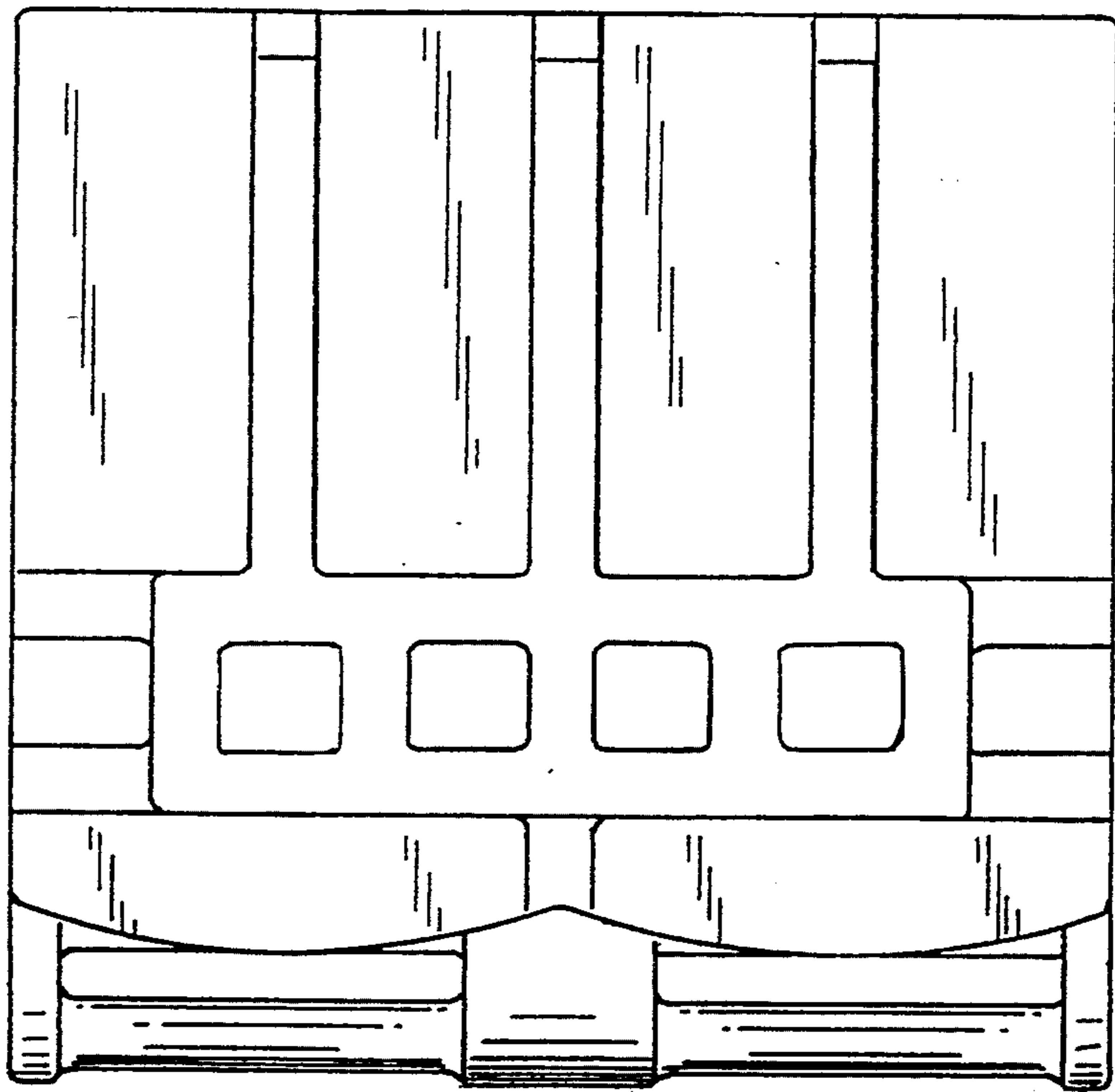
*Fig. 10*





*Fig. 11*

*Fig. 12*



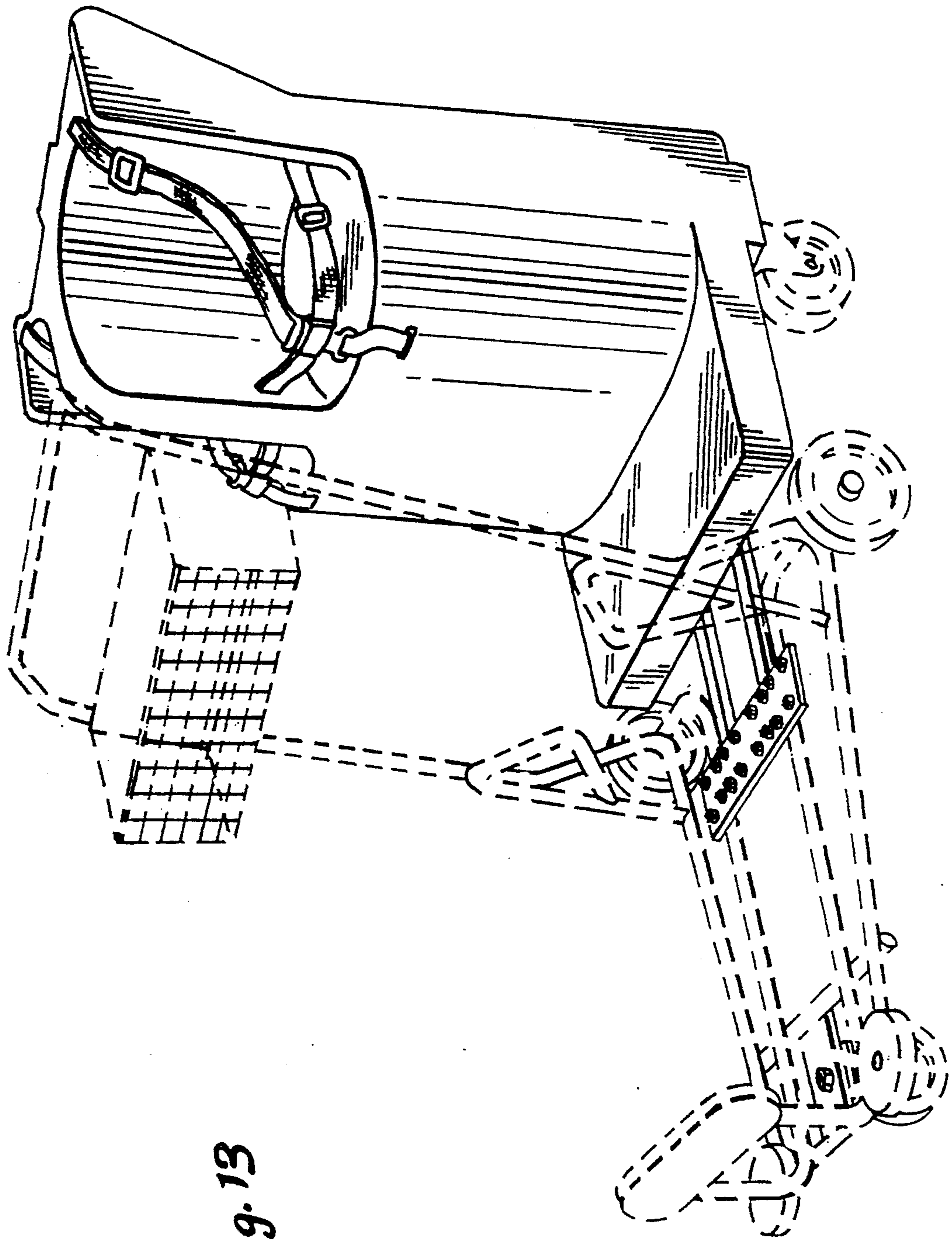


Fig. 13