



US00D356934S

United States Patent [19]

[11] Patent Number: **Des. 356,934**

Lenox

[45] Date of Patent: **** Apr. 4, 1995**

- [54] **BICYCLE TIRE REPAIR TOOL**
- [76] Inventor: **Bruce E. Lenox**, 2820 Atlantic St.,
Concord, Calif. 94518
- [**] Term: **14 Years**
- [21] Appl. No.: **14,830**
- [22] Filed: **Oct. 29, 1993**

1,620,825	3/1927	Mills	81/15.2
1,741,801	12/1929	White	D8/88
1,969,807	8/1934	Leonard	D8/88
2,465,217	3/1949	Fleming	D8/88
3,771,581	11/1973	Johnson	157/1.3
3,957,096	5/1976	Rodman	D8/105
4,304,019	12/1981	Sava	7/170
4,372,362	2/1983	Aha	81/177.4 X
4,712,592	12/1987	Brown	141/98

Related U.S. Application Data

- [63] Continuation-in-part of Ser. No. 664,454, Feb. 28, 1991, abandoned, which is a continuation-in-part of Ser. No. 495,110, Mar. 19, 1990, abandoned.
- [52] U.S. Cl. **D8/88; D8/105; D12/114; D9/549**
- [58] Field of Search **D8/105, 88, 14, 107; D9/549; D3/228; 157/1.3; D12/114; 81/15.2, 490, 177.4; 7/170, 166, 169, 100**

References Cited

U.S. PATENT DOCUMENTS

D. 163,533	6/1951	Mills	D8/88
D. 270,038	8/1983	Lipscombe	D9/549
D. 280,694	9/1985	Drexler	D8/88
D. 338,143	8/1993	Alfano et al.	D8/105
386,055	7/1888	Buzzell	D8/105
1,250,325	12/1917	Langford	81/177.4 X

Primary Examiner—Wallace R. Burke
Assistant Examiner—M. Brown
Attorney, Agent, or Firm—Christopher John Rudy

[57] CLAIM

The ornamental design for a bicycle tire repair tool, as shown and described.

DESCRIPTION

FIG. 1 is a front view of a bicycle tire repair tool showing my new design, having cap and barrel assembled; FIG. 2 is a right hand side view thereof; FIG. 3 is a rear view thereof; FIG. 4 is a left hand side view thereof; FIG. 5 is a perspective view of the tool, exploded; FIG. 6 is a bottom view of the cap with the barrel removed; FIG. 7 is a side view of FIG. 6; and, FIG. 8 is a top view of the barrel with the cap removed.

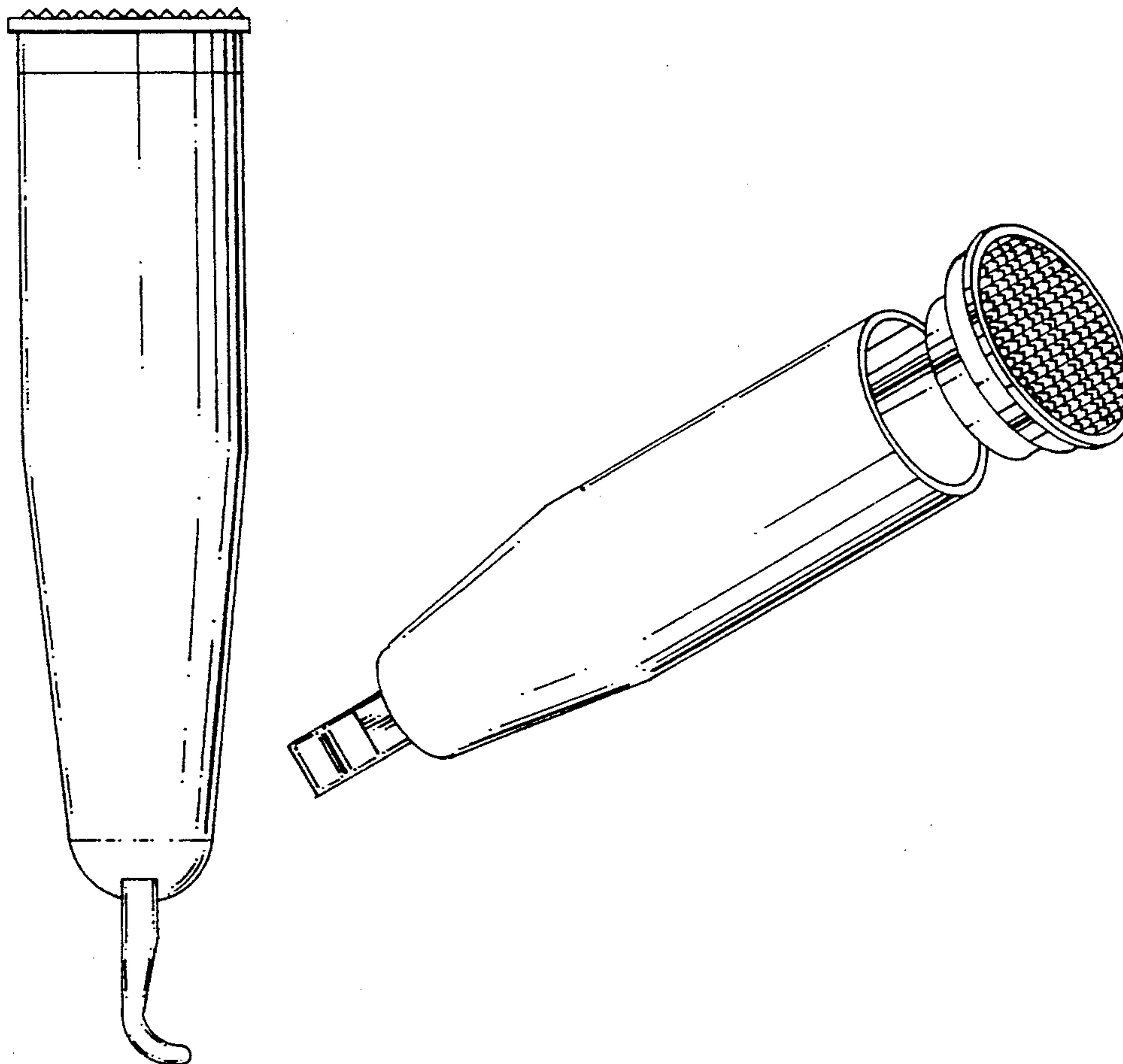

FIG. 1

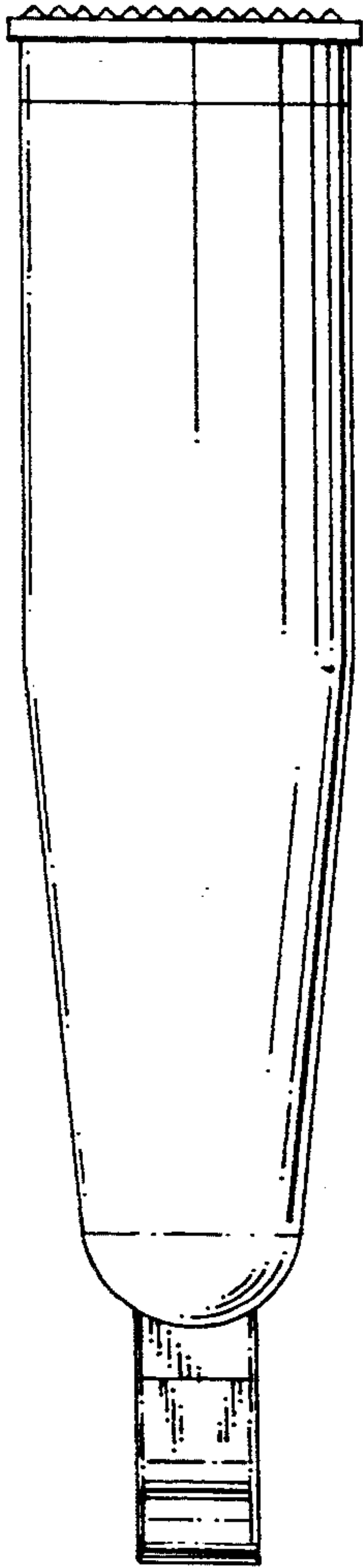

FIG. 2

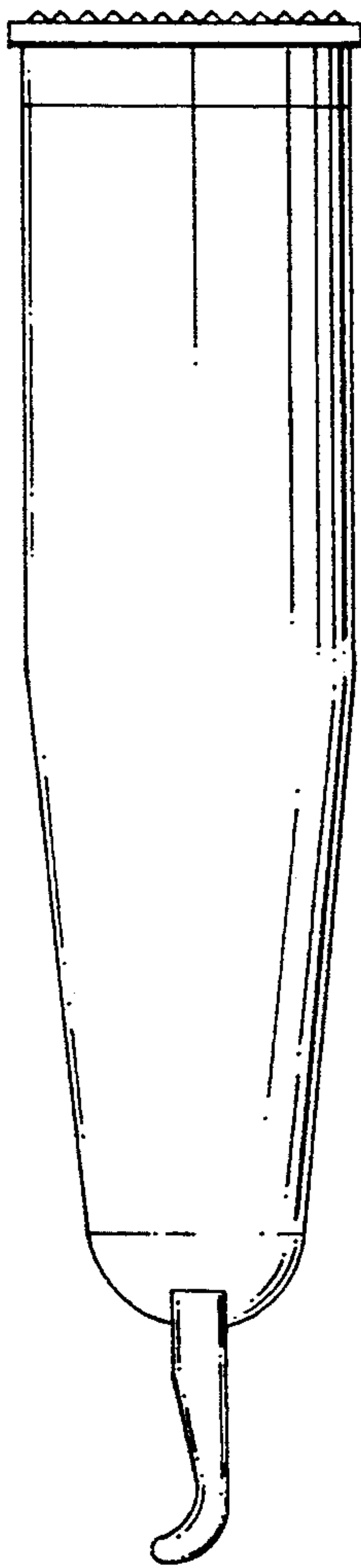

FIG. 3

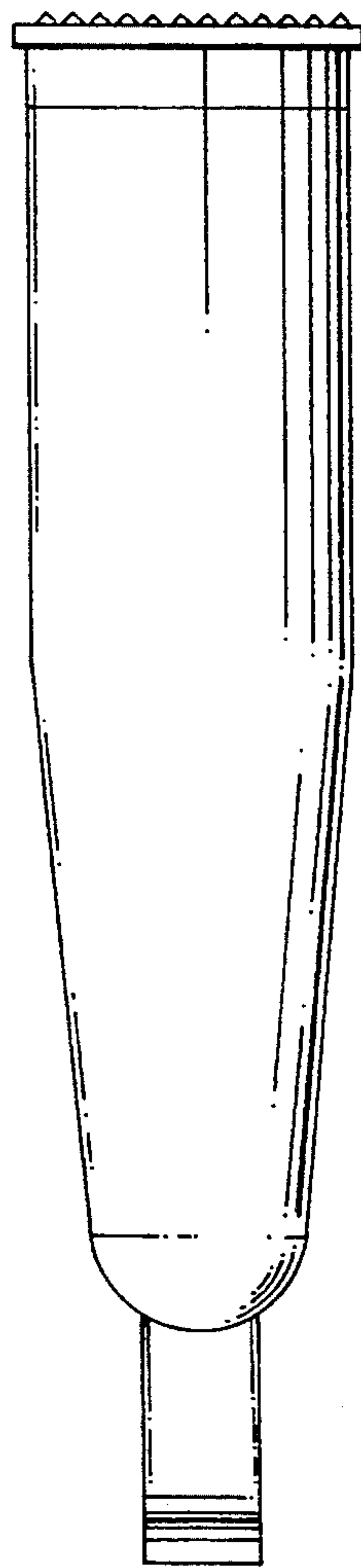

FIG. 4

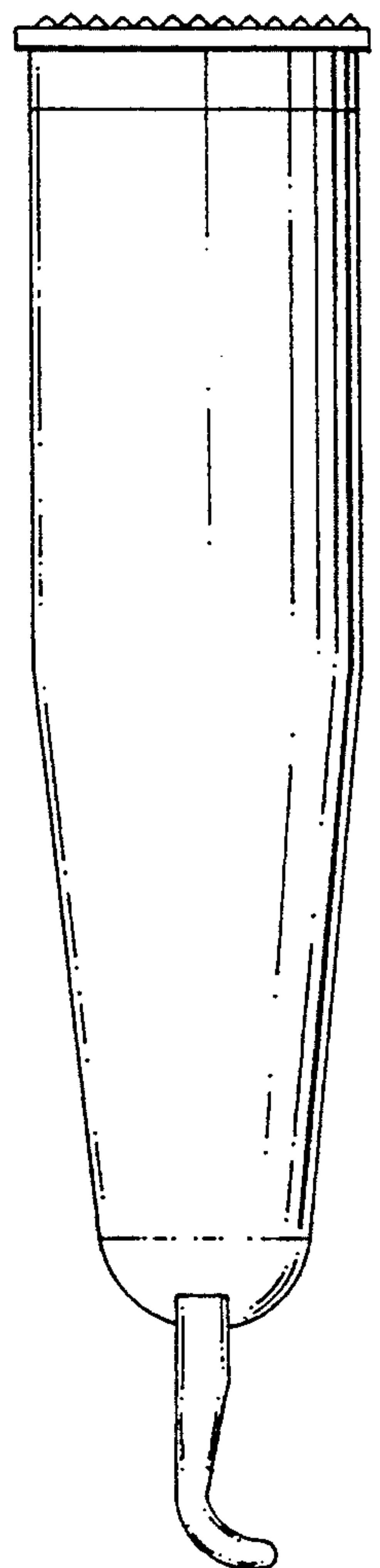

FIG. 5

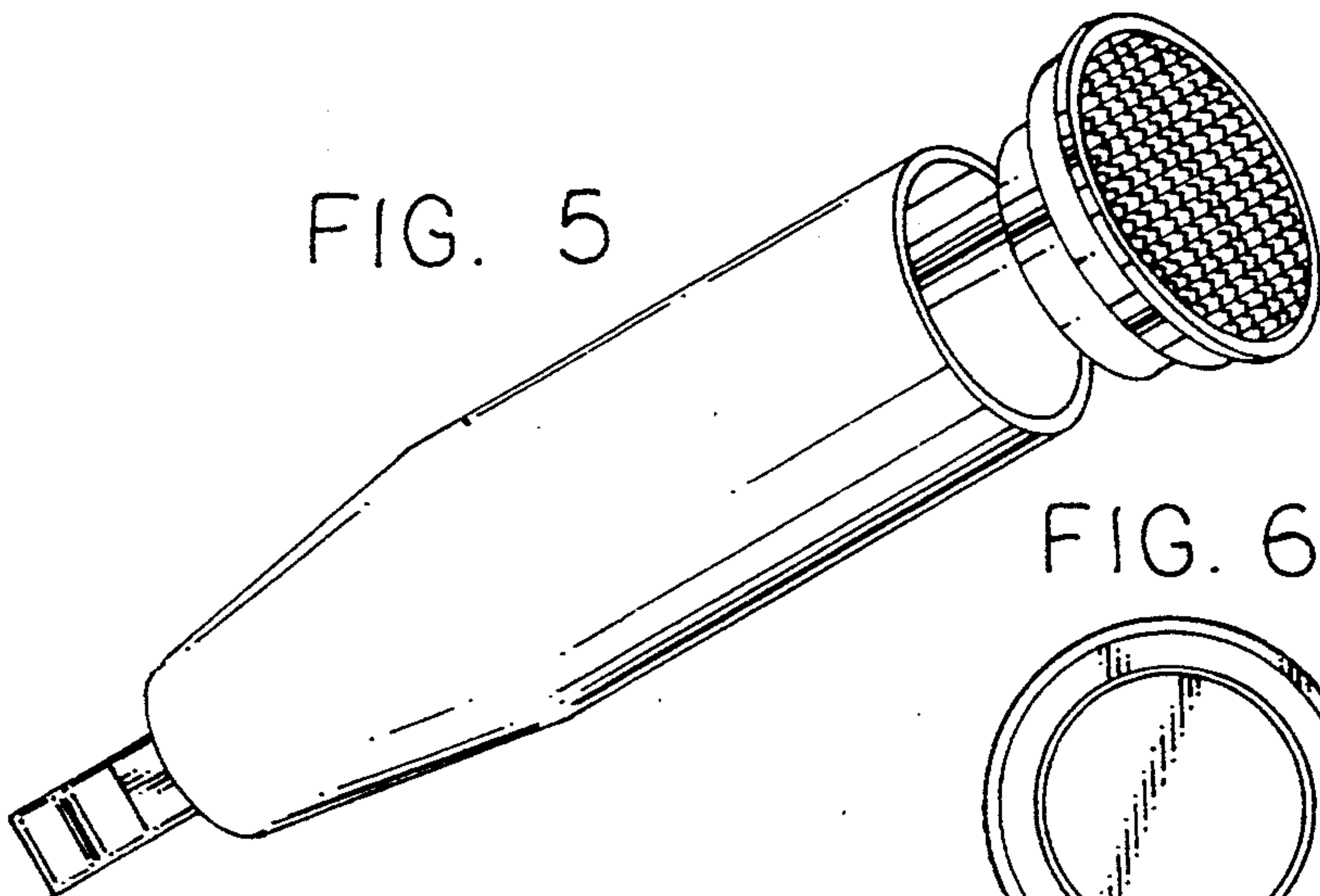

FIG. 7

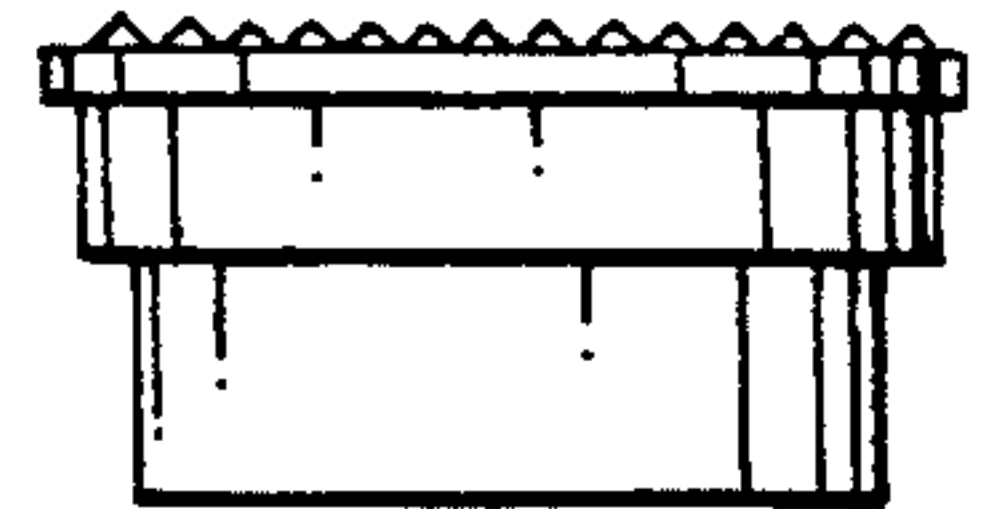

FIG. 6

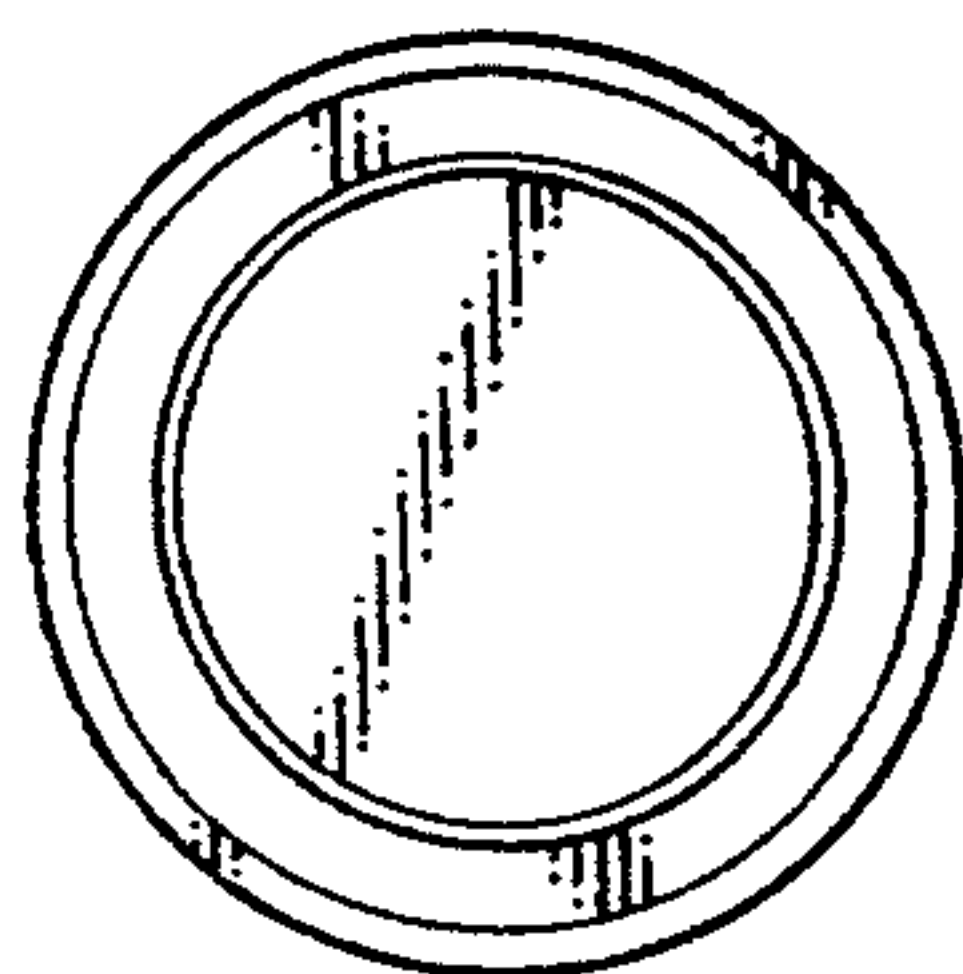

FIG. 8

