



US00D356901S

# United States Patent [19]

[11] Patent Number: **Des. 356,901**

Schoenig et al.

[45] Date of Patent: **\*\* Apr. 4, 1995**

[54] **WORK STAND FOR BICYCLES**

115847 7/1926 Switzerland ..... 211/22

[75] Inventors: **Darrell A. Schoenig; Jonathan P. Workman**, both of Fort Collins, Colo.

[73] Assignee: **Ultimate Support Systems, Inc.**, Fort Collins, Colo.

[\*\*] Term: **14 Years**

[21] Appl. No.: **948,814**

[22] Filed: **Sep. 17, 1992**

[52] U.S. Cl. .... **D6/400; D6/431**

[58] Field of Search ..... **D6/419, 420, 552, 429-431; D12/115, 119, 120; 211/17-22; 269/64, 68, 100; D8/71**

### [56] **References Cited**

#### **U.S. PATENT DOCUMENTS**

D. 229,132	11/1973	Uroshevich	.....	D6/431
D. 268,458	4/1983	Schoenig	.....	D6/29
D. 289,835	5/1987	Schoenig et al.	.....	D6/419 X
D. 330,695	11/1992	Simmons	.....	D12/115
562,250	6/1896	Scribner	.	
577,910	3/1897	Bierbach	.....	211/22
592,534	10/1897	Webster et al.	.....	211/22
594,627	11/1897	Hewlett	.....	211/22
605,429	6/1898	Howard	.....	211/22
619,186	2/1899	Kingsbury	.....	211/22
635,519	7/1900	Masters	.....	211/22
3,514,091	1/1967	Johnson et al.	.....	269/68
3,947,010	3/1976	Zeller	.....	269/100
3,981,491	9/1976	Snyder	.....	269/64

#### **FOREIGN PATENT DOCUMENTS**

1247112	10/1960	France	.....	211/22
---------	---------	--------	-------	--------

### **OTHER PUBLICATIONS**

Blackburn Designs, Inc., Campbell, Calif.; 1992 catalog, pp. 24, 25.

Performance Bicycle Shop, Chapel Hill, N.C.; Holiday 1991 catalog, p. 70.

Park Tool Company, St. Paul, Minn.; 1991 catalog, pp. 19-23.

*Primary Examiner*—Carmen H. Vales-Lado

### [57] **CLAIM**

The ornamental design for a work stand for bicycles, as shown and described.

### **DESCRIPTION**

FIG. 1 is an enlarge broken away front perspective view of the arm of the work stand for bicycles showing our new design;

FIG. 2 is a front elevational view thereof;

FIG. 3 is a side elevational view thereof from one side; the elevational view from the opposite side is a mirror image;

FIG. 4 is a rear elevational view thereof;

FIG. 5 is a top plan view thereof;

FIG. 6 is a bottom plan view thereof;

FIG. 7 is the front perspective view of the work stand for bicycles;

FIG. 8 is the front elevational view of the work stand for bicycles;

FIG. 9 is the left side elevational view thereof;

FIG. 10 is the right side elevational view thereof;

FIG. 11 is the rear elevational view thereof;

FIG. 12 is the top plan view thereof; and,

FIG. 13 is the bottom plan view of the work stand for bicycles.

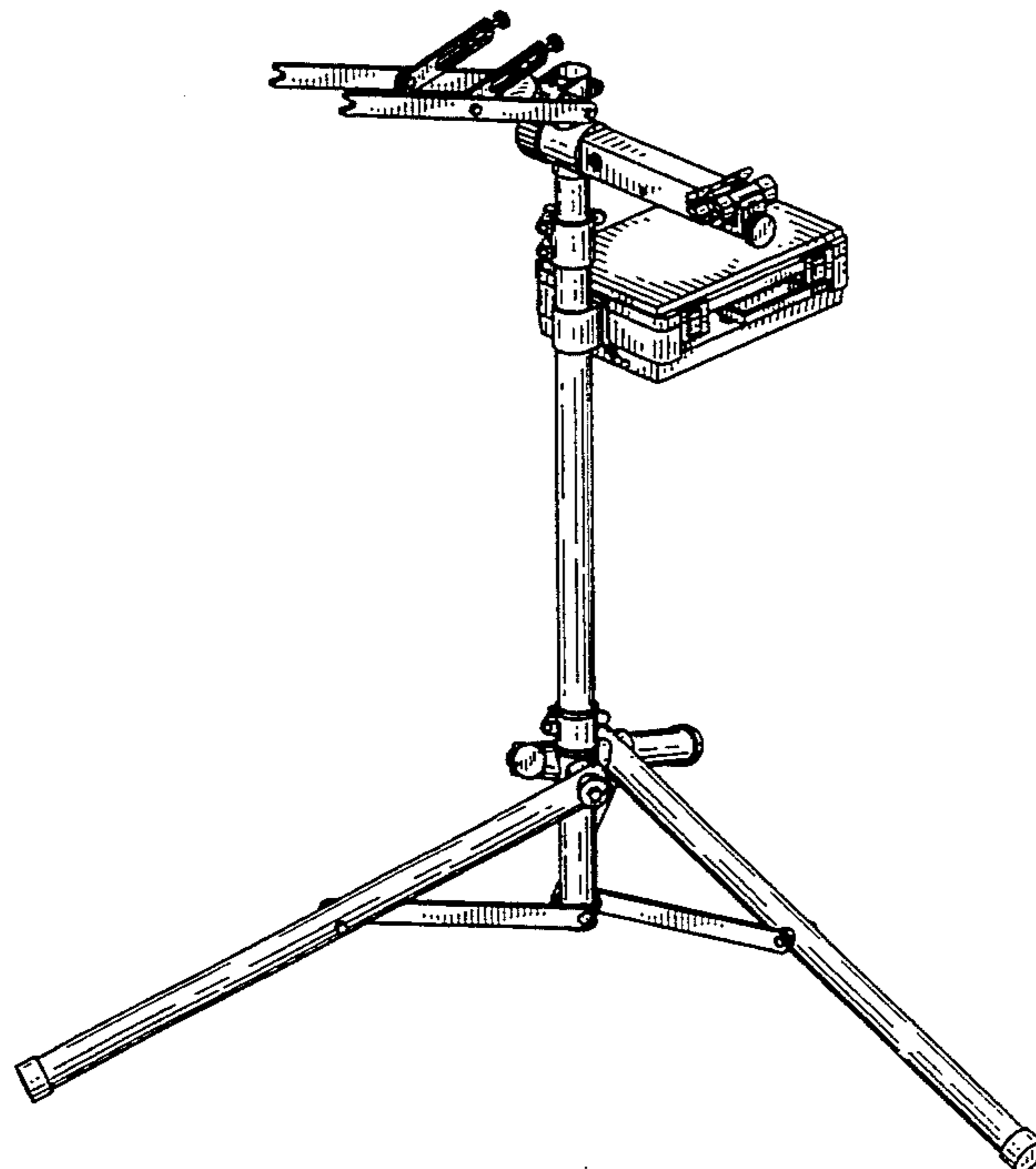

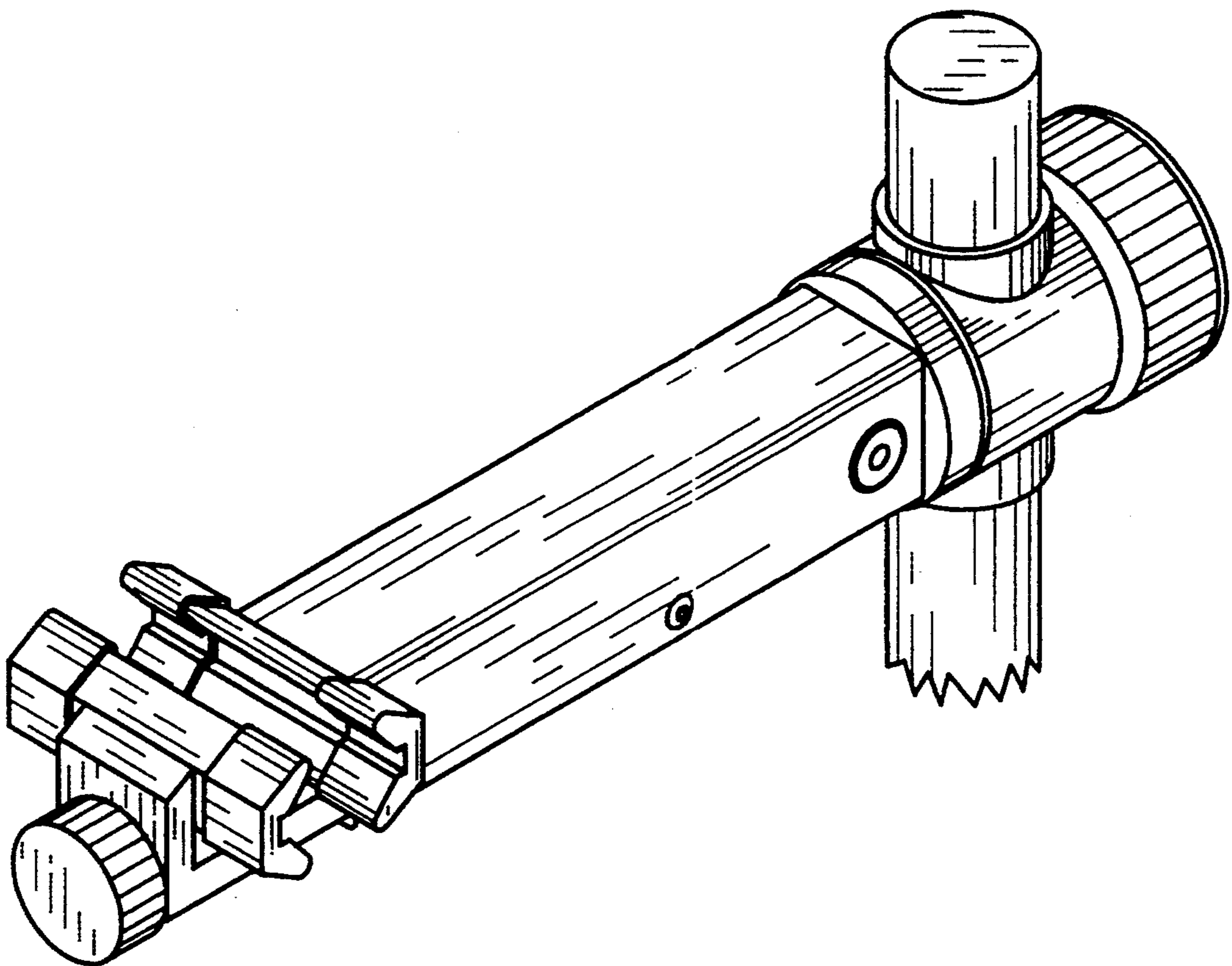

Fig. 1

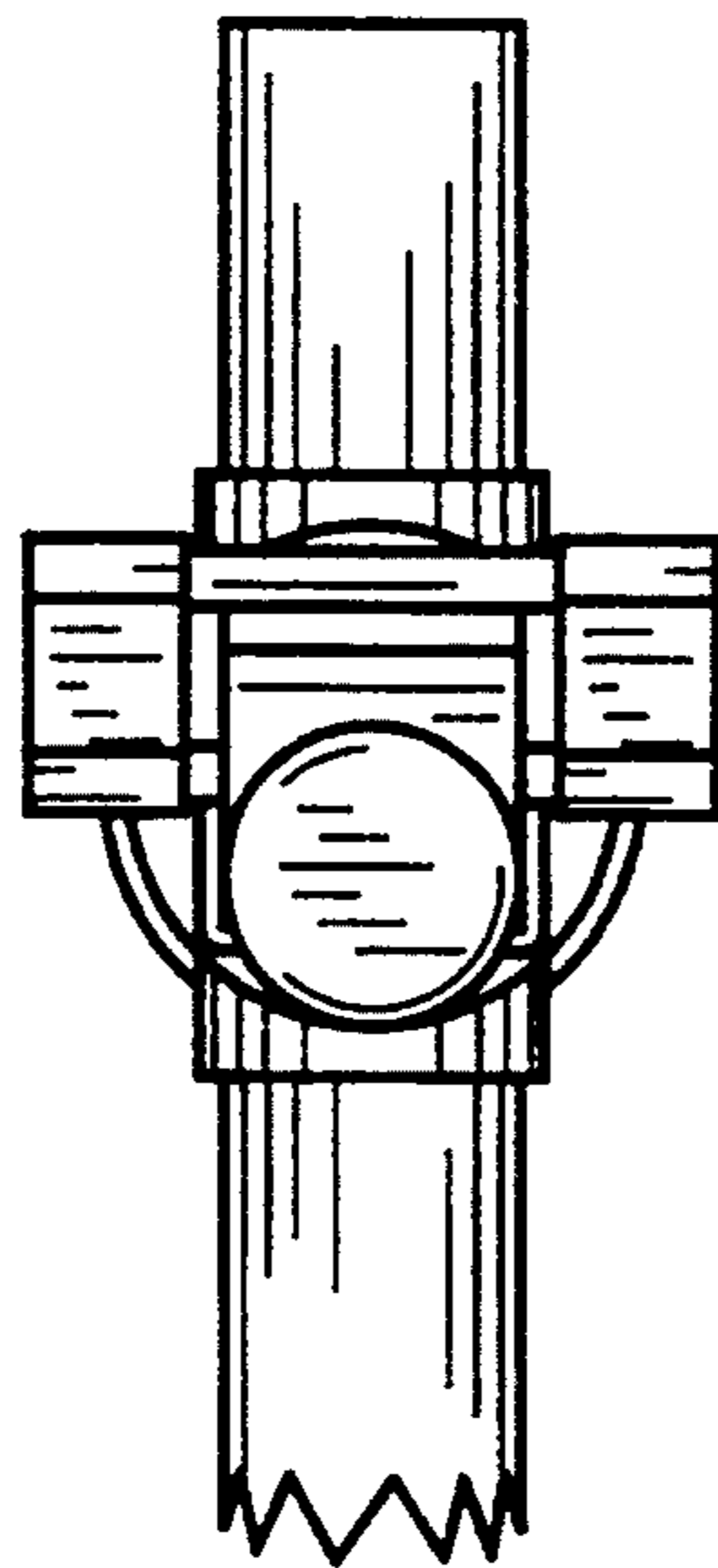

Fig. 2

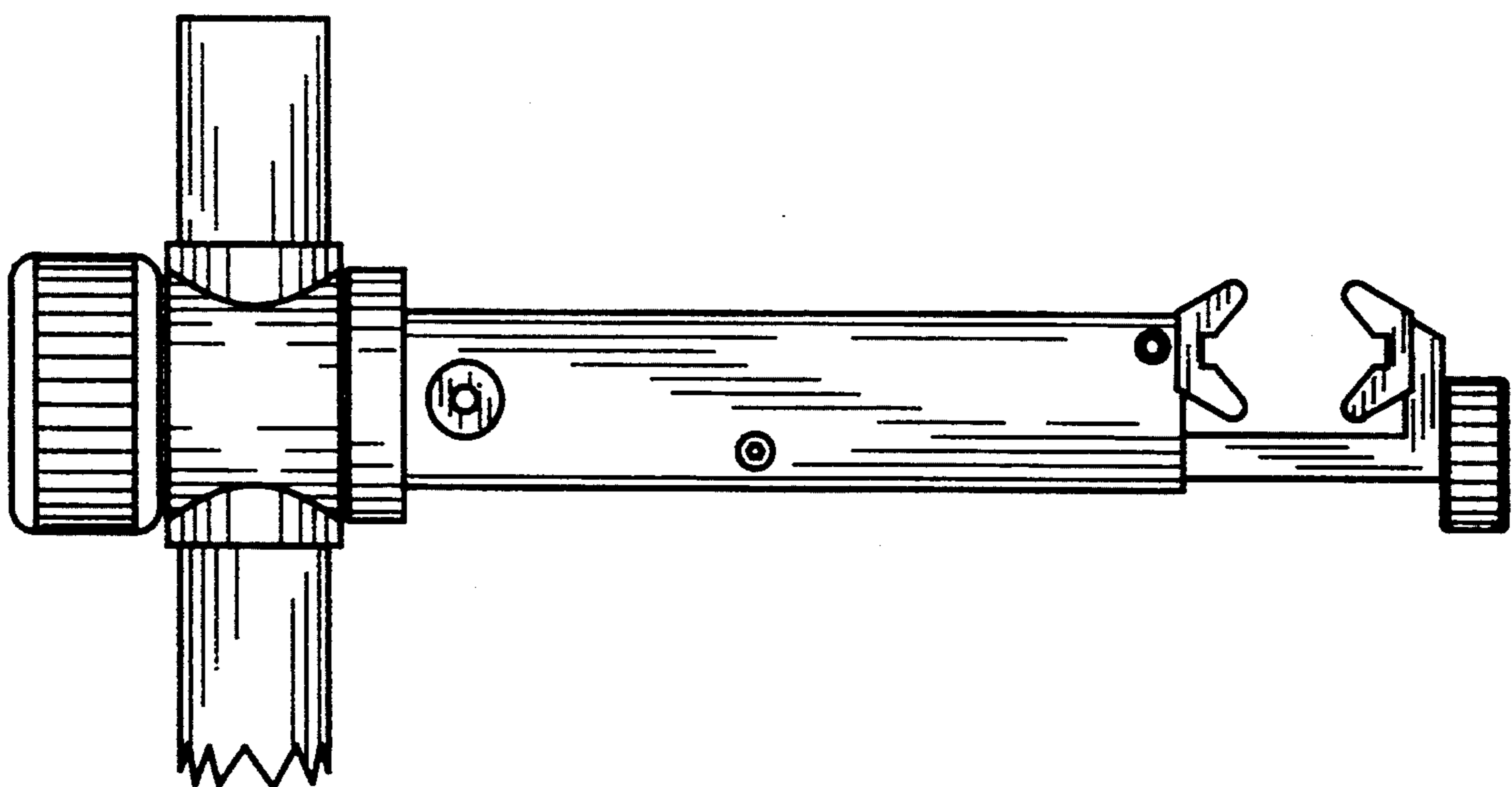

Fig. 3

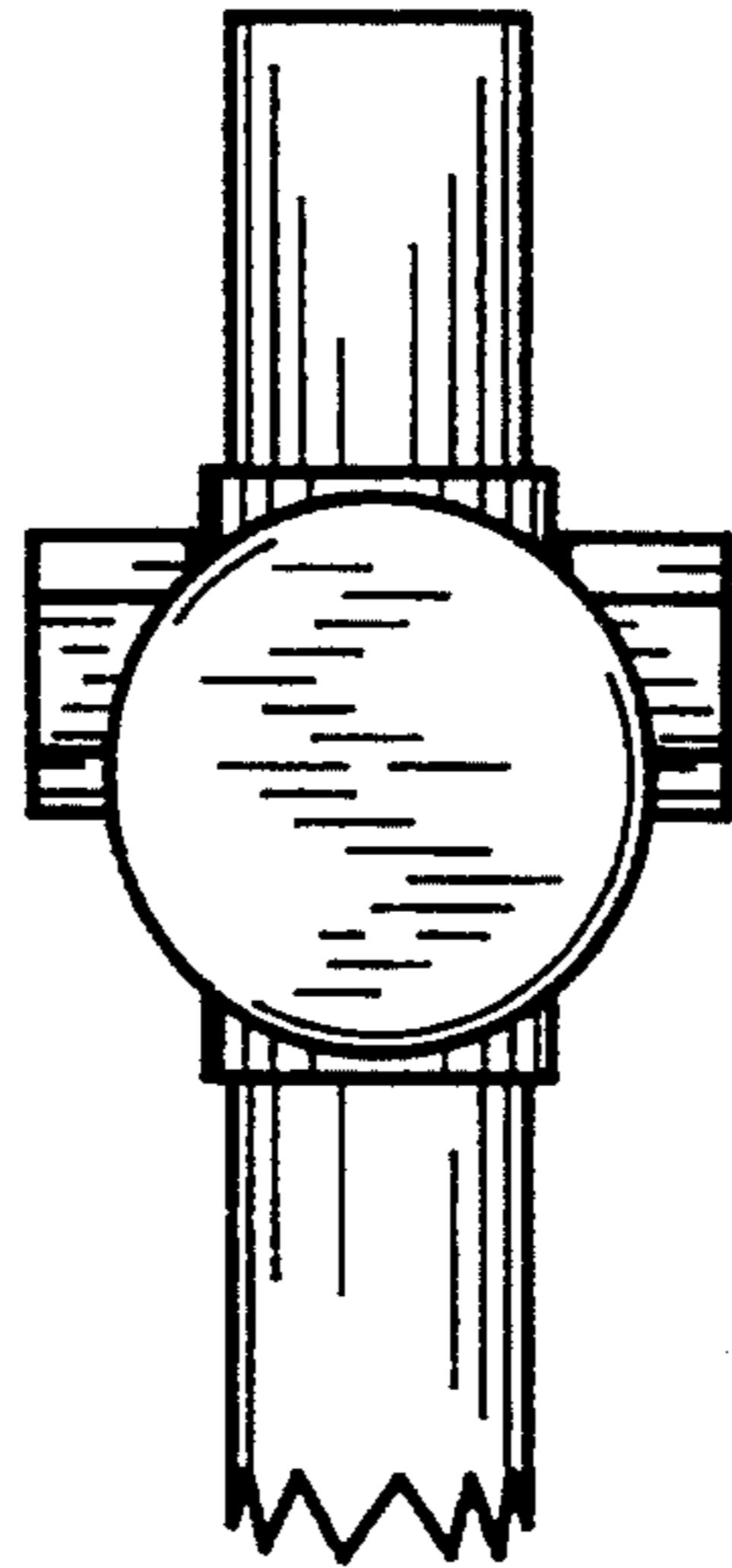

Fig. 4

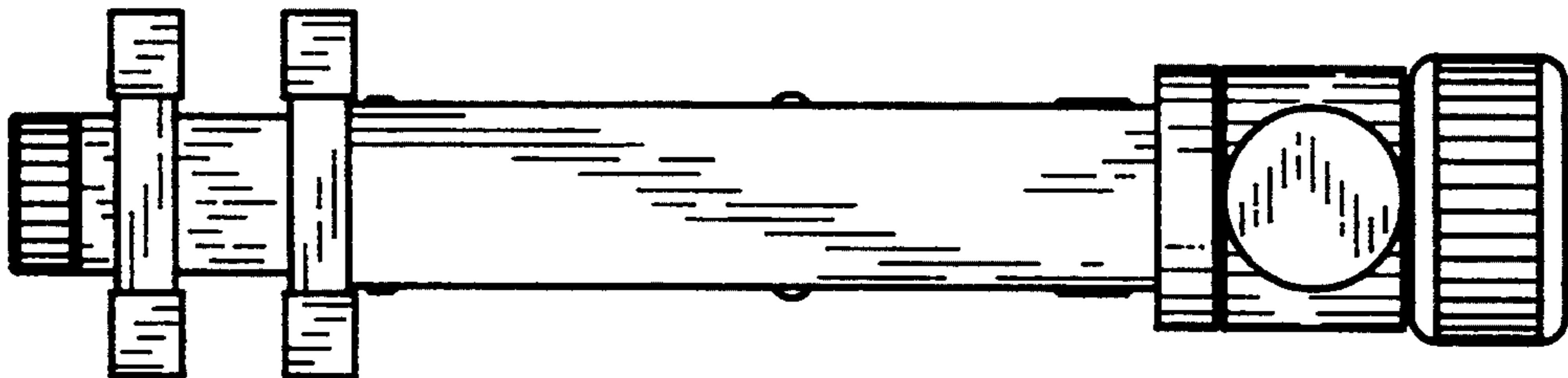

Fig. 5

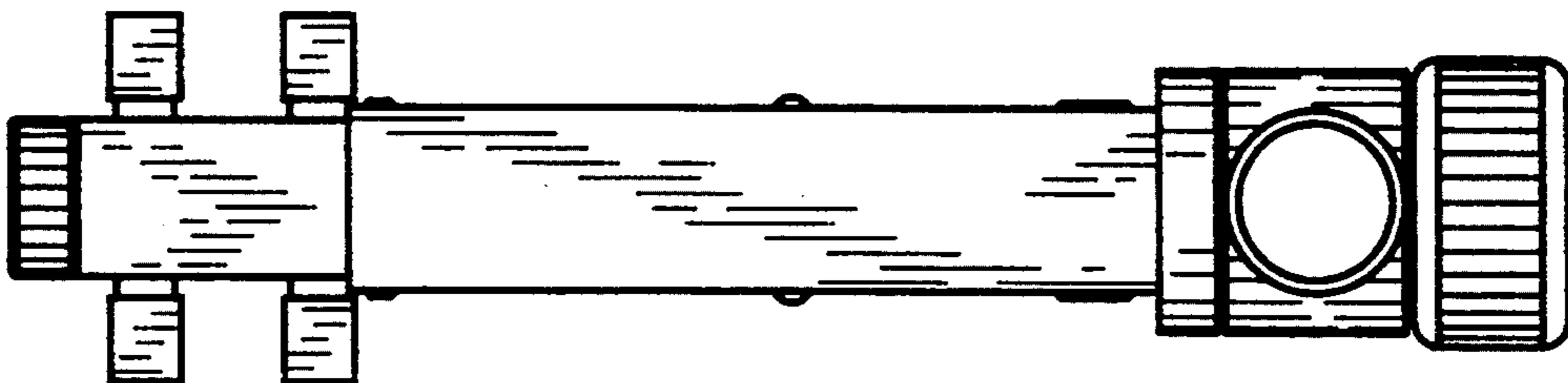

Fig. 6

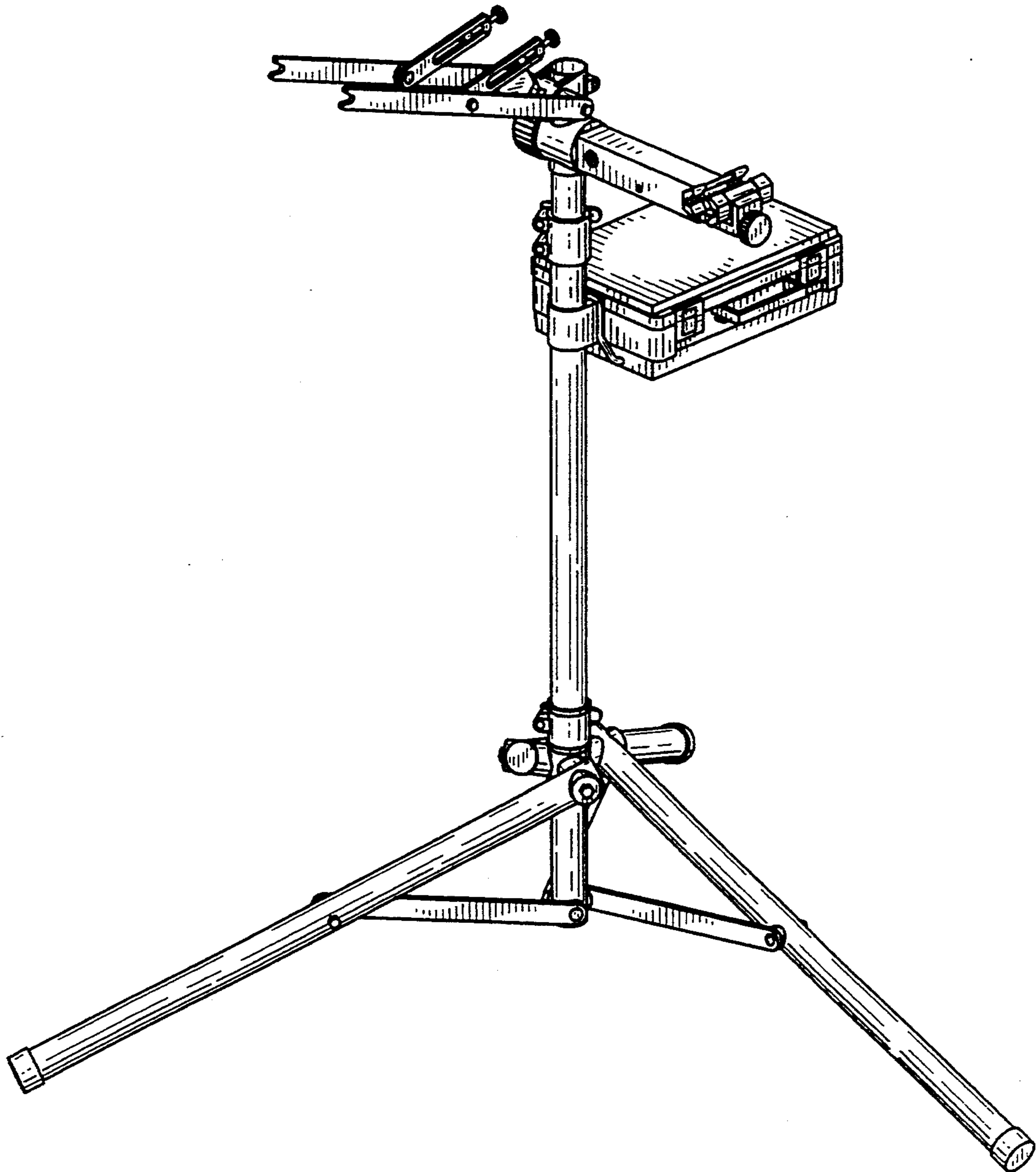

Fig. 7

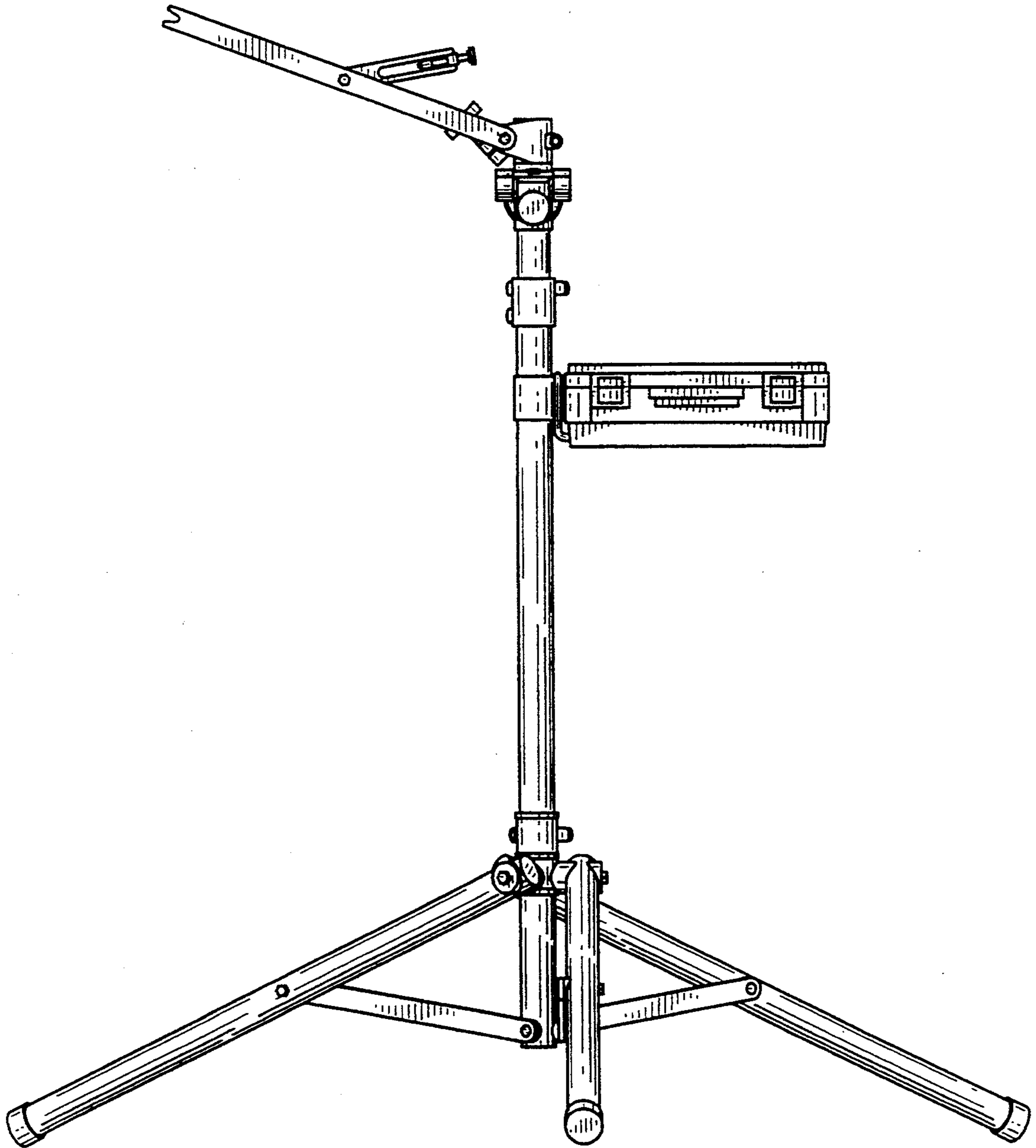

Fig. 8

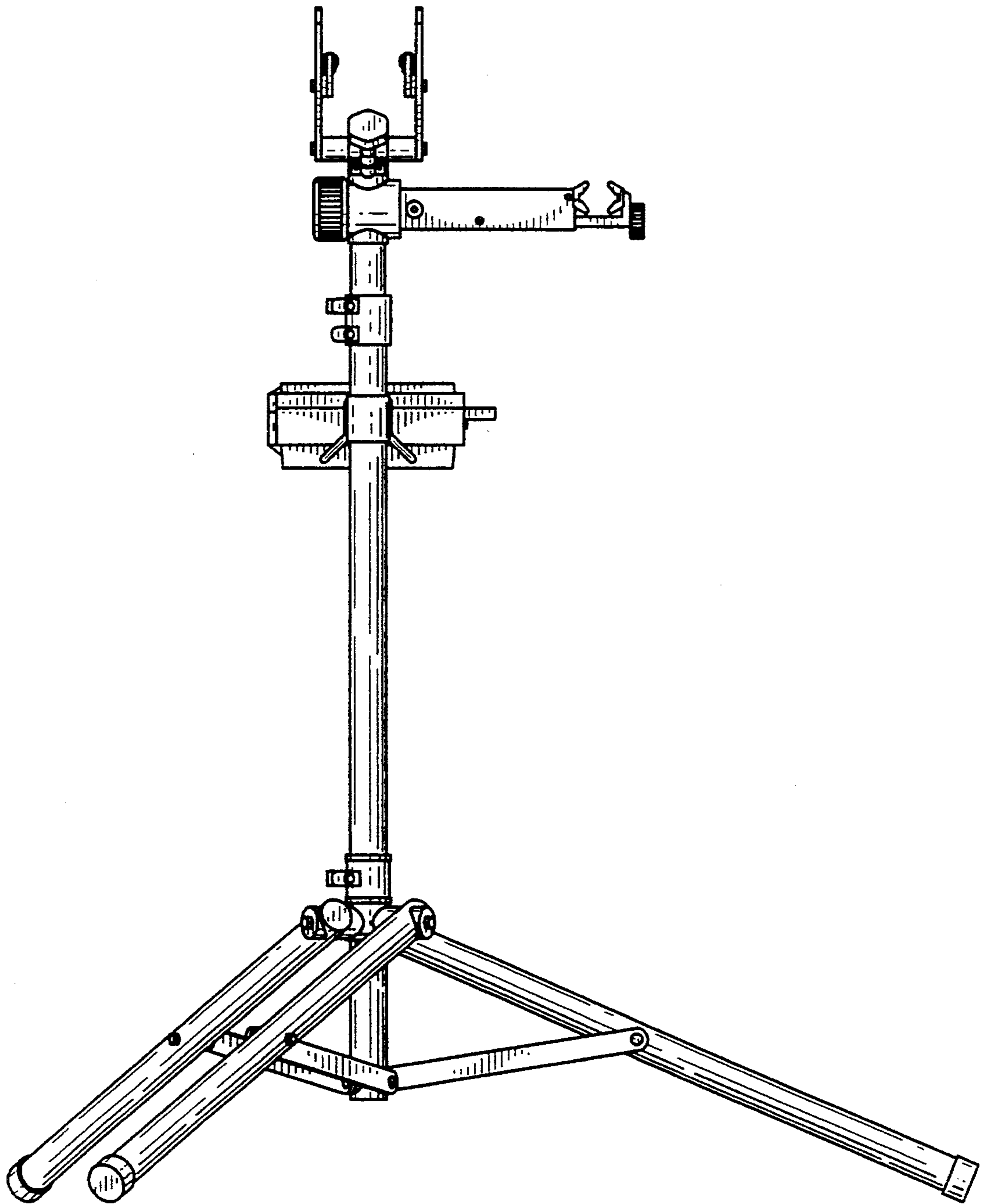

Fig. 9

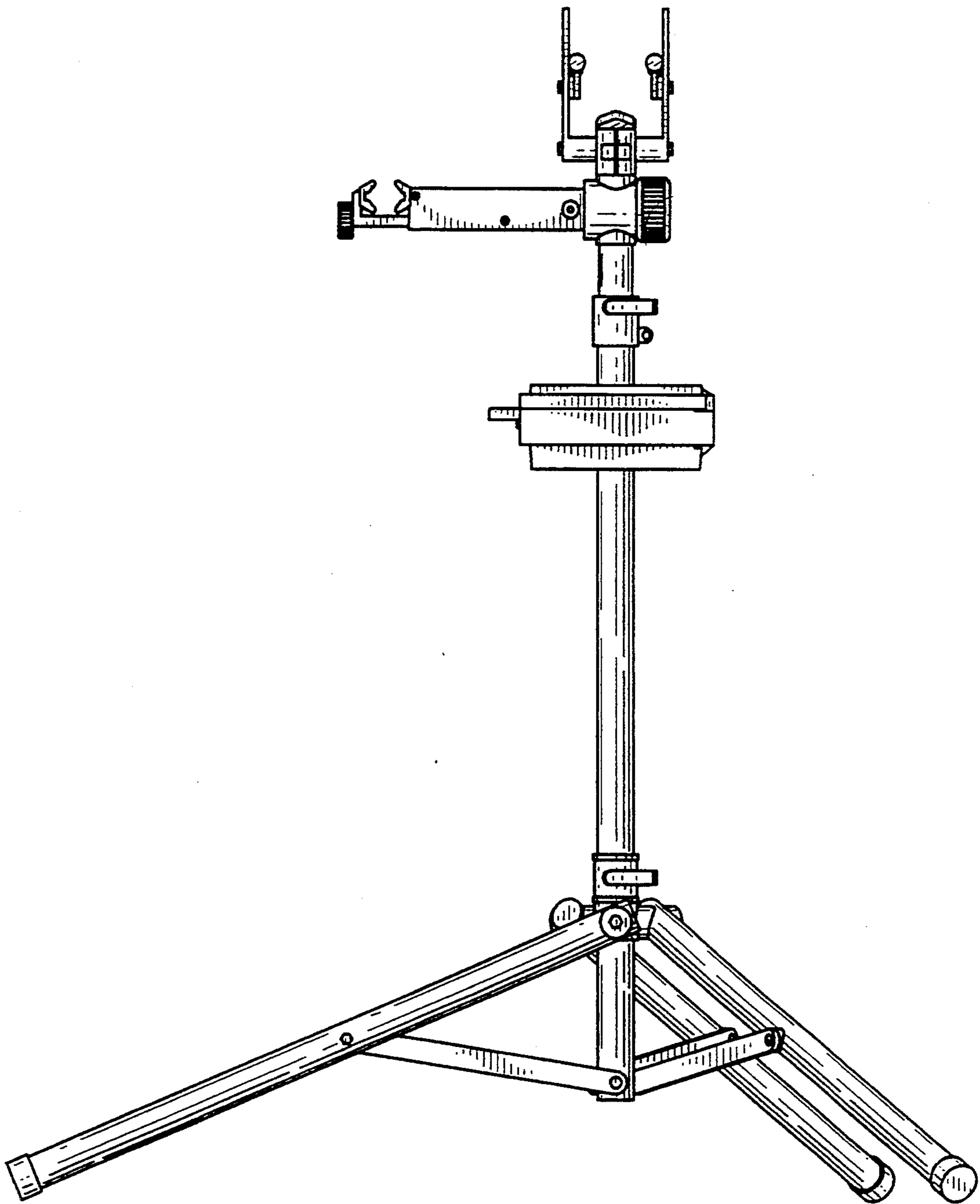

Fig. 10



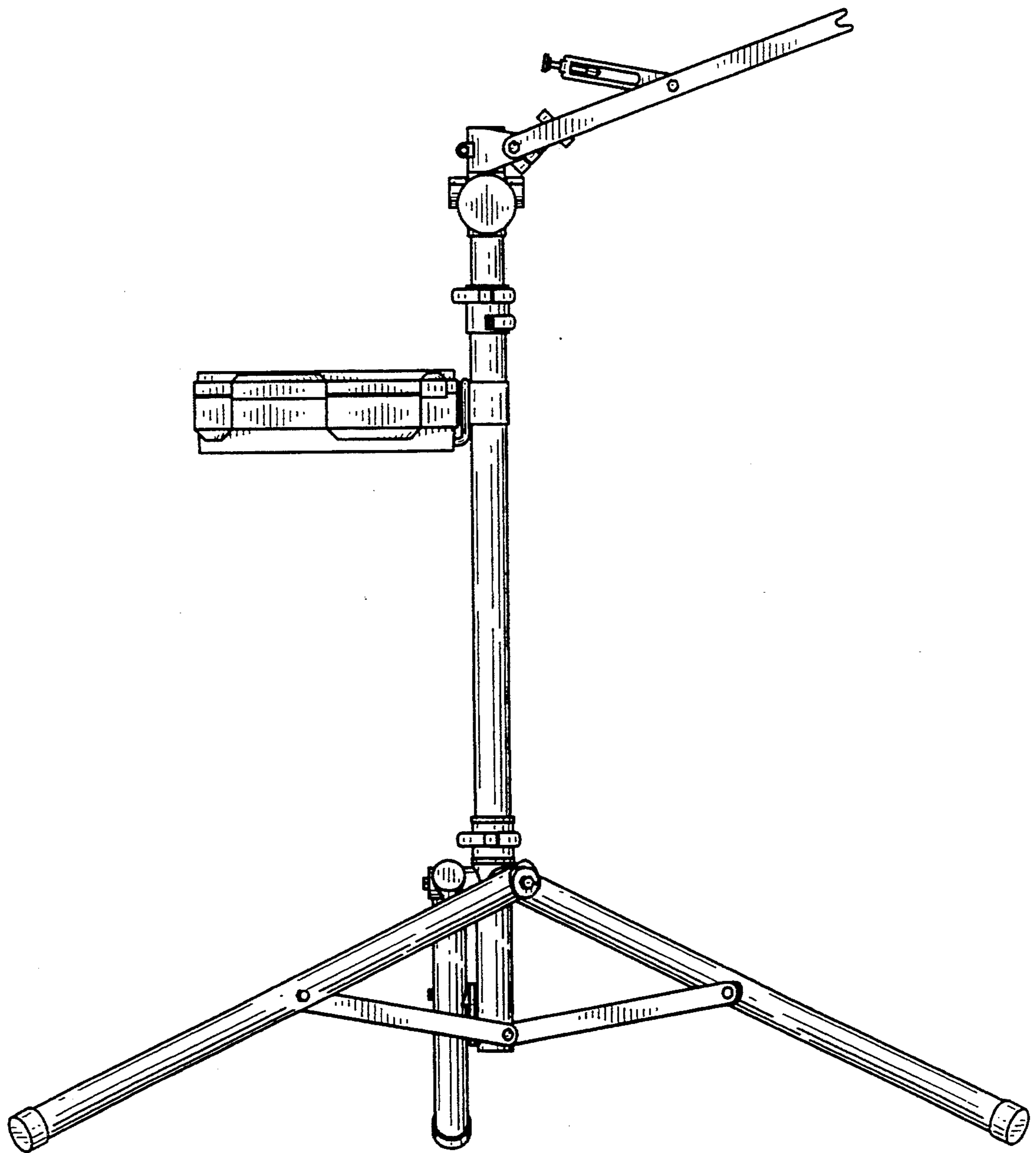

Fig. 11

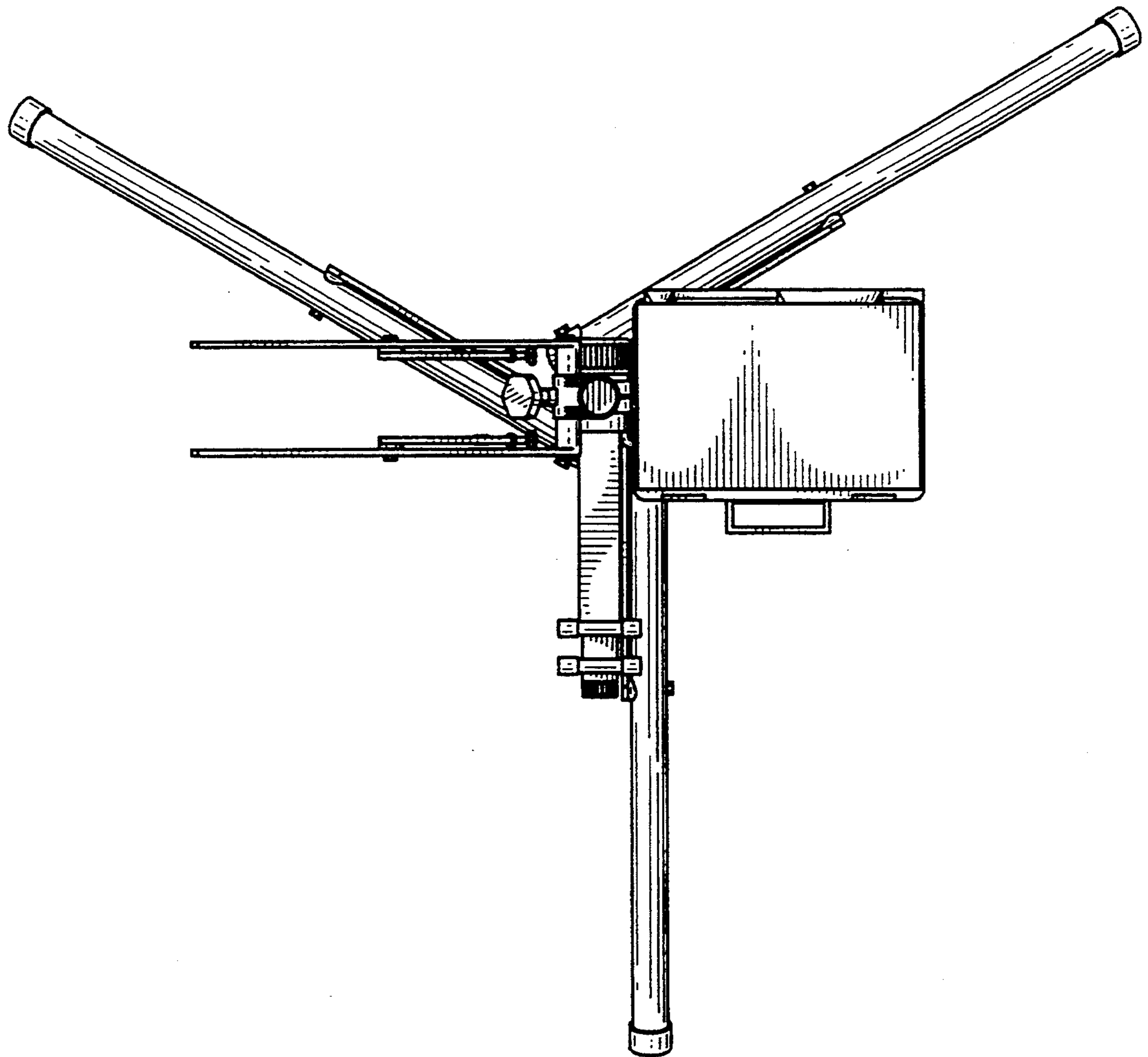

Fig. 12

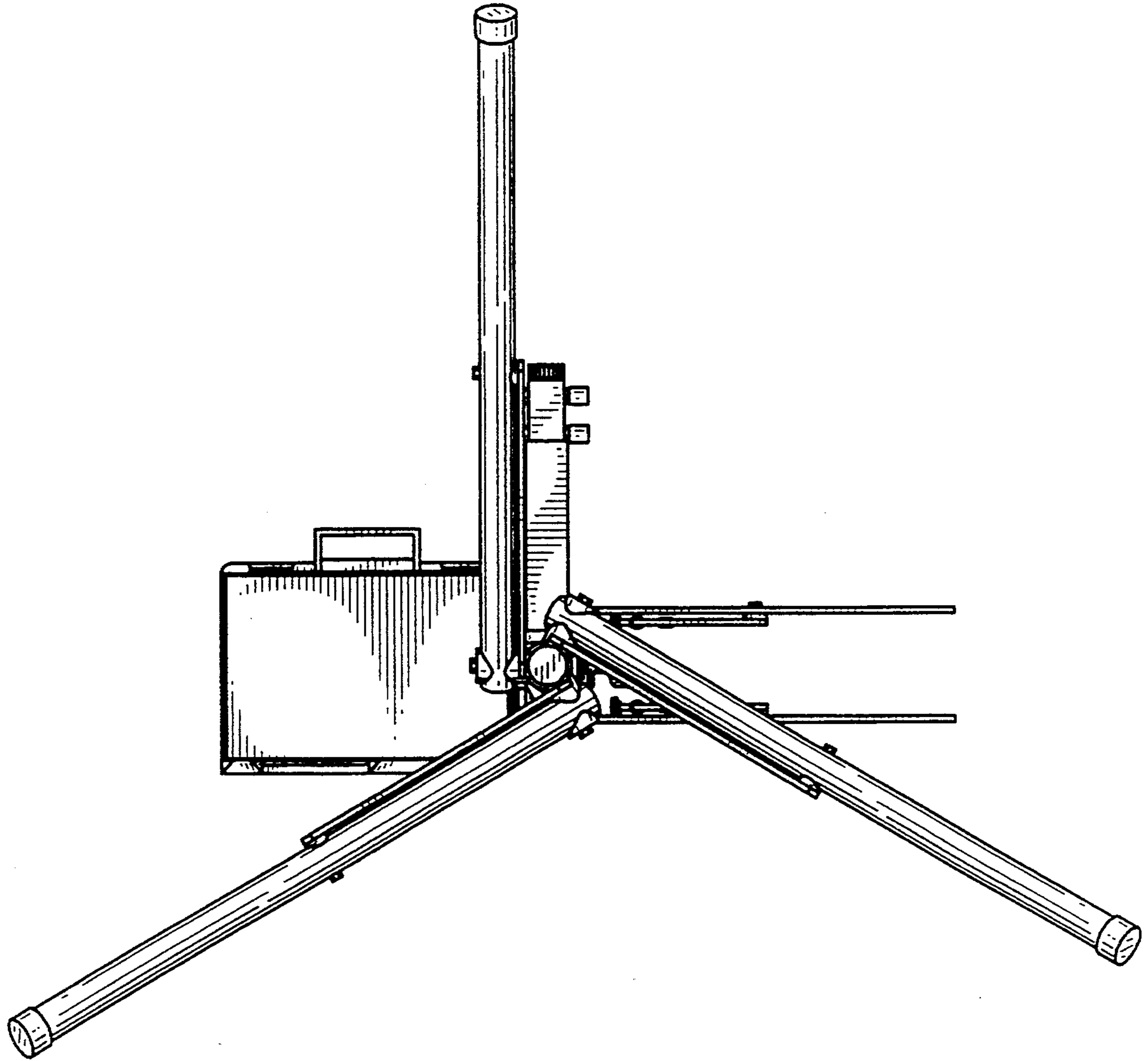

Fig. 13