



US00D356799S

United States Patent [19]

Gardner

[11] Patent Number: **Des. 356,799**

[45] Date of Patent: **** Mar. 28, 1995**

[54] TILT TUBE FOR OUTBOARD MOTORS

[76] Inventor: **John K. Gardner**, P.O. Box 2730,
Texas City, Tex. 77592-2730

[**] Term: **14 Years**

[21] Appl. No.: **6,192**

[22] Filed: **Mar. 18, 1993**

[52] U.S. Cl. **D15/4**

[58] Field of Search **D15/1-9.2;**
114/144 R; 74/480 B

[56] **References Cited**

U.S. PATENT DOCUMENTS

D. 233,801	11/1974	Giacosa	D15/4
D. 260,523	9/1981	Rains, III et al.	D15/4
D. 264,084	4/1982	Morgan	D15/4
D. 295,867	5/1988	Walsh	D15/4
D. 304,947	12/1989	Reynolds	D15/4
3,861,348	1/1975	Beierle	440/6
4,496,326	1/1985	Boda	114/144 R X
4,553,496	11/1985	Foresman	114/144 R
4,735,166	4/1988	Dimalanta	74/480 B X

Primary Examiner—Ralf T. Seifert

Attorney, Agent, or Firm—Kenneth A. Roddy

[57] **CLAIM**

The ornamental design for a tilt tube for outboard motors, as shown and described.

DESCRIPTION

FIG. 1 is a perspective view of a tilt tube for outboard motors showing my new design from the top, one end, and one side;

FIG. 2 is a perspective view thereof shown from the top and the end and side opposite that shown in FIG. 1;

FIG. 3 is a perspective view thereof shown from the bottom and the end and side shown in FIG. 2;

FIG. 4 is a left end view thereof as shown in FIG. 1;

FIG. 5 is a right end view thereof as shown in FIG. 1;

FIG. 6 is a perspective view of a second embodiment of the tilt tube for outboard motors showing my new design, from the top, one end and one side;

FIG. 7 is a perspective view thereof shown from the top and the end and side opposite that shown in FIG. 6;

FIG. 8 is a perspective view thereof shown from the bottom and the end and side shown in FIG. 7;

FIG. 9 is a left end view thereof as shown in FIG. 6; and,

FIG. 10 is a right end view thereof as shown in FIG. 6.

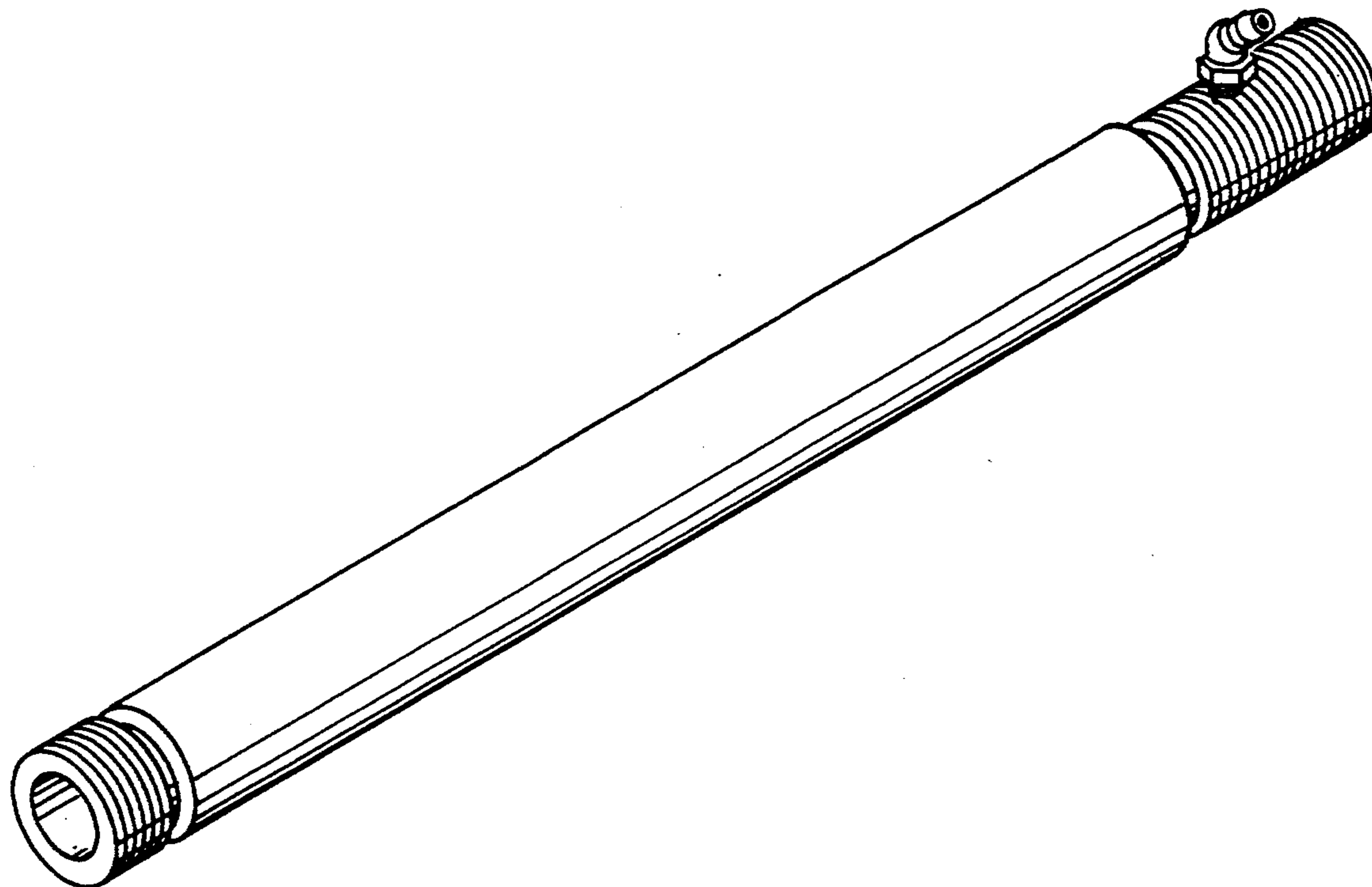

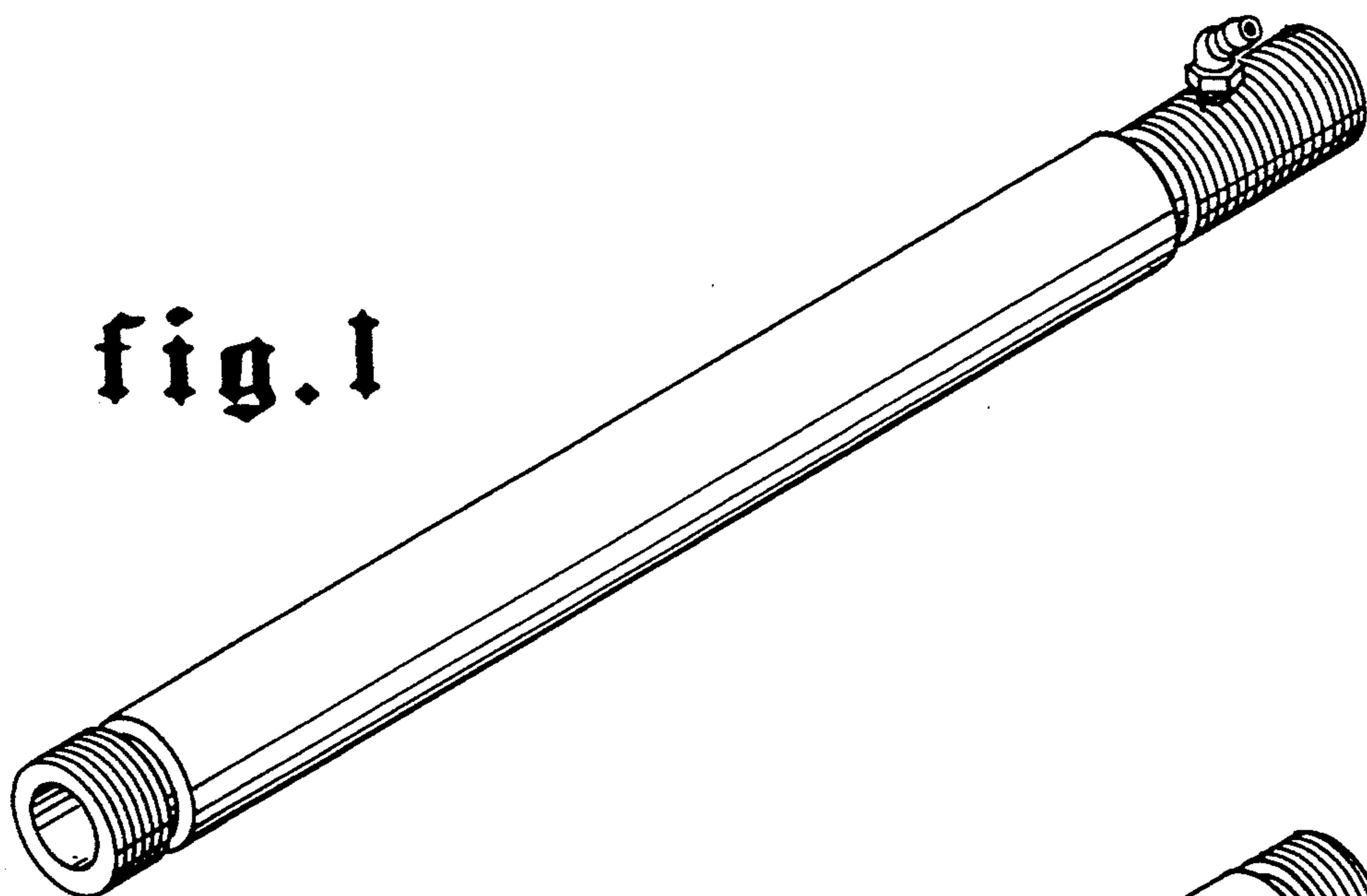

fig. 1

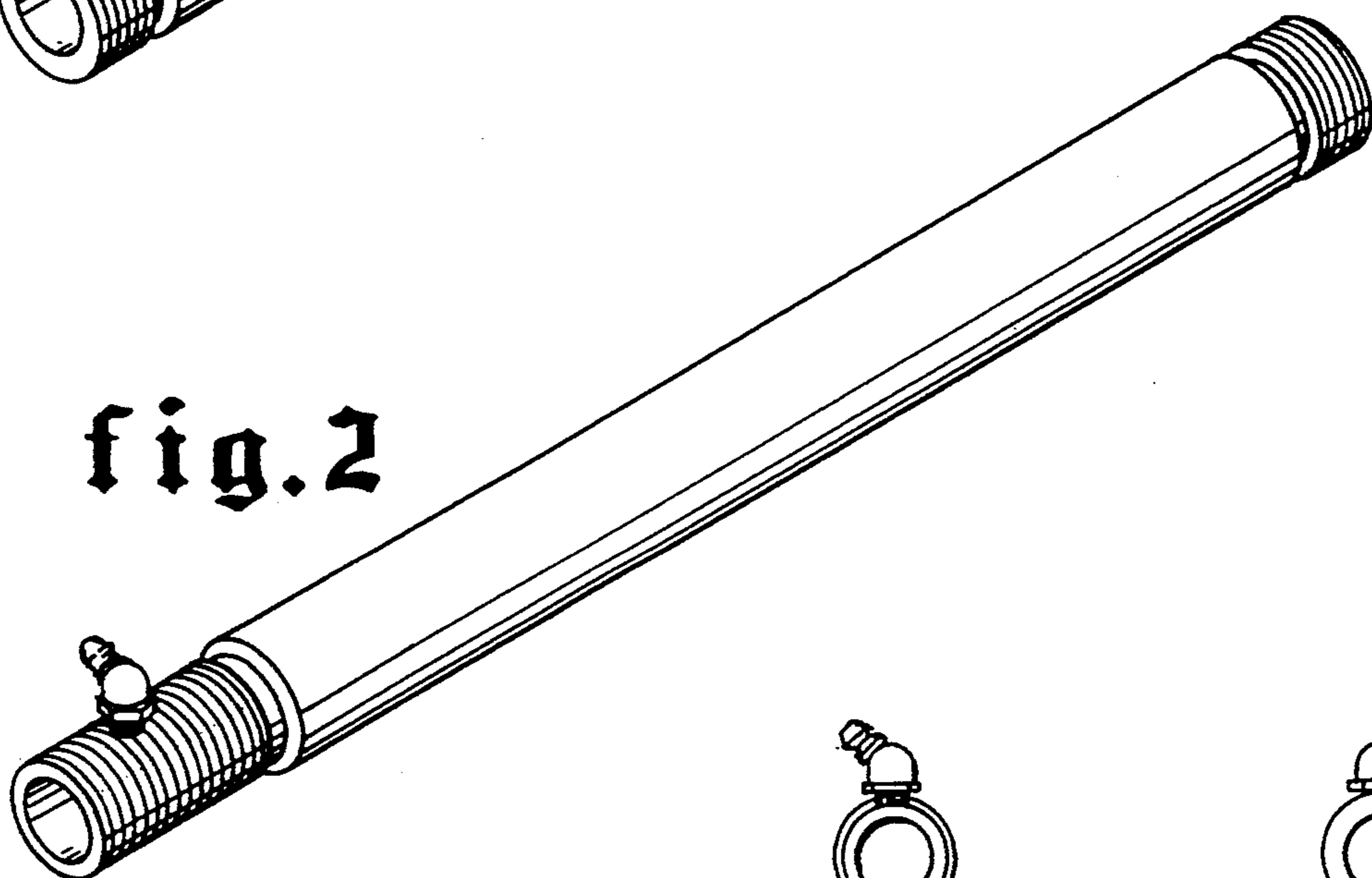

fig. 2



fig. 4



fig. 5

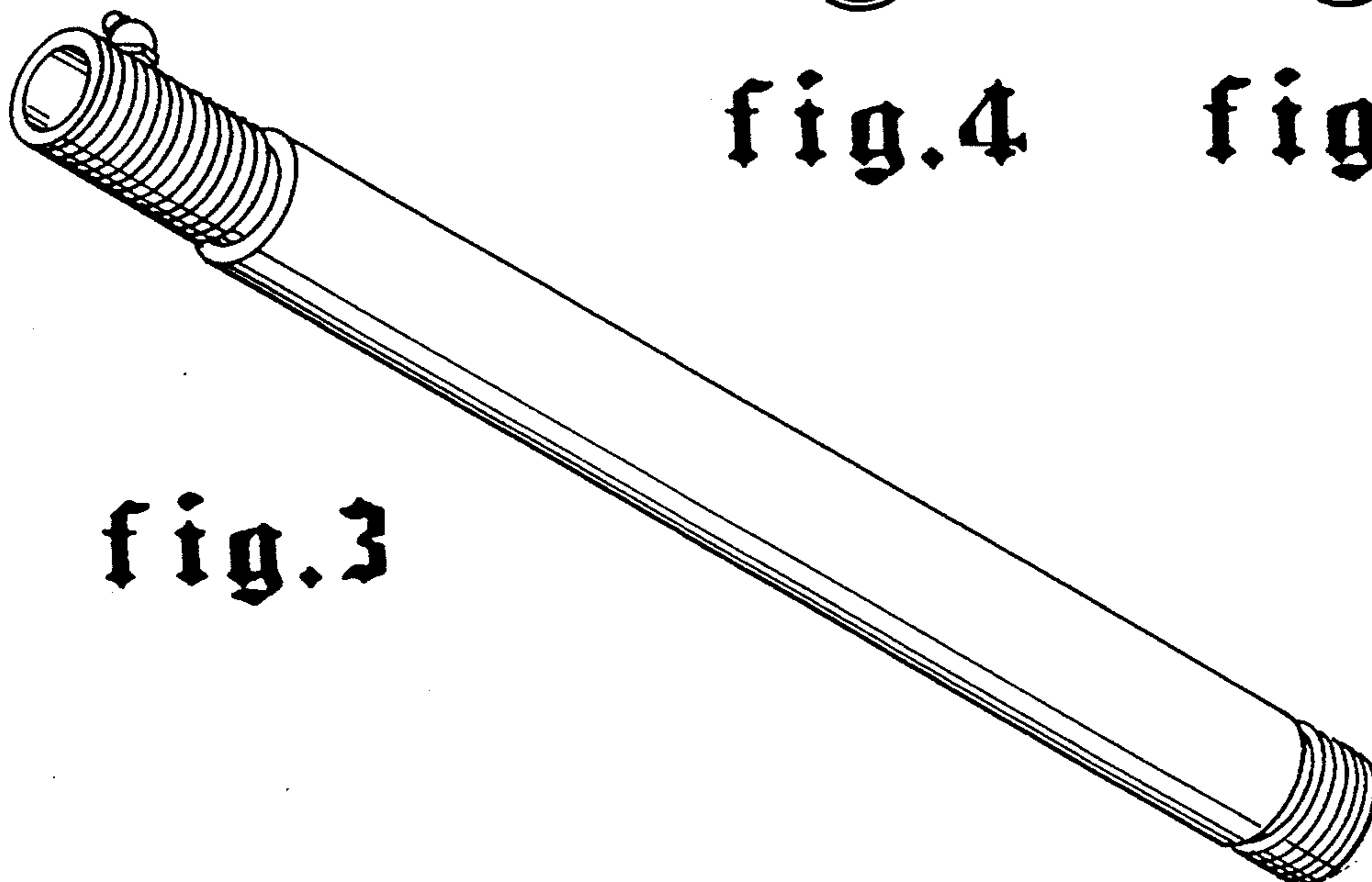

fig. 3

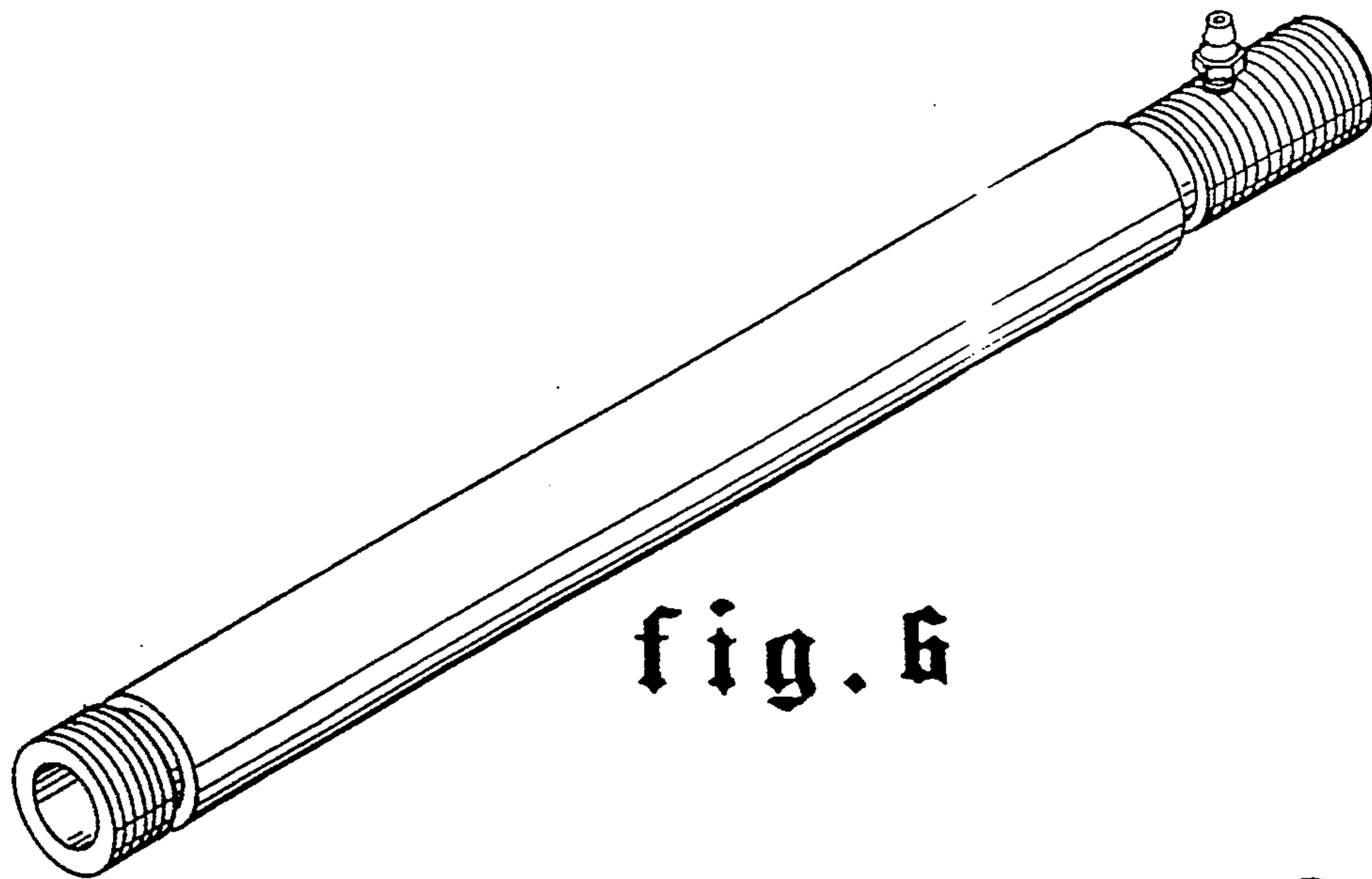

fig. 6

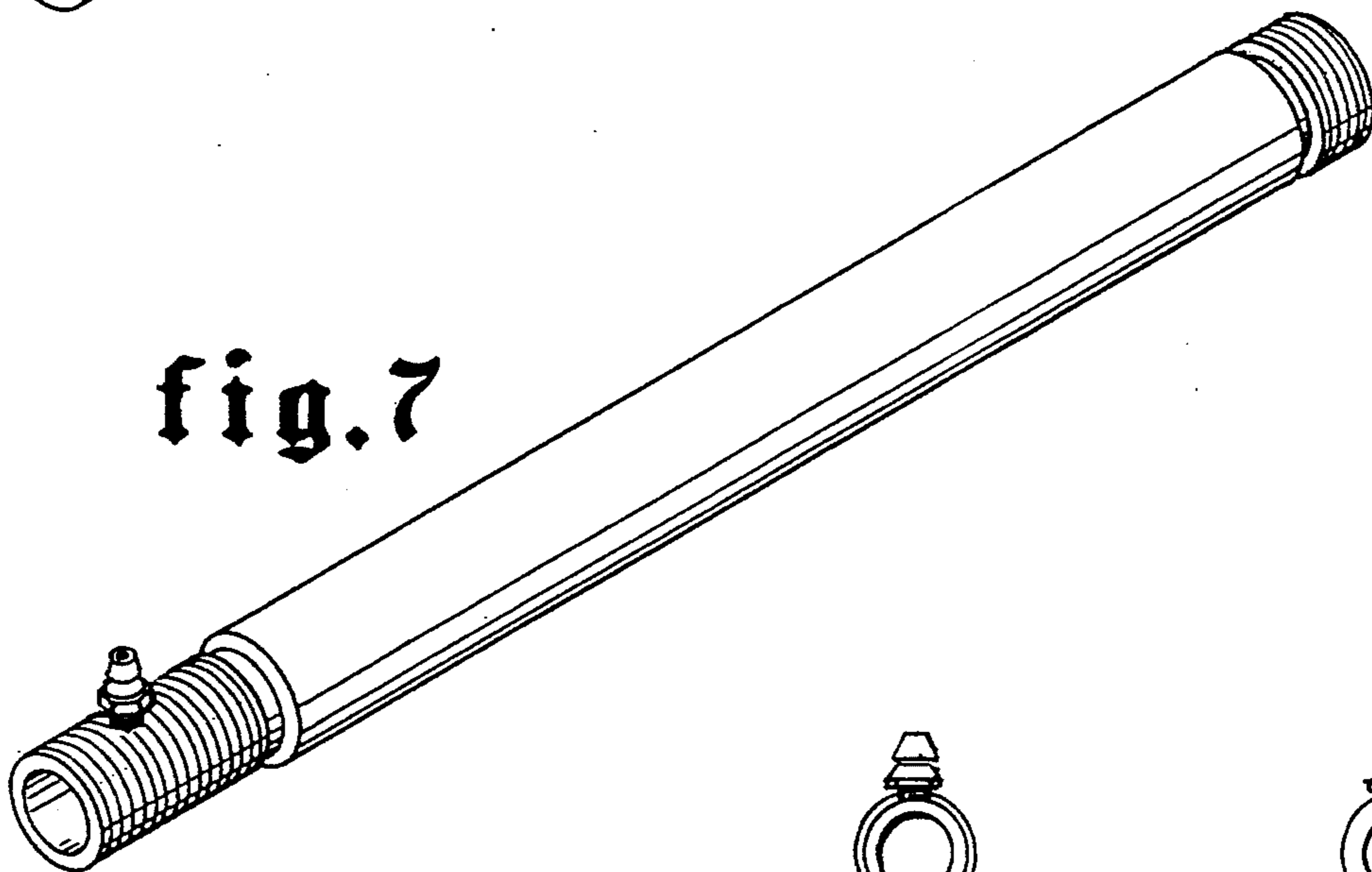

fig. 7



fig. 9



fig. 10

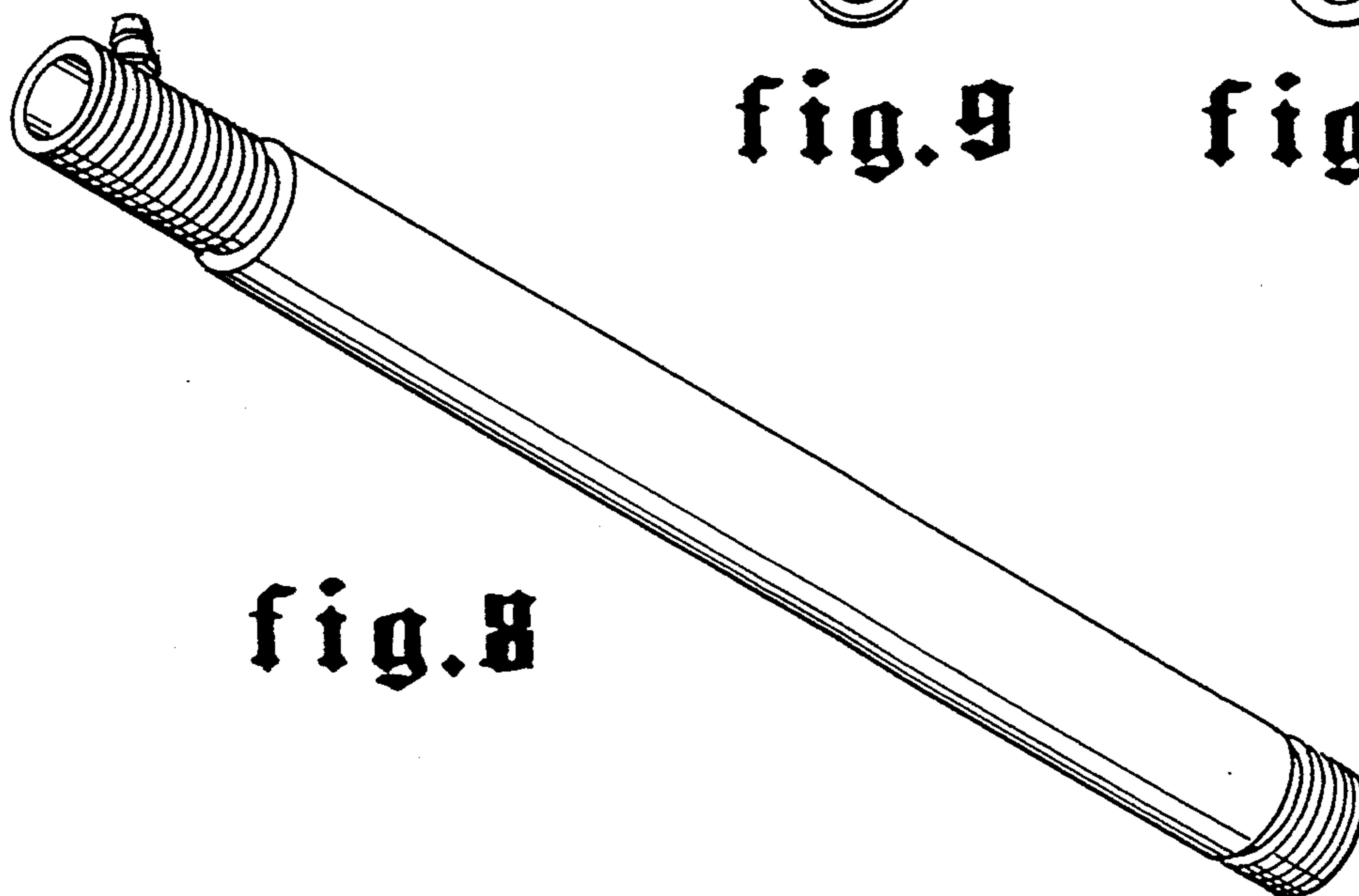

fig. 8