



US00D356758S

United States Patent [19]

[11] Patent Number: Des. 356,758

Ackerman et al.

[45] Date of Patent: ** Mar. 28, 1995

[54] VEHICLE

[75] Inventors: **Robert S. Ackerman**, West Bloomfield; **David Smith**, Detroit; **John E. Crain**, Birmingham; **John E. Herlitz**, Farmington Hills; **Lance R. Wagner**, Lake Orion, all of Mich.

[73] Assignee: **Chrysler Corporation**, Highland Park, Mich.

[**] Term: **14 Years**

[21] Appl. No.: **11,139**

[22] Filed: **Jul. 27, 1993**

[52] U.S. Cl. **D12/92**

[58] Field of Search **D12/91, 92; 296/185**

[56] References Cited

U.S. PATENT DOCUMENTS

- D. 335,838 5/1993 Manoogian, II et al. D12/92
- D. 336,868 6/1993 Dehner et al. D12/92
- D. 338,853 8/1993 Folden et al. D12/92

OTHER PUBLICATIONS

Car & Driver, Oct. 1992, p. 34, Chrysler PL Subcompact Automobile, top of page.

Primary Examiner—James M. Gandy
Attorney, Agent, or Firm—Mark P. Calcaterra

[57] CLAIM

The ornamental design for a vehicle, as shown and described.

DESCRIPTION

FIG. 1 is a front perspective view of a first embodiment of a vehicle having two doors constructed in accordance with the teachings of the present invention, it being understood that the roof is plain and unornamented;

FIG. 2 is a rear perspective view of the vehicle shown in FIG. 1;

FIG. 3 is a side view of the vehicle shown in FIG. 1, it being understood that the side opposite to that shown is a substantial mirror image thereof;

FIG. 4 is a front elevational view of the vehicle shown in FIG. 1;

FIG. 5 is a rear elevational view of the vehicle shown in FIG. 1;

FIG. 6 is a side view of a second embodiment of a vehicle having four doors constructed in accordance with the teachings of the present invention, it being understood that the roof is plain and unornamented and that the front and rear views of the second embodiment are substantial identical to the front and rear views, respectively, of the first embodiment;

FIG. 7 is a front perspective view of the vehicle shown in FIG. 6; and,

FIG. 8 is a rear perspective view of the vehicle shown in FIG. 6.

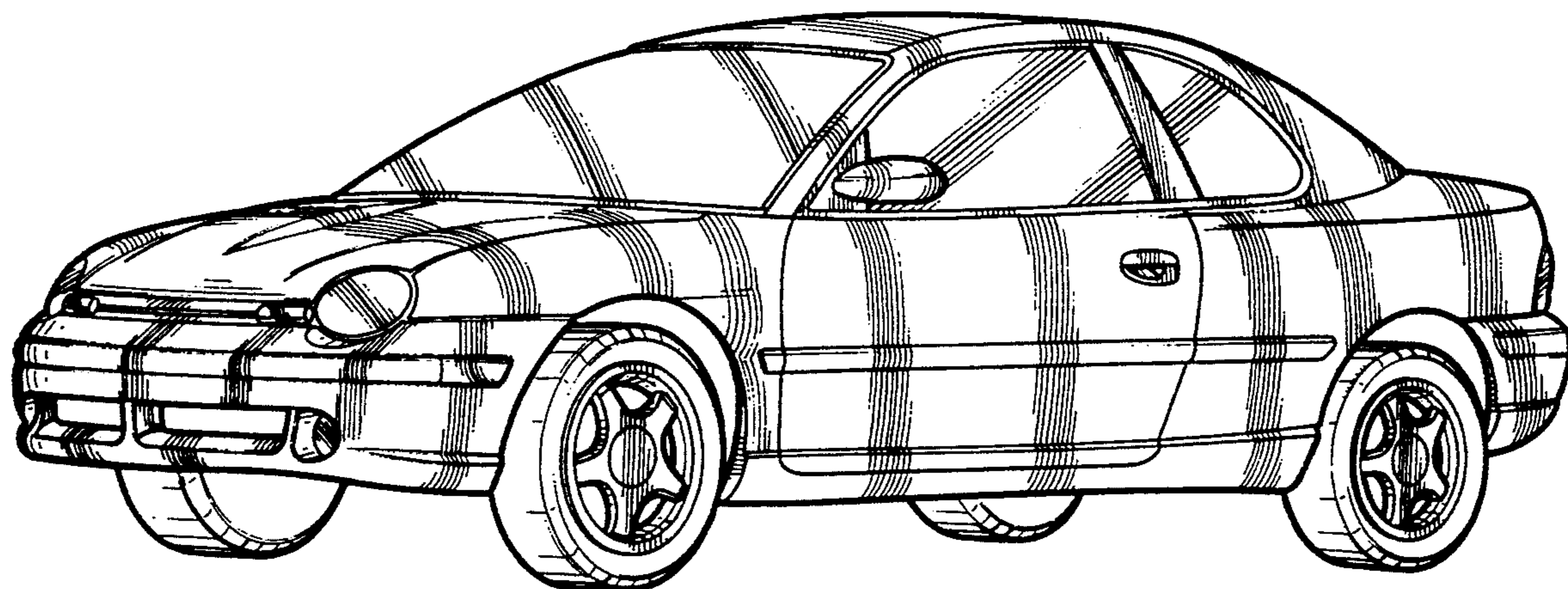

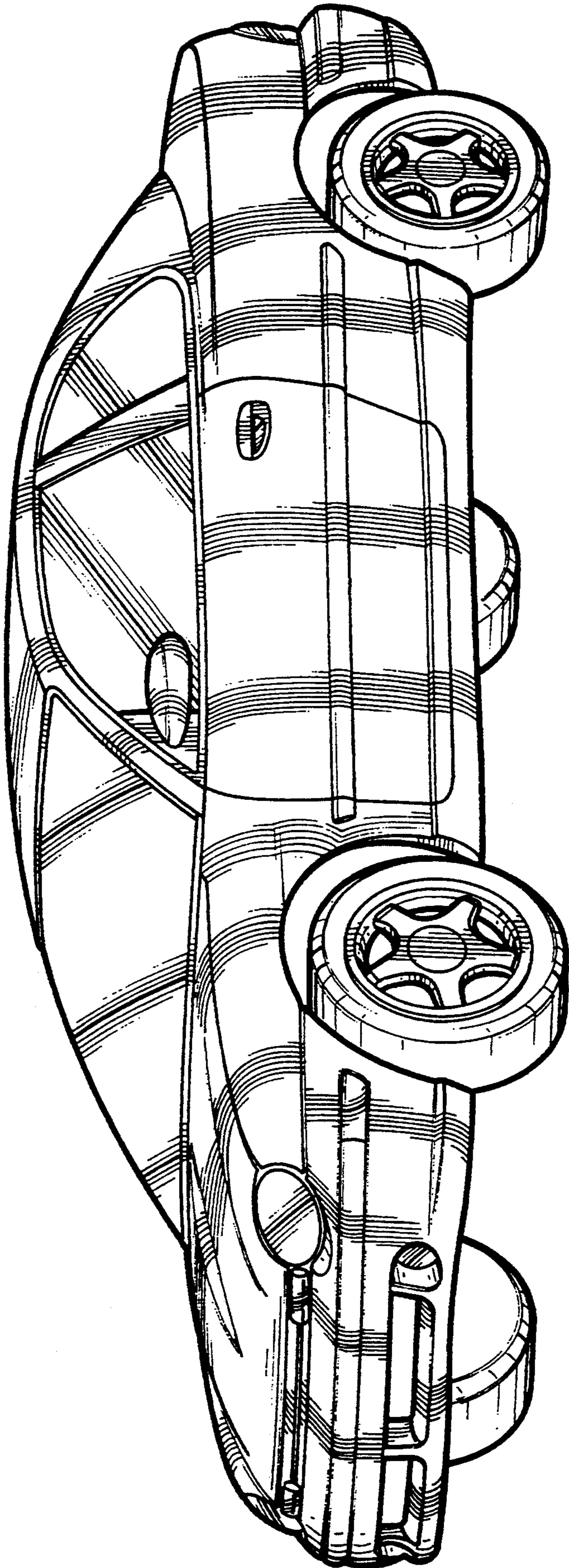

Fig-1

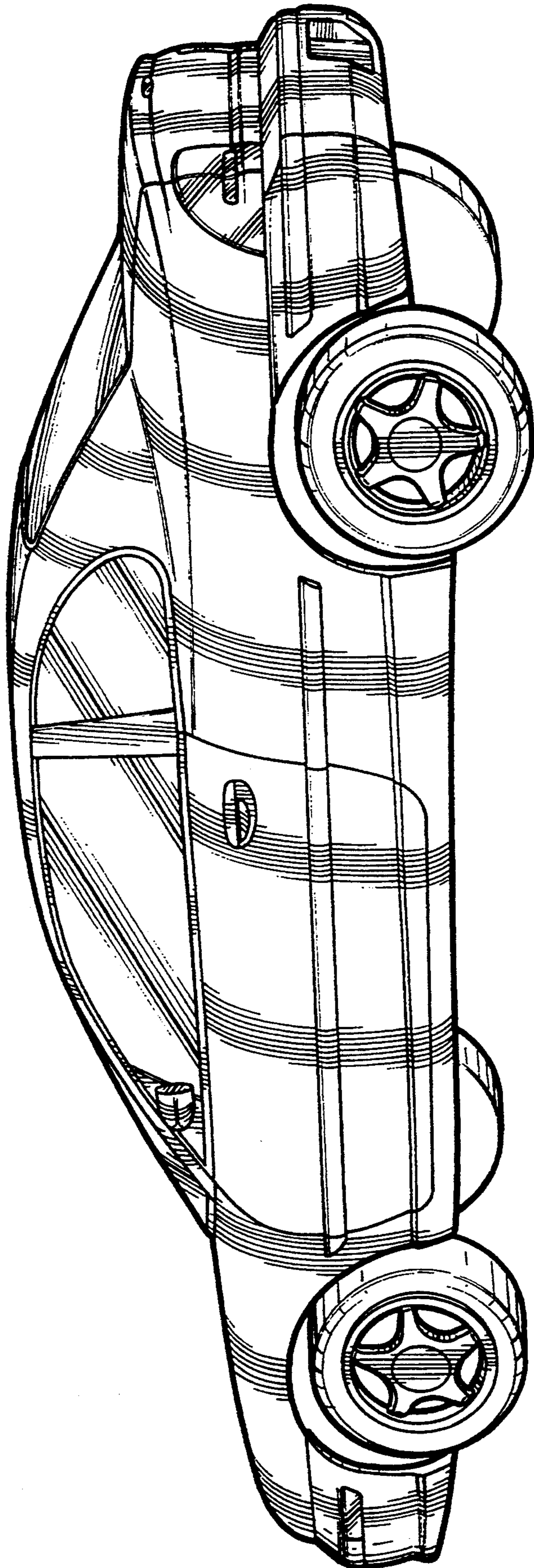

Fig-2

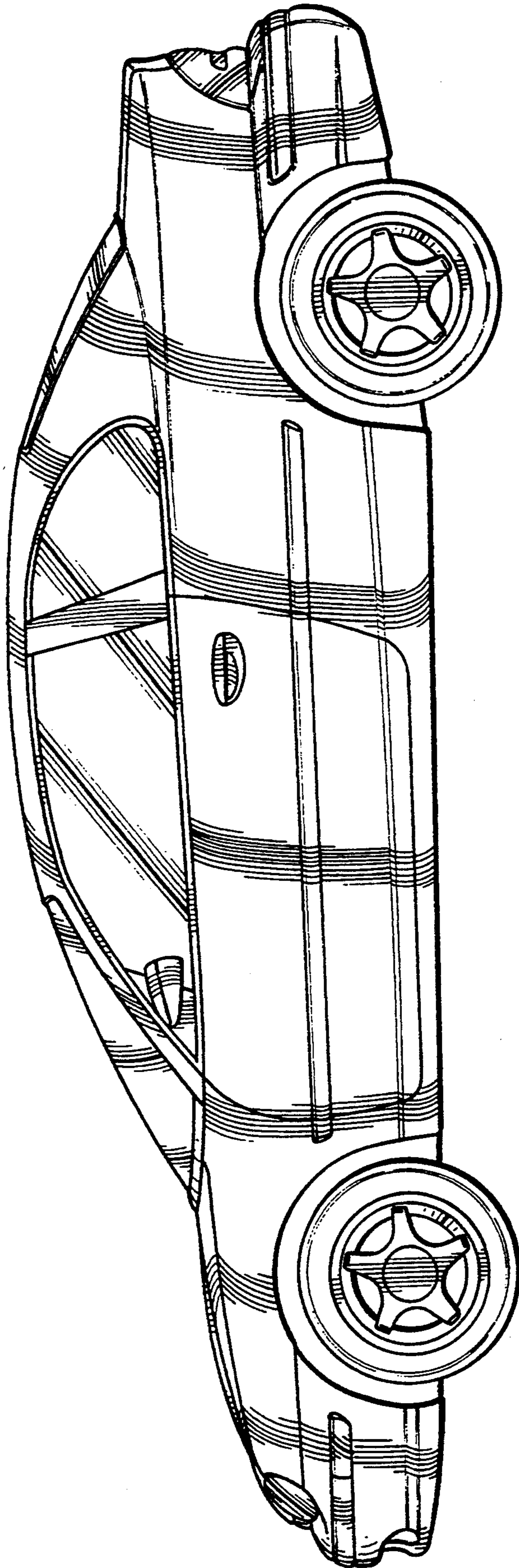

Fig-3

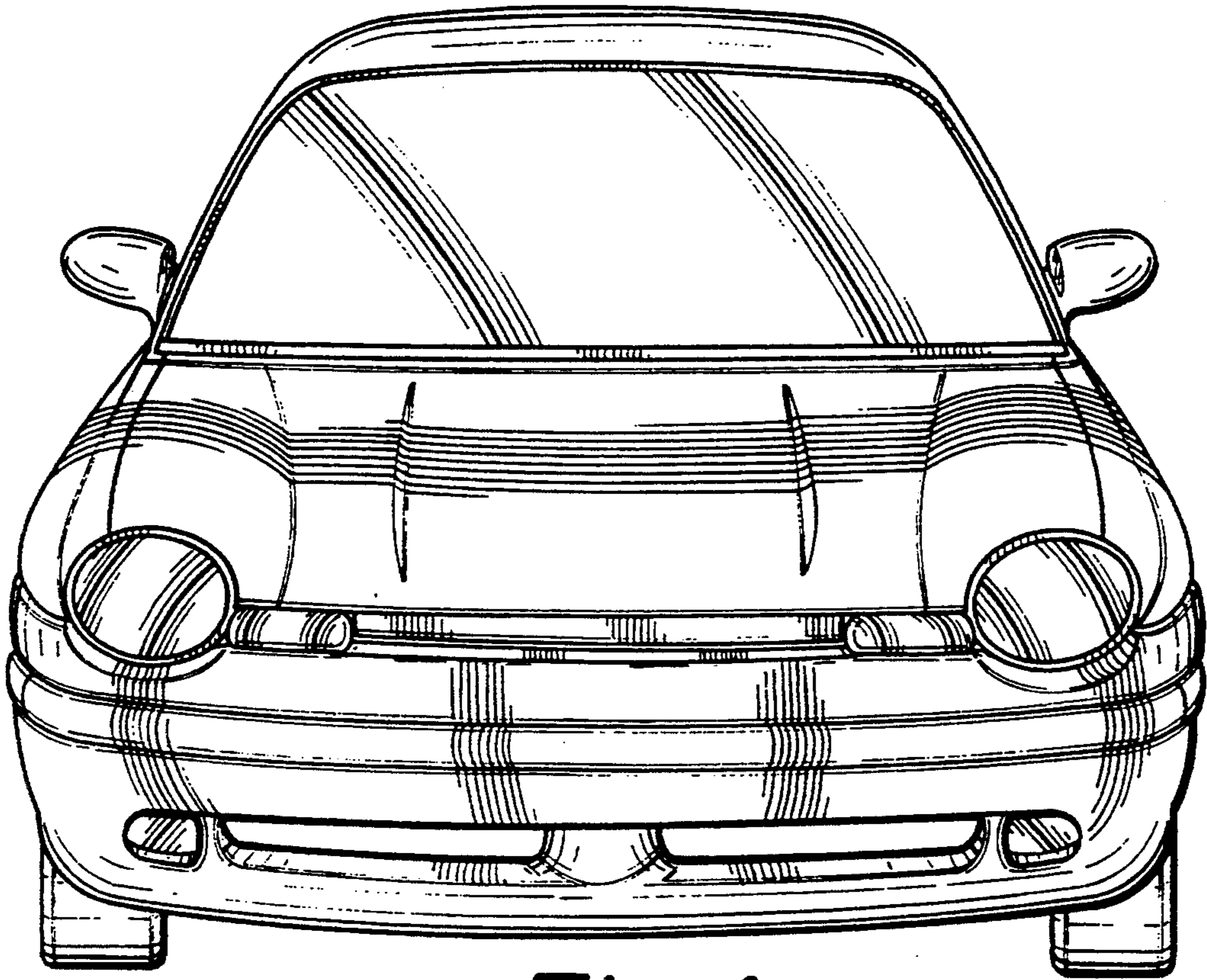

Fig-4

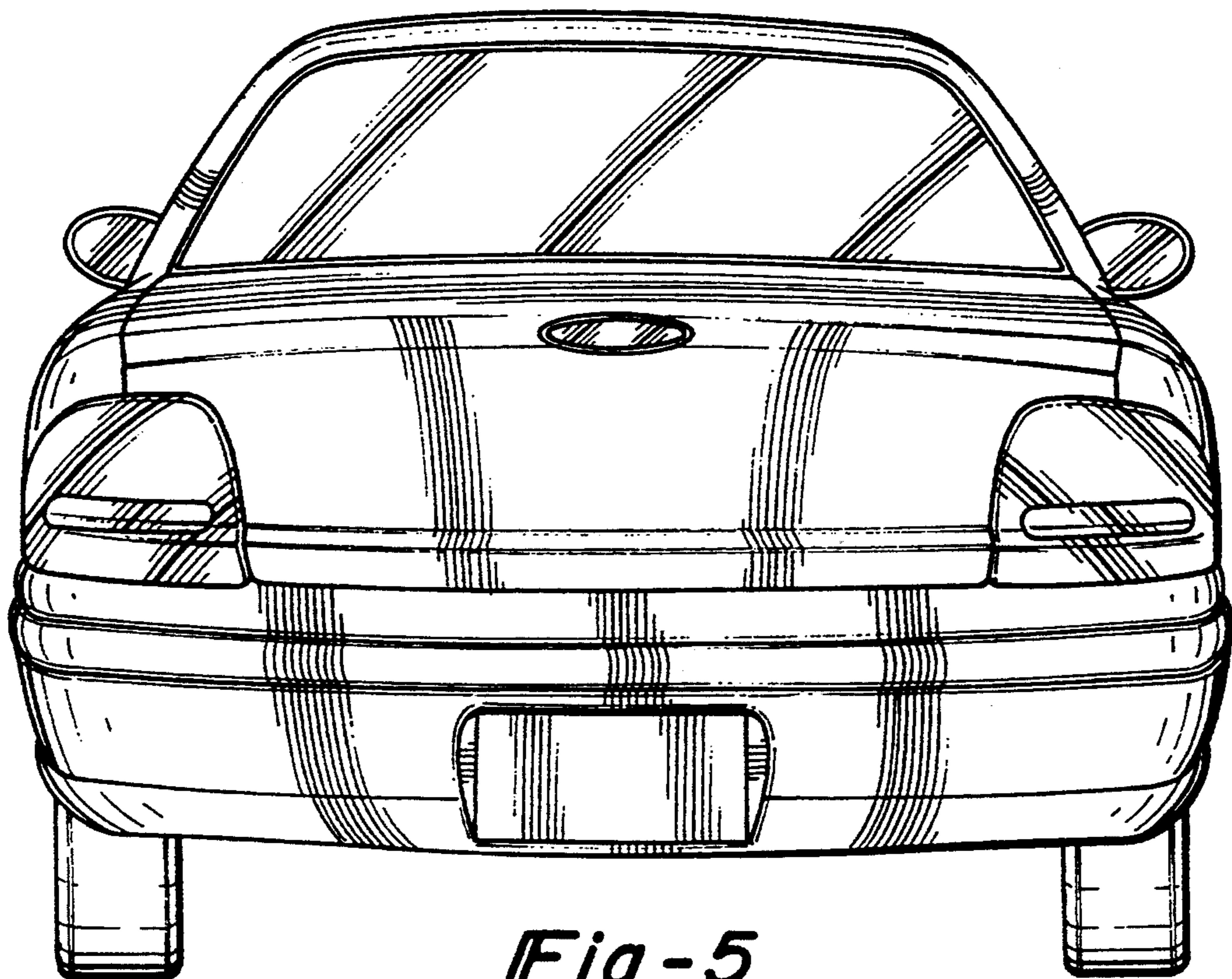

Fig-5

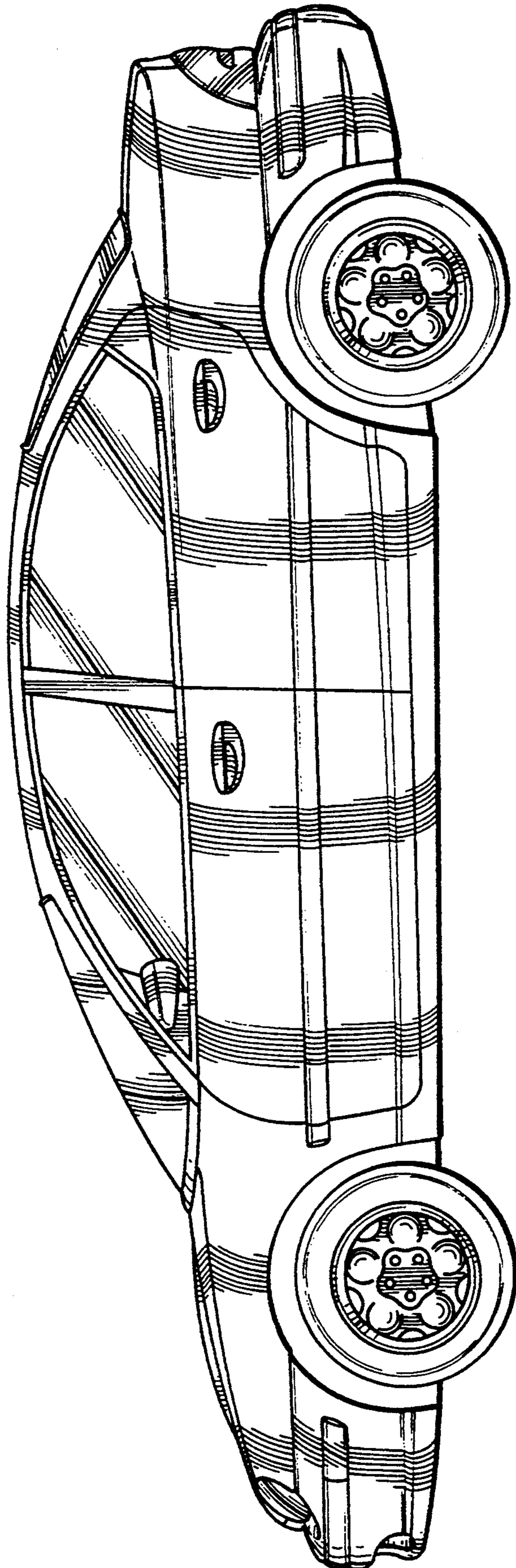

Fig - 6

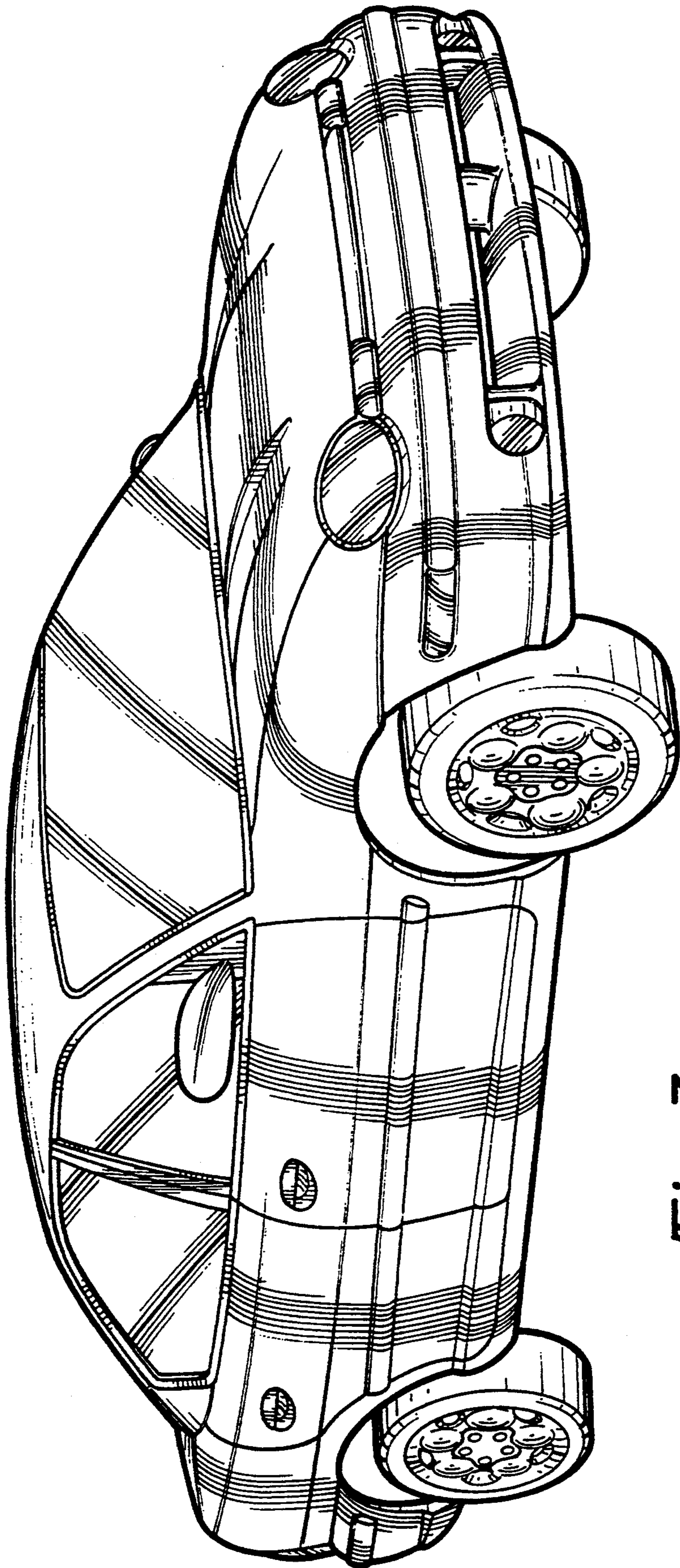

Fig-7

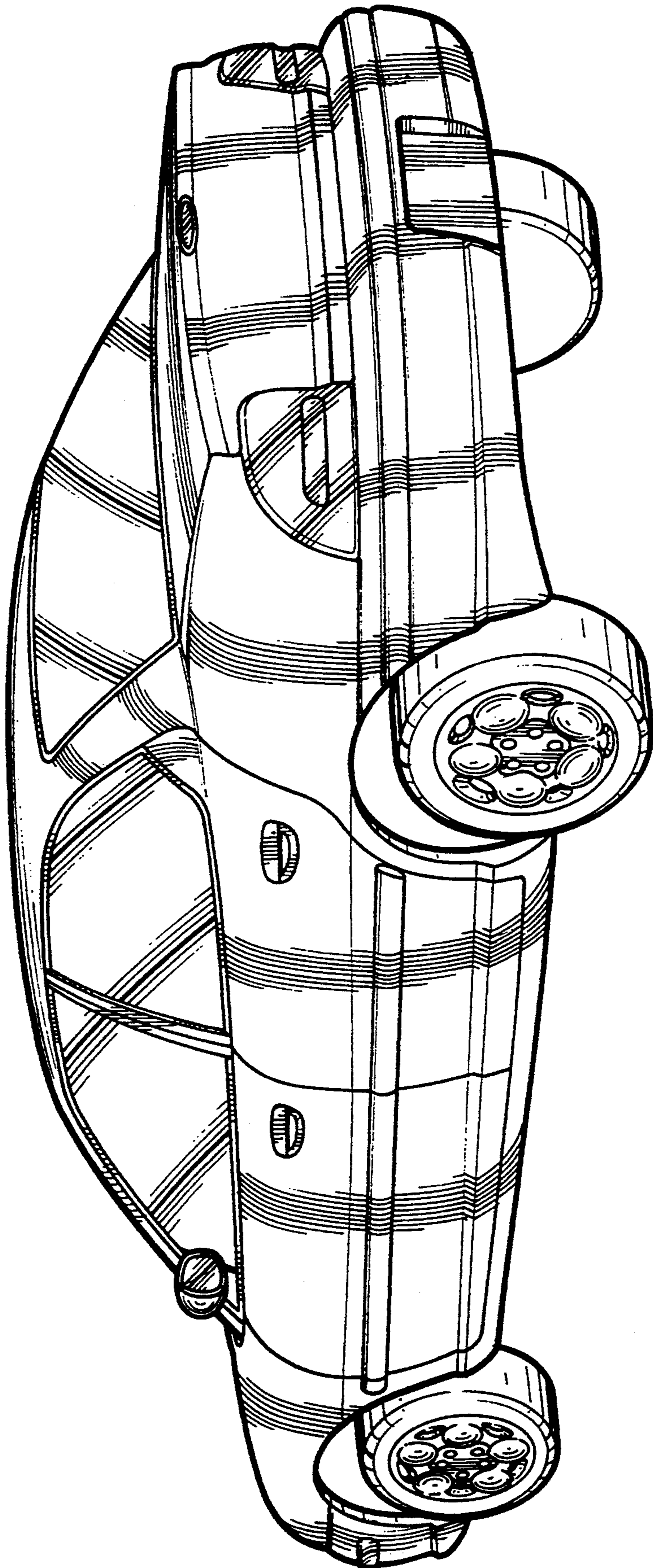

Fig-8