



US00D356697S

# United States Patent [19]

[11] Patent Number: **Des. 356,697**

**Kelly et al.**

[45] Date of Patent: **\*\* Mar. 28, 1995**

[54] SEAT  
[75] Inventors: **Gordon D. Kelly, Elm Grove; Glenn T. Walters, Port Washington, both of Wis.**

[73] Assignee: **Bemis Manufacturing Company, Sheboygan Falls, Wis.**

[ \* ] Notice: The portion of the term of this patent subsequent to Nov. 22, 2008 has been disclaimed.

[\*\*] Term: **14 Years**

[21] Appl. No.: **12,513**

[22] Filed: **Sep. 2, 1993**

[52] U.S. Cl. .... **D6/370; D6/381**

[58] Field of Search ..... **D6/334, 370, 374, 375, D6/379, 380, 381, 500, 501, 502; 297/411.41, 445, 446, DIG. 2**

[56] **References Cited**

**U.S. PATENT DOCUMENTS**

D. 262,077	12/1981	Deconinck	.....	D6/370
D. 303,591	9/1989	Grosfillex	.....	D6/370
D. 303,736	10/1989	Grosfillex	.....	D6/370 X
D. 311,461	10/1990	Lee et al.	.....	D6/370 X
D. 313,515	1/1991	Wood	.....	D6/370 X
D. 317,088	5/1991	Grosfillex	.....	D6/379
D. 325,304	4/1992	Grosfillex	.....	D6/370

D. 328,827	8/1992	Grosfillex	.....	D6/370
D. 330,291	10/1992	Grosfillex	.....	D6/370
D. 335,972	6/1993	Lamalle	.....	D6/370 X
D. 336,382	6/1993	Hubert	.....	D6/370
D. 338,347	8/1993	Hubert	.....	D6/370
D. 340,591	10/1993	Lamalle	.....	D6/370
D. 342,167	12/1993	Hess	.....	D6/370 X
5,044,691	9/1991	Guichon	.....	297/239
5,088,792	2/1992	Guichon	.....	297/445

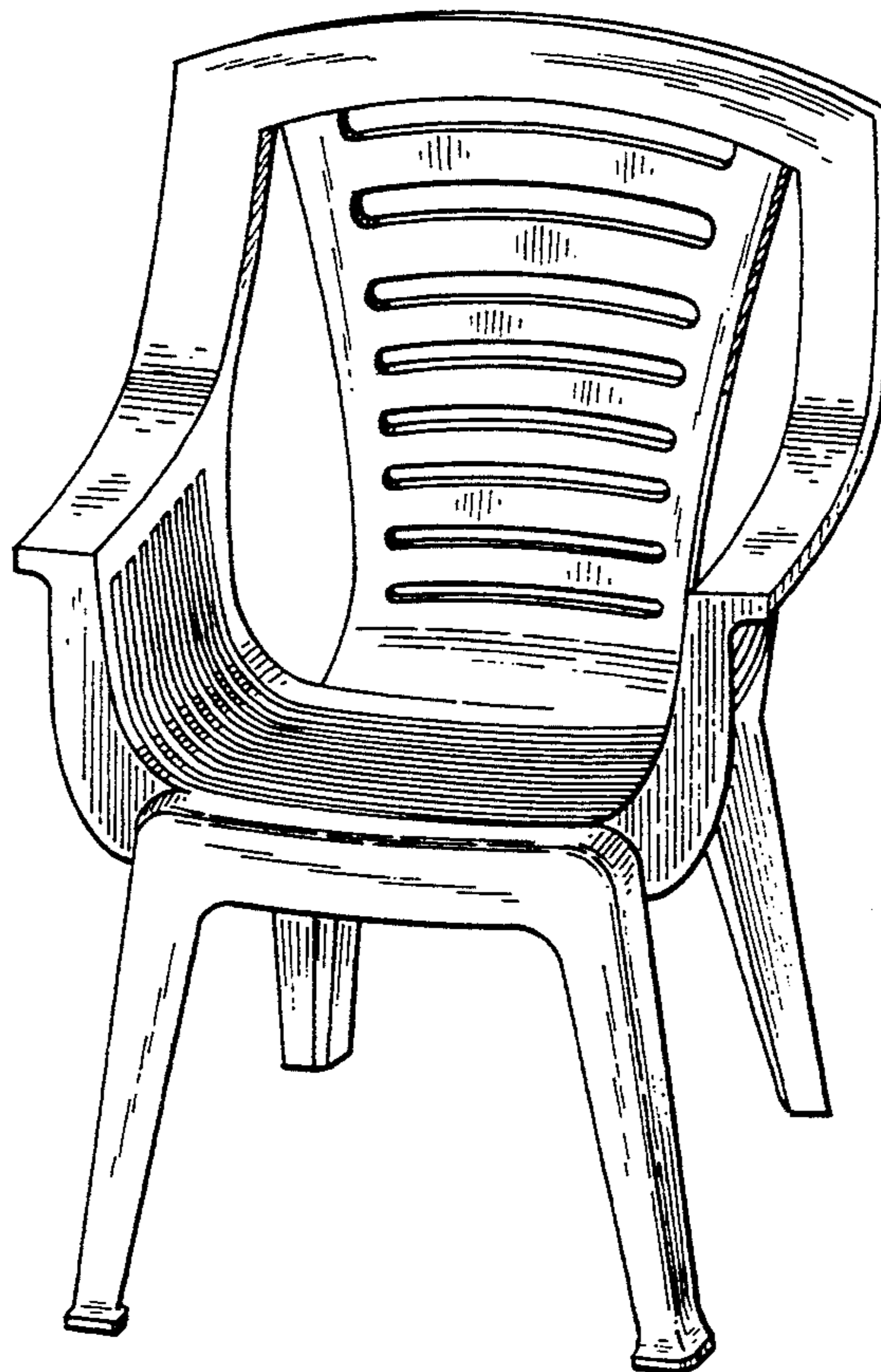
*Primary Examiner*—Alan P. Douglas  
*Assistant Examiner*—Gary D. Watson  
*Attorney, Agent, or Firm*—Michael, Best & Friedrich

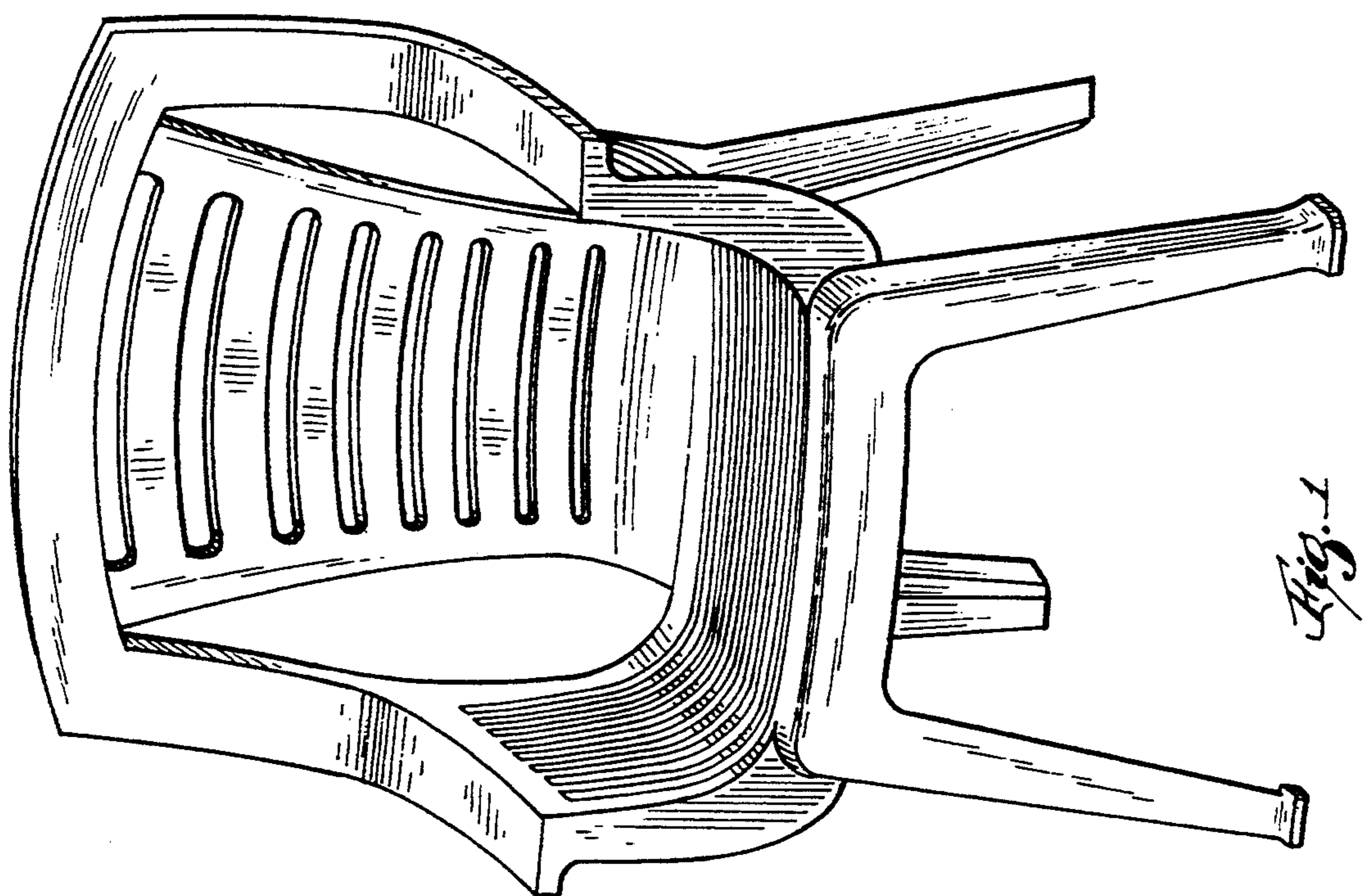
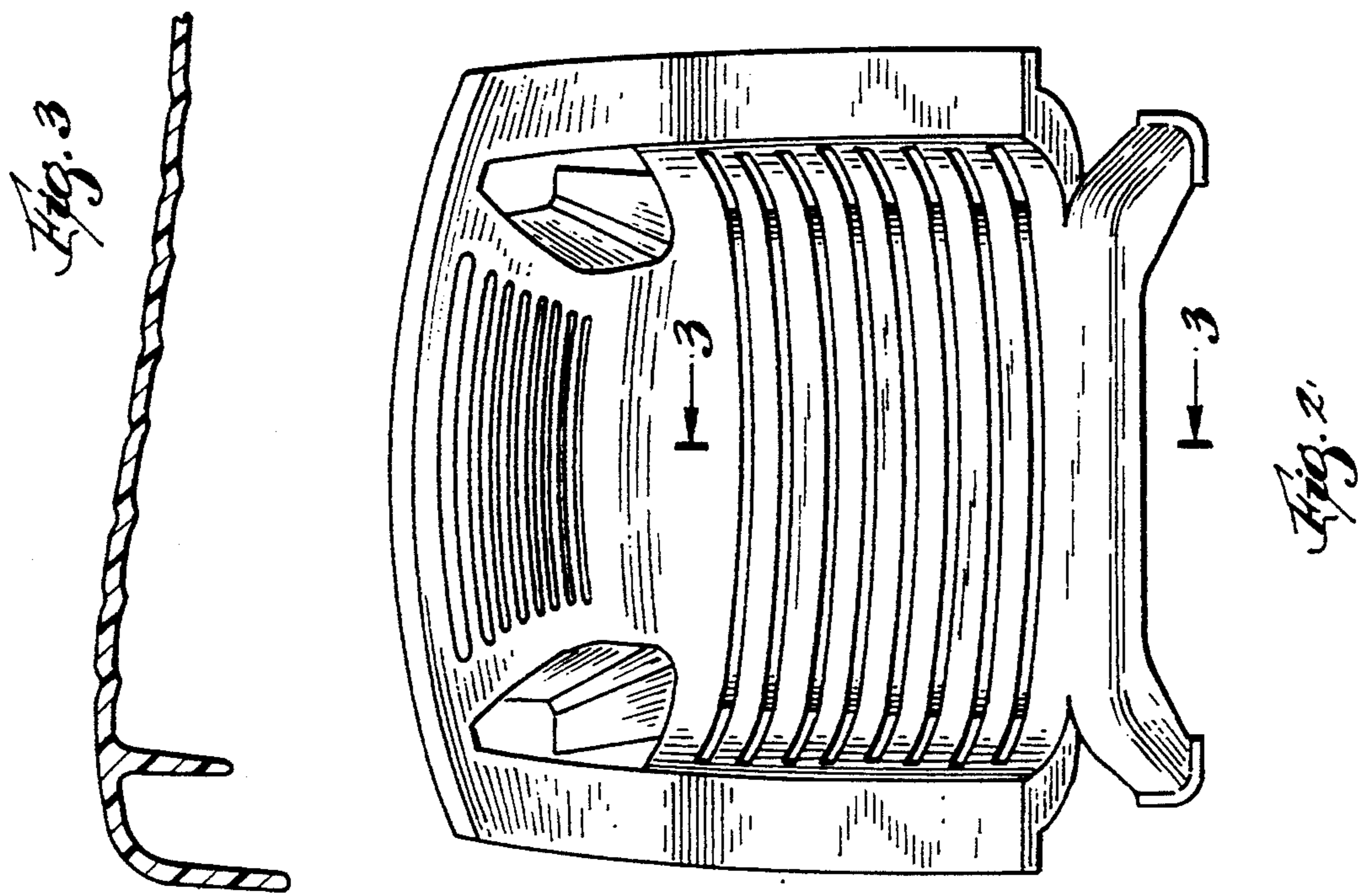
[57] **CLAIM**

The ornamental design for a seat, as shown and described.

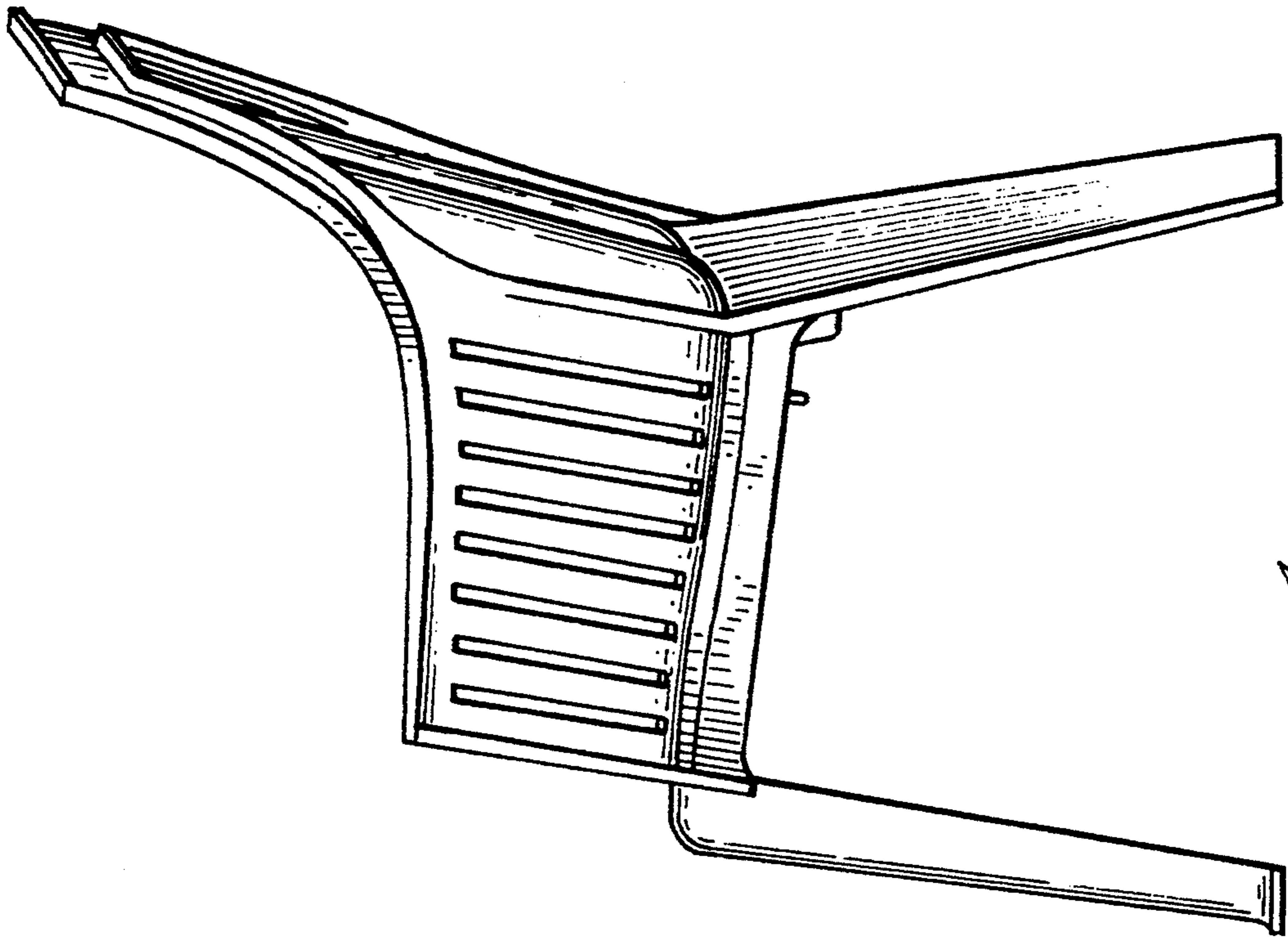
**DESCRIPTION**

FIG. 1 is a perspective view of a seat showing our new design;  
FIG. 2 is a top plan view thereof;  
FIG. 3 is a view taken along line 3—3 in FIG. 2;  
FIG. 4 is a right side elevational view thereof, the left side view being a mirror image of that shown;  
FIG. 5 is a front elevational view thereof;  
FIG. 6 is a bottom plan view thereof;  
FIG. 7 is a rear elevational view thereof; and,  
FIG. 8 is a perspective view of a seat showing a second embodiment of my new design in the form of a love seat.

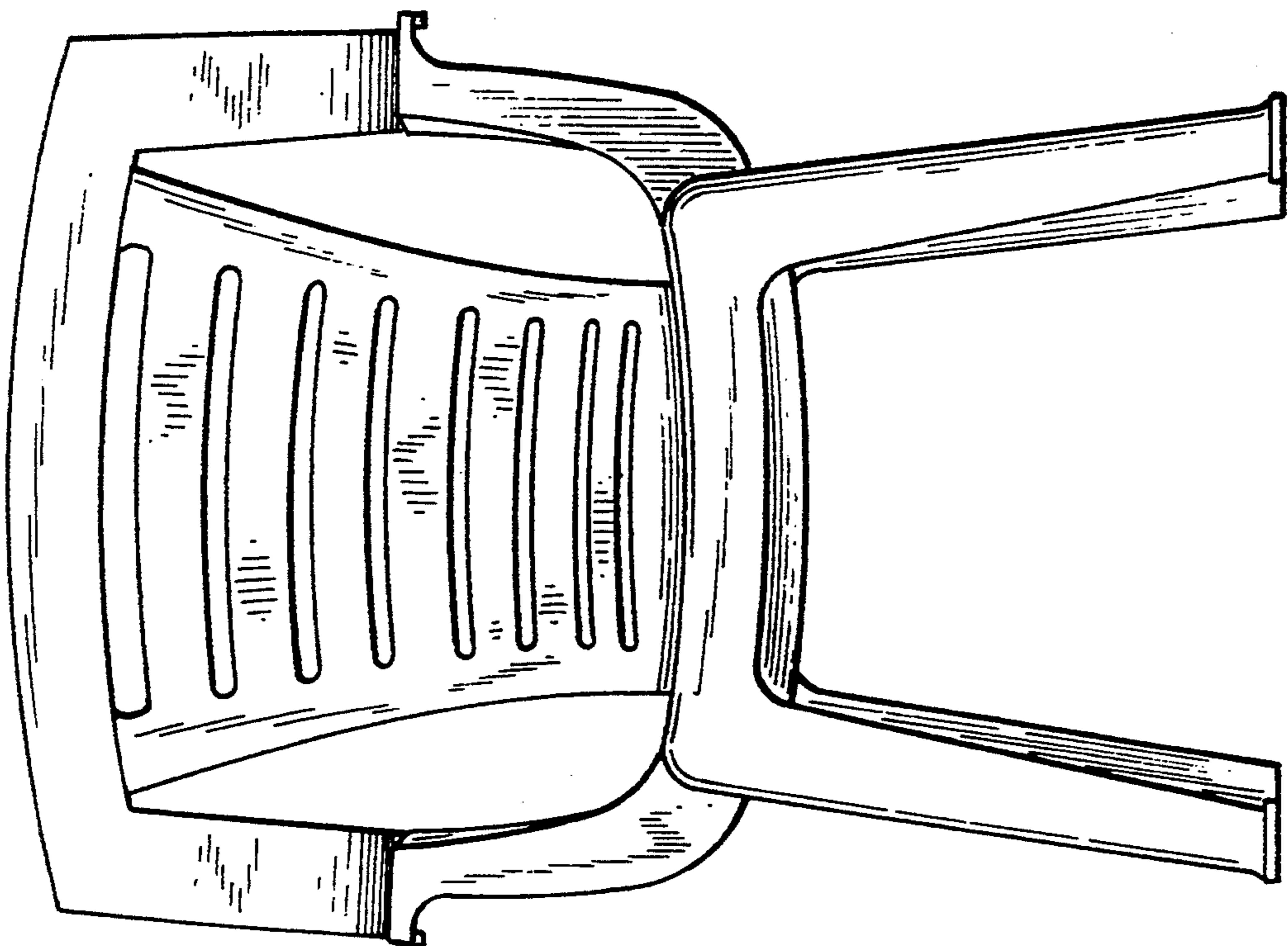




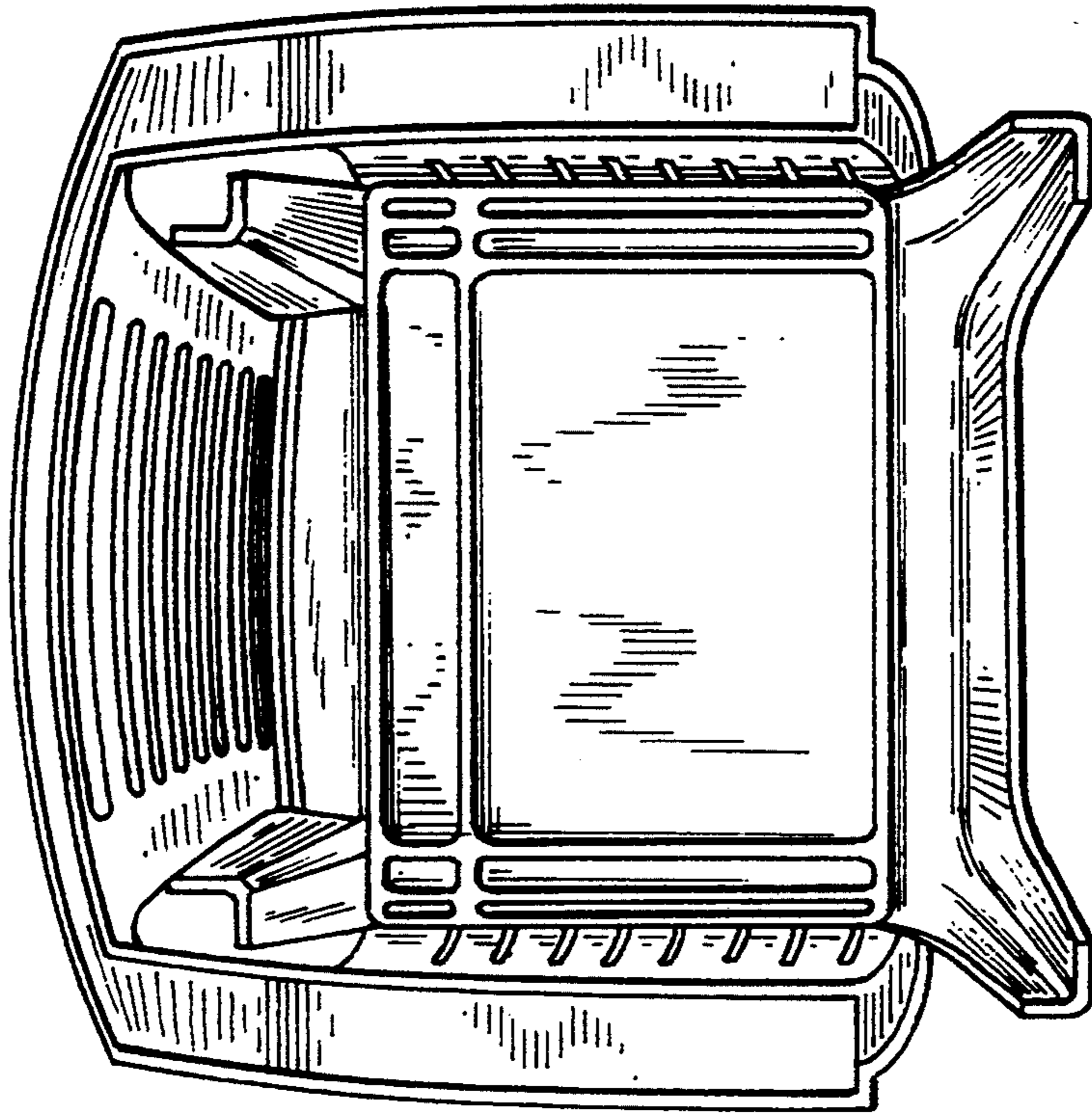




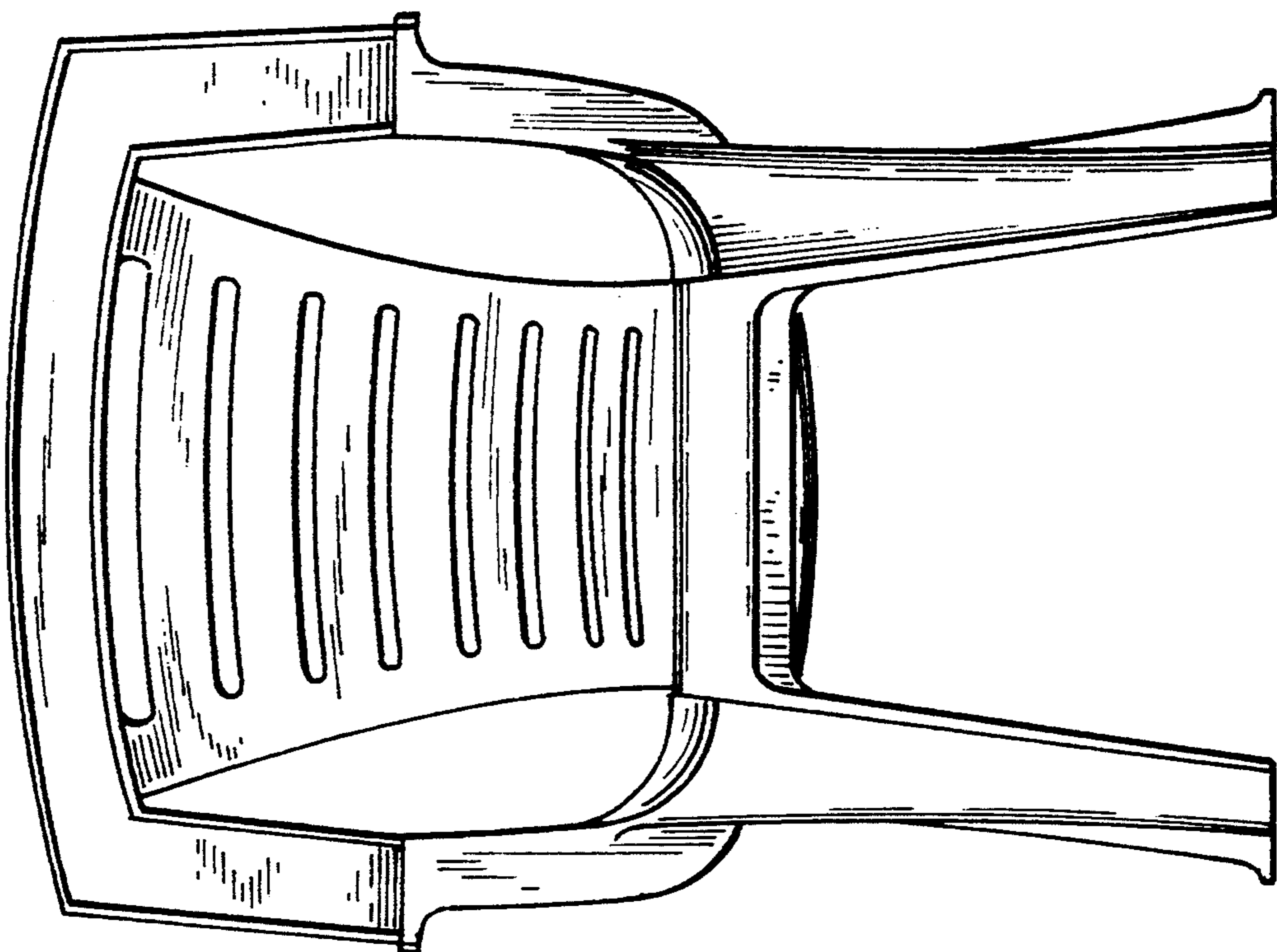
*Fig. 4*



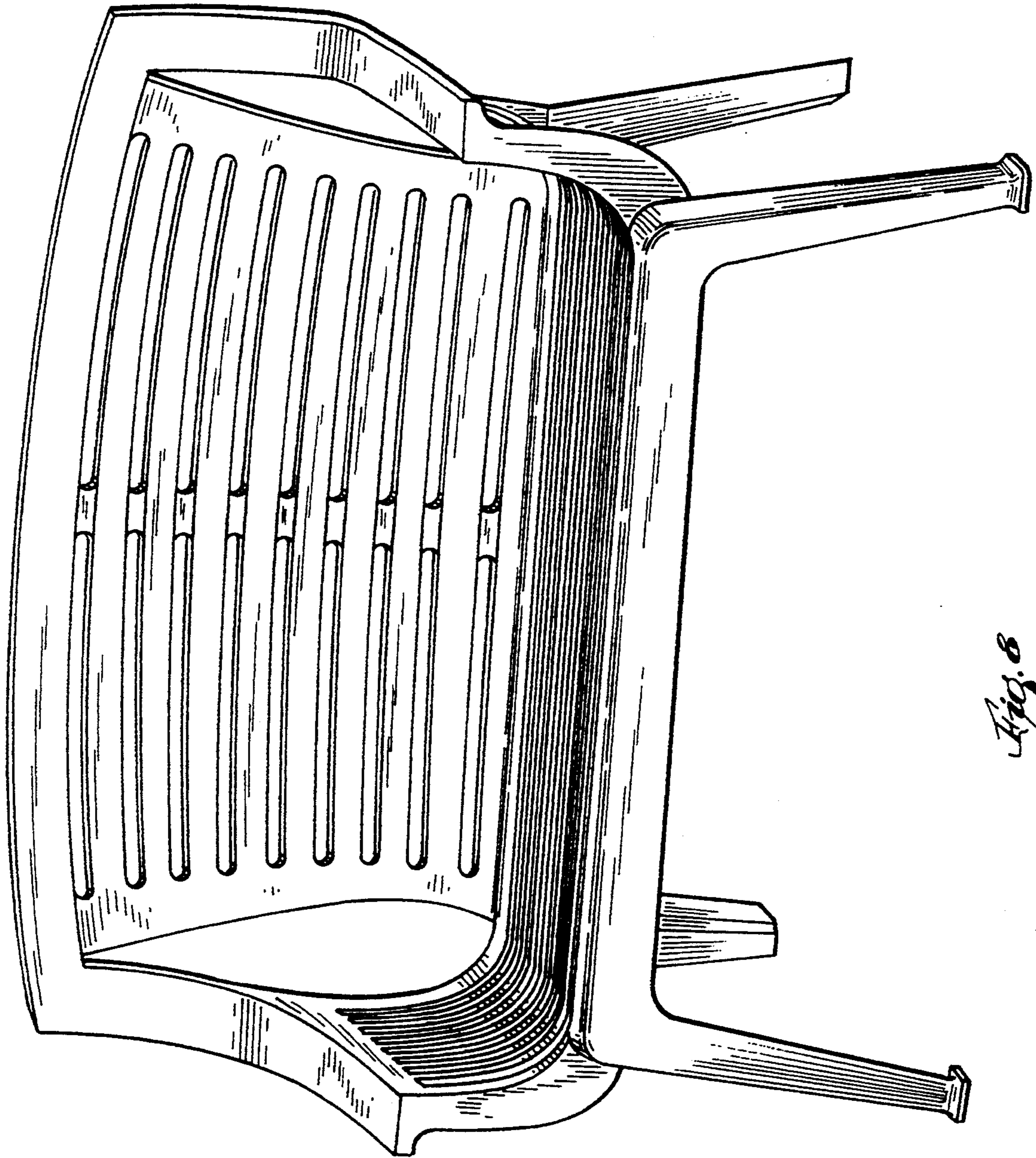
*Fig. 5*



*Fig. 6*



*Fig. 7*



*Fig. 8*