



US00D356487S

# United States Patent [19]

[11] Patent Number: **Des. 356,487**

Huang

[45] Date of Patent: **\*\* Mar. 21, 1995**

[54] **AUTOMOBILE STEERING LOCK**

4,856,308 6/1989 Johnson ..... 70/209

[76] Inventor: **E-Tao Huang**, No. 68, Lane 27,  
Section 6, Fu-An Road, Tainan,  
Taiwan, Prov. of China

*Primary Examiner*—Brian N. Vinson

[\*\*] Term: **14 Years**

[57] **CLAIM**

The ornamental design for automobile steering lock, as shown and described.

[21] Appl. No.: **18,845**

**DESCRIPTION**

[22] Filed: **Feb. 16, 1994**

[52] U.S. Cl. .... **D8/341; D8/331**

[58] Field of Search ..... **D8/330-331,**  
**D8/339, 341; 70/207-211, 214-215, 225-226,**  
**237-238; 292/289**

FIG. 1 is a top, front, and right side perspective view of automobile steering lock showing my new design;  
FIG. 2 is a front elevational view thereof;  
FIG. 3 is a rear elevational view thereof;  
FIG. 4 is a left elevational view thereof;  
FIG. 5 is a right elevational view thereof;  
FIG. 6 is a top plan view thereof;  
FIG. 7 is a bottom plan view thereof; and,  
FIG. 8 is a reduced top, front, and right side perspective view thereof, with the broken-line disclosure of a portion of a steering wheel and dashboard being shown for illustrative purposes only and forming no part of the claimed design.

[56] **References Cited**

**U.S. PATENT DOCUMENTS**

D. 328,020	7/1992	Wang	.....	D8/331	X
D. 339,734	9/1993	Chen et al.	.....	D8/331	
D. 342,886	1/1994	Su	.....	D8/331	
4,304,110	1/1981	Fain	.....	70/209	

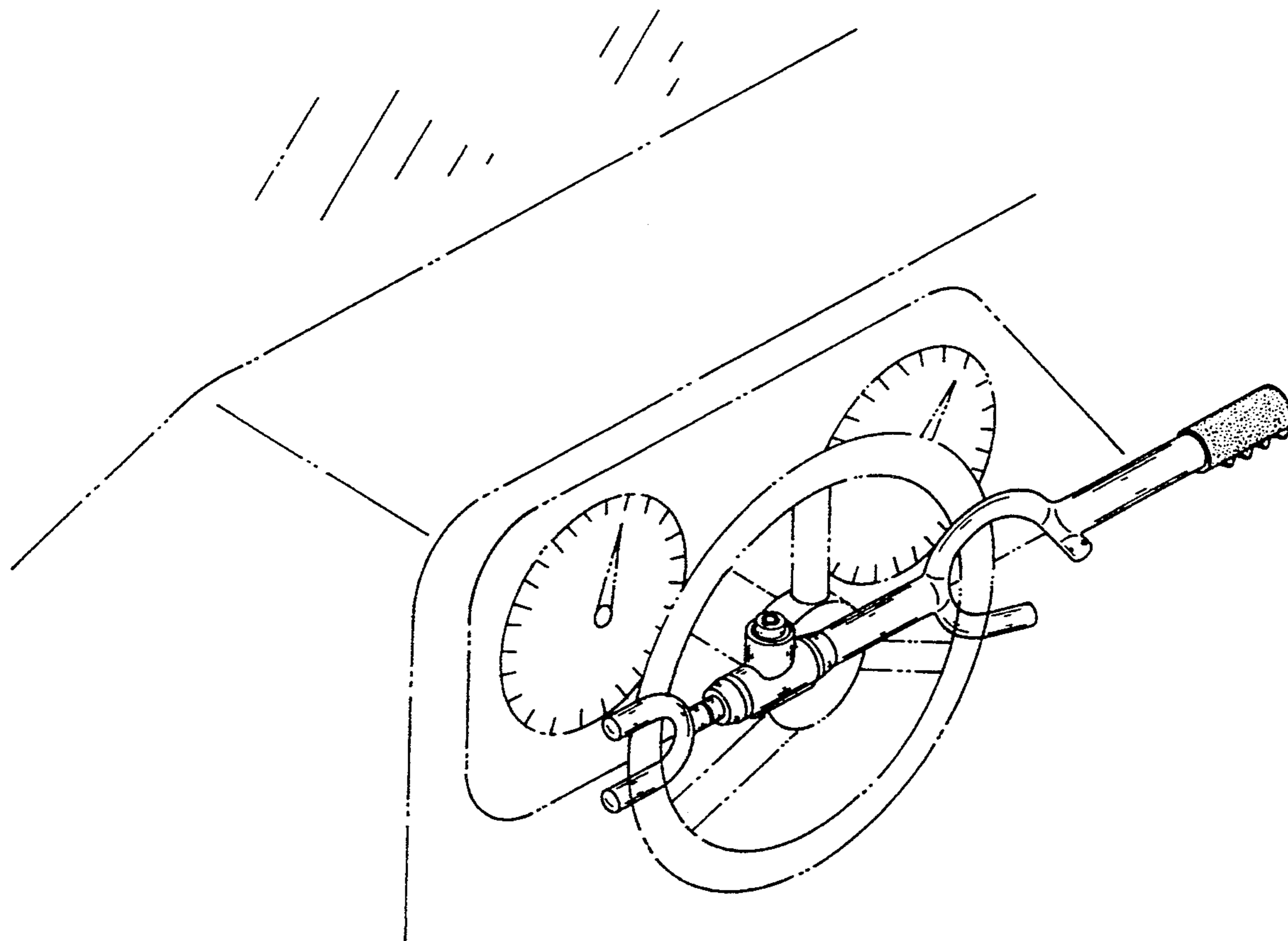

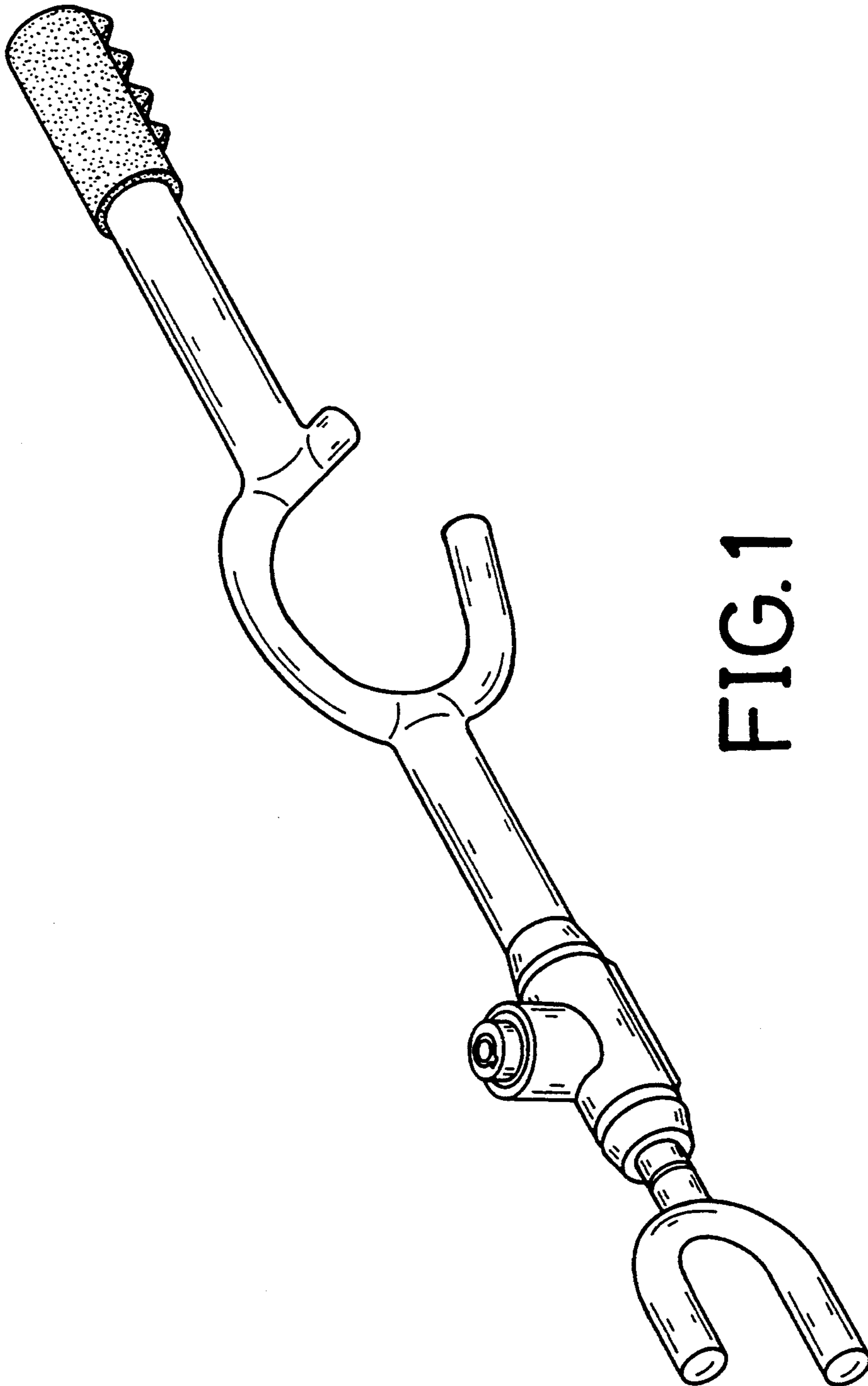

FIG. 1

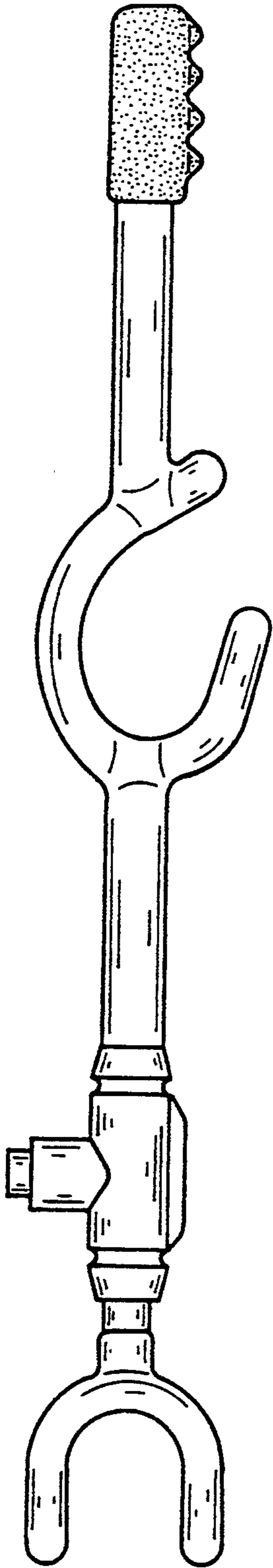

FIG. 2

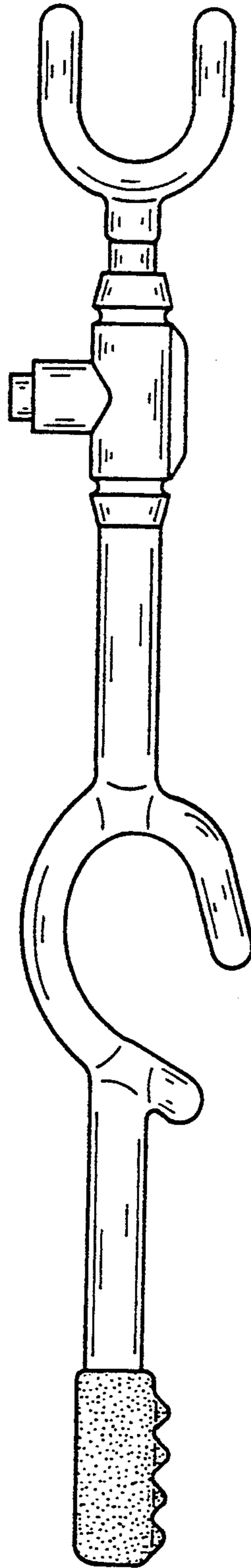

FIG. 3

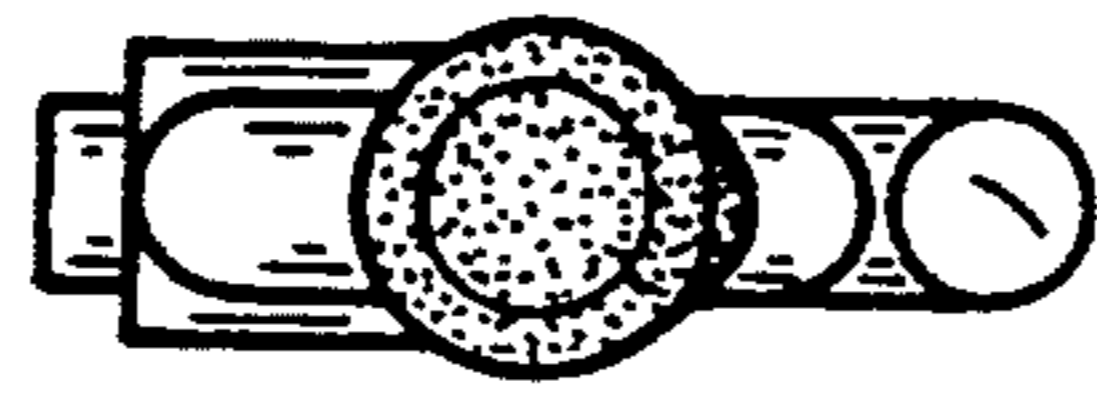

FIG. 5



FIG. 4

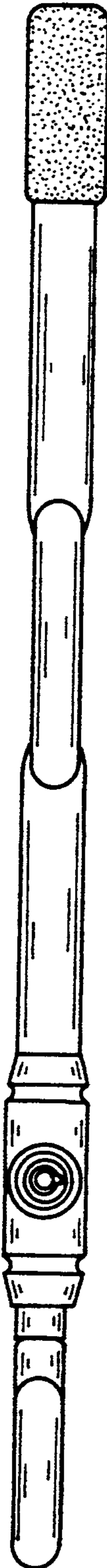

FIG. 6

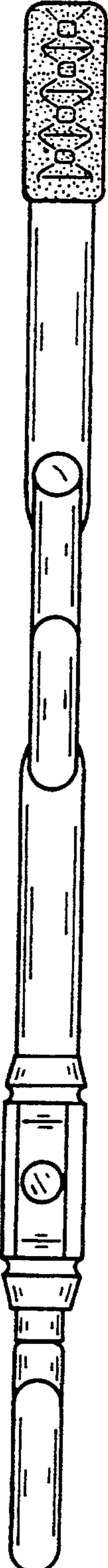

FIG. 7

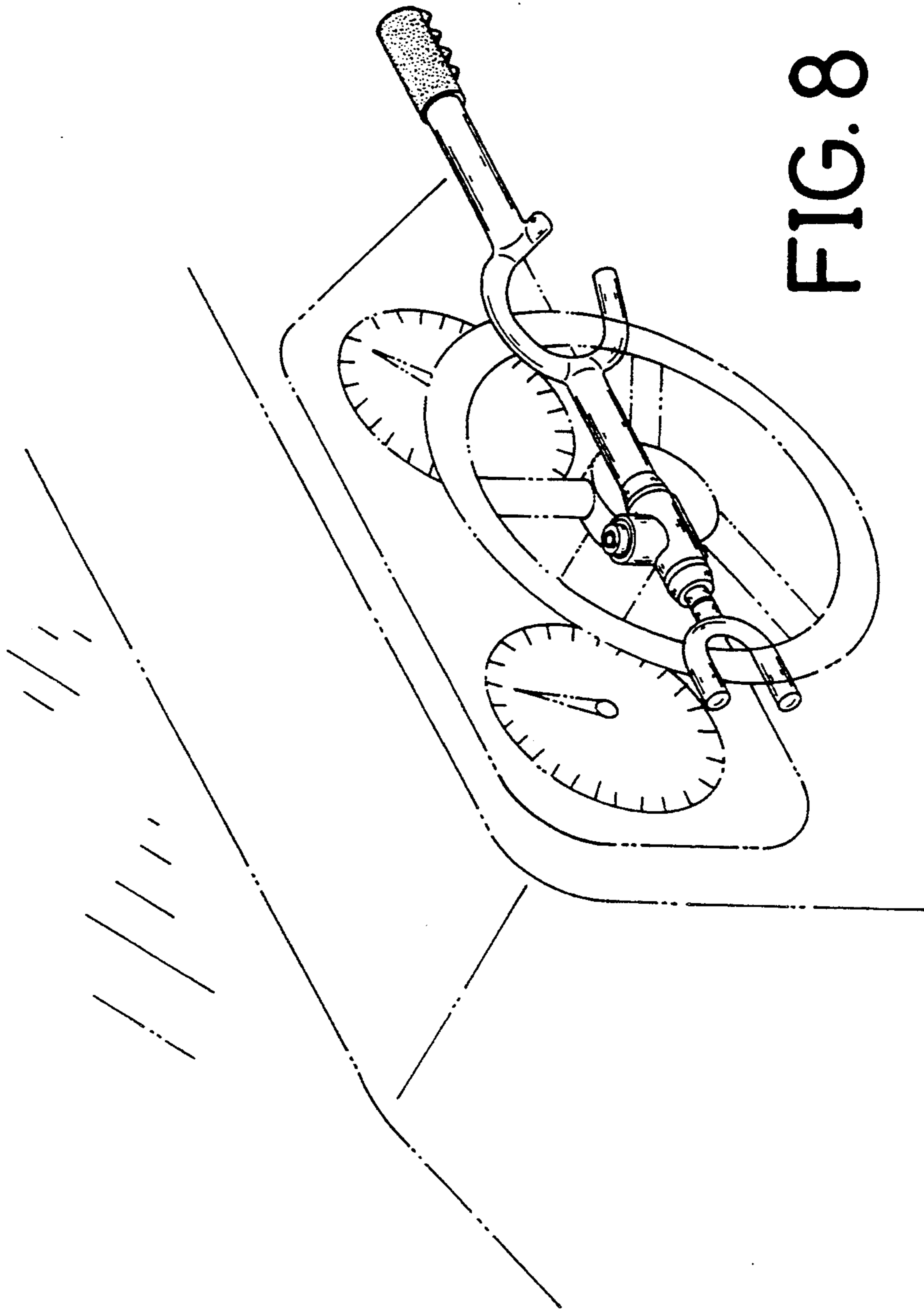

FIG. 8