



US00D356447S

United States Patent [19]

[11] Patent Number: **Des. 356,447**

Peters

[45] Date of Patent: **** Mar. 21, 1995**

[54] **CHILD BIKE SEAT**

0390332 10/1990 European Pat. Off. .
3206935 10/1982 Germany .
457219 11/1936 United Kingdom .
2097345 11/1982 United Kingdom .

[75] Inventor: **Wolfram Peters**, Leiden, Netherlands

[73] Assignee: **Hamax AS**, Norway

[**] Term: **14 Years**

[21] Appl. No.: **19,262**

[22] Filed: **Feb. 28, 1994**

OTHER PUBLICATIONS

Sears-Fall/Winter 1975, p. 1240, seat at top left.

Primary Examiner—Janice E. Seeger

Attorney, Agent, or Firm—Andrus, Scales, Starke & Sawall

Related U.S. Application Data

[62] Division of Ser. No. 184, Oct. 6, 1992.

[52] U.S. Cl. **D6/333**

[58] Field of Search D6/331, 333, 339, 334;
5/655; 297/250.1, 216.11, 255, 256.12, 256.16,
195.13, 243

[57] CLAIM

The ornamental design for a child bike seat, as shown and described.

[56] References Cited

U.S. PATENT DOCUMENTS

D. 225,294 12/1972 Day D6/375
D. 294,203 2/1988 Schepis et al. D6/354
D. 332,877 2/1993 Newbold D6/333
D. 337,665 7/1993 Tsuchiya D6/339
3,802,598 4/1974 Burger et al. .
3,922,035 11/1975 Wener D6/333
4,051,985 10/1977 Berger .

DESCRIPTION

FIG. 1 is a perspective view of a child bike seat, showing my new design;
FIG. 2 is a bottom plan view thereof;
FIG. 3 is a front elevational view thereof;
FIG. 4 is a side elevational view, the opposite side being a mirror image thereof;
FIG. 5 is a rear elevational view thereof;
FIG. 6 is a top plan view thereof;
FIG. 7 is a perspective view of a child bike seat, showing a second embodiment of my new design;
FIG. 8 is a bottom plan view thereof;
FIG. 9 is a front elevational view thereof;
FIG. 10 is a side elevational view, the opposite side being a mirror image thereof;
FIG. 11 is a rear elevational view thereof; and,
FIG. 12 is a top plan view thereof.

FOREIGN PATENT DOCUMENTS

1213510 11/1986 Canada .
0232800 8/1987 European Pat. Off. .
0347005 12/1989 European Pat. Off. .

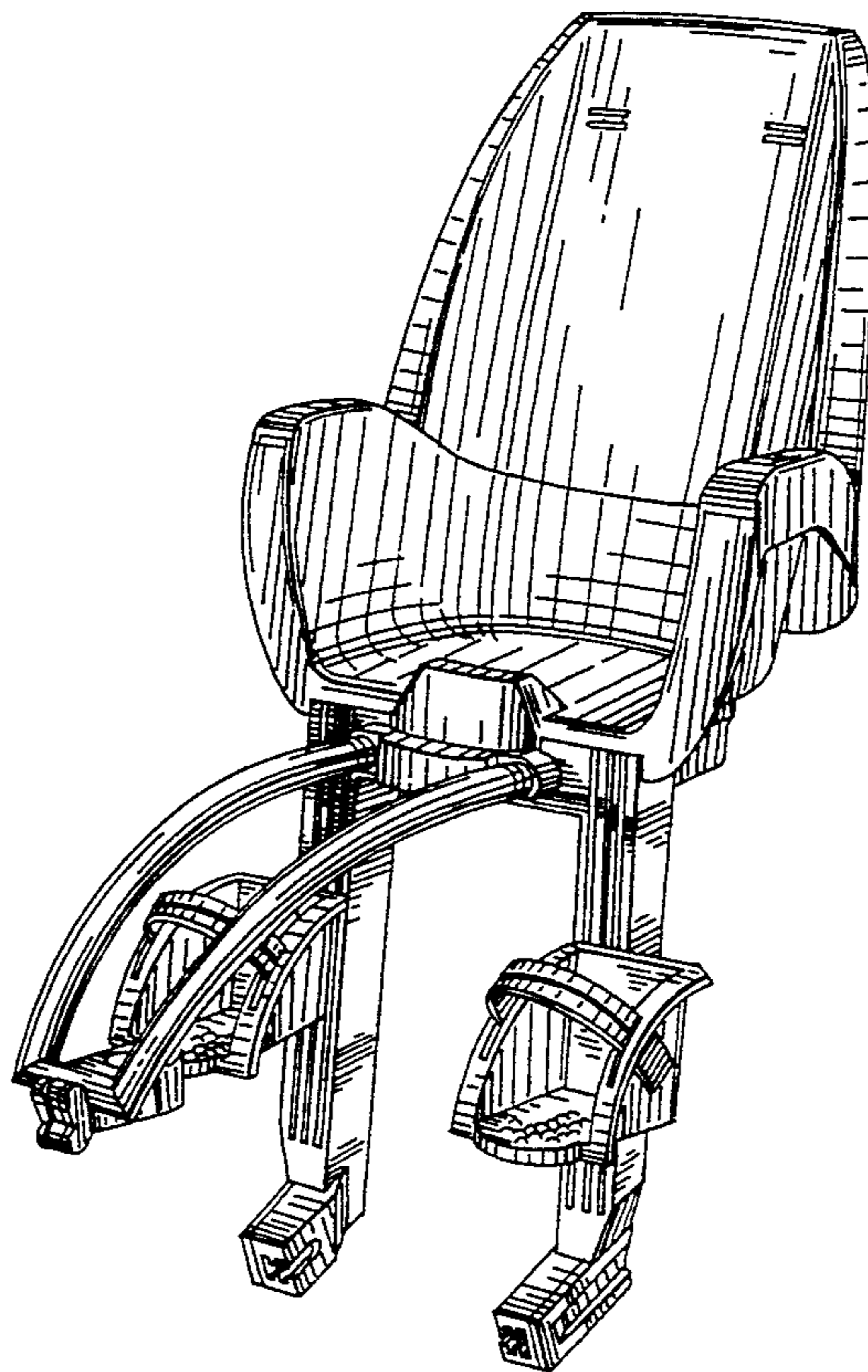

FIG. 1

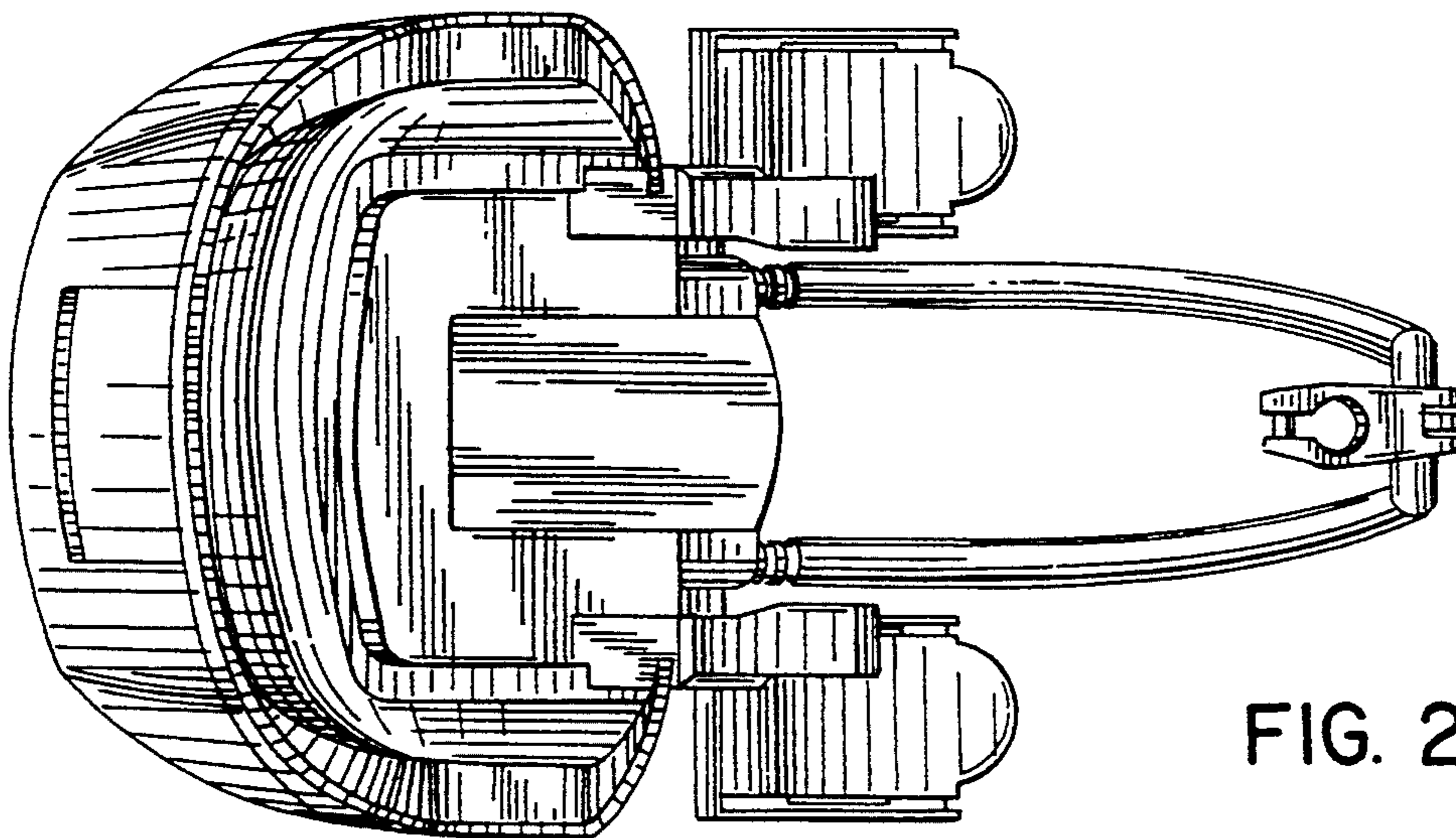
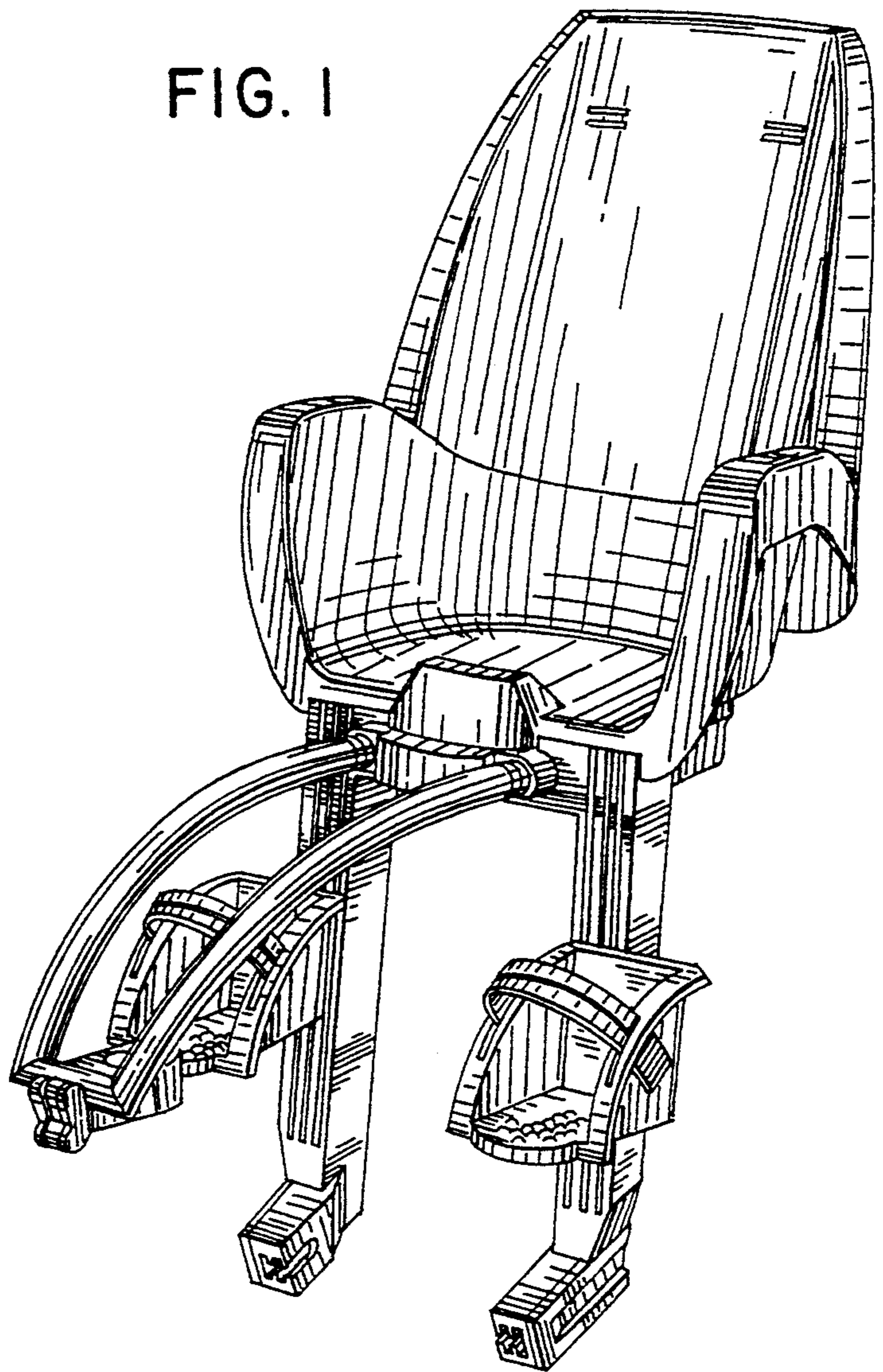

FIG. 2

FIG. 3

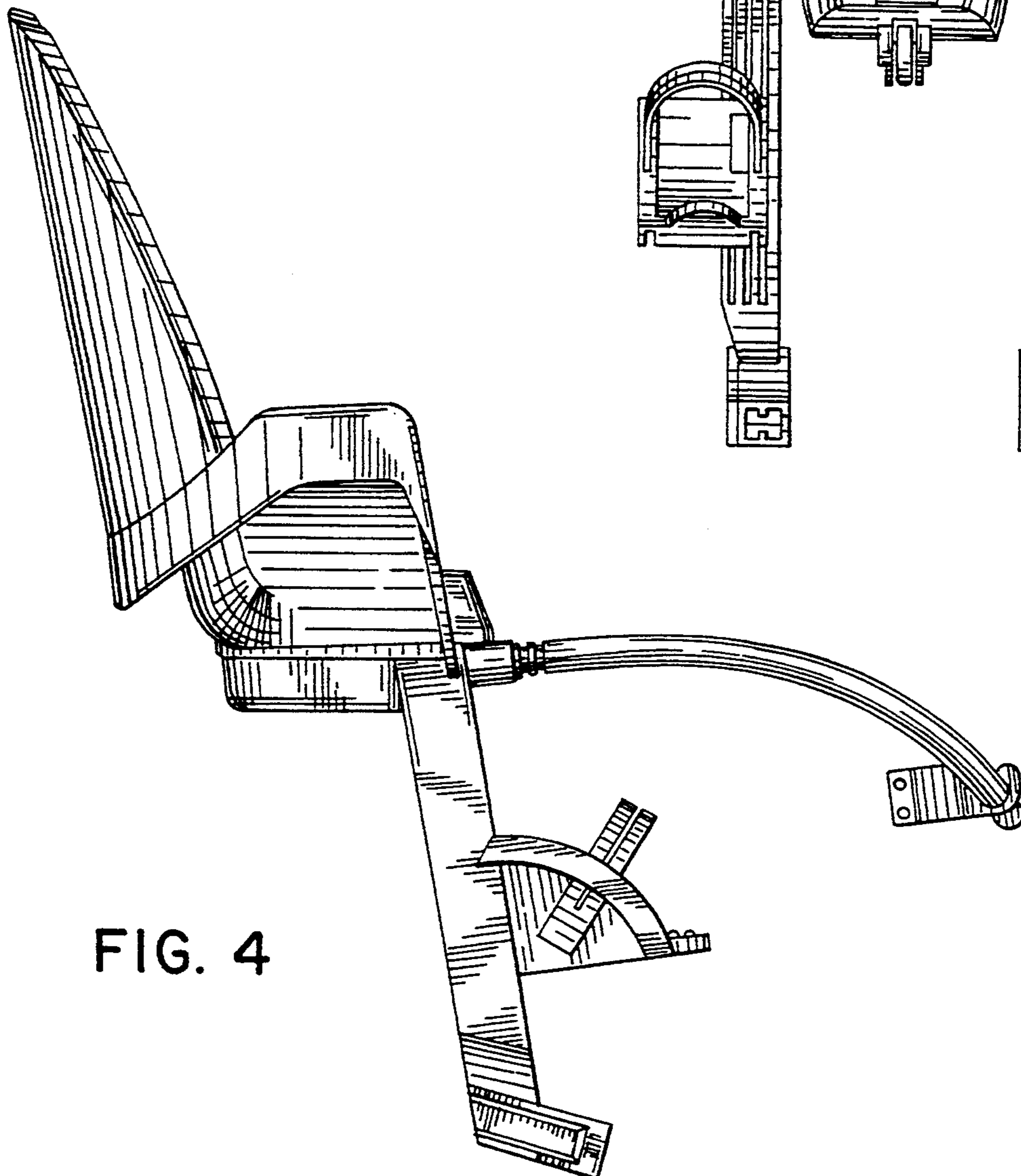
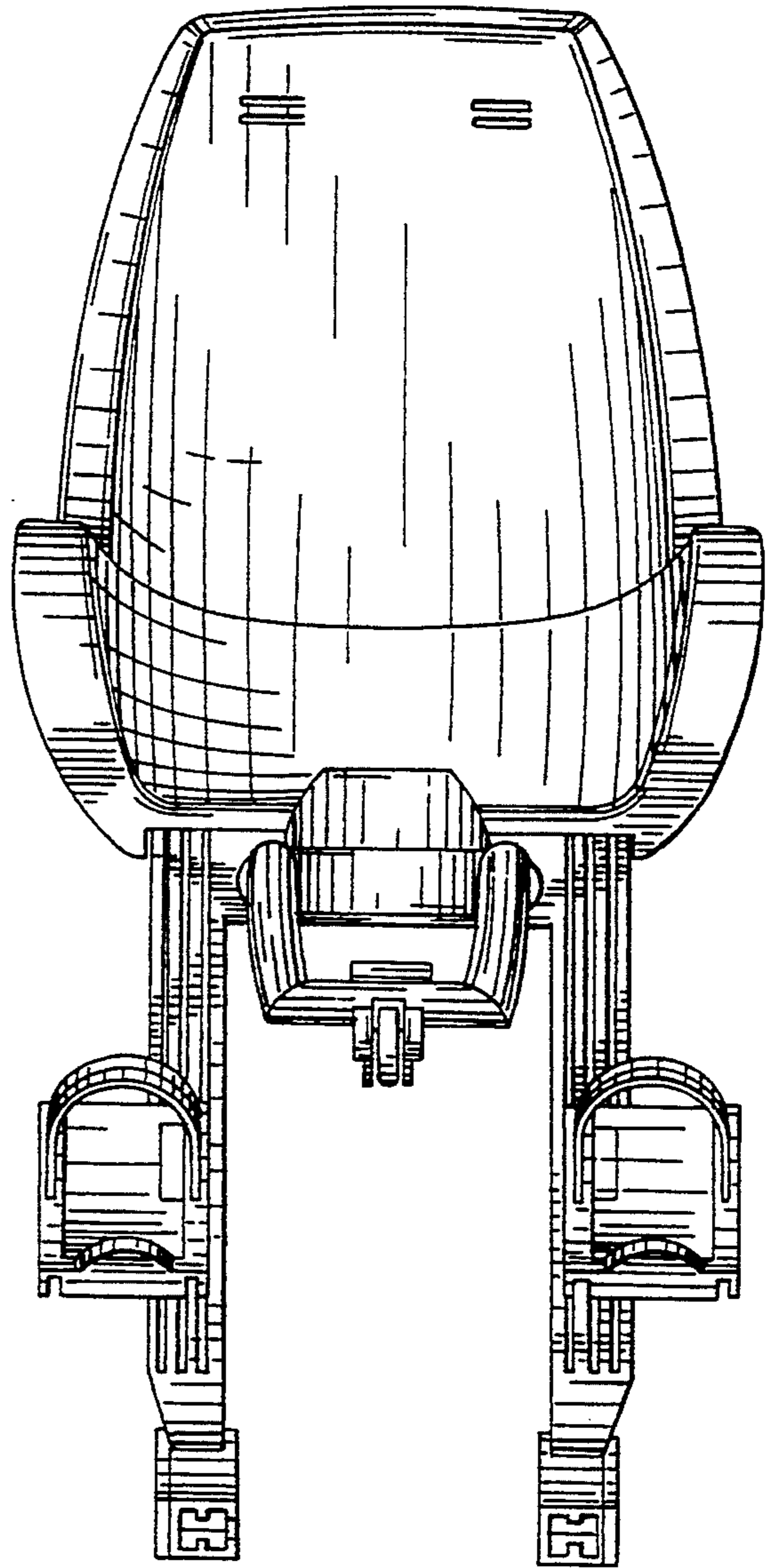

FIG. 4

FIG. 5

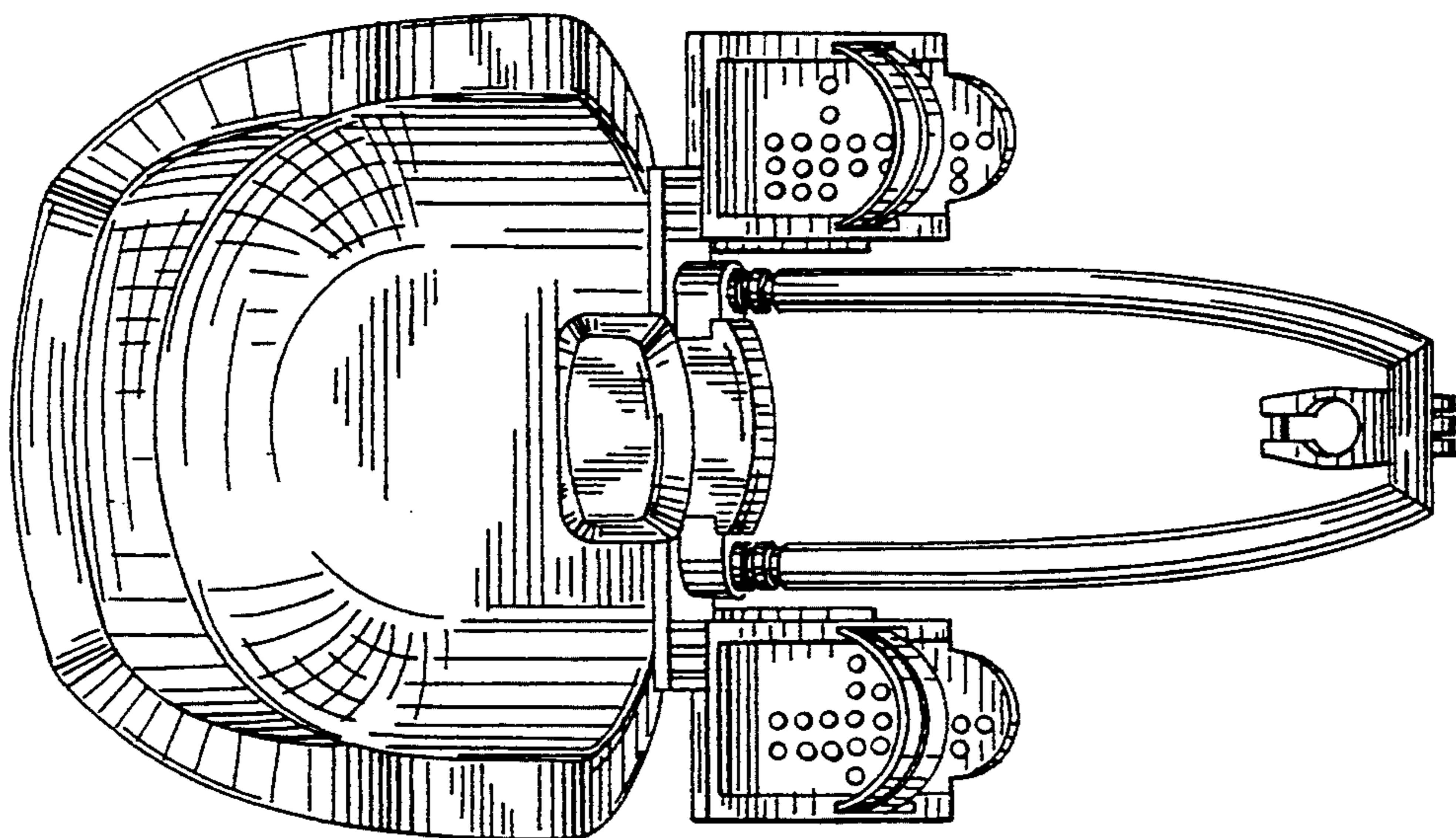
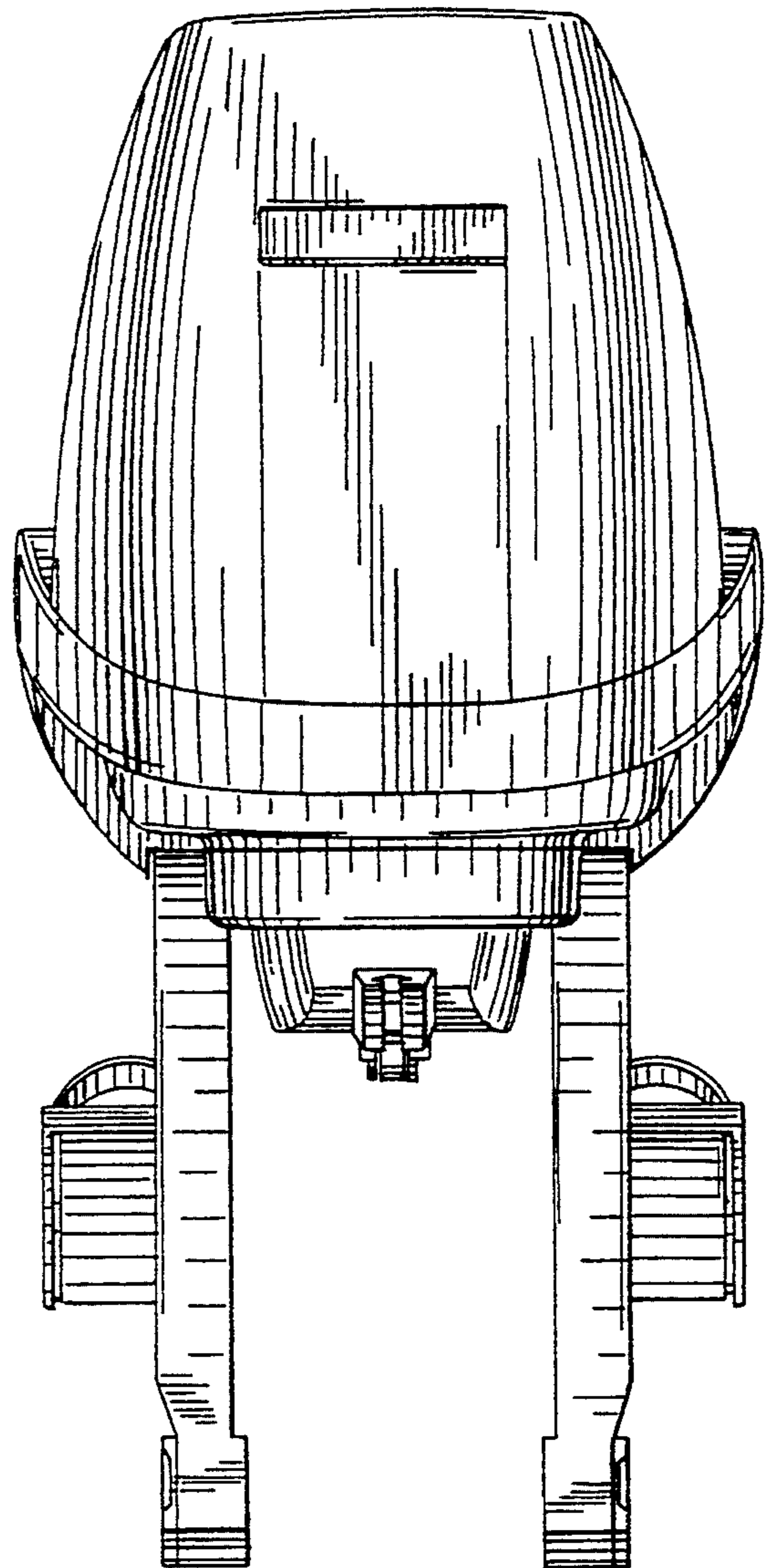

FIG. 6

FIG. 7

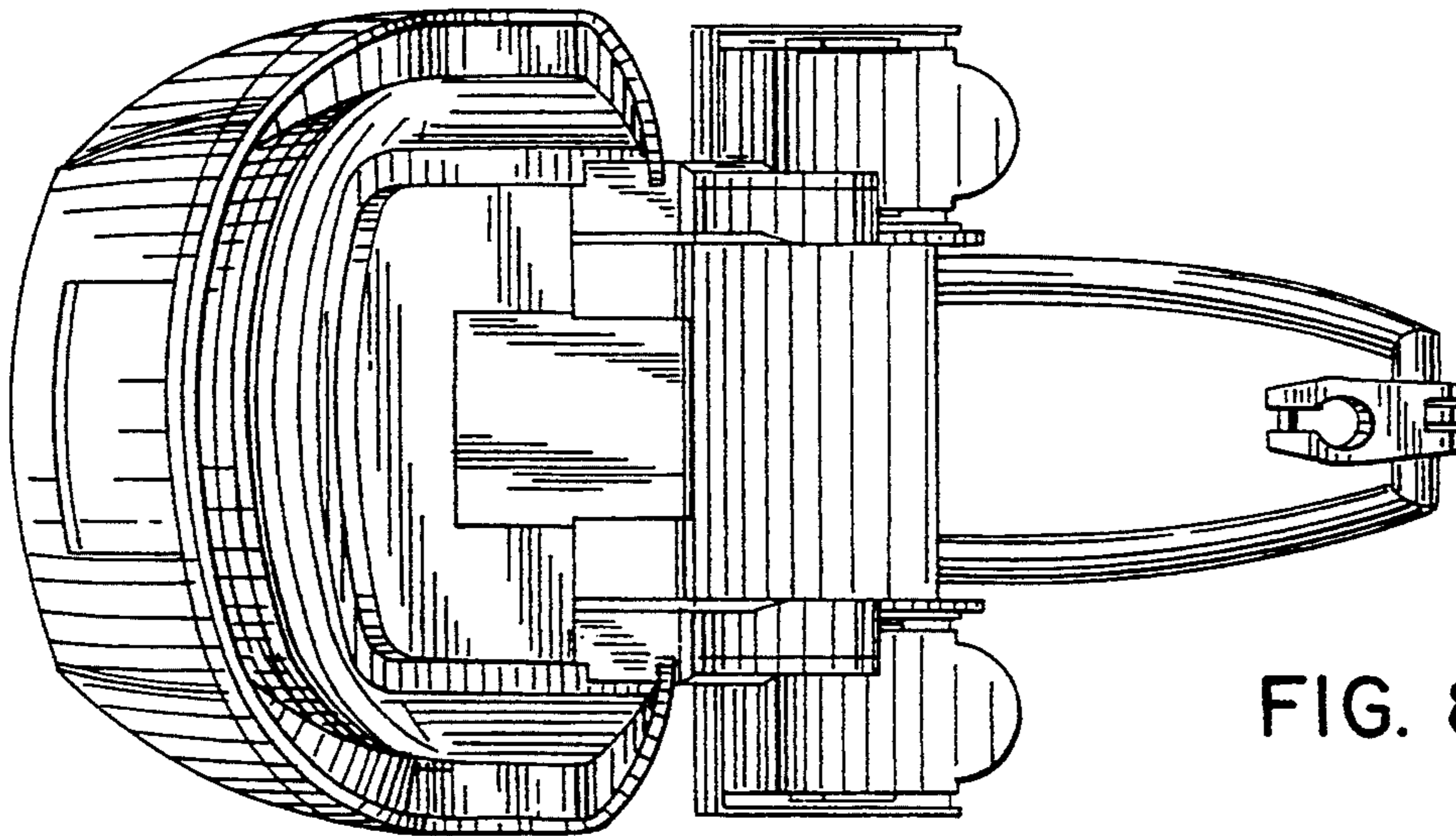
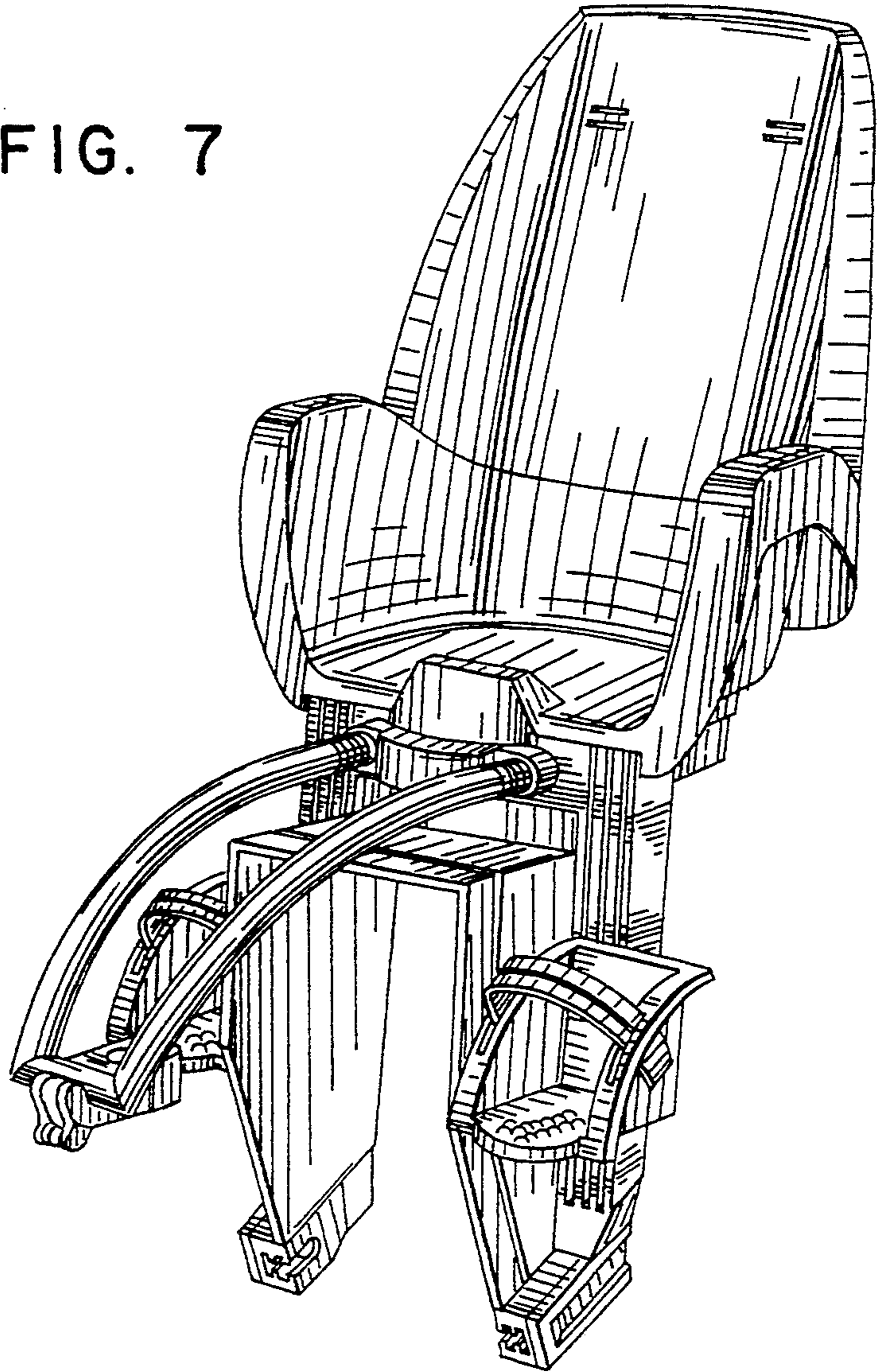

FIG. 8

FIG. 9

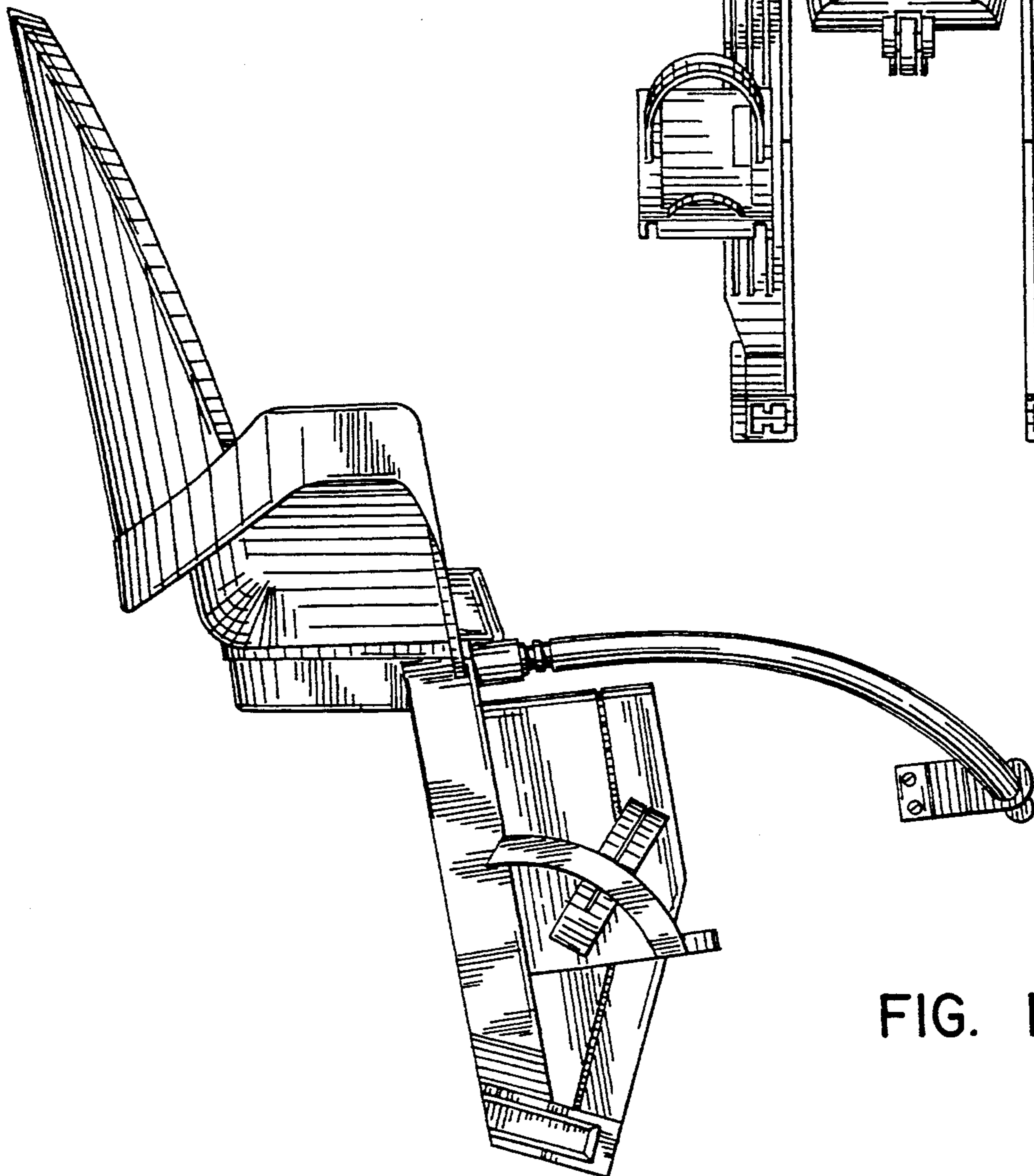
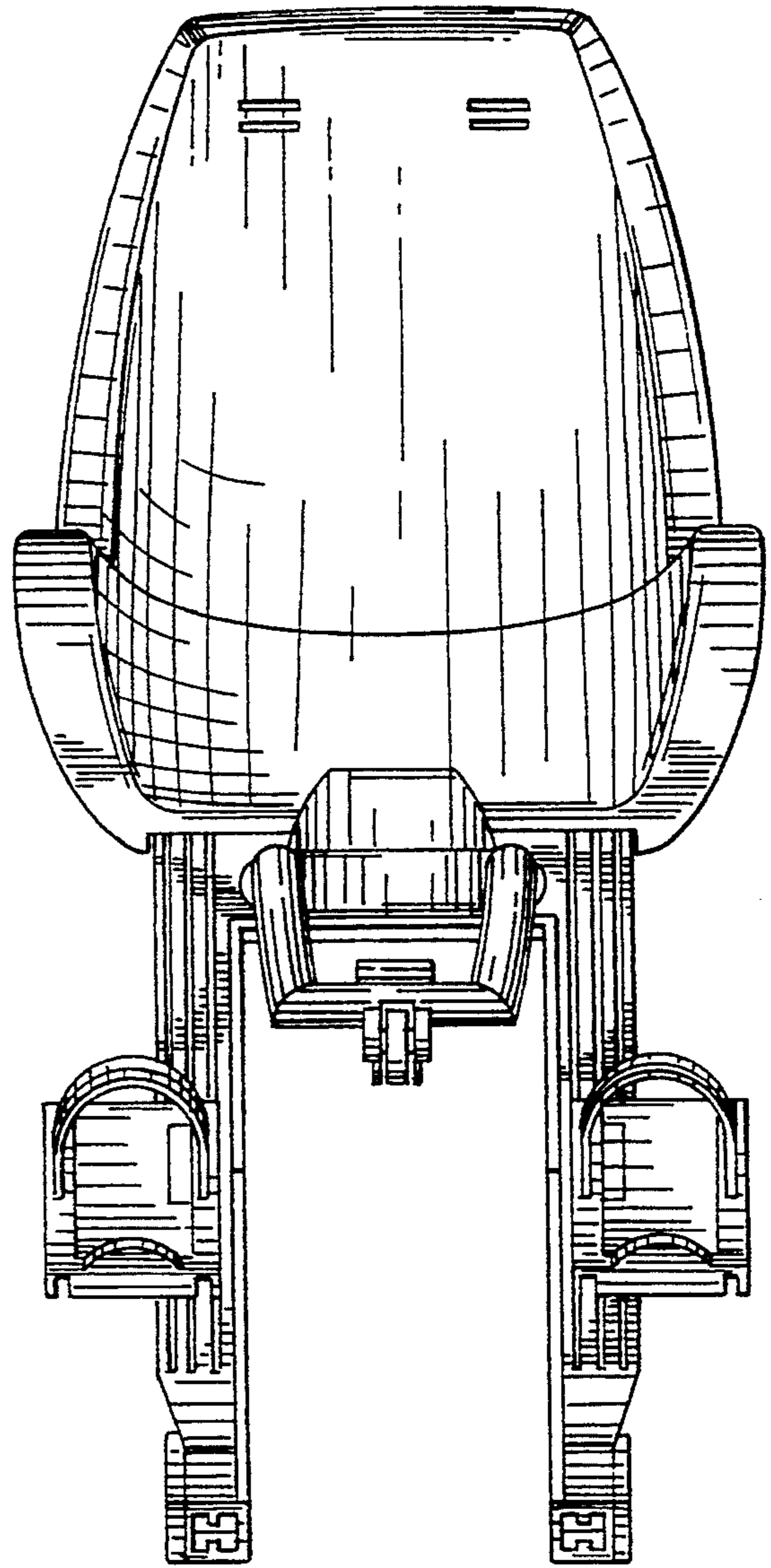

FIG. 10

FIG. 11

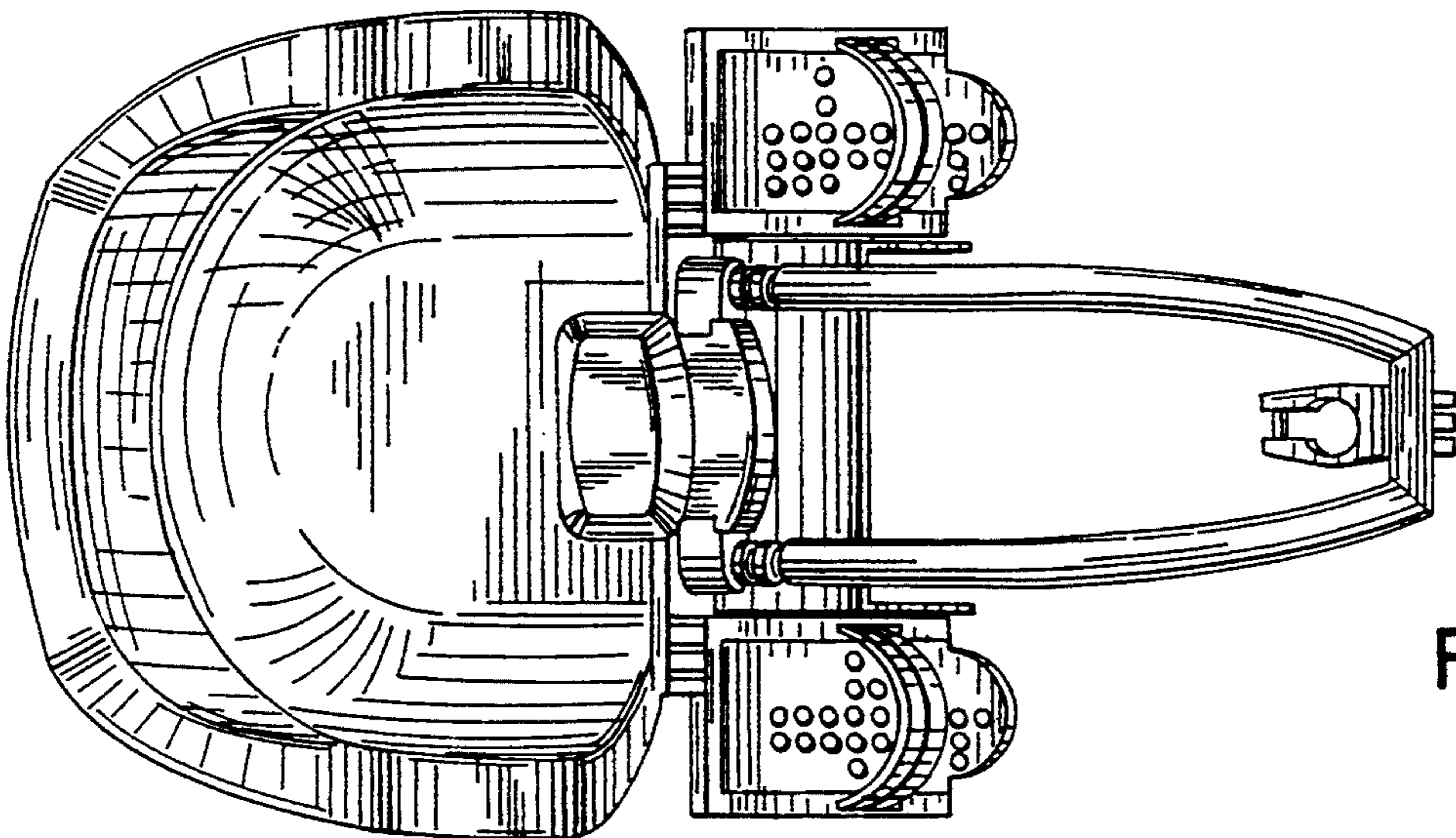
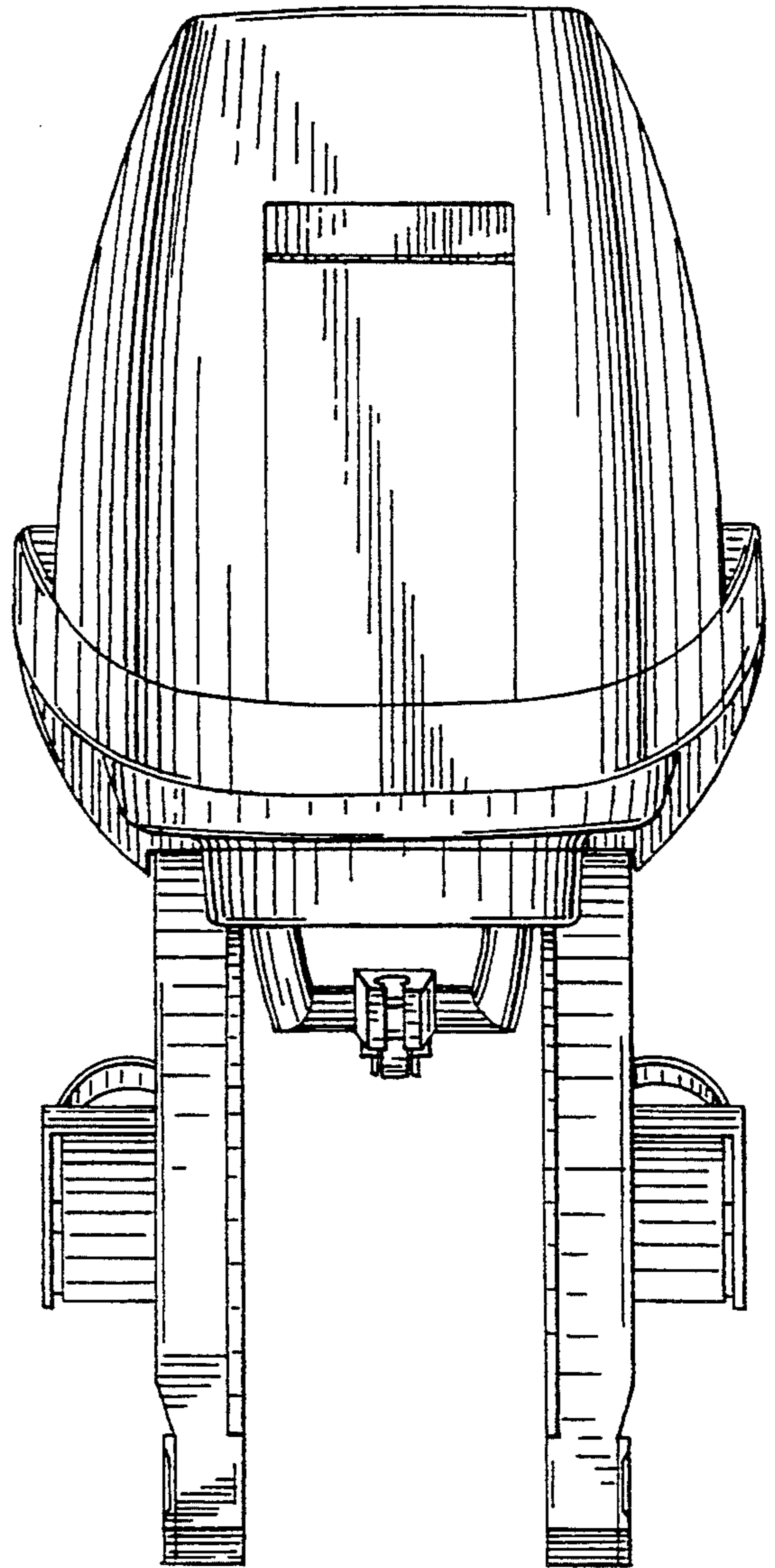

FIG. 12