



US00D356402S

United States Patent [19]
Garneau

[11] **Patent Number: Des. 356,402**
[45] **Date of Patent: ** Mar. 14, 1995**

[54] **CYCLIST'S HELMET**
[75] **Inventor: Louis Garneau,**
St-Augustin-De-Demaures, Canada

[73] **Assignee: Vetements Louis Garneau Inc.,**
Québec, Canada

[**] **Term: 14 Years**

[21] **Appl. No.: 869,368**

[22] **Filed: Apr. 15, 1992**

[30] **Foreign Application Priority Data**
Feb. 21, 1992 [CA] Canada 21-02-92-3
[52] **U.S. Cl. D29/102**
[58] **Field of Search D29/12-18;**
2/410-412, 414-418, 422-425

[56] **References Cited**
U.S. PATENT DOCUMENTS

D. 299,978 2/1989 Chiarella D29/12
D. 303,851 10/1989 Gentes D29/12

D. 309,961 8/1990 Bobrick D29/12
D. 319,112 8/1991 Broersma D29/12
D. 339,427 9/1993 Gentes D29/12

OTHER PUBLICATIONS

Bicycling, Jul. 1988, p. 119. "Giant AT750 Helmet".
American Bicyclist & Motorcyclist, Mar. 1985, p. 51
"Bell Helmet".

Primary Examiner—Ruth McInroy
Attorney, Agent, or Firm—Collard & Roe

[57] **CLAIM**

The ornamental design for a cyclist's helmet, as shown and described.

DESCRIPTION

FIG. 1 is a top, front and side perspective view of a cyclist's helmet showing my new design;
FIG. 2 is a right side elevational view thereof;
FIG. 3 is a front elevational view thereof;
FIG. 4 is a rear elevational view thereof;
FIG. 5 is a top plan view thereof; and,
FIG. 6 is a bottom plan view thereof.

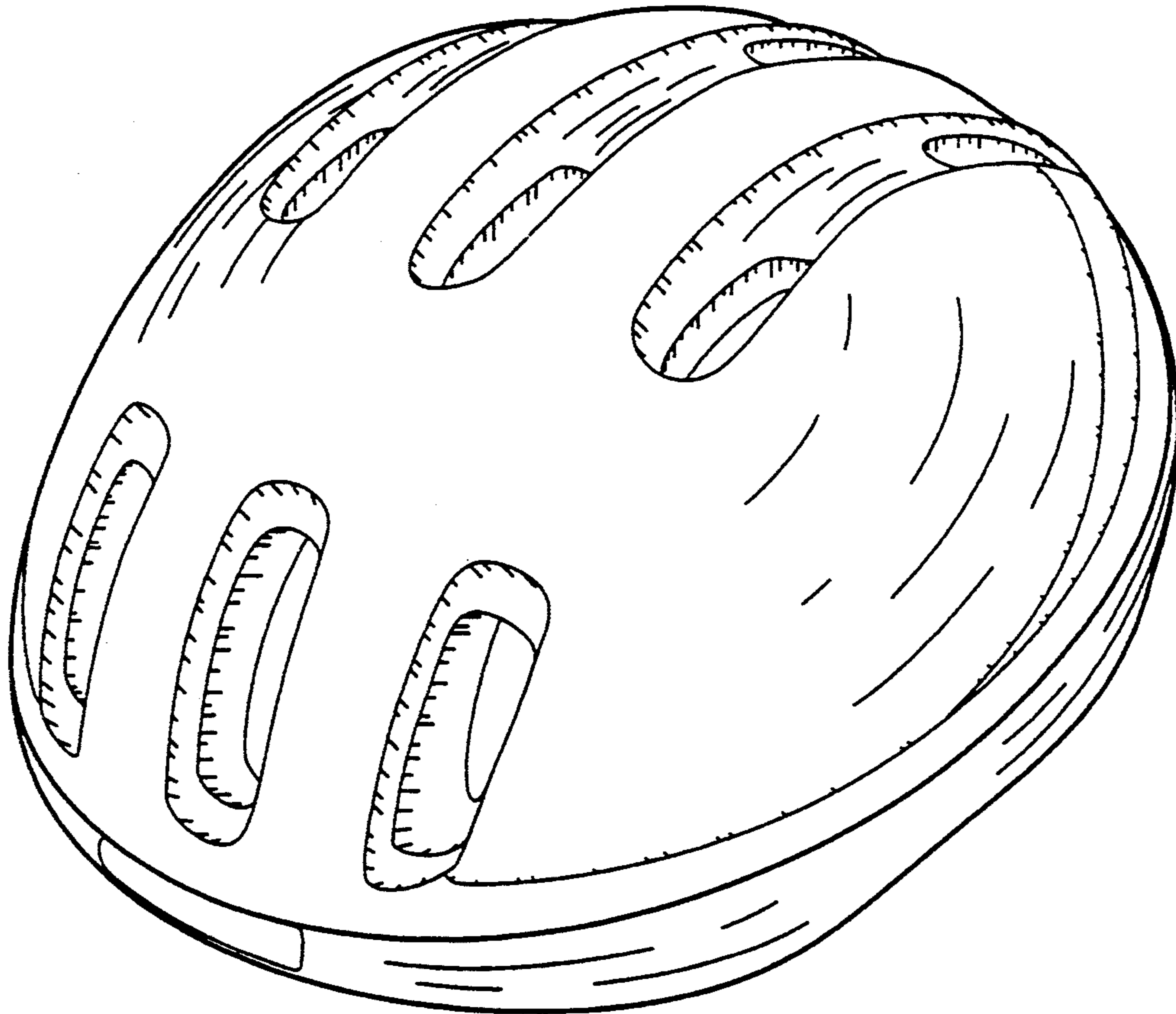

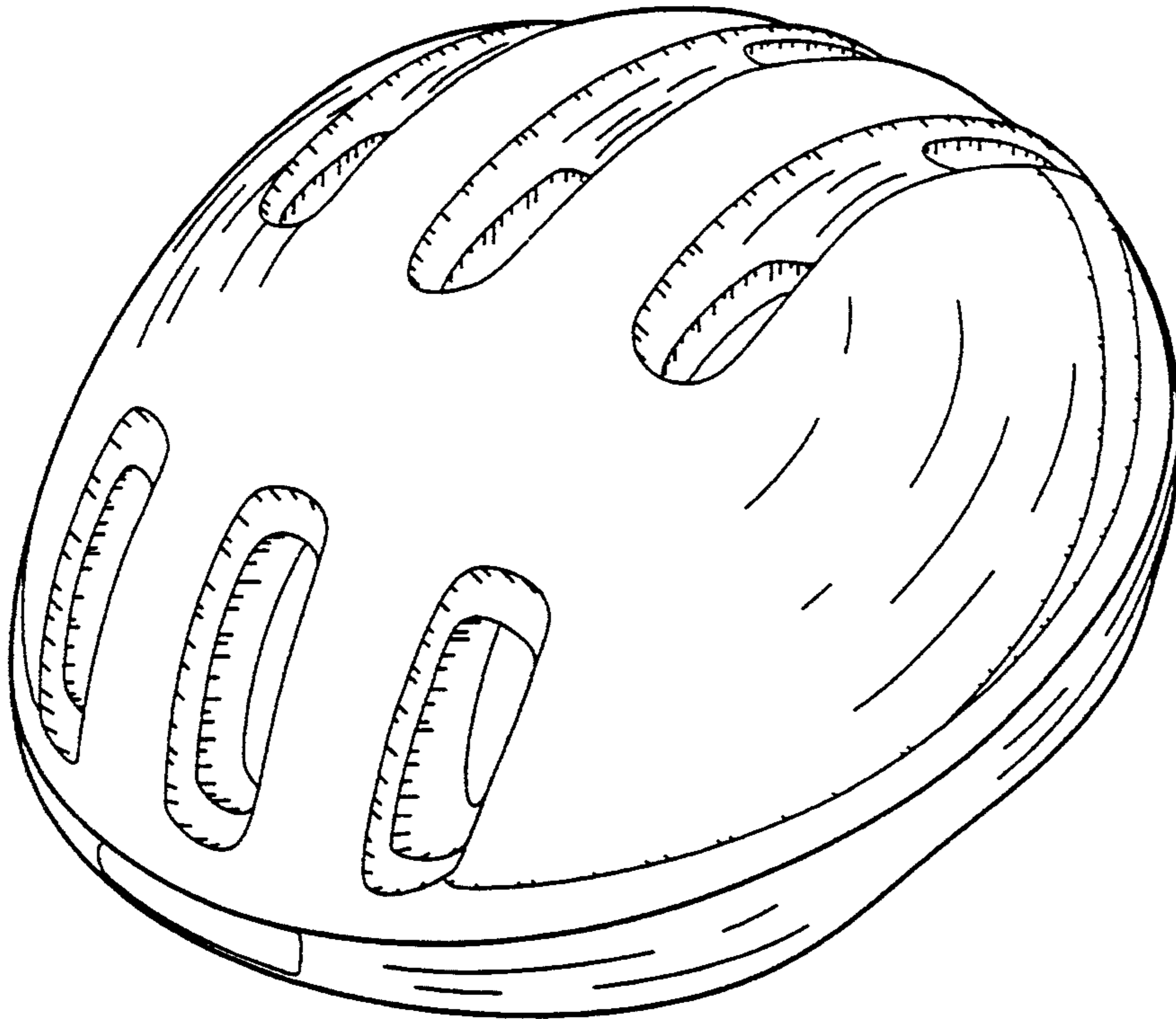

Fig.1

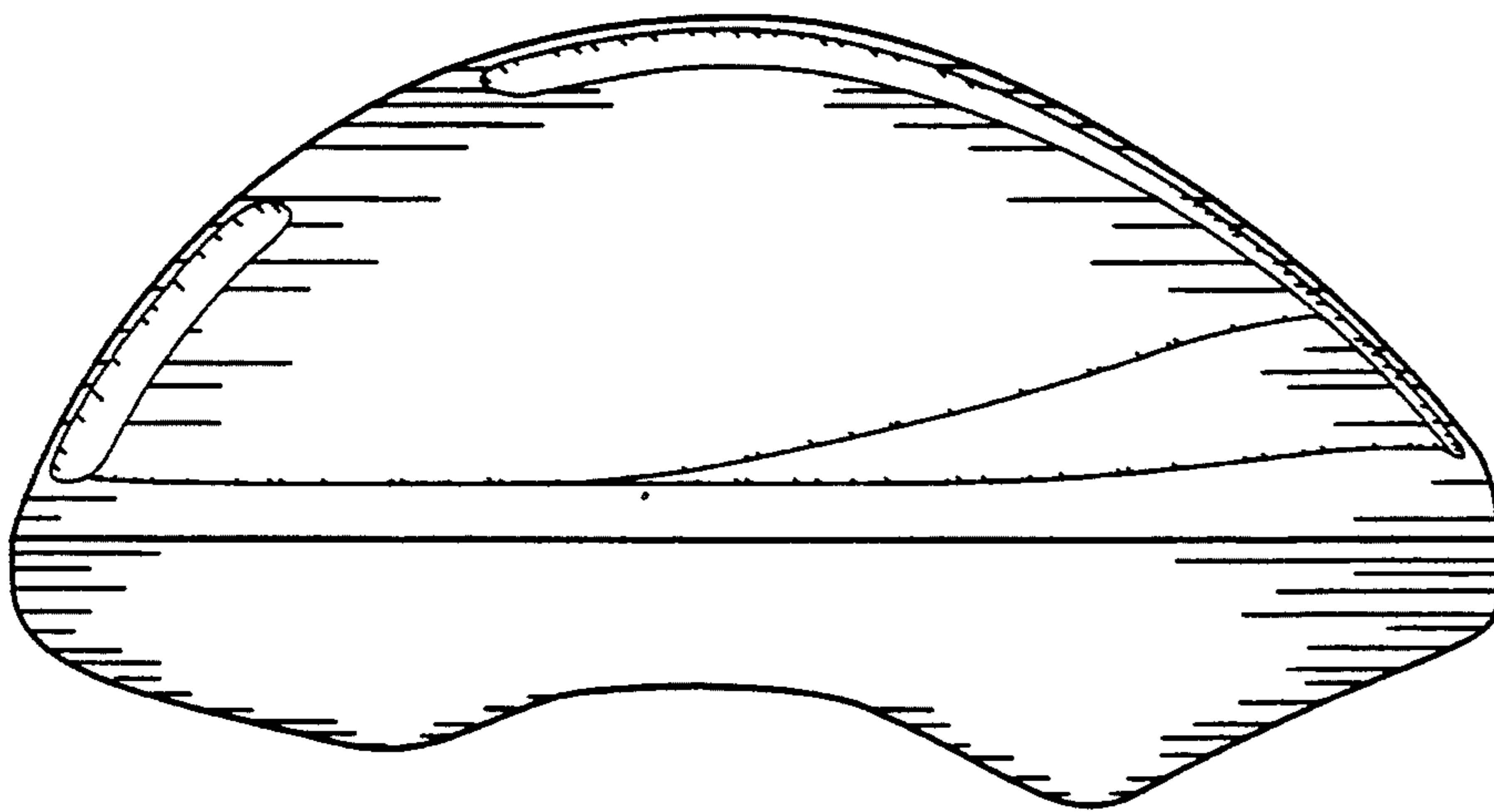

Fig.2

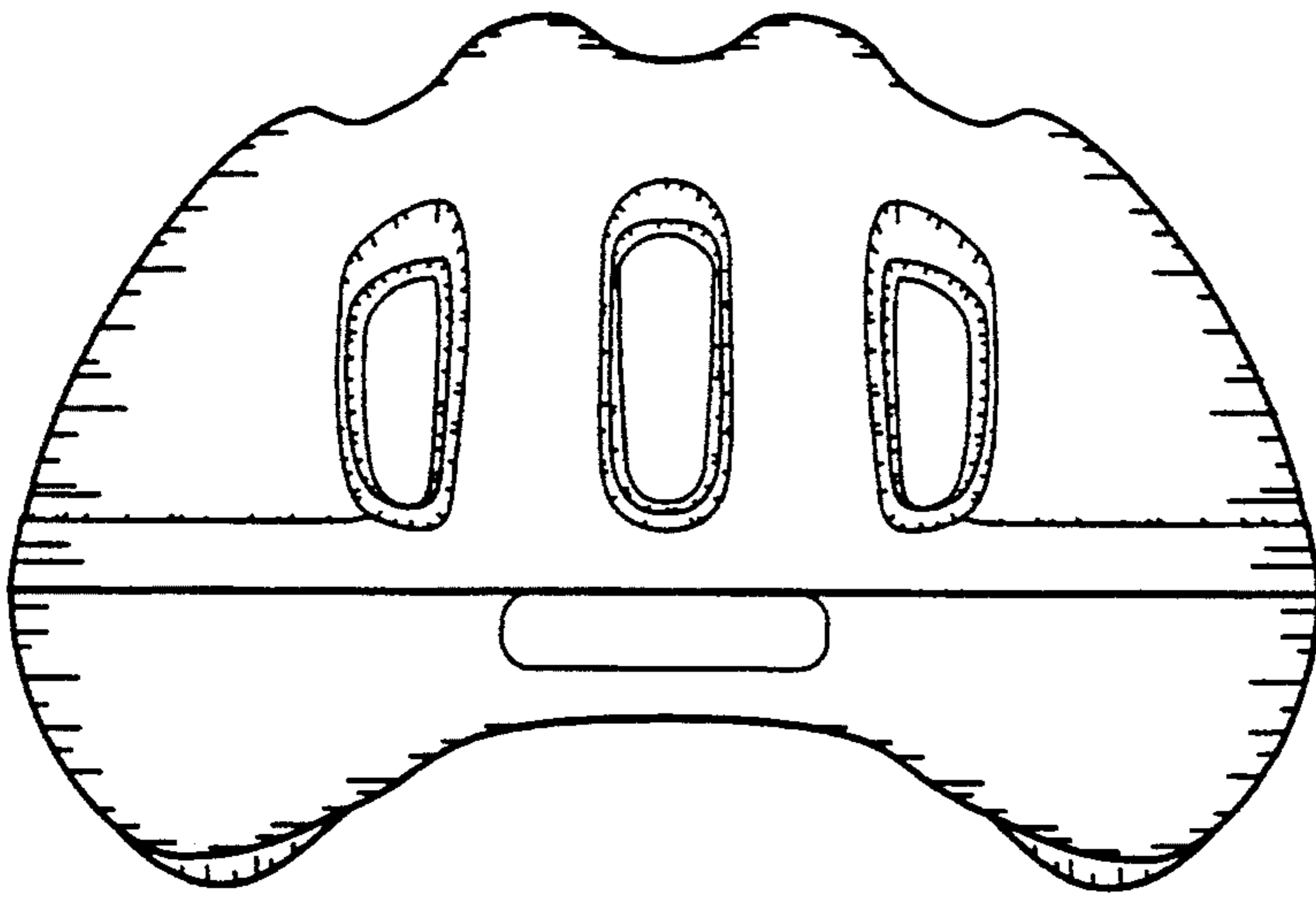

Fig.3

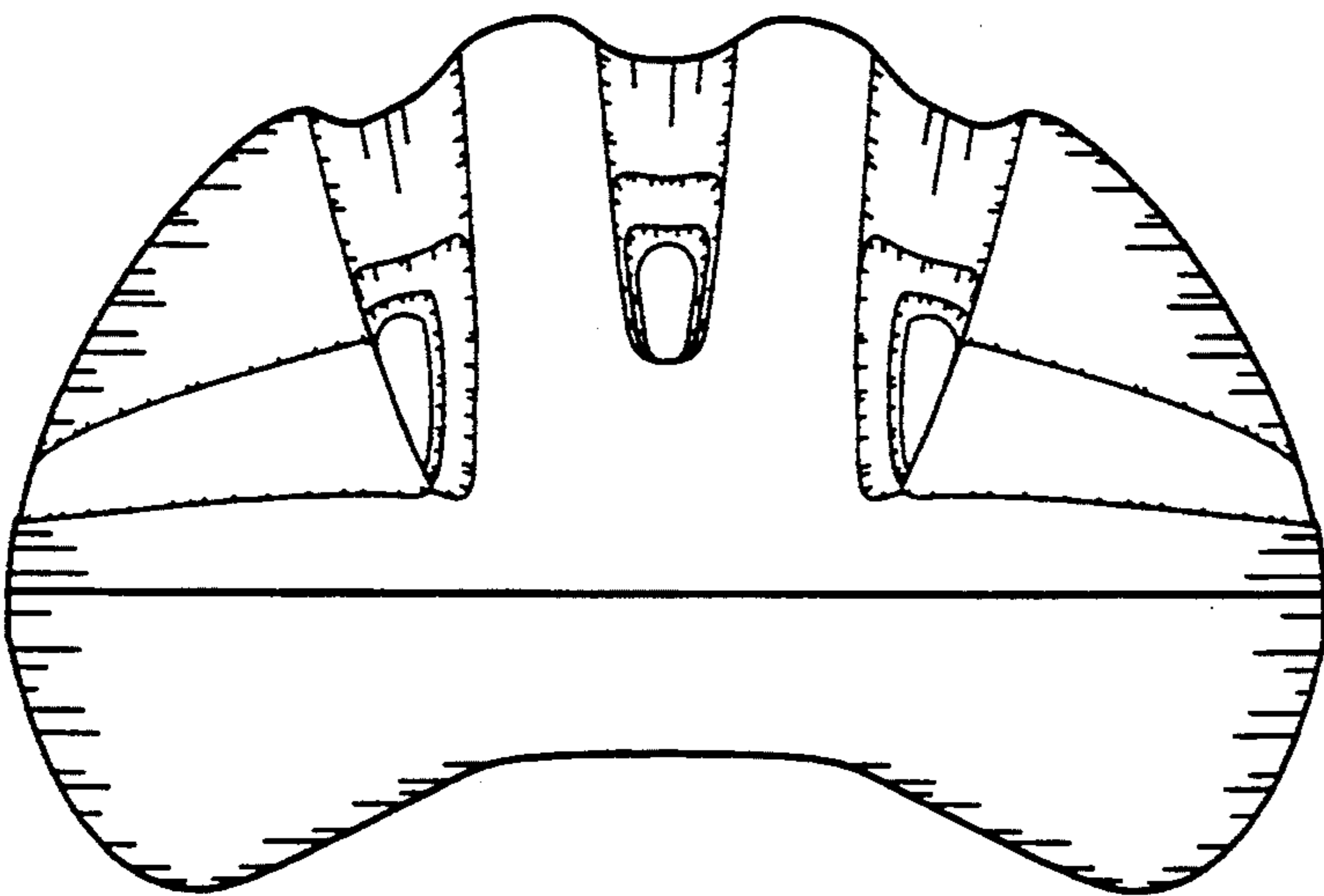

Fig.4

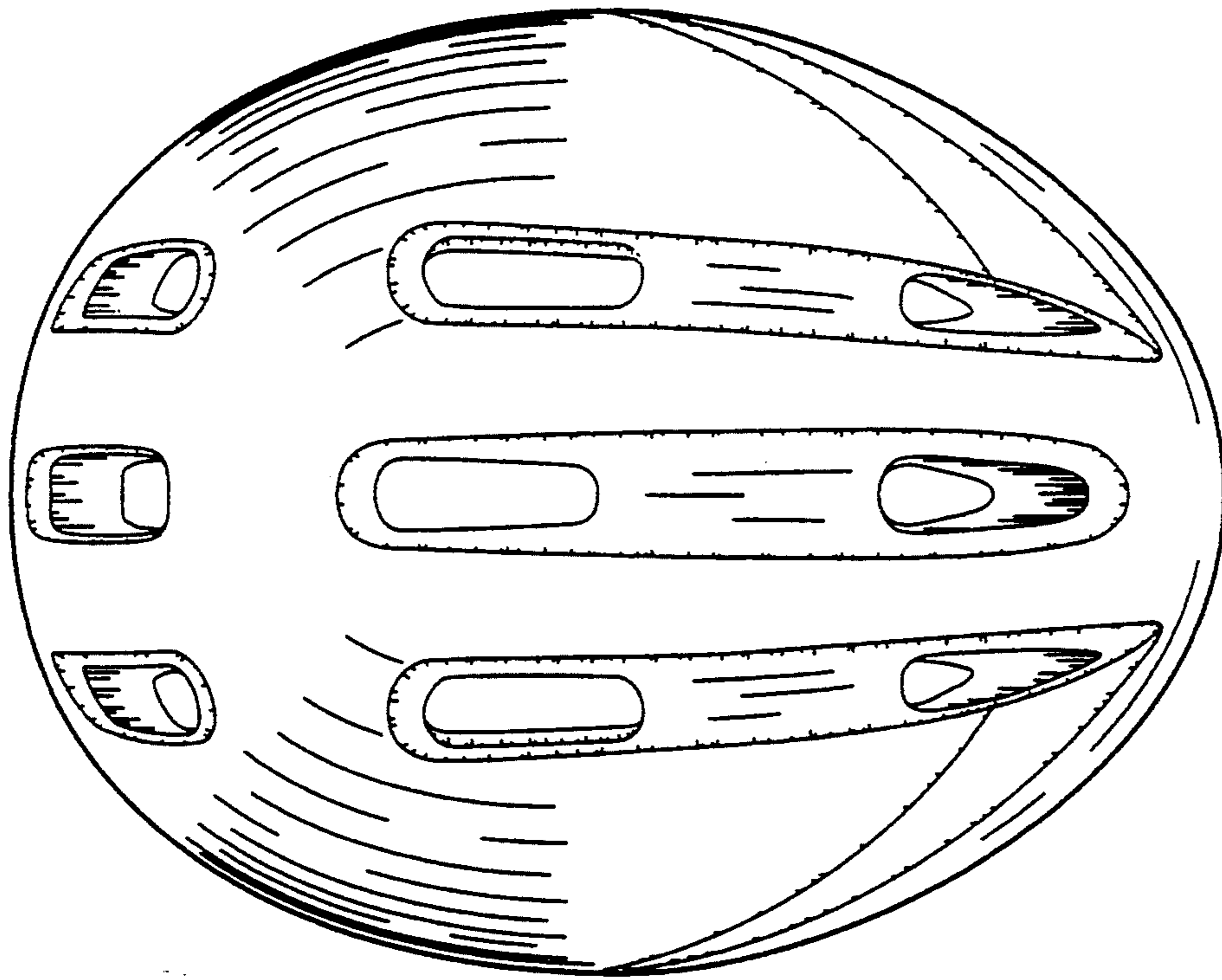

Fig.5

