



US00D356352S

United States Patent [19]

[11] Patent Number: **Des. 356,352**

Johnson

[45] Date of Patent: **** Mar. 14, 1995**

[54] SAFETY HURDLE

[76] Inventor: **Jerry W. Johnson**, 700 Central Ave.,
Louisville, Ky. 40208

[**] Term: **14 Years**

[21] Appl. No.: **9,097**

[22] Filed: **Jun. 3, 1993**

[52] U.S. Cl. **D21/199; D6/601;**
D19/34.1

[58] Field of Search D21/199, 54; 482/14,
482/15, 19; D19/34.1-34.5, 59, 108; D16/128;
D8/354, 323-329; 211/42, 43, 183; 281/45;
D25/112-113, 138; D6/314, 300, 320, 601

[56] **References Cited**

U.S. PATENT DOCUMENTS

D. 315,648	3/1991	Castillo	D21/54 X
1,607,650	11/1926	Smith .	
3,513,491	5/1970	Gordon .	
3,628,790	12/1971	Gordon .	
3,965,507	6/1976	Reiland .	
4,758,195	7/1988	Walsh	D21/108 X
4,892,302	1/1990	Daigle .	

OTHER PUBLICATIONS

Carr Lane Manufacturing Co., p. 31, (Angle Bracket).

Terra System One: Custom Components.
"Gill Sports" Catalogue Publication.

Primary Examiner—Melvin B. Feifer
Assistant Examiner—Cheri Cohen
Attorney, Agent, or Firm—Middleton & Reutlinger

[57] **CLAIM**

The ornamental design for a safety hurdle, as shown and described.

DESCRIPTION

FIG. 1 is a perspective view of a safety hurdle showing my new design;
FIG. 2 is a top plan view of FIG. 1;
FIG. 3 is a bottom plan view of FIG. 1;
FIG. 4 is a side elevational view of FIG. 1;
FIG. 5 is an opposite side elevational view of FIG. 1;
FIG. 6 is a front elevation view of FIG. 1;
FIG. 7 is a rear elevational view of FIG. 1;
FIG. 8 is a perspective view of a second alternate embodiment;
FIG. 9 is a top plan view of FIG. 8;
FIG. 10 is a bottom plan view of FIG. 8;
FIG. 11 is a side elevational view of FIG. 8;
FIG. 12 is an opposite side elevational view of FIG. 8;
FIG. 13 is a front elevation view of FIG. 8; and,
FIG. 14 is rear elevational view of FIG. 8.

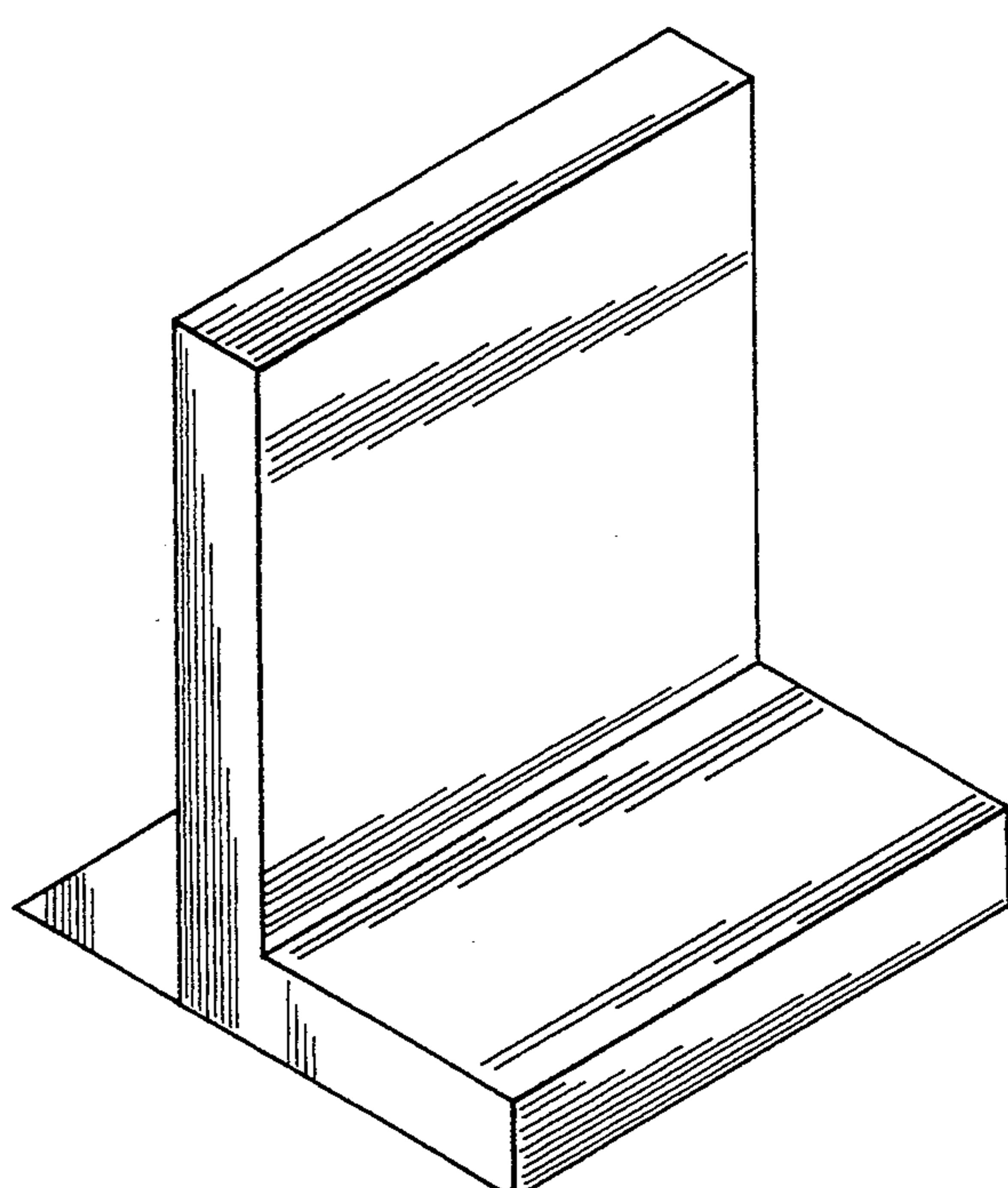
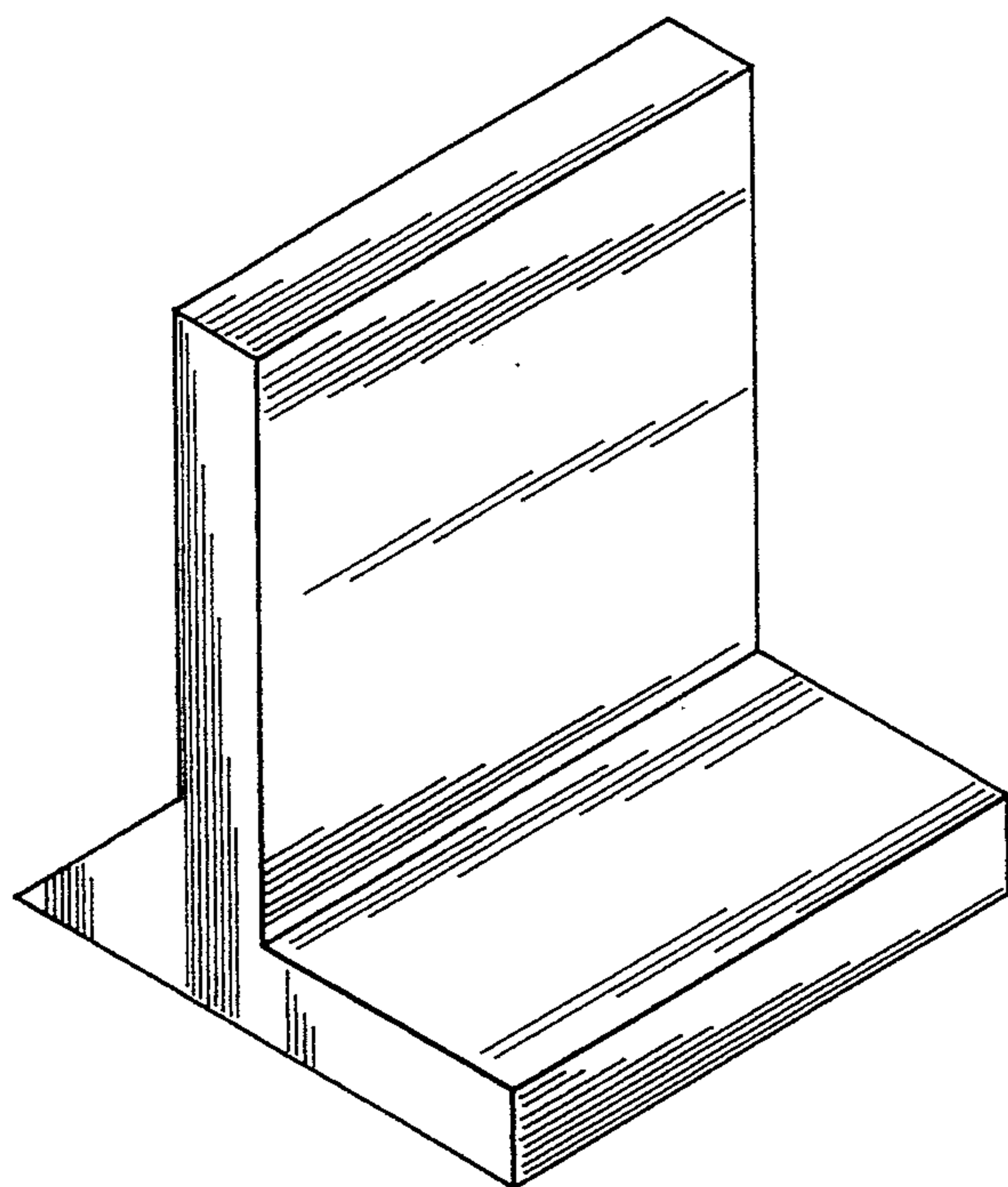

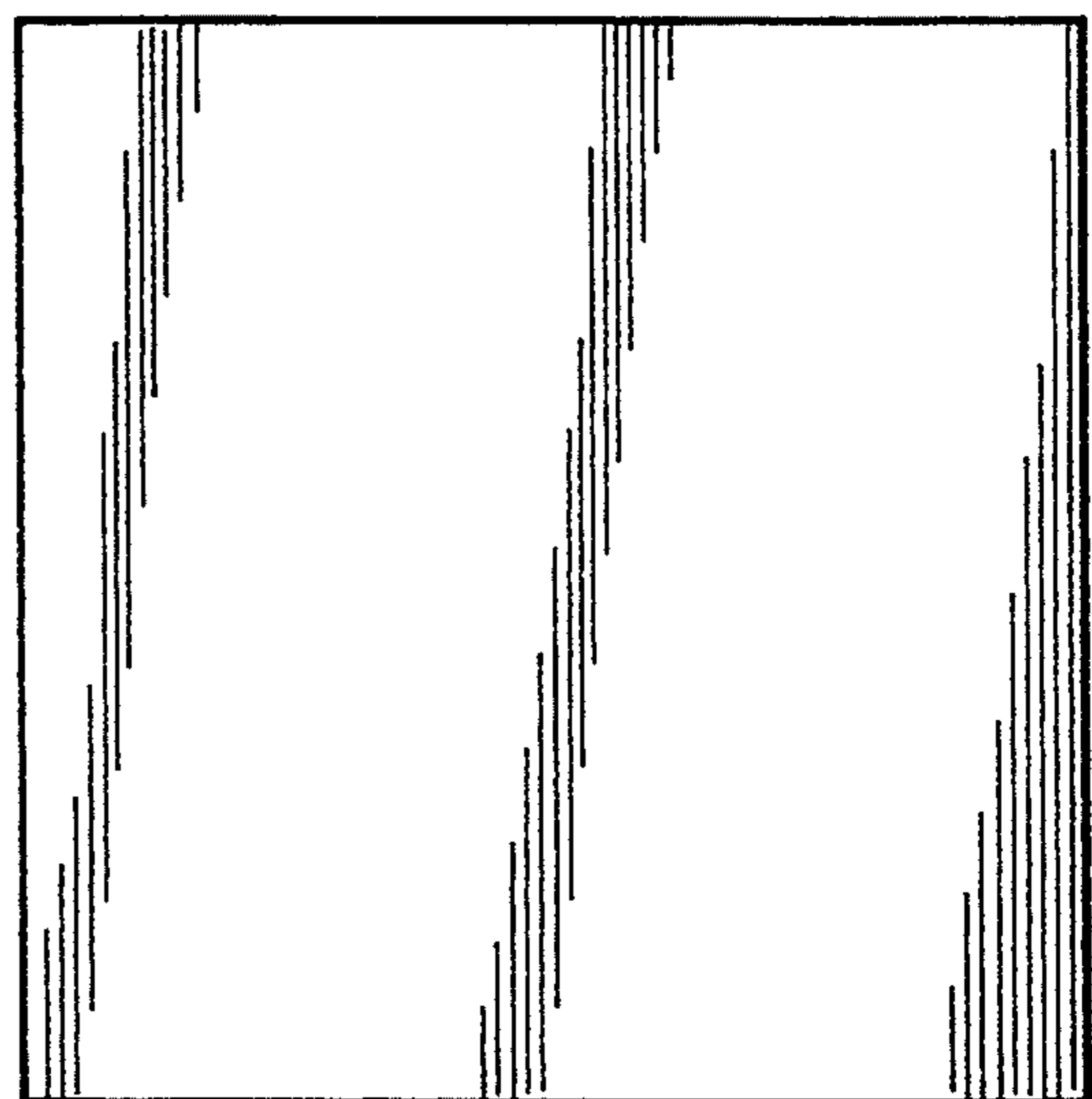
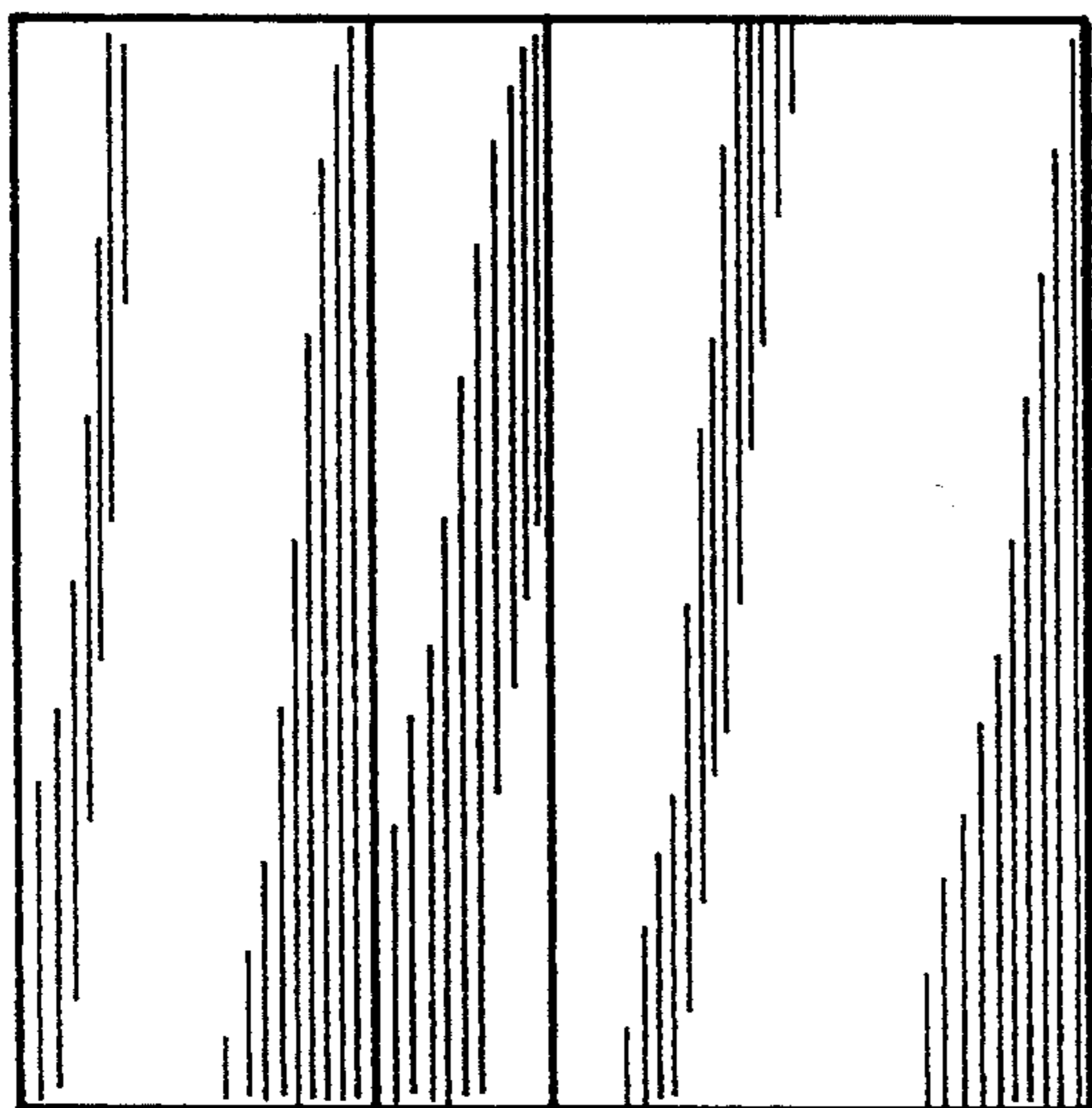
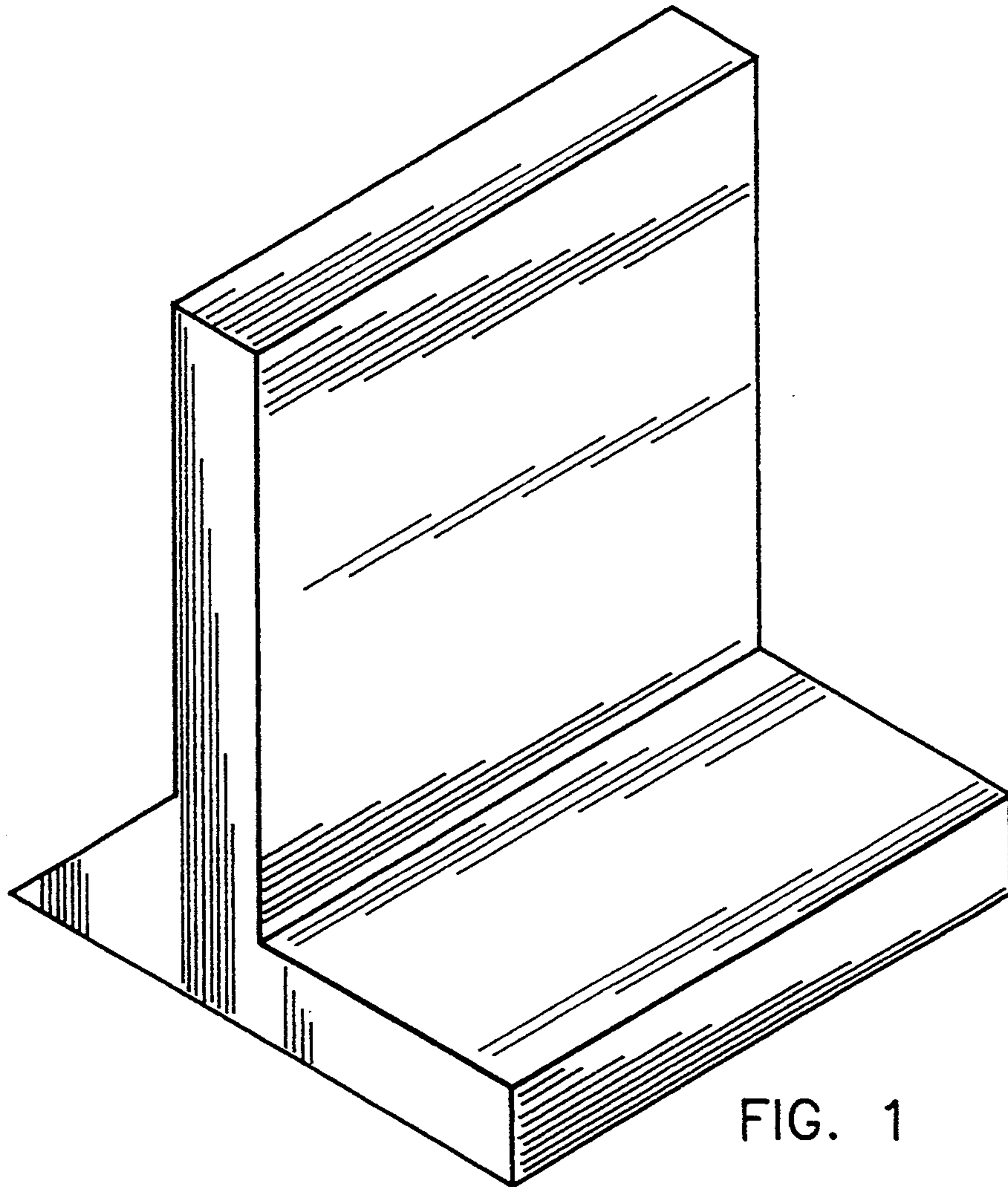

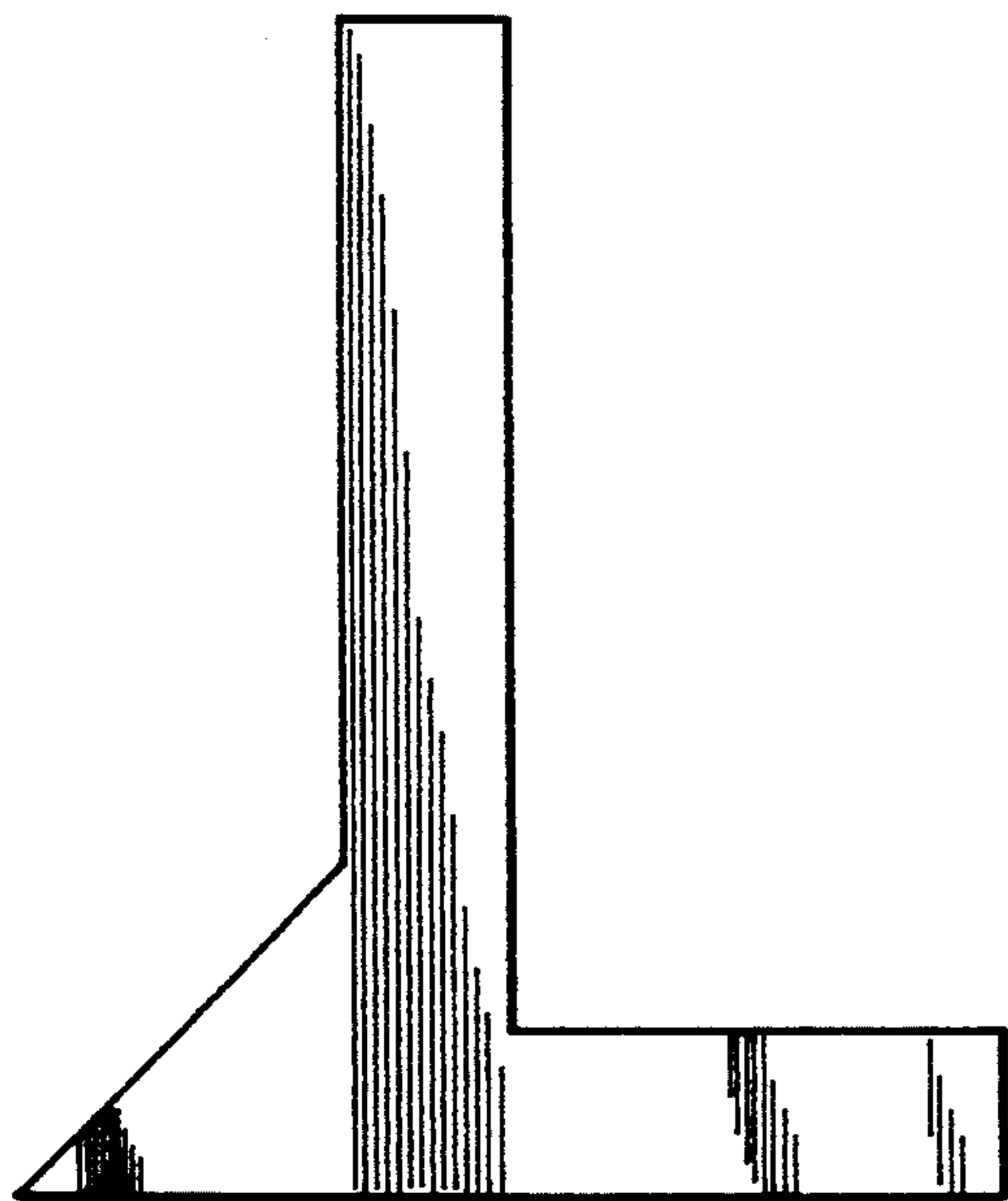

FIG. 4

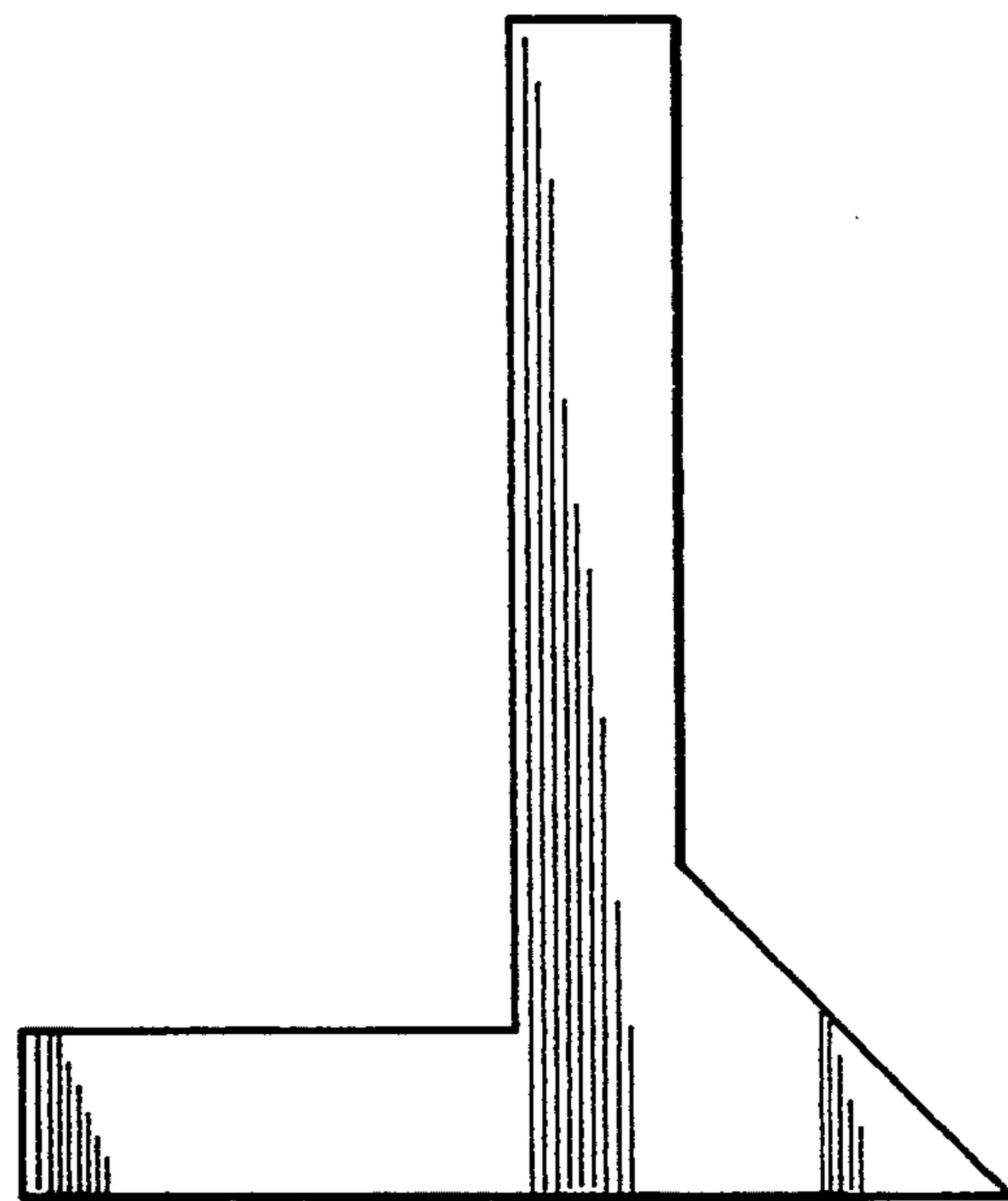

FIG. 5

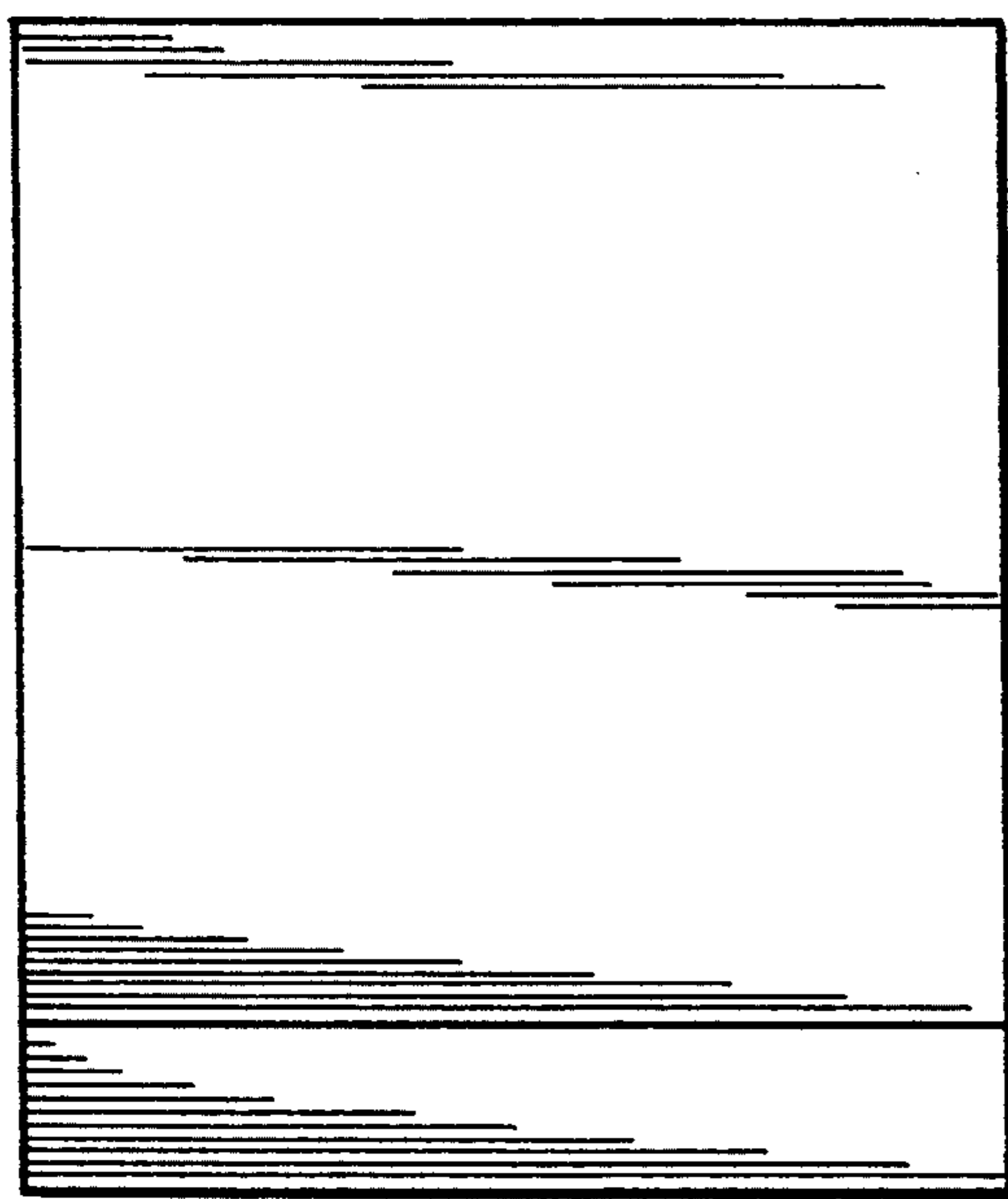

FIG. 6

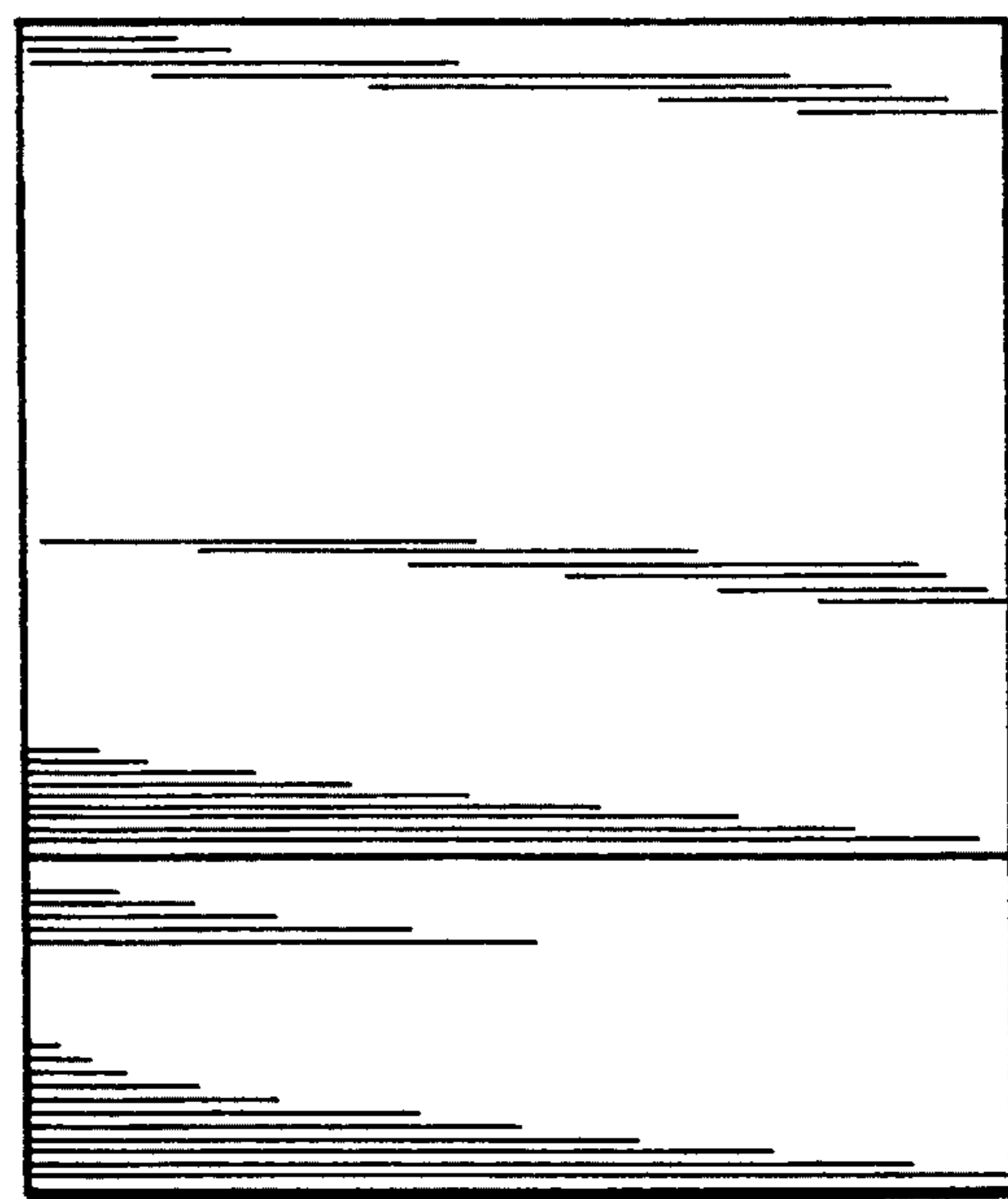

FIG. 7

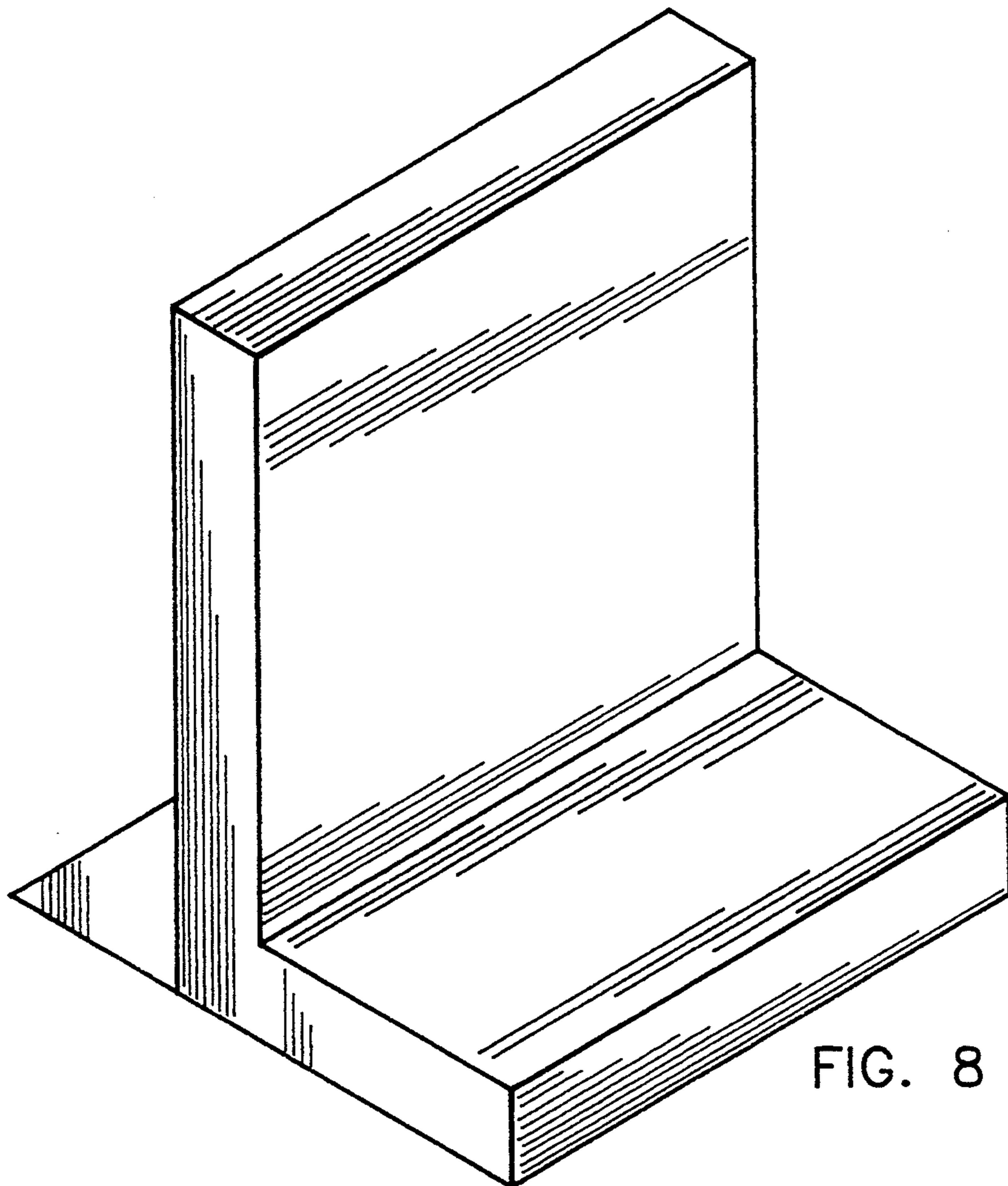

FIG. 8

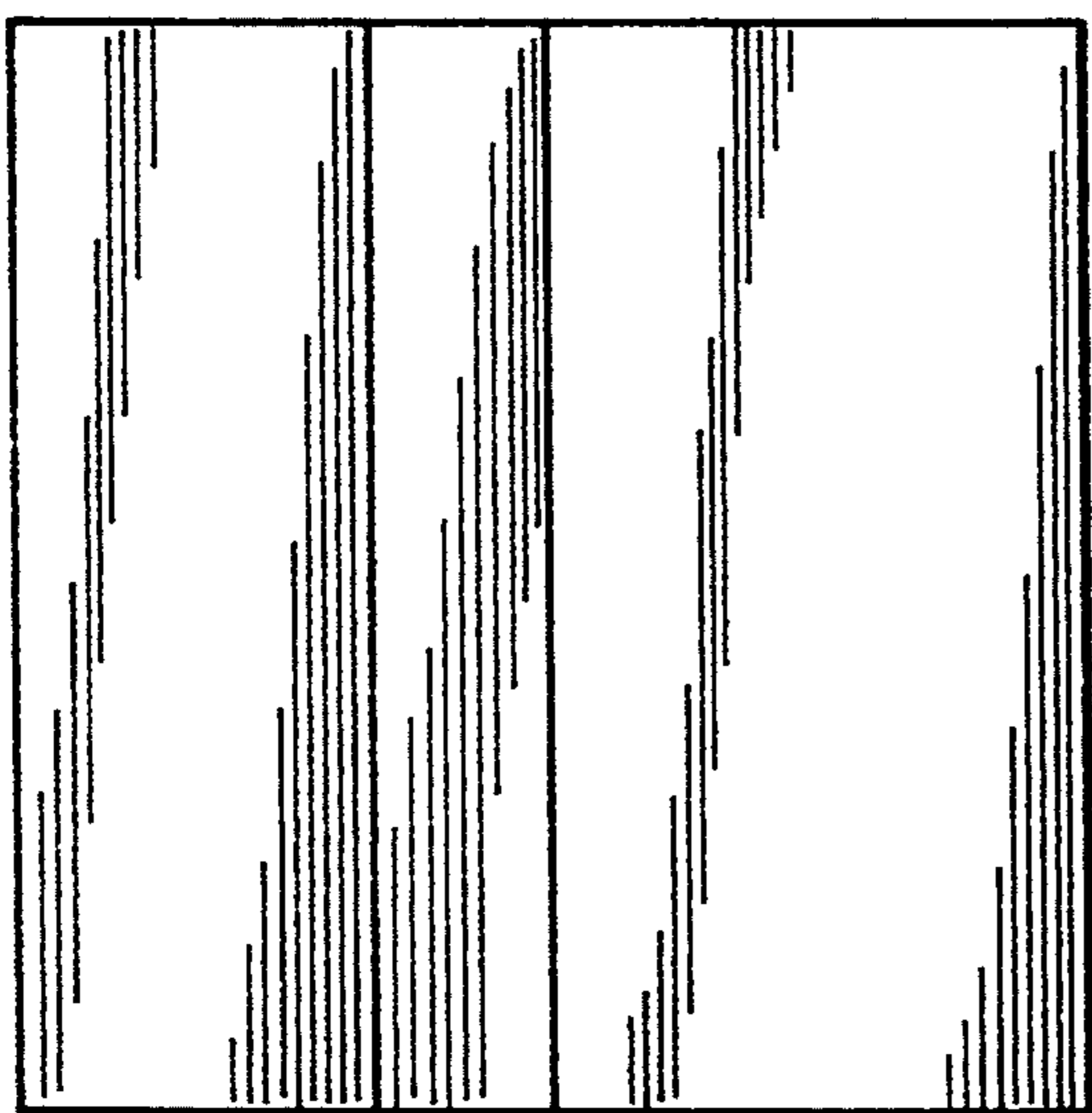

FIG. 9

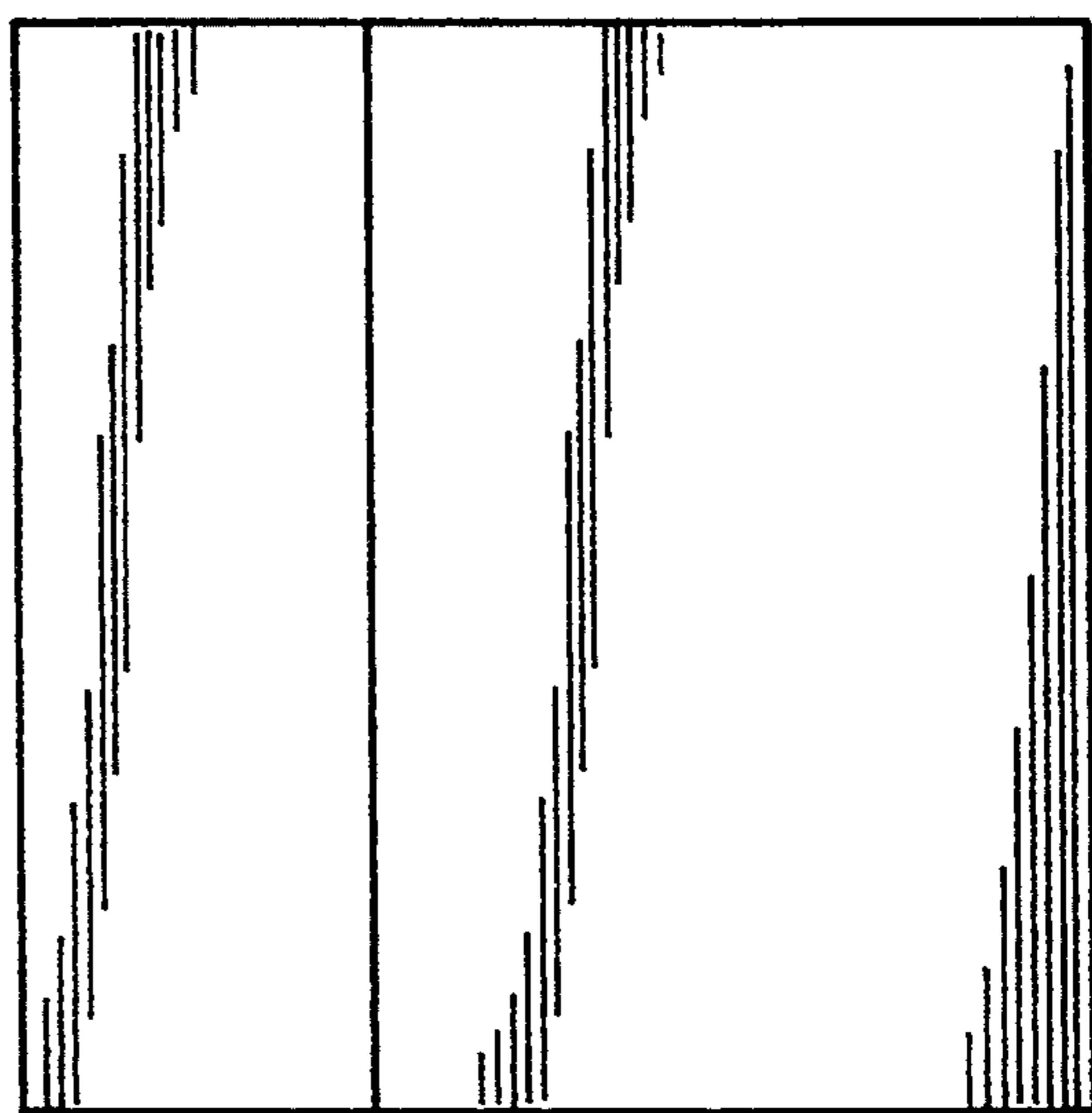

FIG. 10

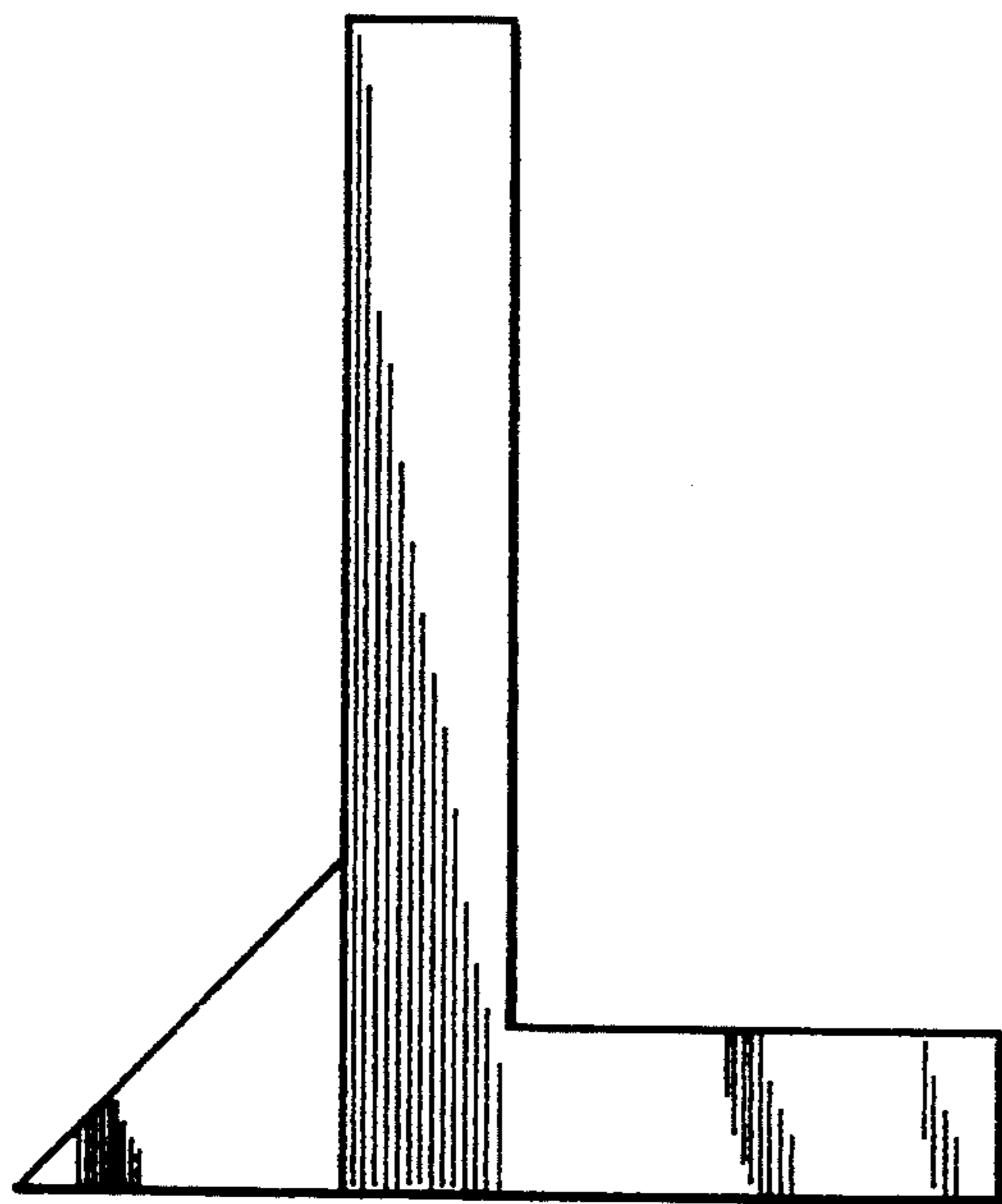

FIG. 11

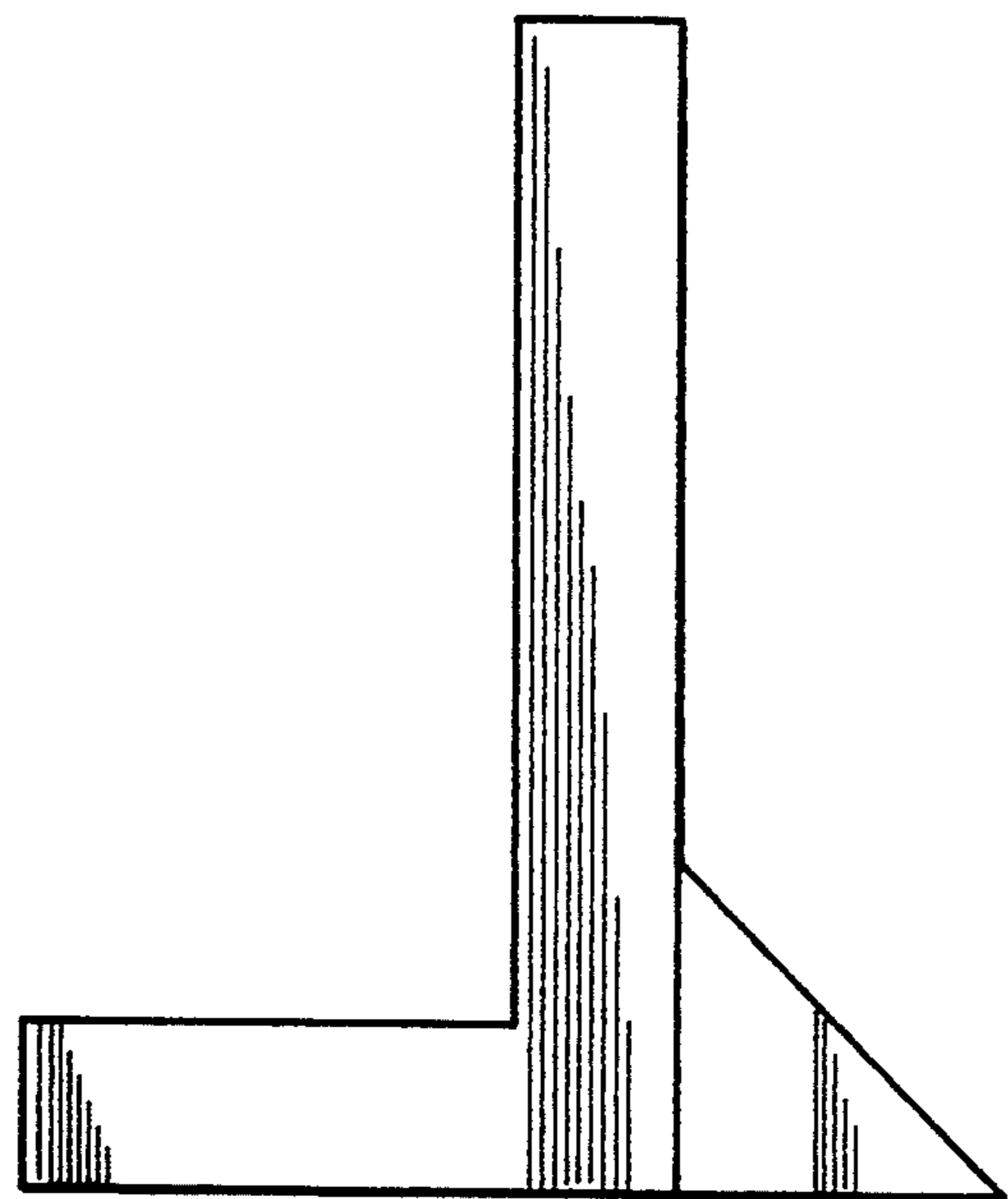

FIG. 12

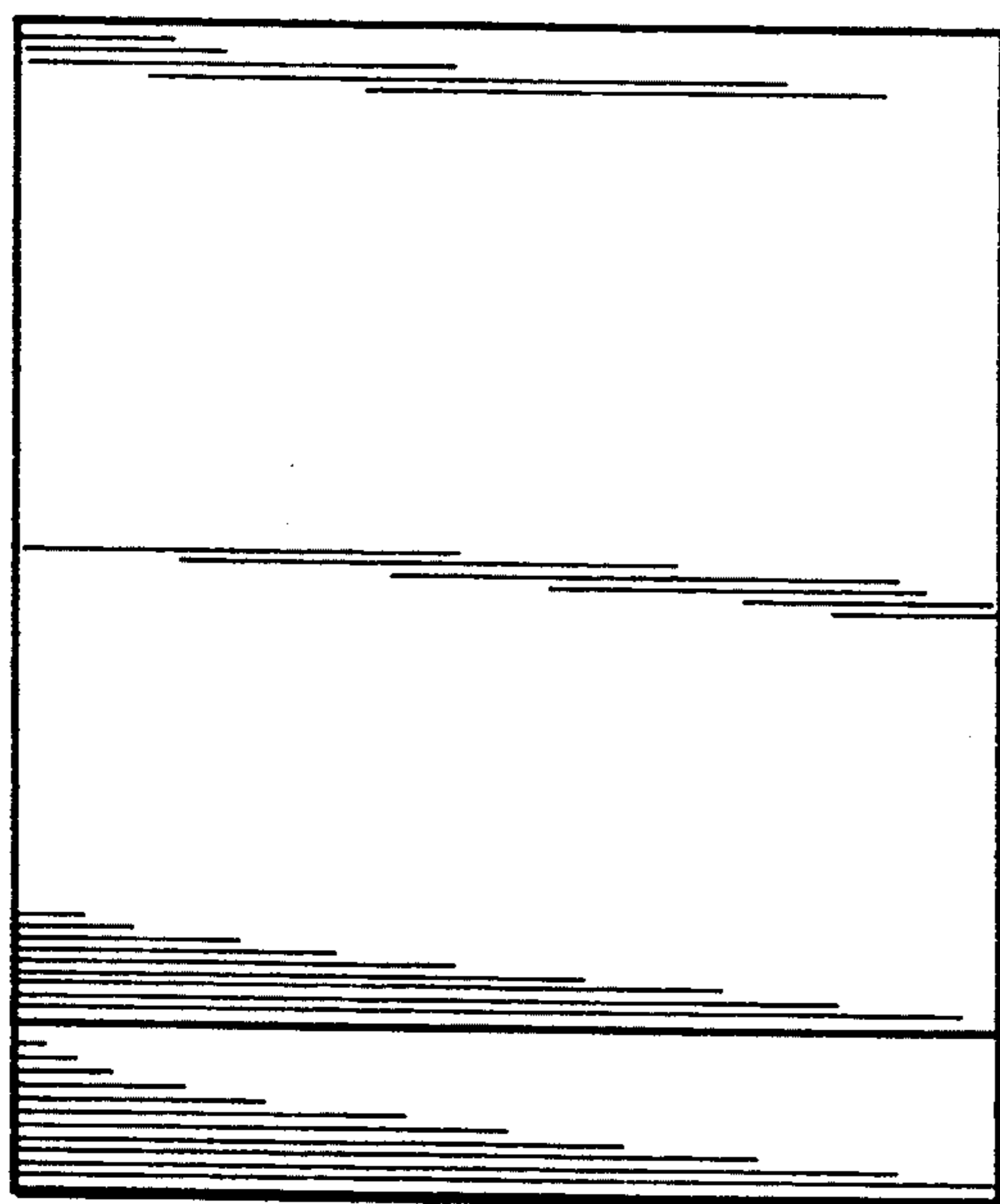

FIG. 13

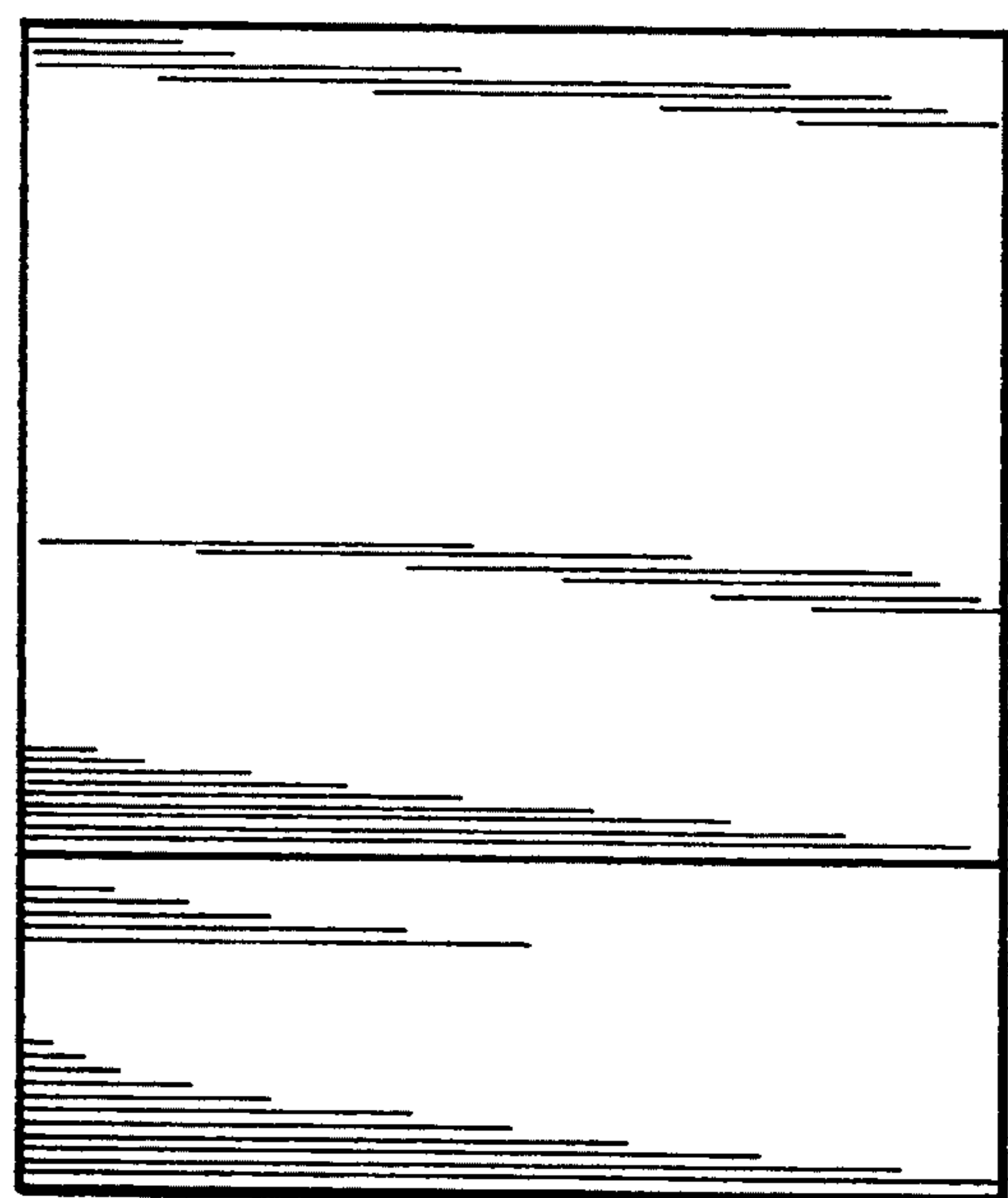

FIG. 14