



US00D356351S

United States Patent [19]

[11] Patent Number: **Des. 356,351**

Watts

[45] Date of Patent: **** Mar. 14, 1995**

[54] **WEIGHT LIFTING SAFETY STAND**

[76] Inventor: **William C. Watts, 468 Halifax Dr., Coppell, Dallas County, Tex. 75019**

[**] Term: **14 Years**

[21] Appl. No.: **16,363**

[22] Filed: **Dec. 15, 1993**

[52] U.S. Cl. **D21/191**

[58] Field of Search **D21/191, 195; D6/495, D6/498, 499; 248/125, 188.91, 188.8; 482/130, 104, 106, 93, 94; D34/31**

4,618,142	10/1986	Joseph, Jr.	272/75
4,635,930	1/1987	Cormier	272/123
4,711,449	12/1987	Ochab	272/123
4,757,998	7/1988	Landin	272/123
4,773,642	9/1988	Cruz	482/104
4,799,673	1/1989	Selle	272/123
4,799,674	1/1989	Ochab	272/123
4,934,693	6/1990	Santoro	482/104
5,011,141	4/1991	Towley, III et al.	272/123
5,141,480	8/1992	Lennox et al.	482/104
5,217,421	6/1993	Chrysler	482/104
5,228,651	7/1993	Warner	D34/31
5,257,964	11/1993	Petters	482/93

[56] **References Cited**

U.S. PATENT DOCUMENTS

D. 265,111	6/1982	Lynn	D21/195
D. 278,753	5/1985	Honour, VII	D34/31
D. 288,509	3/1987	van de Oudeweetering	D6/499
D. 290,033	5/1987	Policastro	D21/198
1,699,707	1/1929	Mitchell .	
1,953,996	4/1934	Taylor	188/2
2,470,815	5/1949	Harvey	272/84
2,483,779	10/1949	Mucher	188/83
3,118,668	1/1964	Callahan	D21/197
3,189,347	6/1965	Dodge	272/81
3,382,953	5/1968	Wilkinson	188/78
3,756,597	9/1973	Monti	272/81
3,796,169	3/1974	Bales et al.	248/188.8
4,076,430	2/1978	Cook, Jr.	403/154
4,103,887	8/1978	Shoofler	272/123
4,153,244	5/1979	Tauber, Jr.	272/117
4,205,838	6/1980	McIntosh	272/123
4,239,169	12/1980	De Santis	248/125
4,252,314	2/1981	Ceppe	272/117
4,360,198	11/1982	Waulters	272/117
4,368,884	1/1983	Colvin	272/123
4,369,968	1/1983	Price	272/123
4,411,425	10/1983	Milnar	272/123

OTHER PUBLICATIONS

"Incline Power and Crunch Bench" *Coach and Athlete*, Mar.1992, vol. 44, No. 5, p. 49.

Primary Examiner—Bernard Ansher
Assistant Examiner—Philip Hyder
Attorney, Agent, or Firm—Richards, Medlock & Andrews

[57] **CLAIM**

The ornamental design for a weight lifting safety stand, as shown and described.

DESCRIPTION

FIG. 1 is a perspective view of a weight lifting safety stand embodying my design;
FIG. 2 is a front elevational view thereof;
FIG. 3 is a rear elevational view thereof;
FIG. 4 is a left side elevational view thereof;
FIG. 5 is a right side elevational view thereof;
FIG. 6 is a top plan view thereof; and,
FIG. 7 is a bottom view thereof.
The broken line portions of the drawing are for illustrative purposes only and forms no part of the claimed design.

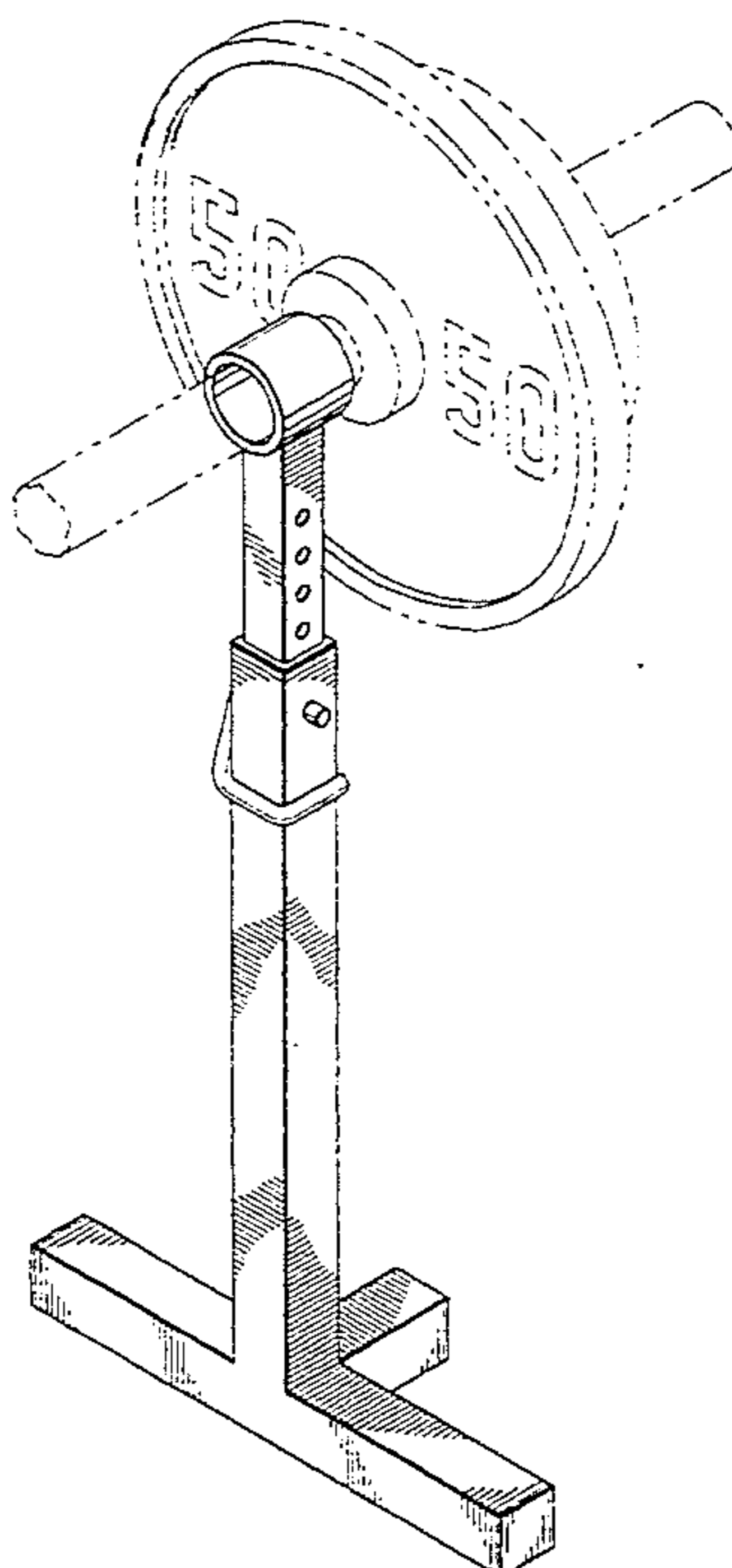

FIG. 1

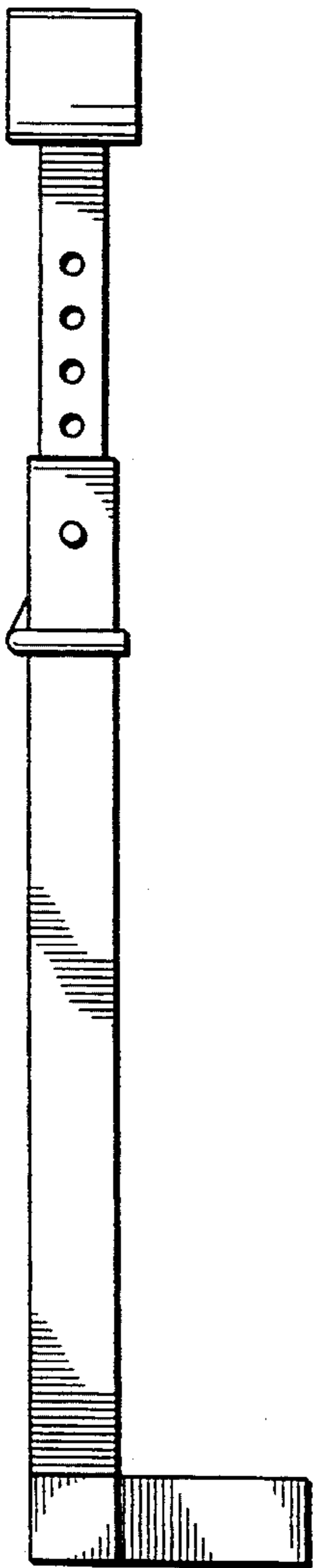
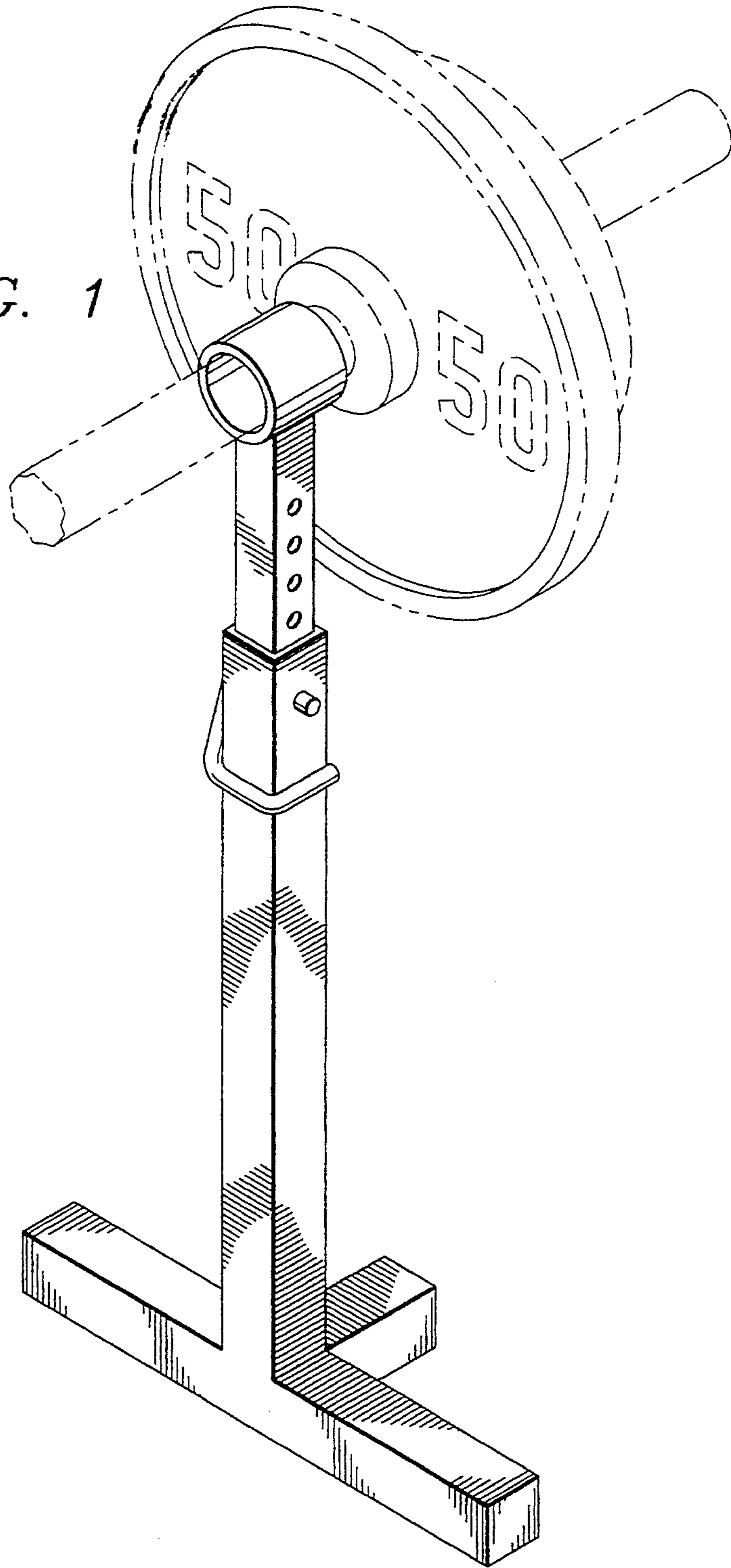

FIG. 2

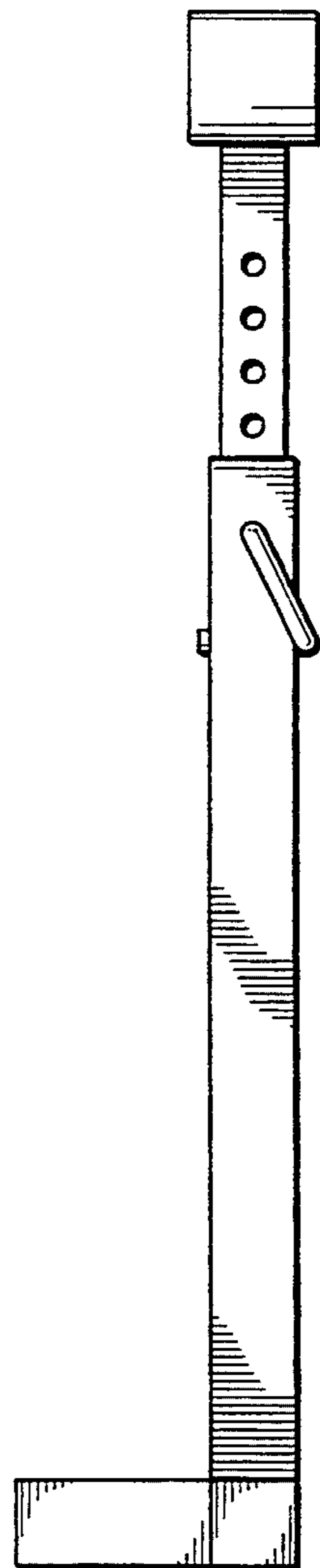

FIG. 3

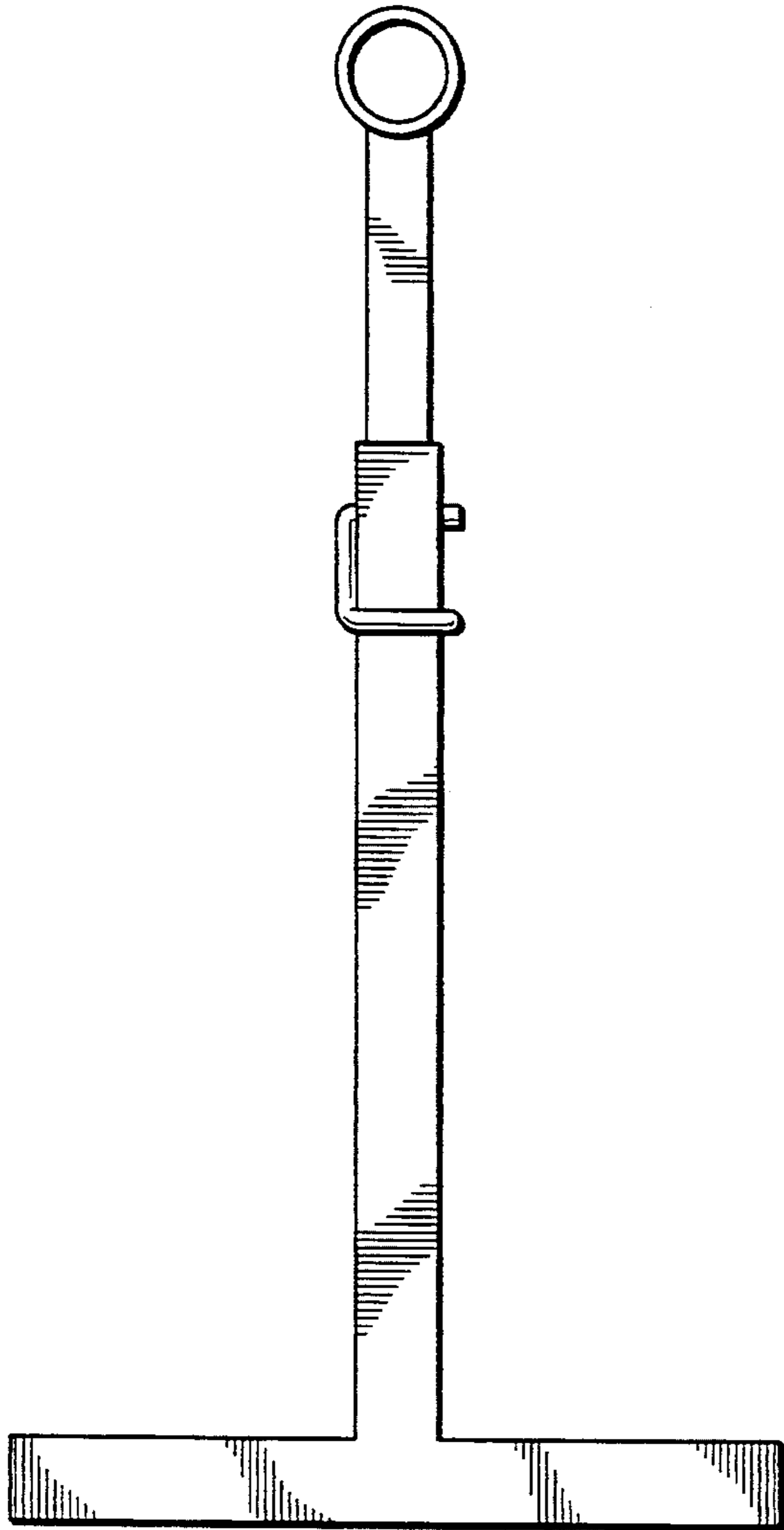

FIG. 4

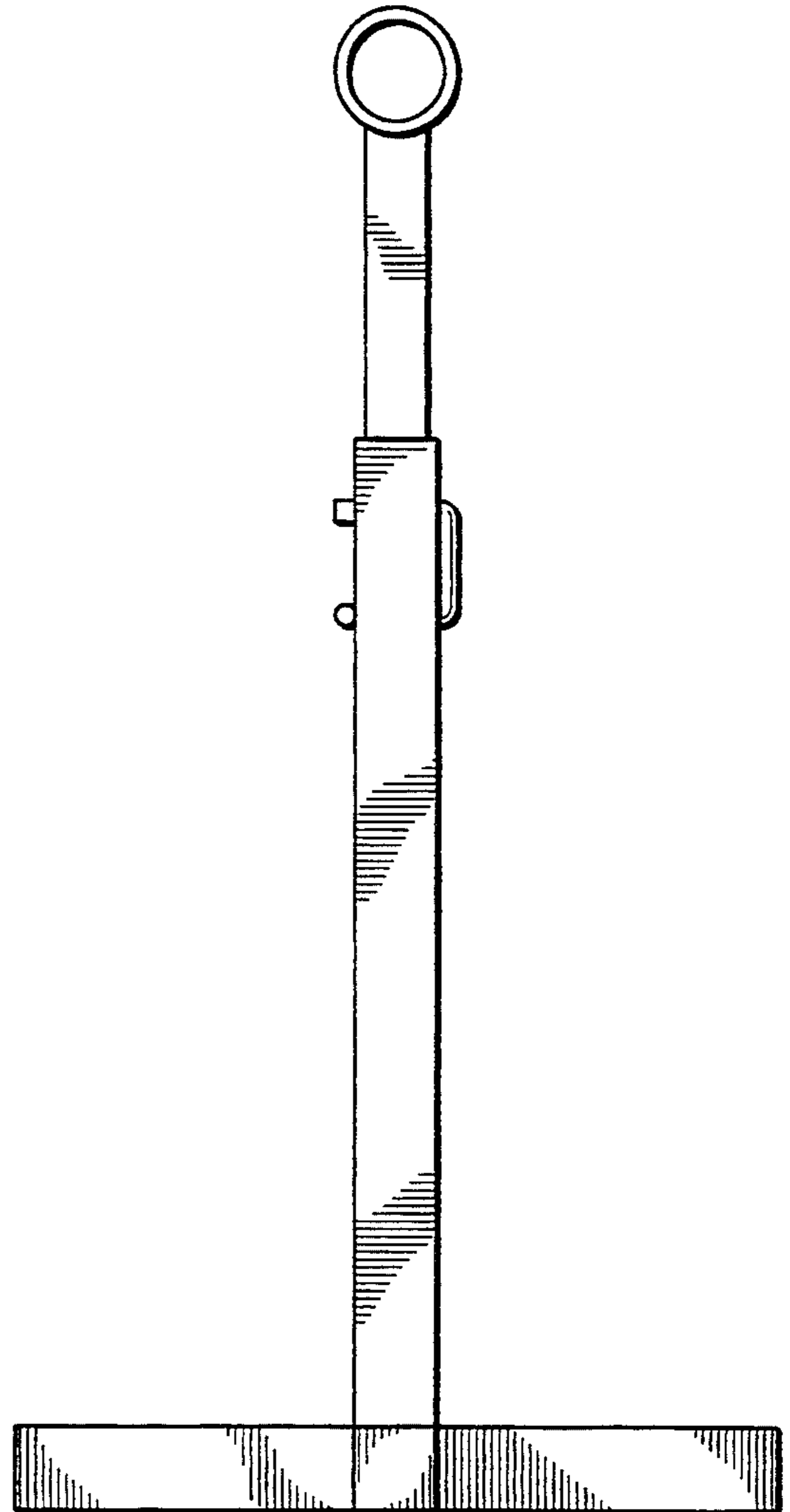

FIG. 5

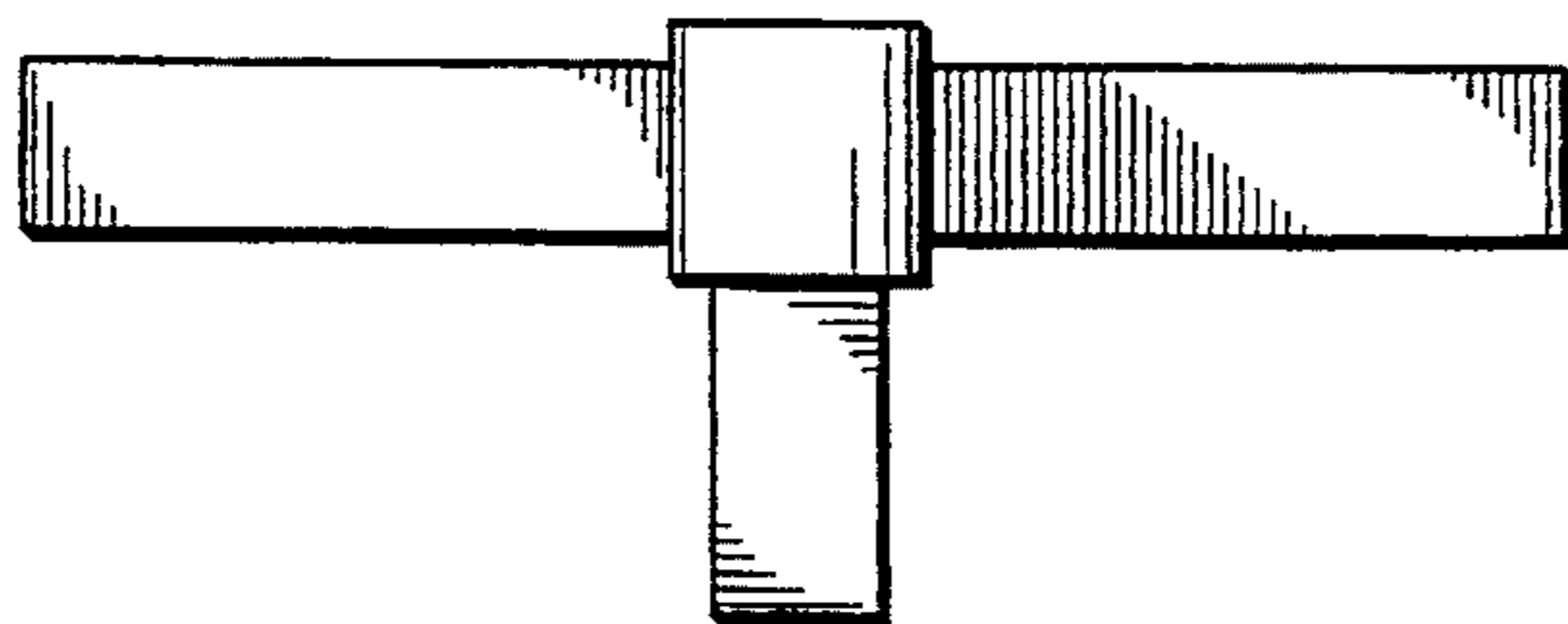

FIG. 6

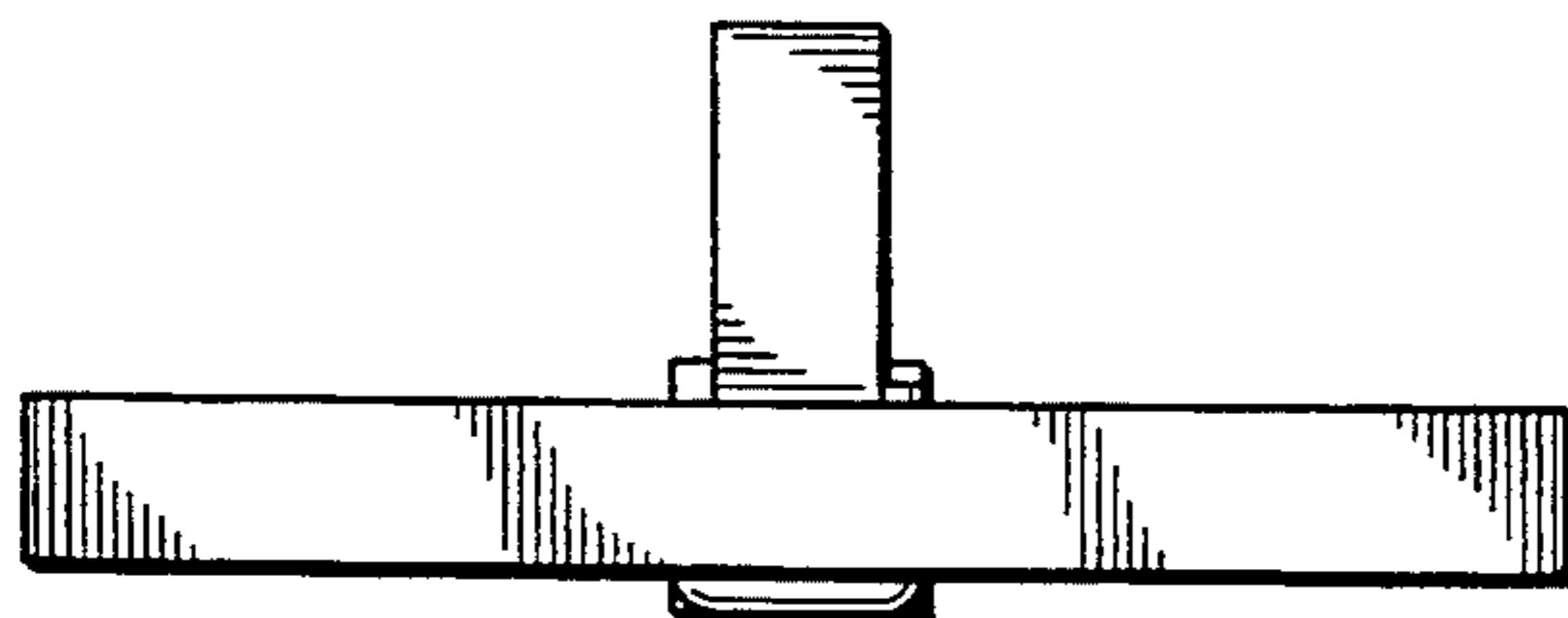

FIG. 7