



US00D356242S

United States Patent [19]

[11] Patent Number: **Des. 356,242**

Lo

[45] Date of Patent: **** Mar. 14, 1995**

[54] **AUTOMOBILE STEERING LOCK**

[76] Inventor: **Tsung-I Lo**, 5th Fl. No. 76, Ai-Kuo E. Rd., Taipei, Taiwan, Prov. of China

[**] Term: **14 Years**

[21] Appl. No.: **23,950**

[22] Filed: **Jun. 3, 1994**

[52] U.S. Cl. **D8/331**

[58] Field of Search **D8/330-331, D8/339, 341; 70/207-211, 214-215, 225-226, 237-238; 292/289**

[56] **References Cited**

U.S. PATENT DOCUMENTS

- D. 330,500 10/1992 Chen D8/331
- D. 348,206 6/1994 Chen D8/331

- D. 350,274 9/1994 Baker D8/331
- 4,829,797 5/1989 Wu 70/209
- 5,052,201 10/1991 Liou 70/209
- 5,095,723 3/1992 Lin 70/209 X
- 5,115,652 5/1992 Starmer 70/209

Primary Examiner—Brian N. Vinson

[57] **CLAIM**

The ornamental design for an automobile steering lock, as shown and described.

DESCRIPTION

FIG. 1 is a top, front, and left side perspective view of automobile steering lock showing my new design;
 FIG. 2 is an end view thereof;
 FIG. 3 is an opposite end view thereof;
 FIG. 4 is a side view thereof;
 FIG. 5 is an opposite side view thereof;
 FIG. 6 is a plan view thereof; and,
 FIG. 7 is an underneath plan view thereof.

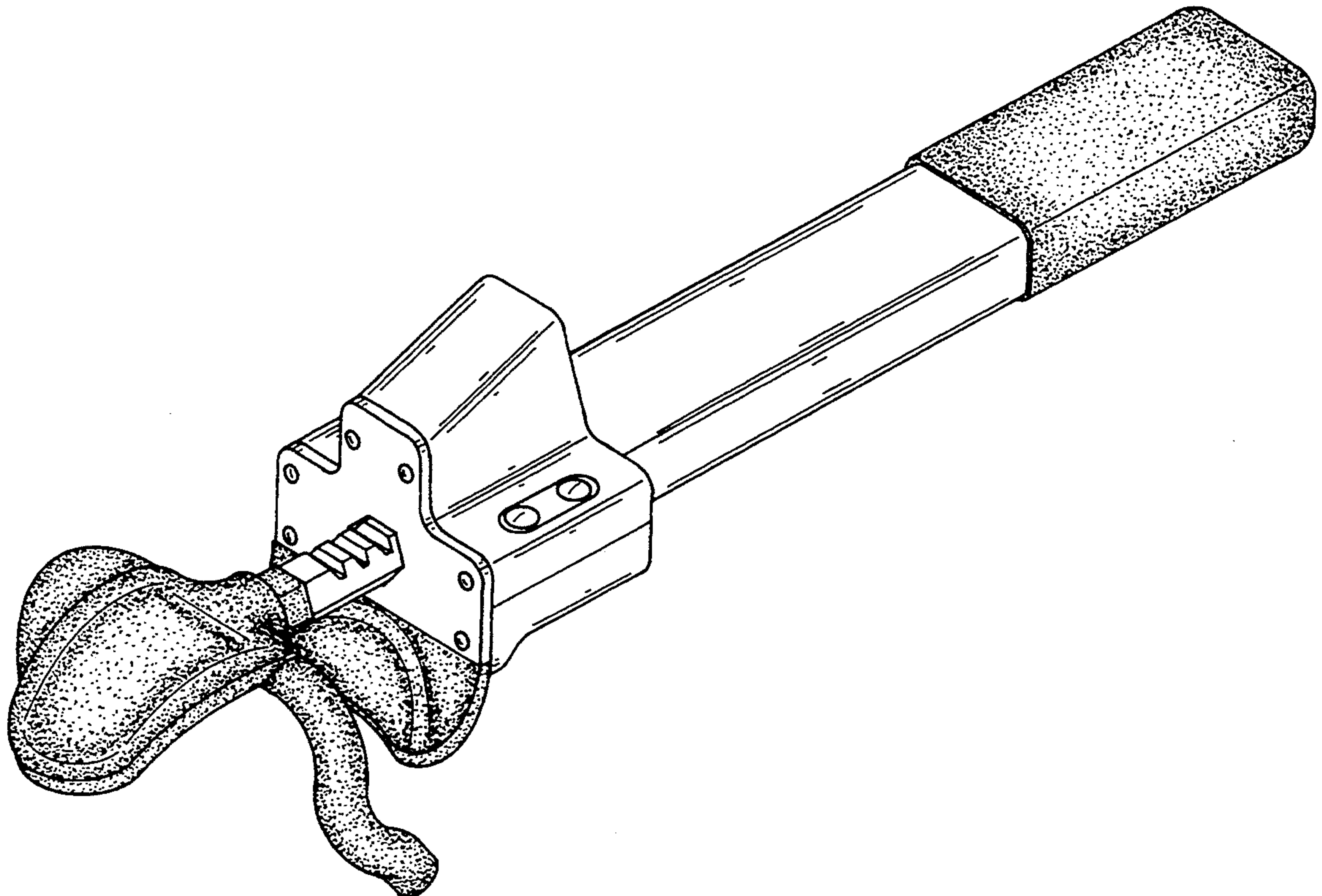

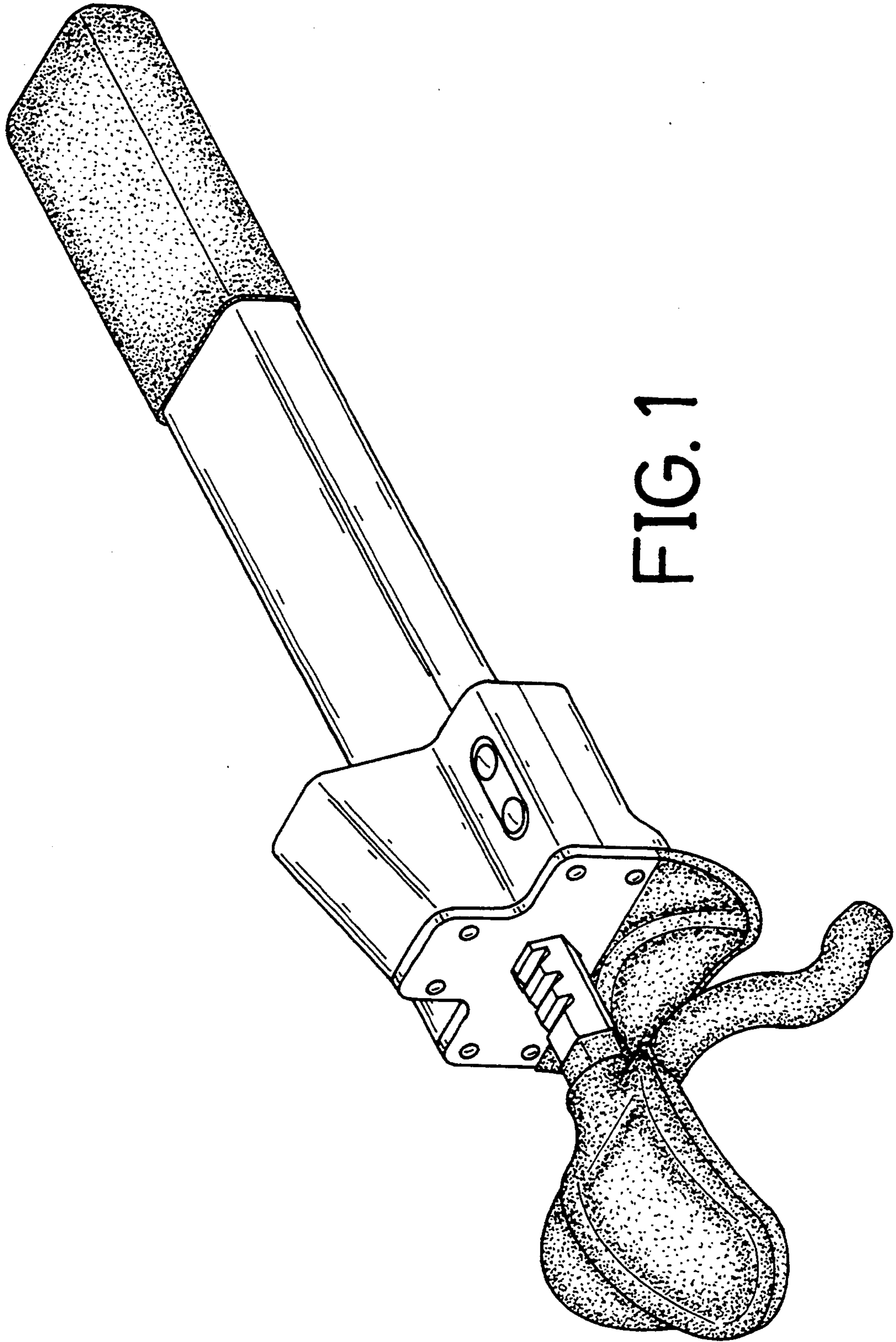

FIG. 1

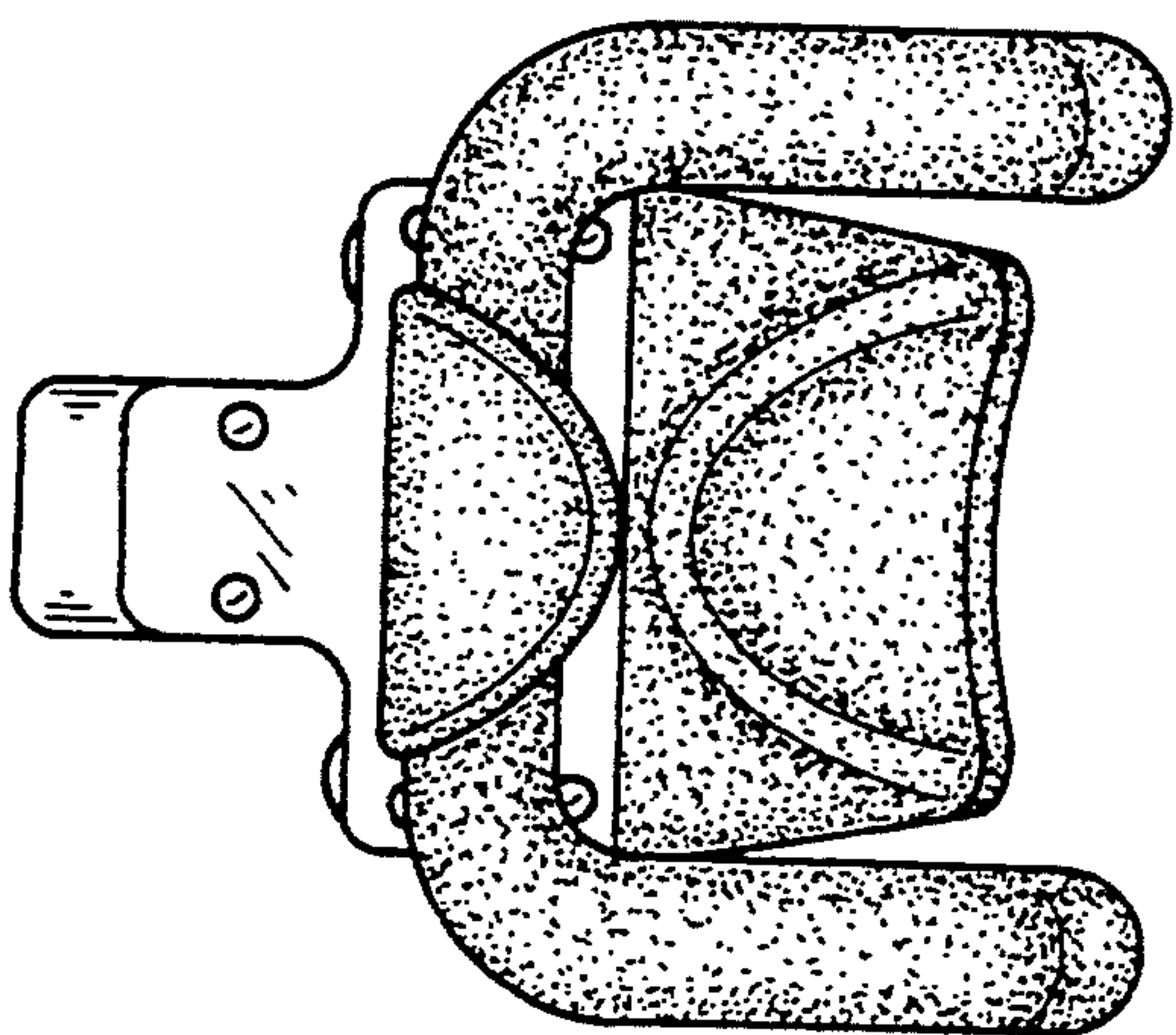

FIG. 2

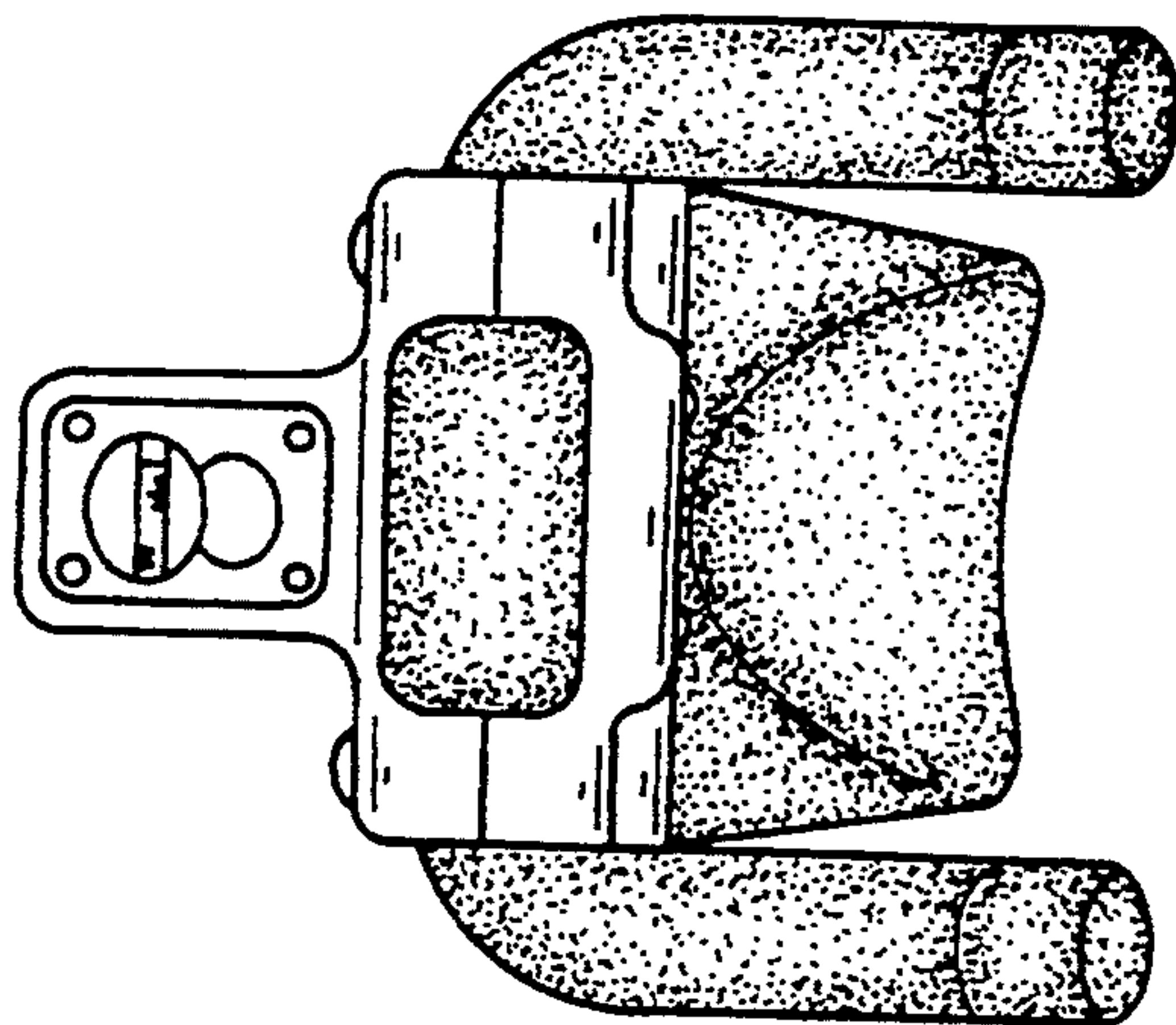

FIG. 3

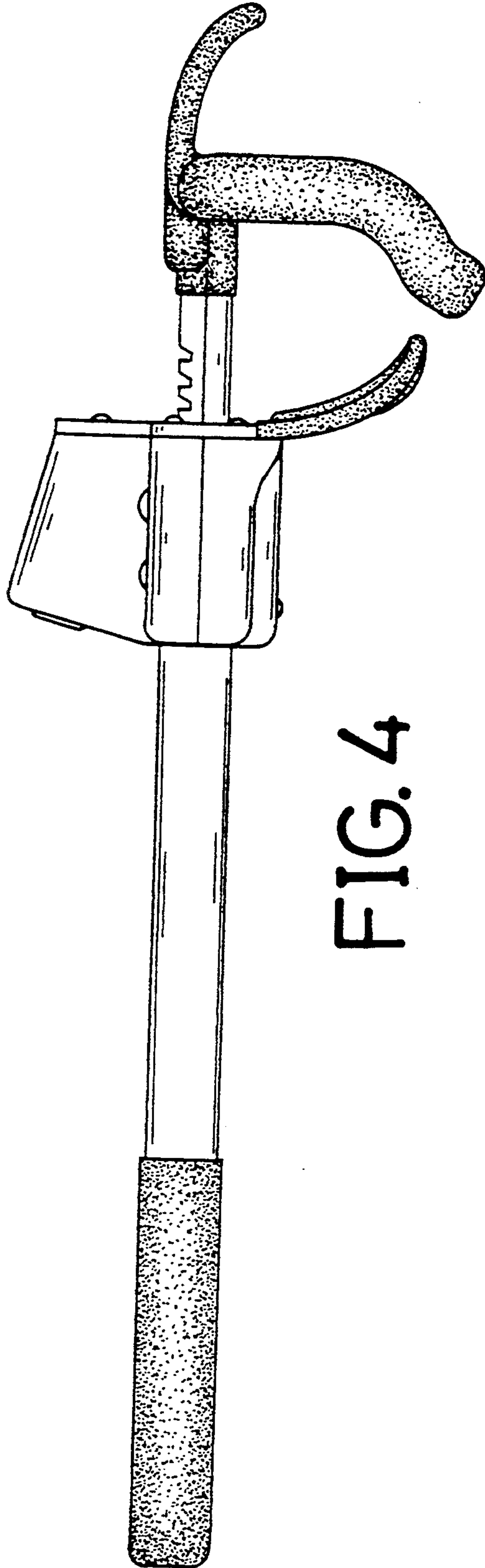

FIG. 4

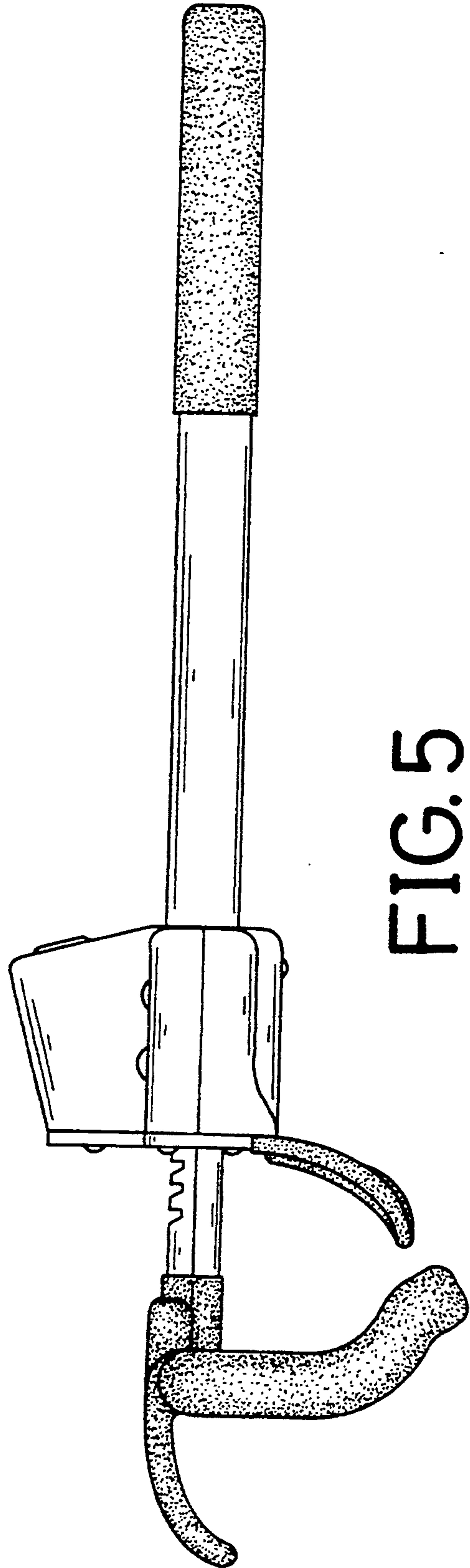

FIG. 5

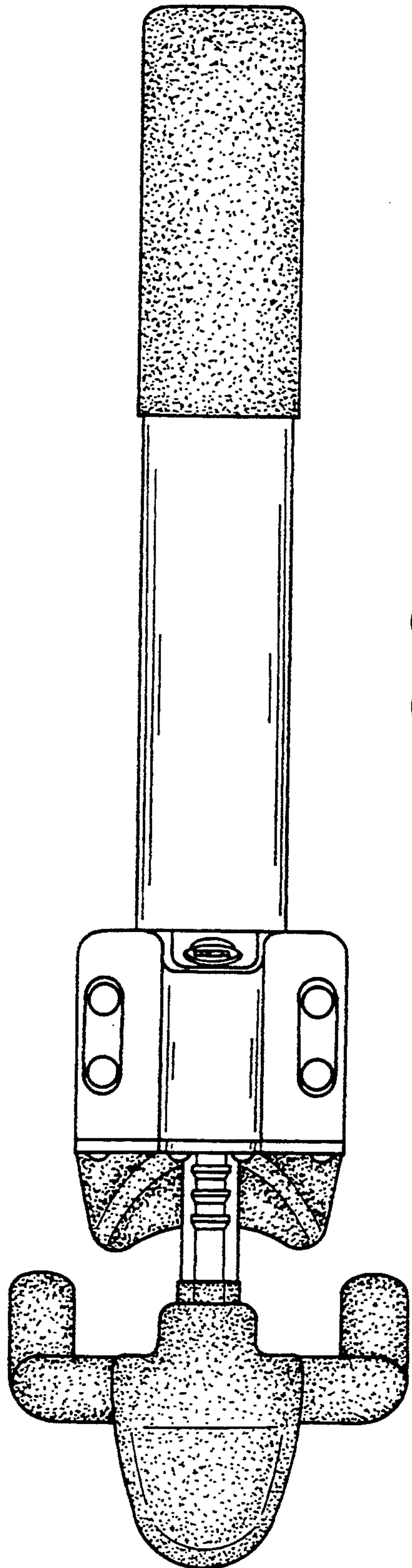

FIG. 6

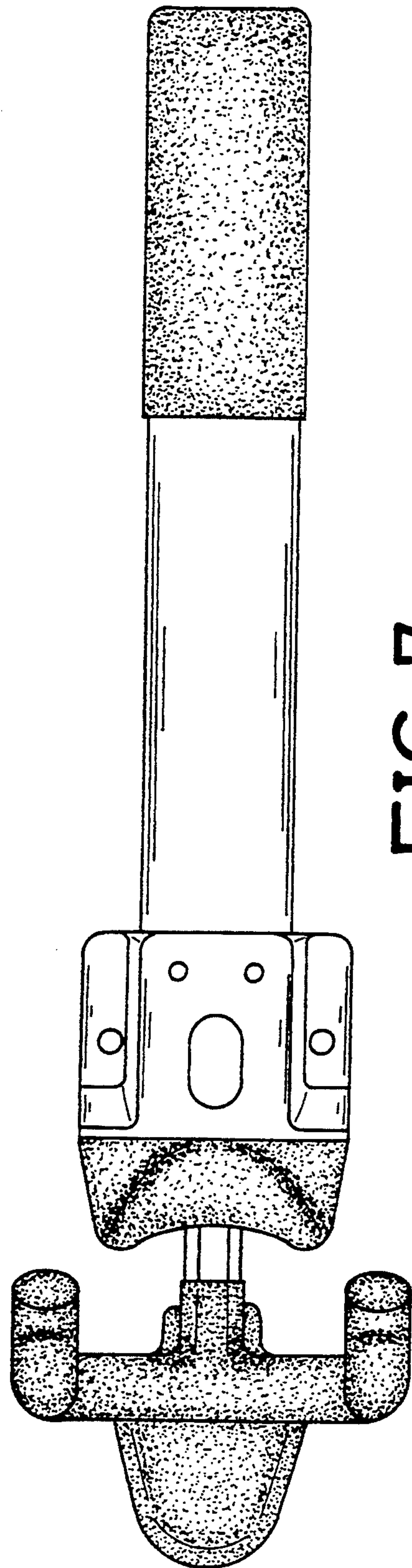

FIG. 7