



US00D356201S

# United States Patent [19]

[11] Patent Number: **Des. 356,201**

Sato et al.

[45] Date of Patent: **\*\* Mar. 7, 1995**

[54] **FORK LIFT TRUCK**

4,688,981 8/1987 Rausborg etal. .... 414/607

[75] Inventors: **Yoshitaka Sato; Toshihiro Nishio,**  
both of Kariya, Japan

*Primary Examiner*—Wallace R. Burke  
*Assistant Examiner*—Robin V. Taylor  
*Attorney, Agent, or Firm*—Brooks Haidt Haffner &  
Delahunty

[73] Assignee: **Kabushiki Kaisha Toyota Jidoshokki**  
**Seisakusho, Kariya, Japan**

[57] **CLAIM**

[\*\*] Term: **14 Years**

The ornamental design for a fork lift truck, as shown  
and described.

[21] Appl. No.: **13,466**

[22] Filed: **Sep. 24, 1993**

**DESCRIPTION**

[30] **Foreign Application Priority Data**

Mar. 30, 1993 [JP] Japan ..... 5-9300

Apr. 2, 1993 [JP] Japan ..... 5-9804

[52] **U.S. Cl.** ..... **D34/28**

[58] **Field of Search** ..... **D34/28, 34, 37;**  
**414/529, 785, 607; 180/89.12, 89.14, 89.17**

FIG. 1 is a front elevational view of a fork lift truck  
showing our new design;

FIG. 2 is a rear view thereof;

FIG. 3 is a top plan view thereof;

FIG. 4 is a bottom plan view thereof;

FIG. 5 is a left side view thereof;

FIG. 6 is a right side view thereof;

FIG. 7 is a front perspective view thereof;

FIG. 8 is a rear perspective view thereof;

FIG. 9 is a front elevational view of a second embodi-  
ment thereof;

FIG. 10 is a rear view thereof;

FIG. 11 is a top plan view thereof;

FIG. 12 is a bottom plan view thereof;

FIG. 13 is a left side view thereof;

FIG. 14 is a right side view thereof;

FIG. 15 is a front perspective view thereof; and,

FIG. 16 is a rear perspective view thereof.

[56] **References Cited**

**U.S. PATENT DOCUMENTS**

D. 174,112 3/1955 de Sakhroffsky ..... D34/34

D. 231,340 4/1974 Haynes ..... D34/34

D. 234,050 1/1975 Crawford et al. .... D34/34

D. 338,764 8/1993 Furuta ..... D34/34

3,713,688 1/1973 Monroe ..... D34/34

3,754,673 8/1973 Barda et al. .... 414/785

3,893,579 7/1975 Glewwe ..... 414/607

4,043,472 8/1977 Hoyt ..... 414/785

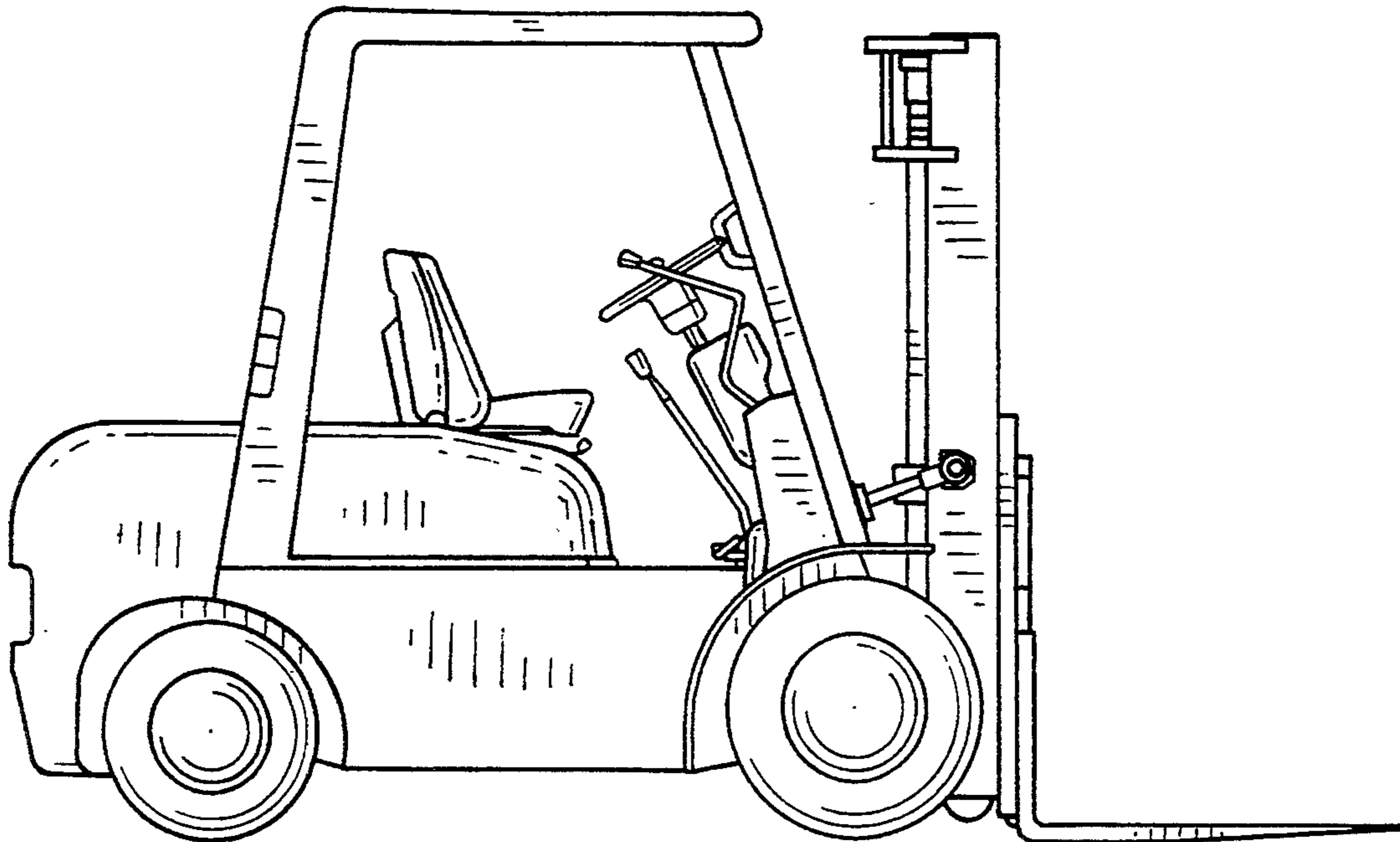

FIG. 1

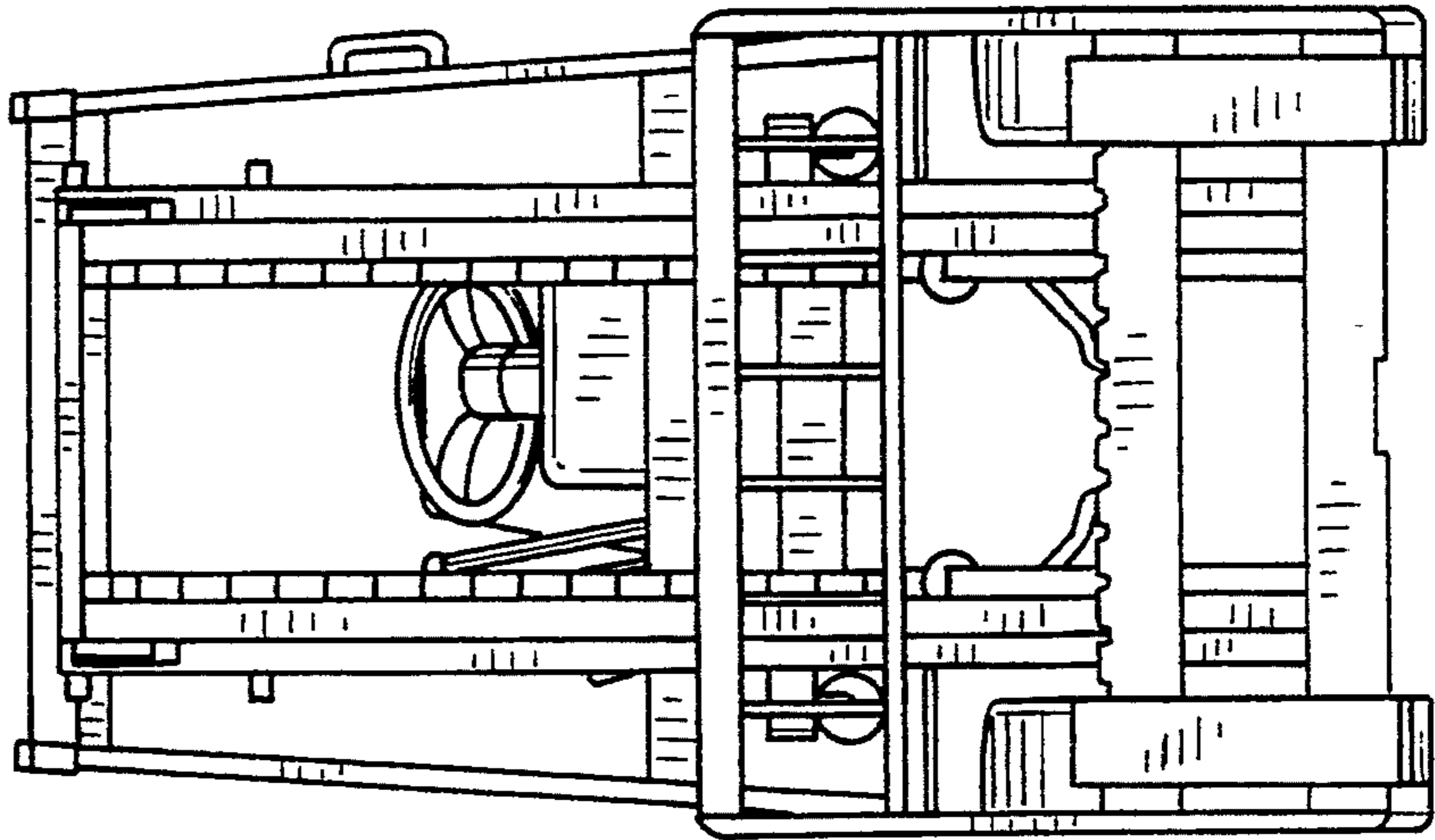

FIG. 2

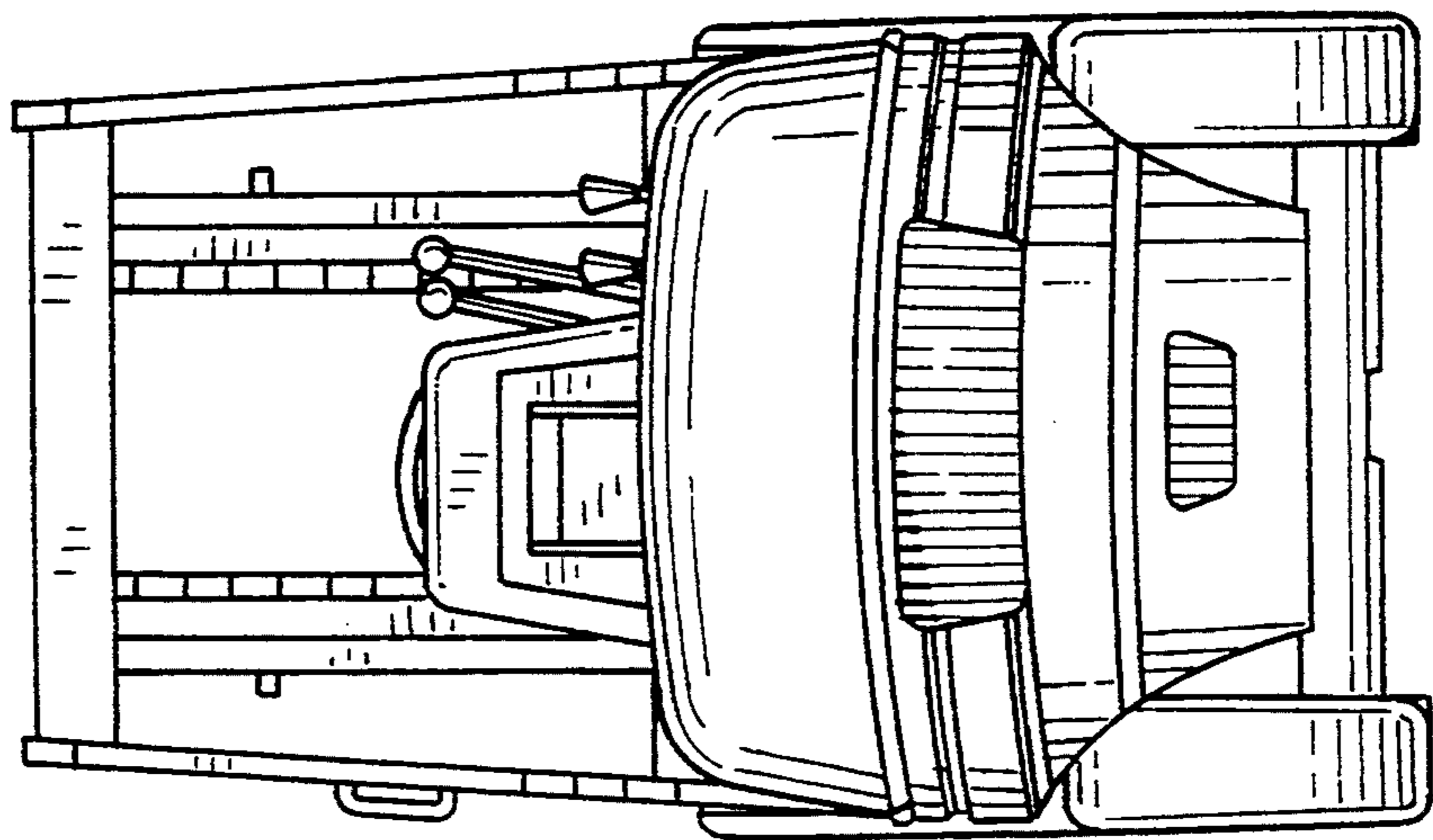

FIG. 4

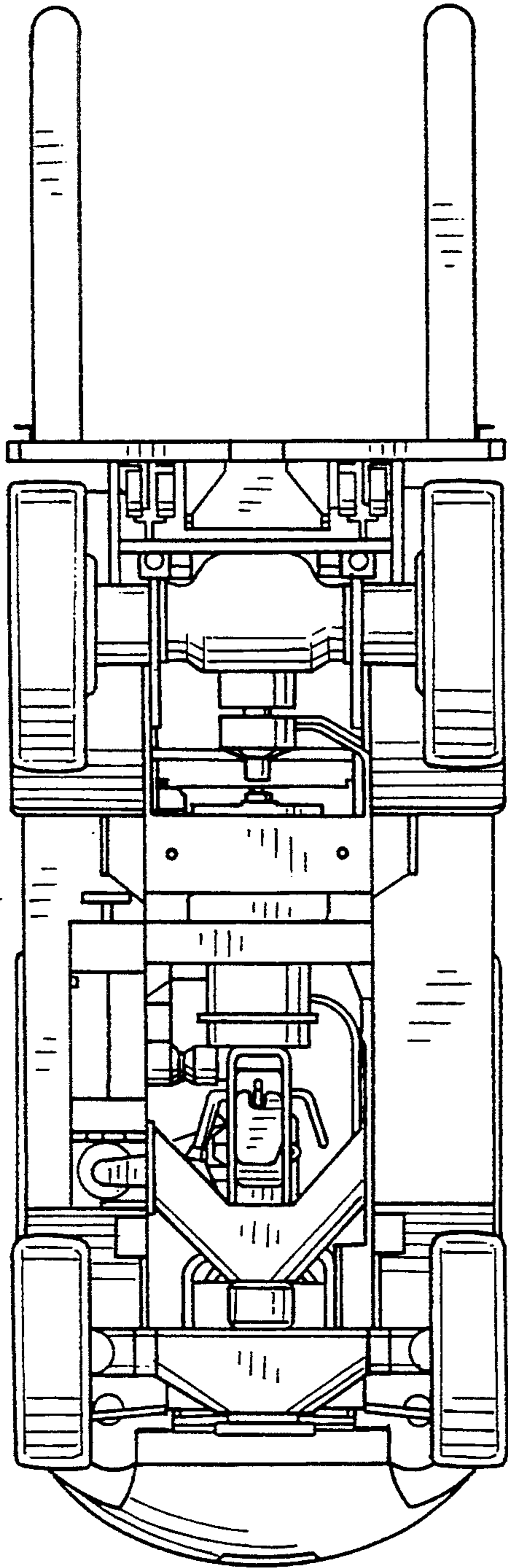

FIG. 3

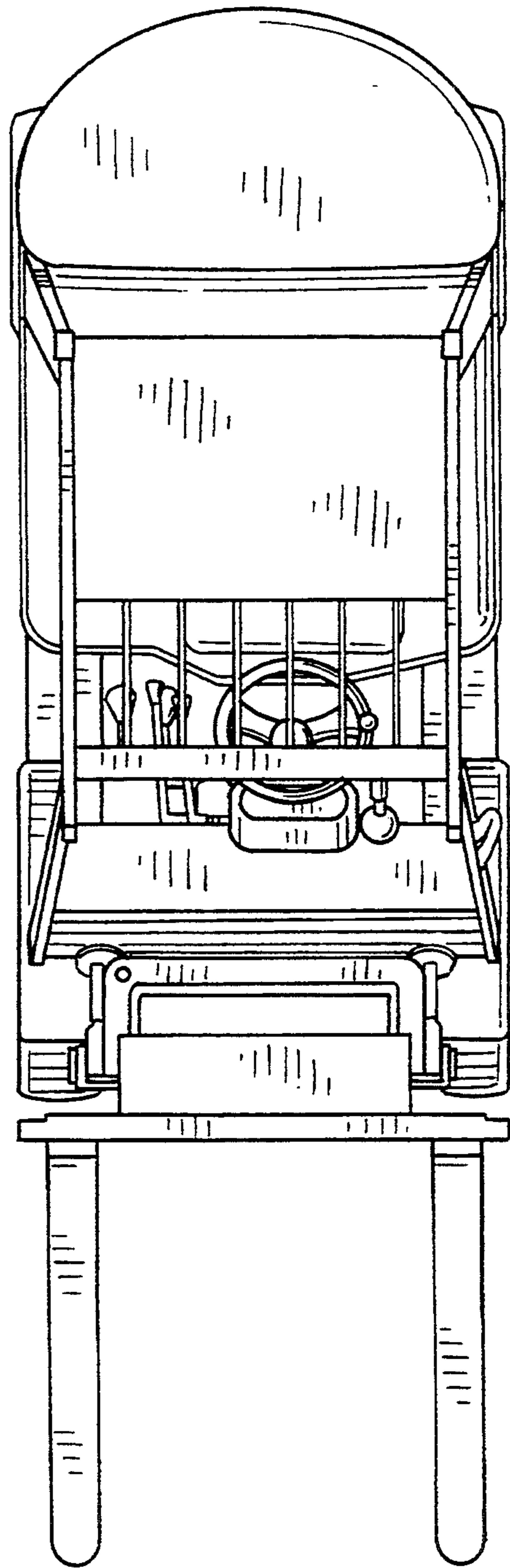



FIG. 5

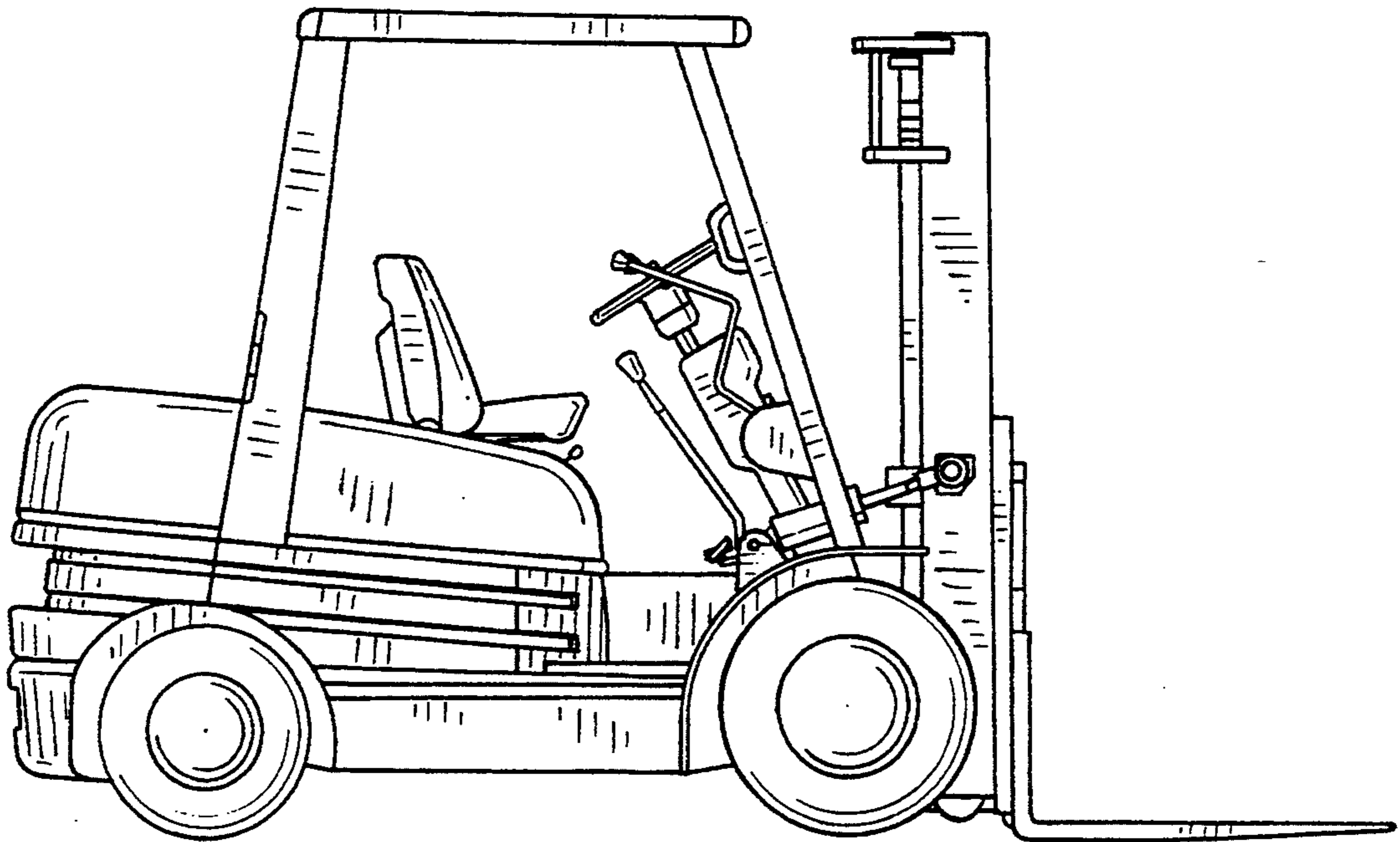

FIG. 6

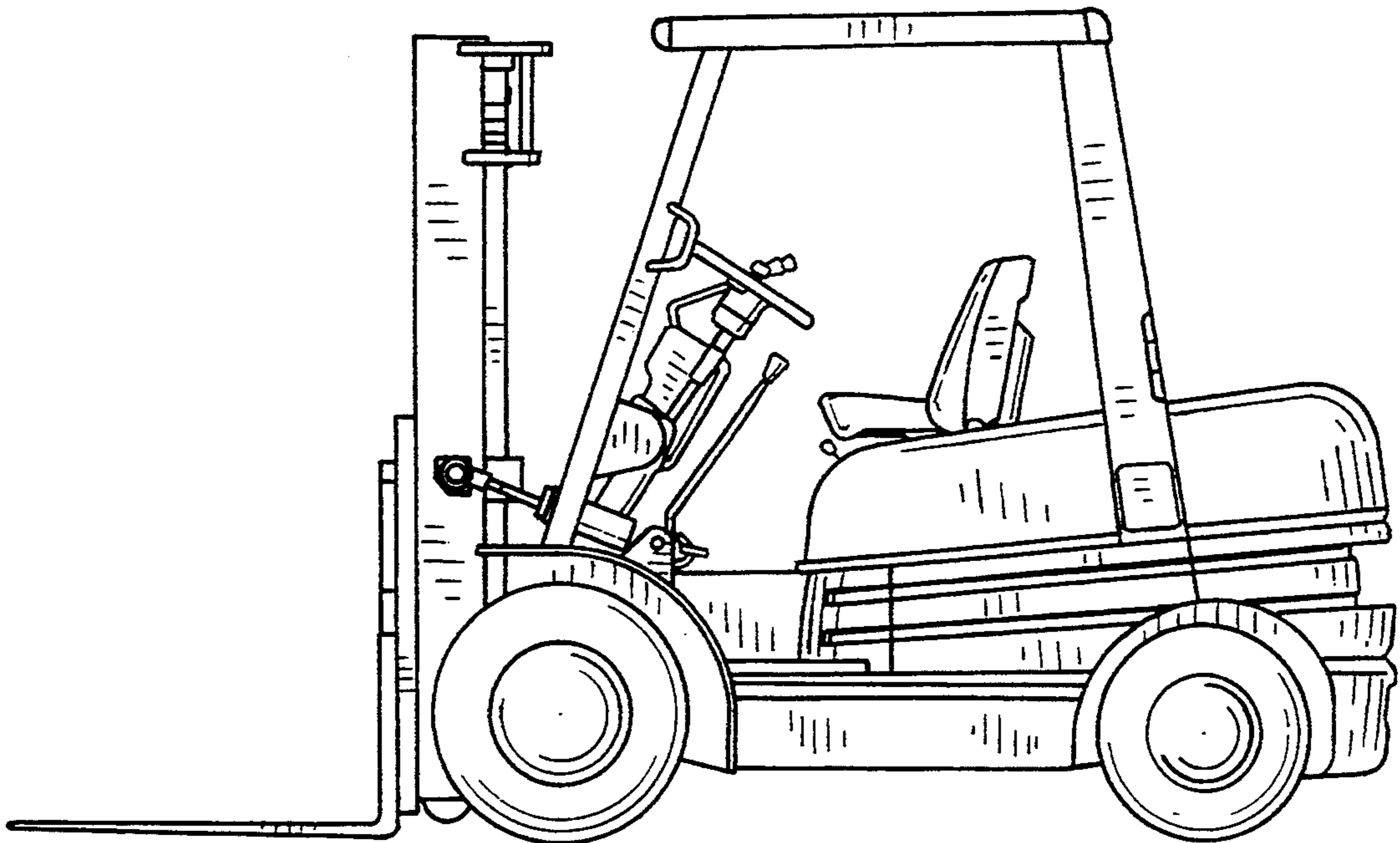

FIG. 7

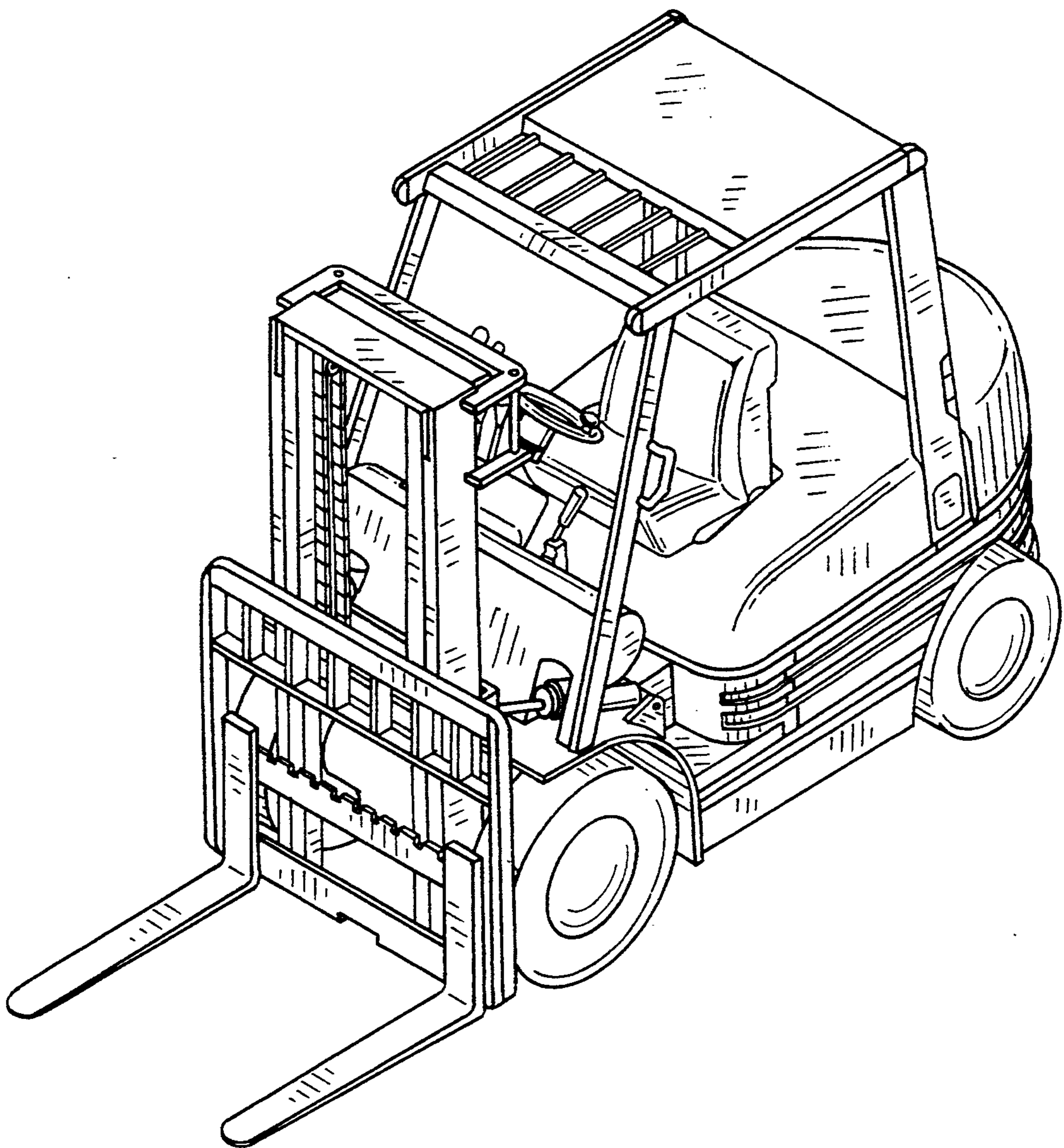

FIG. 8

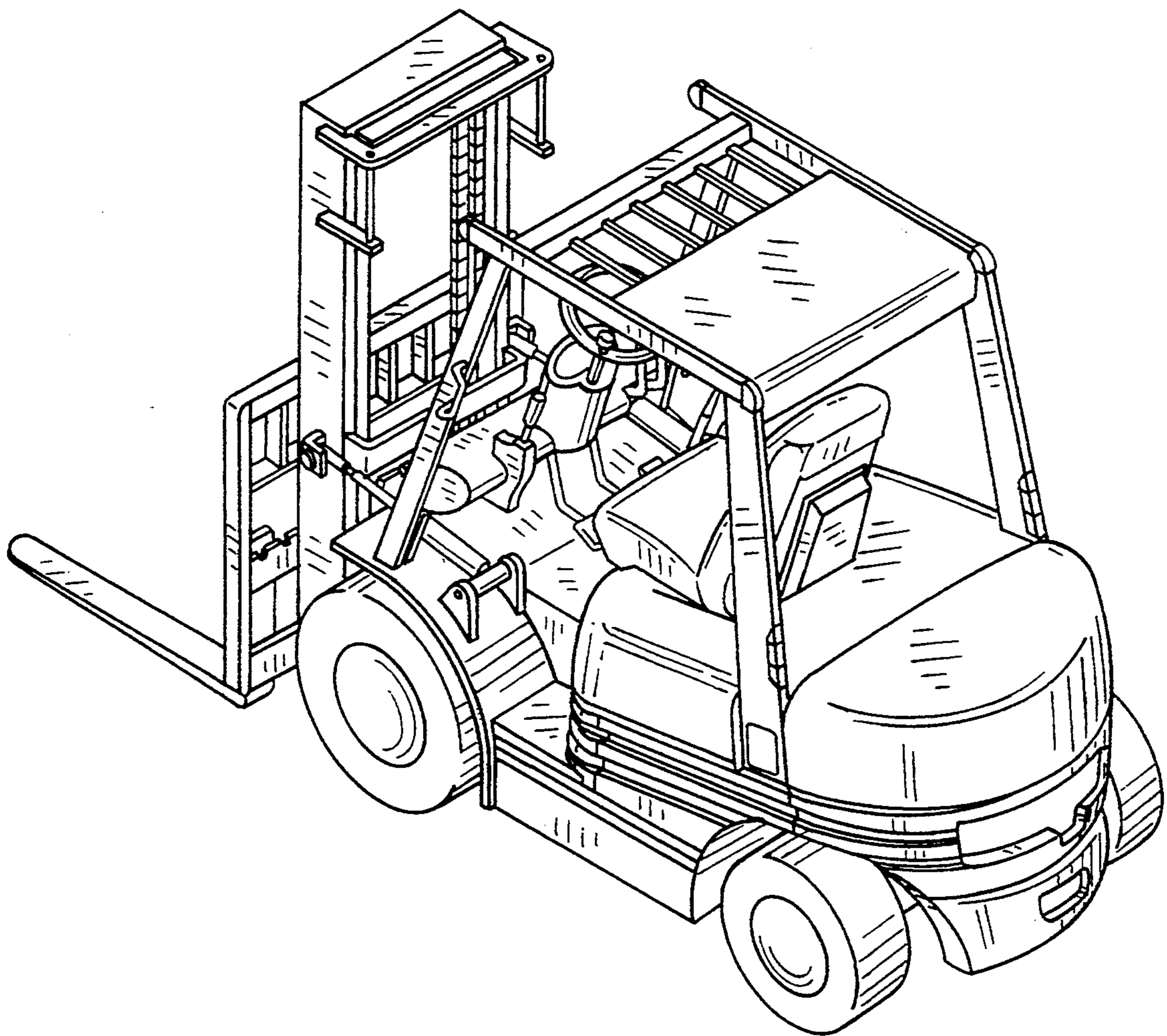



FIG. 9

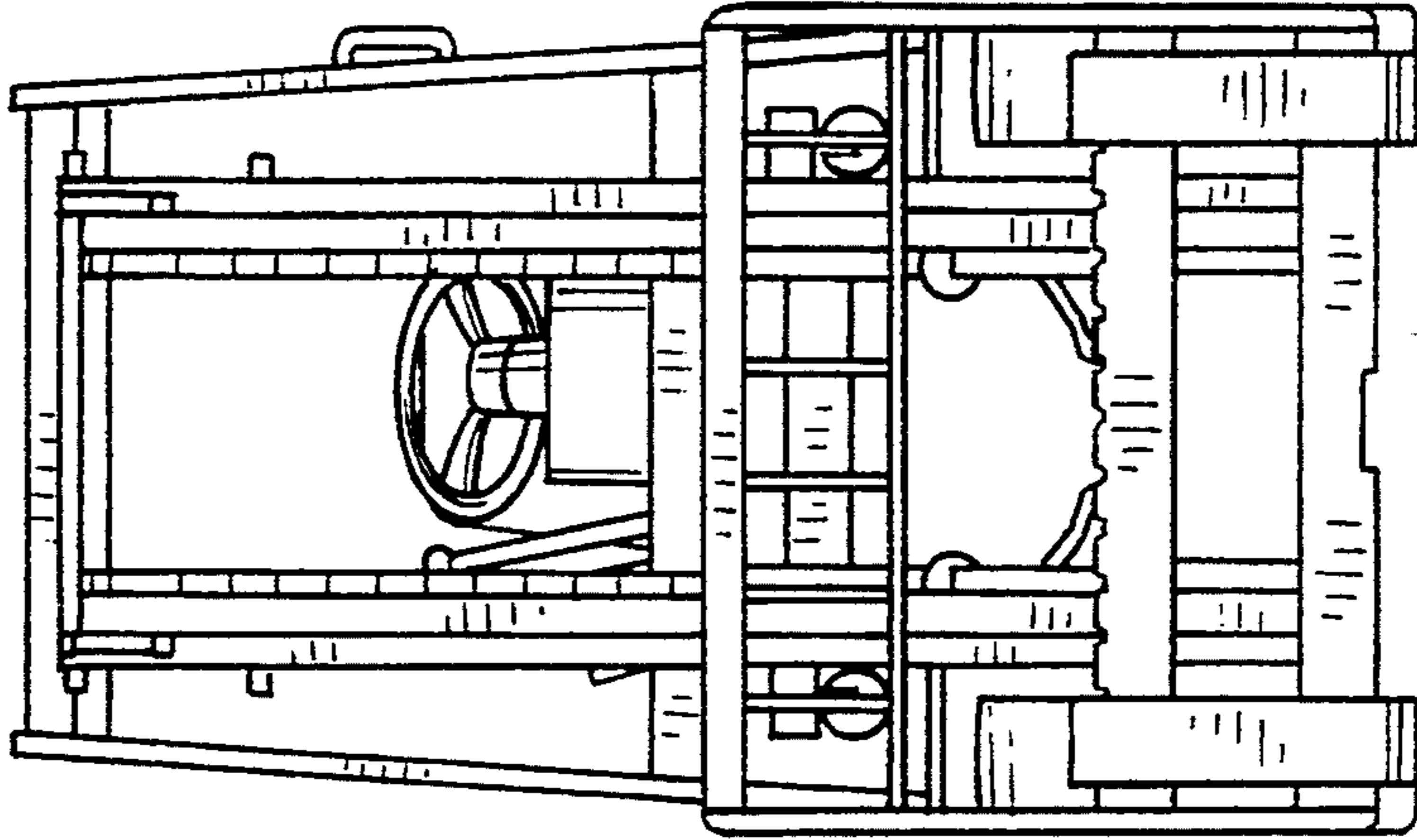

FIG. 10

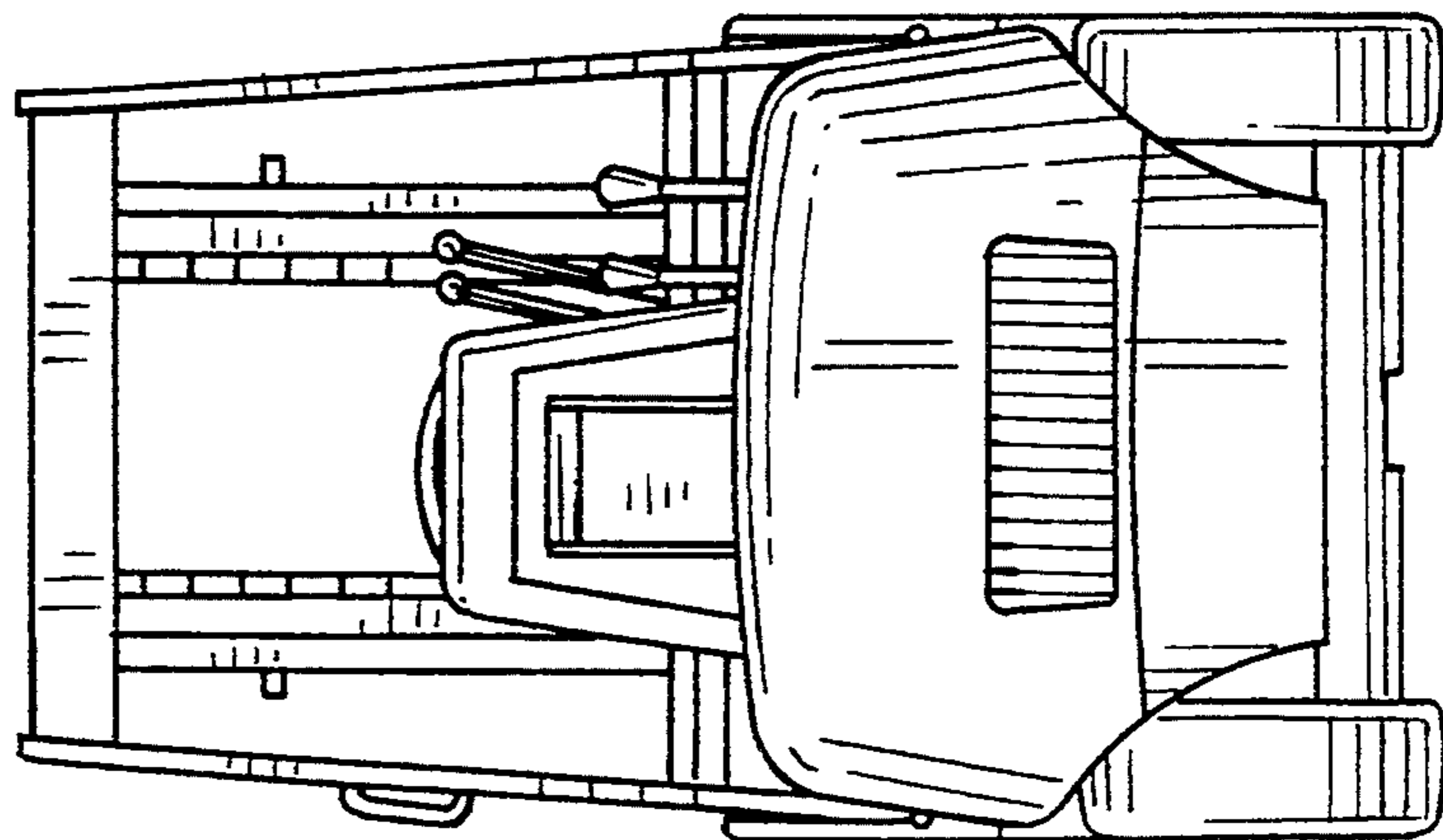

FIG. 12

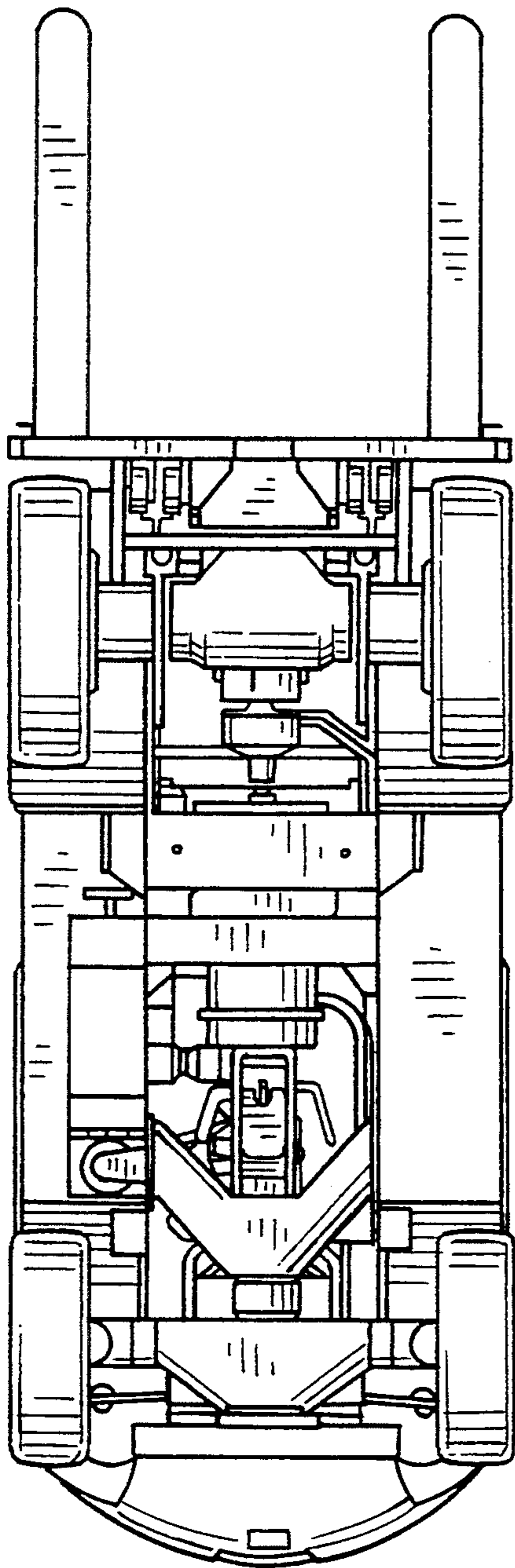

FIG. 11

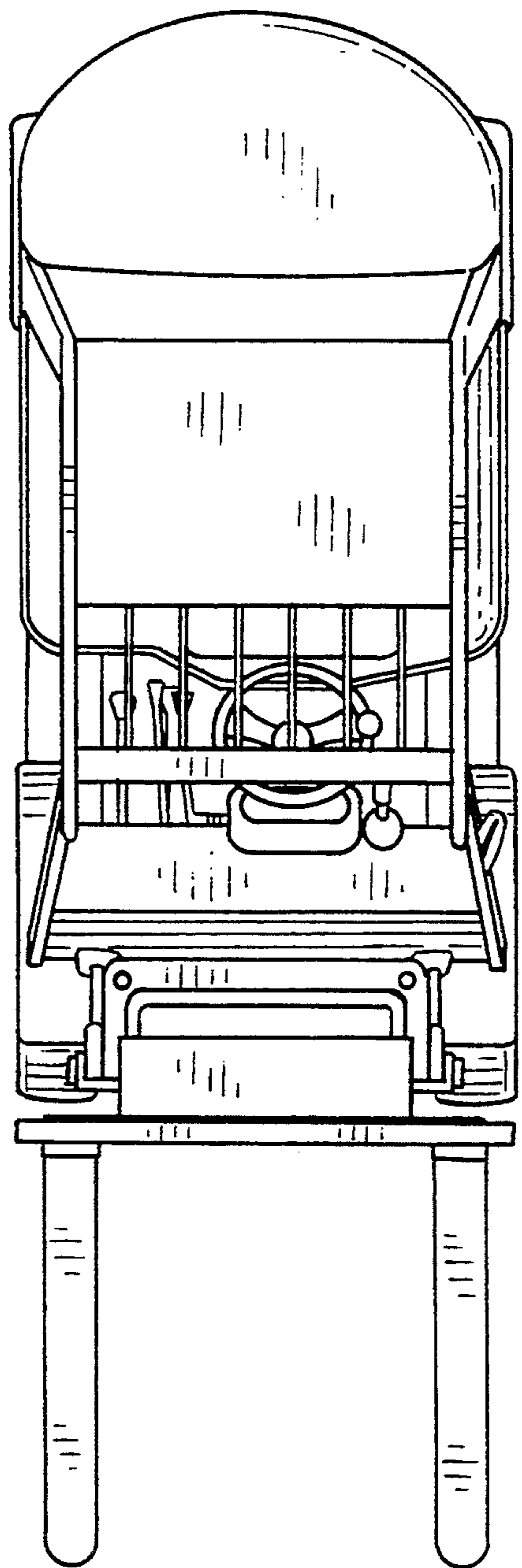



FIG. 13

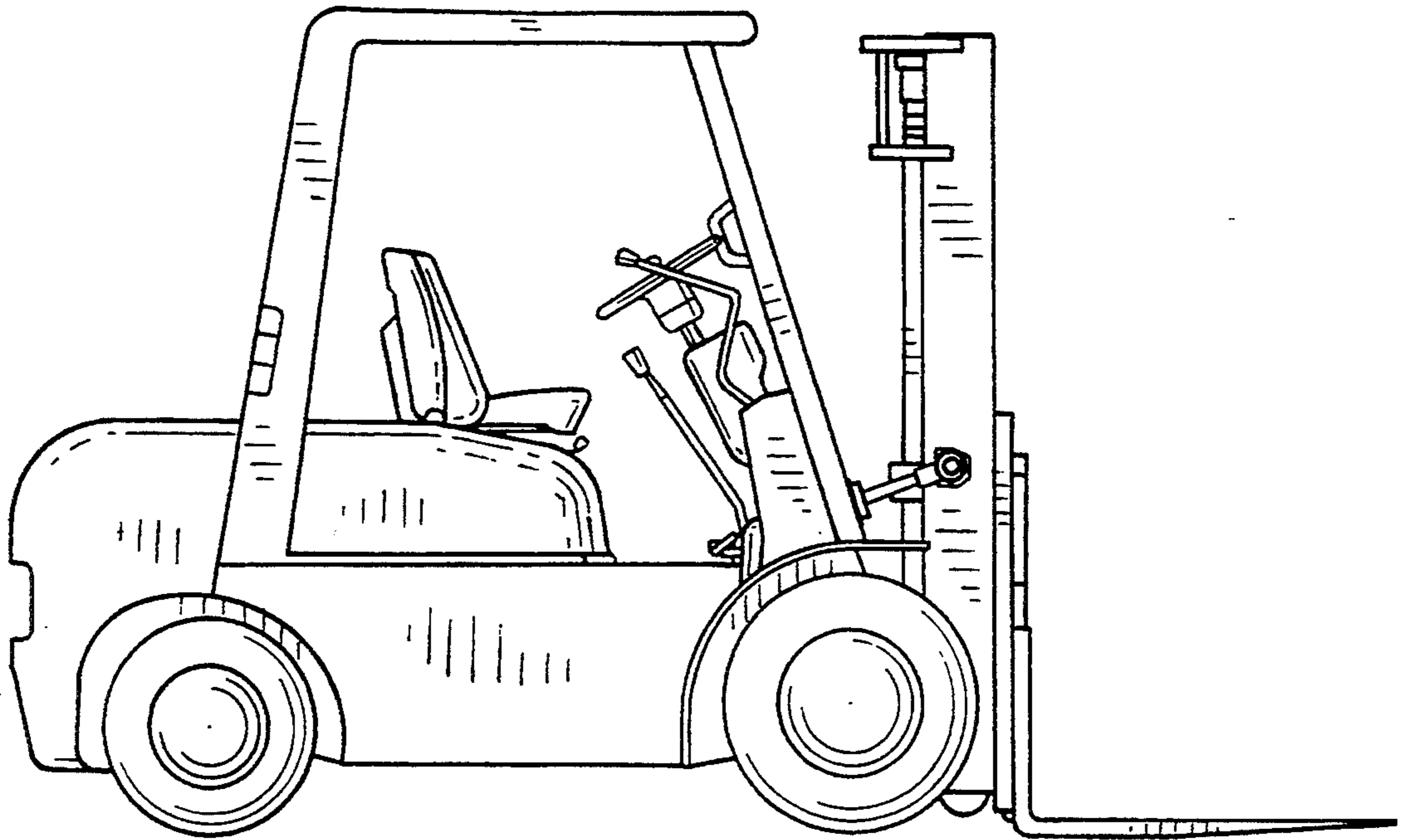

FIG. 14

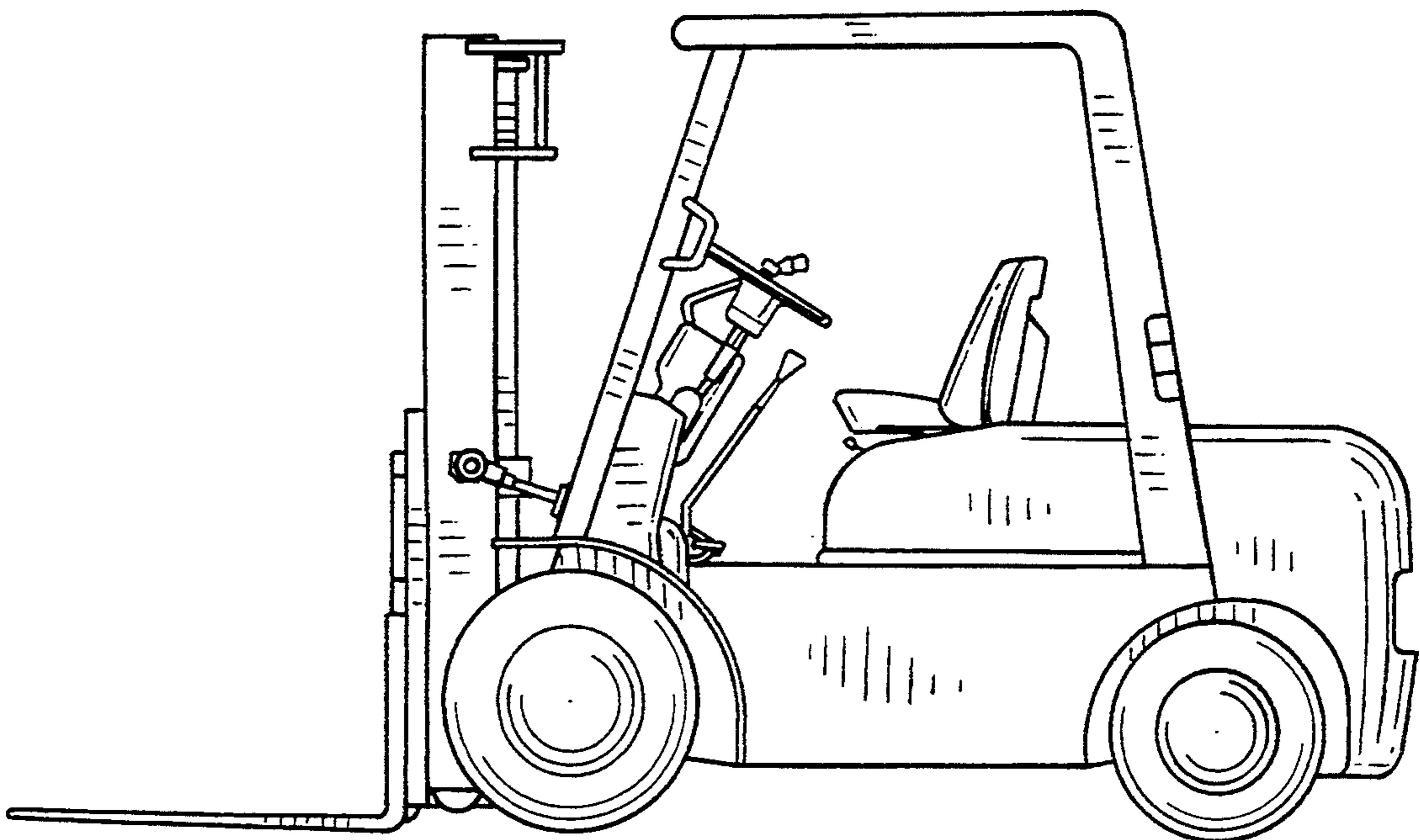

FIG. 15

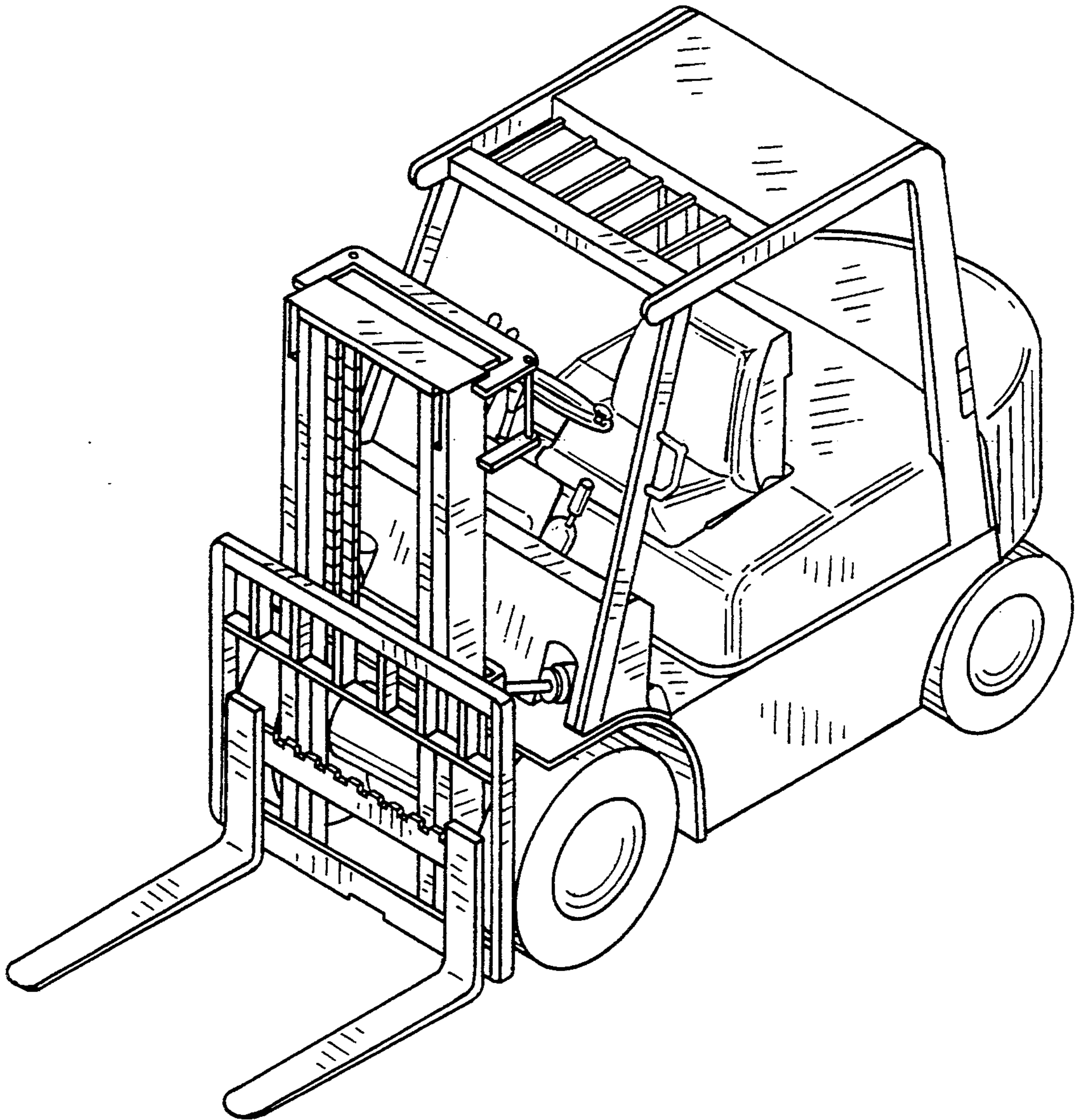

FIG. 16

