



US00D356197S

United States Patent [19]

[11] Patent Number: **Des. 356,197**

Loughlin

[45] Date of Patent: **** Mar. 7, 1995**

[54] **HAND TRUCK**

3,791,542 2/1974 Mauch D34/26
5,253,881 10/1993 Dunkle 280/5.22

[76] Inventor: **Stephen C. Loughlin**, Ste. 446, 8120
Penn Ave., Bloomington, Minn.
55431

Primary Examiner—Kay H. Chin
Attorney, Agent, or Firm—Leo Gregory

[**] Term: **14 Years**

[57] **CLAIM**

[21] Appl. No.: **20,146**

The ornamental design for a hand truck, as shown and described.

[22] Filed: **Mar. 21, 1994**

[52] U.S. Cl. **D34/12; D34/26**

[58] Field of Search D34/12, 24, 25, 26;
280/5.22, 47.27, 654; 180/9.22

DESCRIPTION

FIG. 1 is a right side elevational view of a hand truck showing my new design;

FIG. 2 is a front elevational view thereof;

FIG. 3 is a rear elevational view thereof;

FIG. 4 is a cross sectional view thereof taken along the line 4—4 of FIG. 3;

FIG. 5 is a bottom plan view thereof;

FIG. 6 is a top plan view thereof; and,

FIG. 7 is a view in perspective thereof.

[56] References Cited

U.S. PATENT DOCUMENTS

D. 327,761 7/1992 Stanfield D34/26
D. 336,710 6/1993 Kinnaman D34/26
2,770,310 11/1956 Gates 280/5.22
3,647,236 3/1972 Hayes 280/47.27

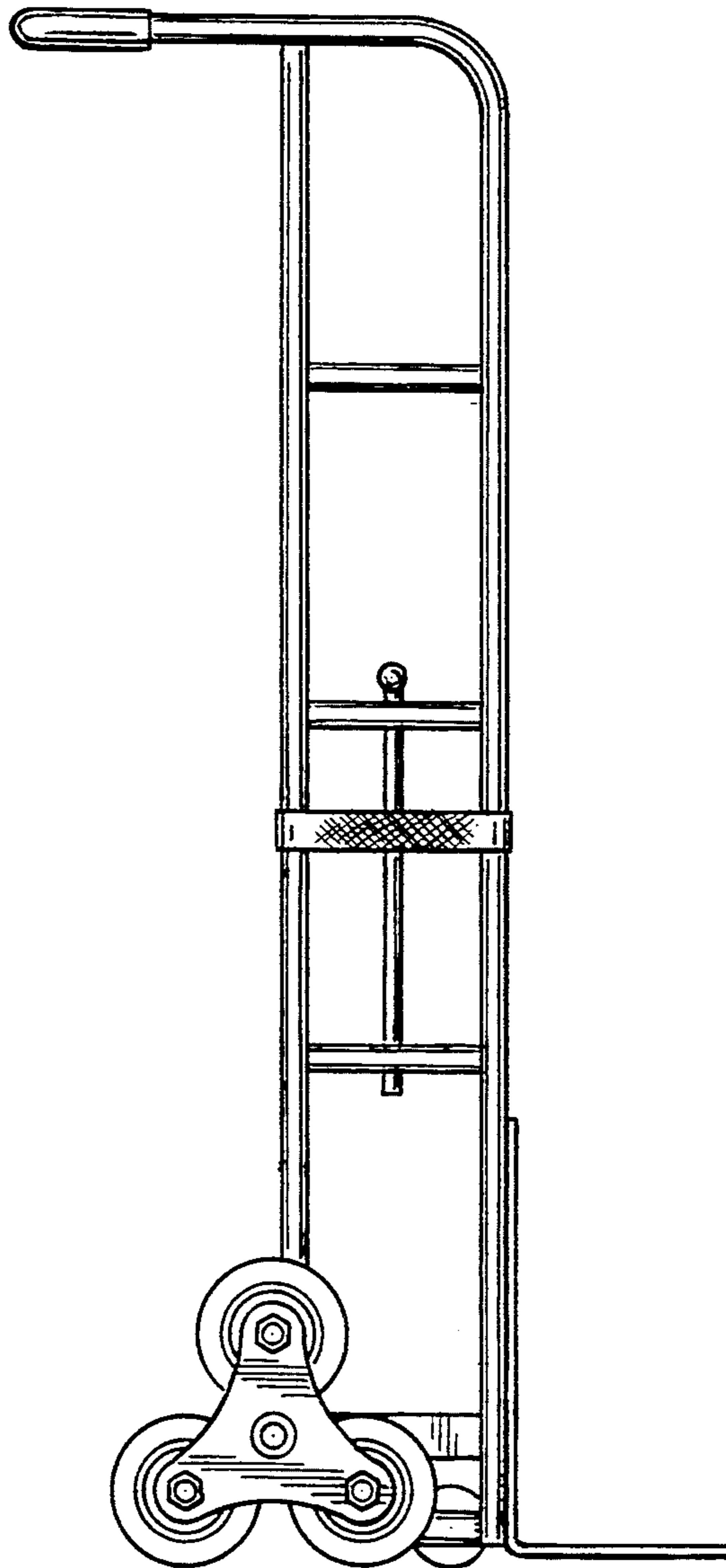

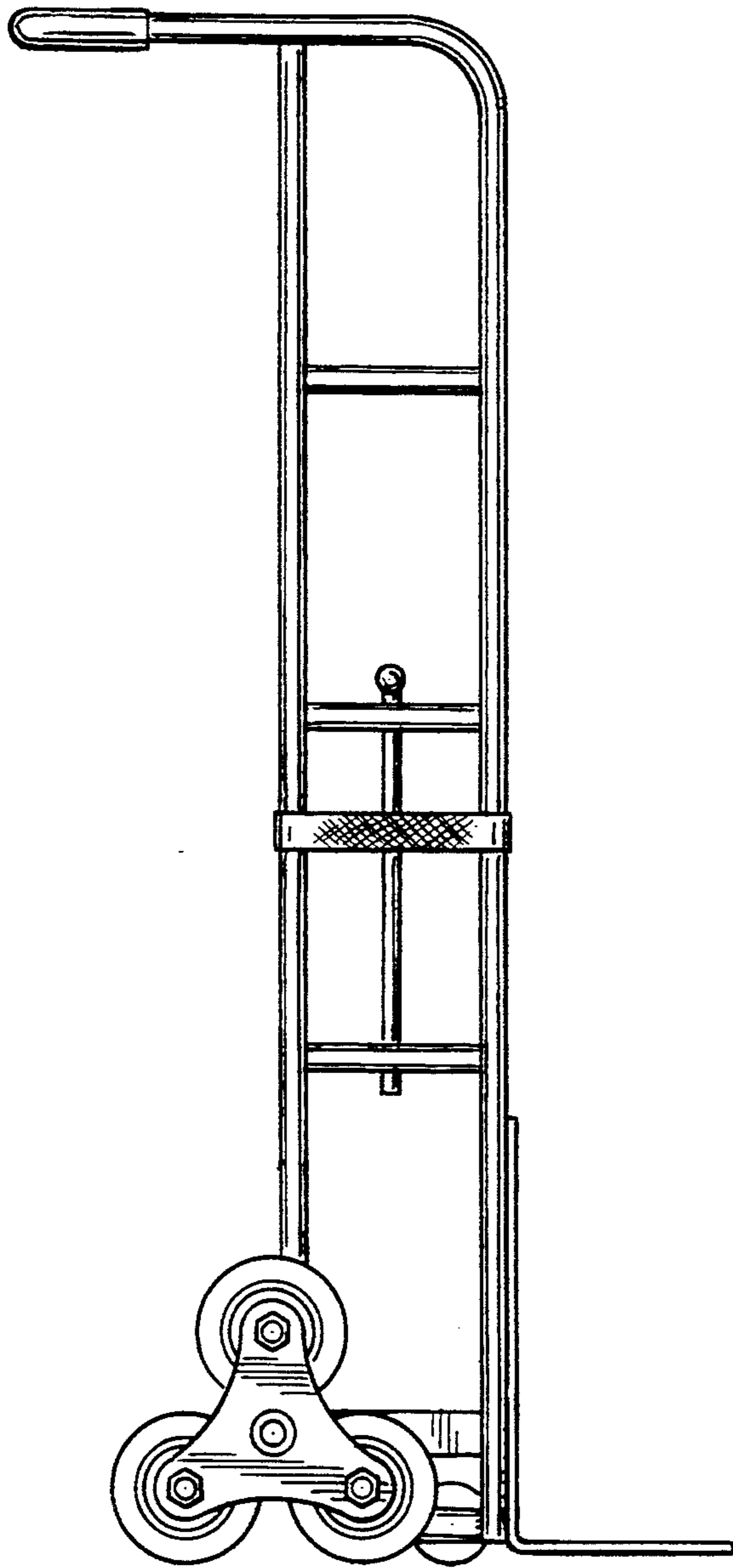

FIG. 1

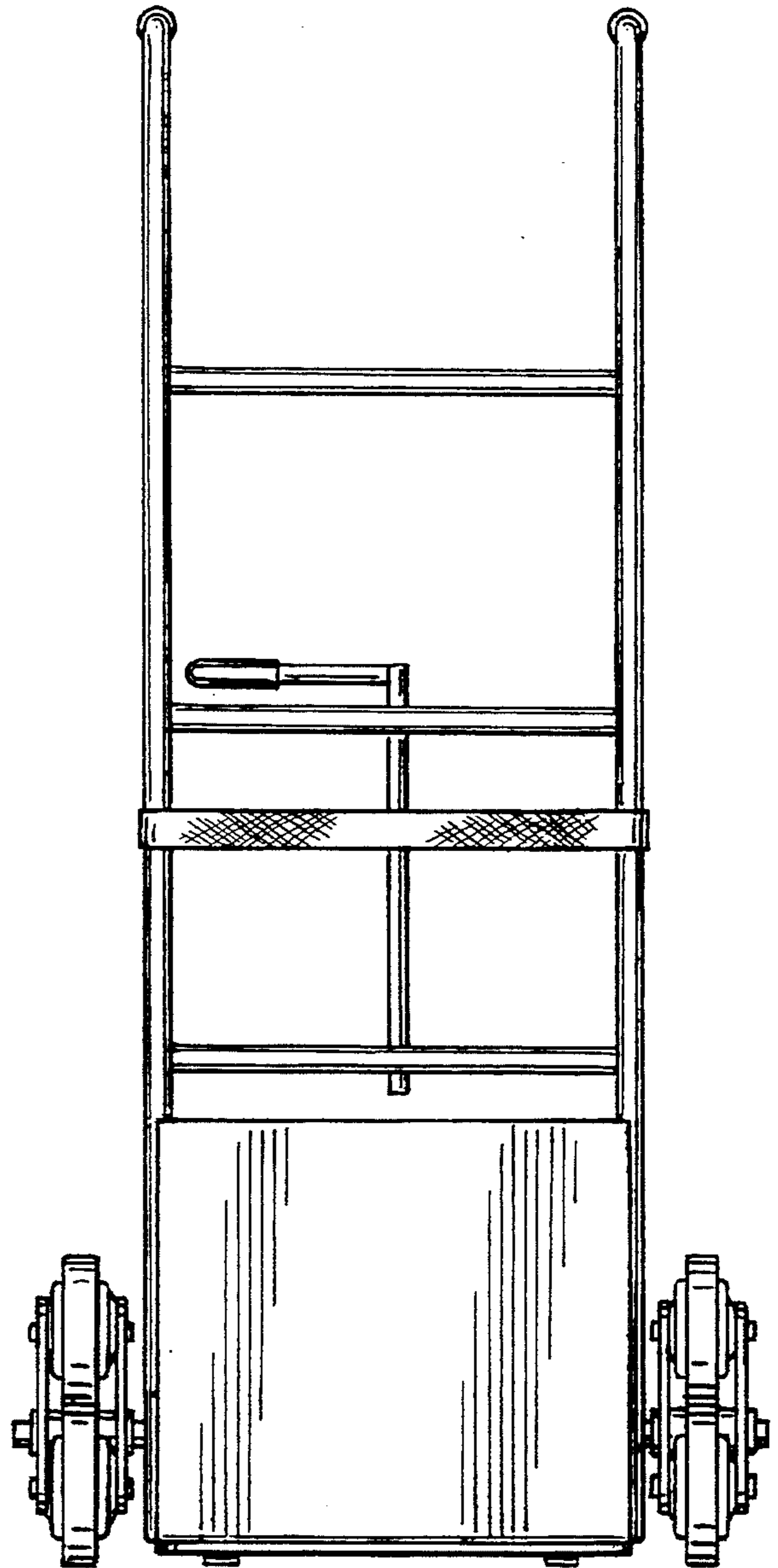

FIG. 2

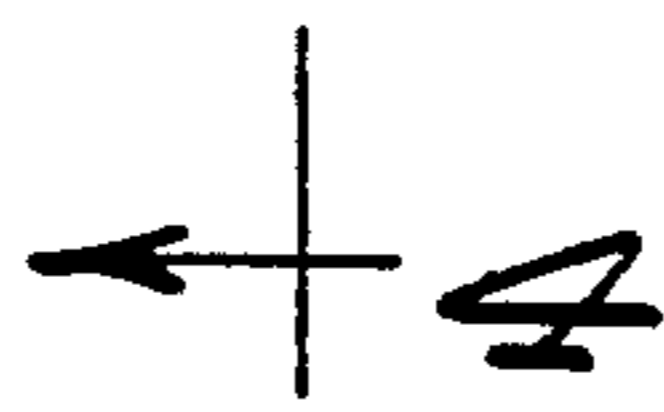
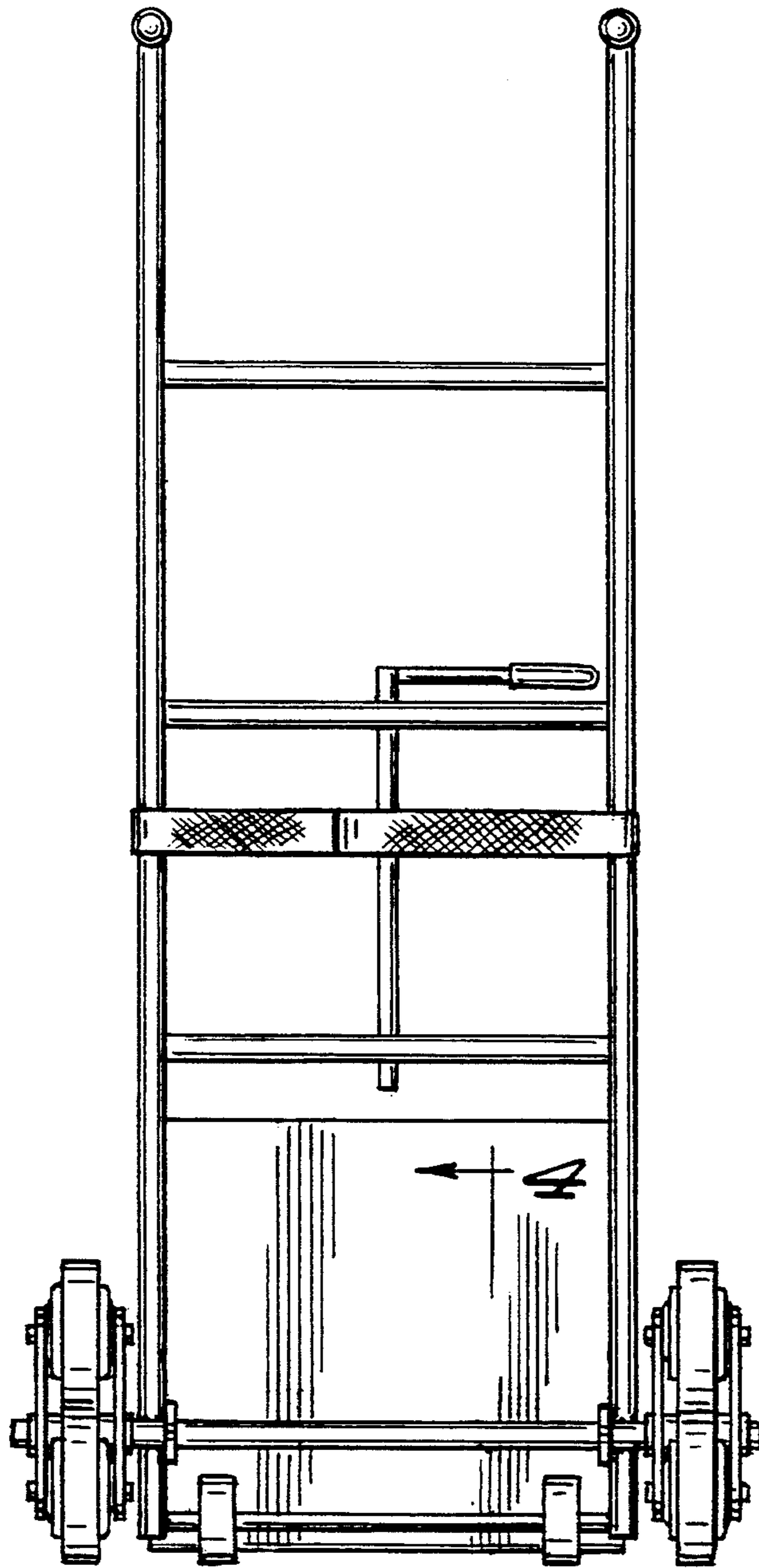

FIG. 3

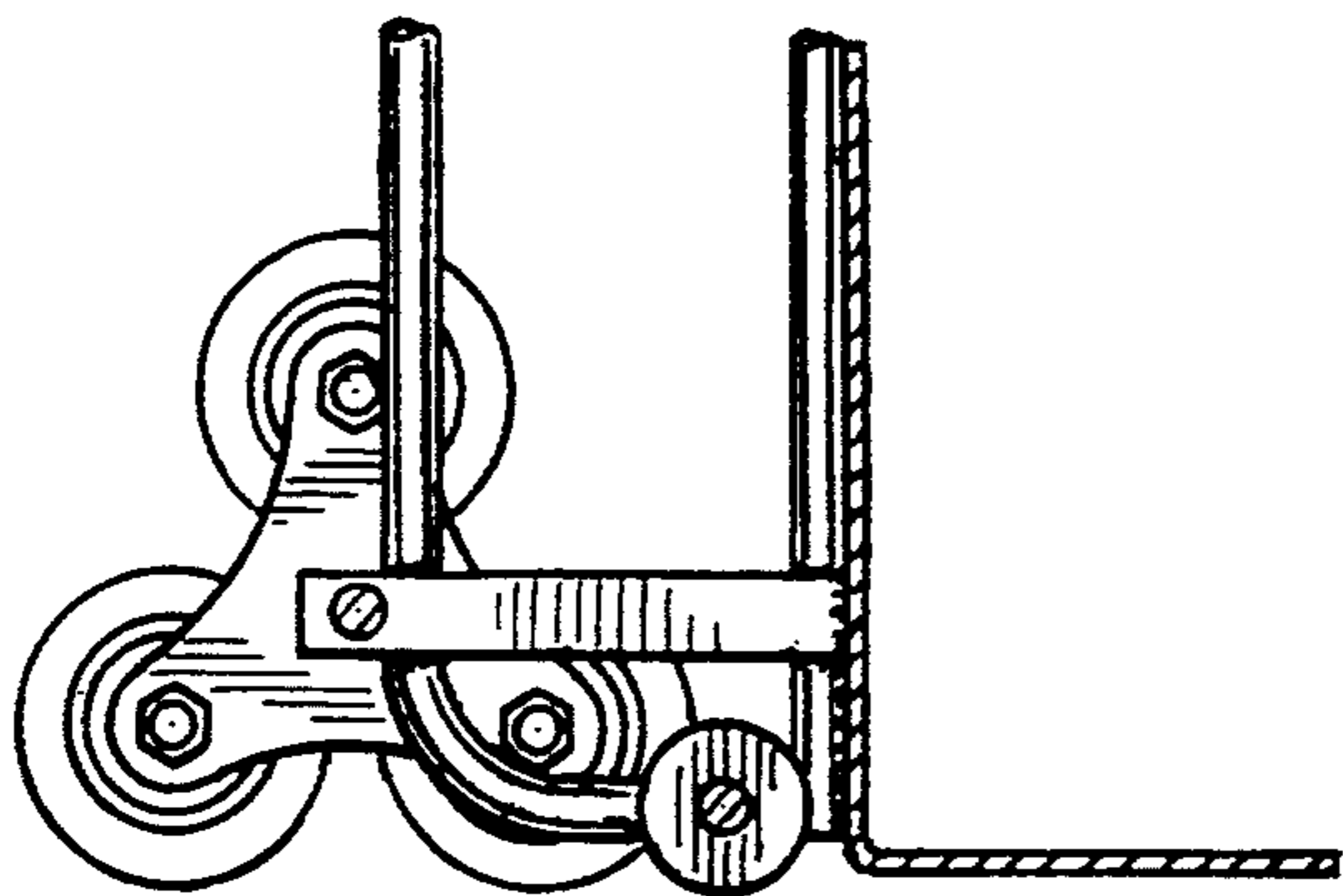

FIG. 4

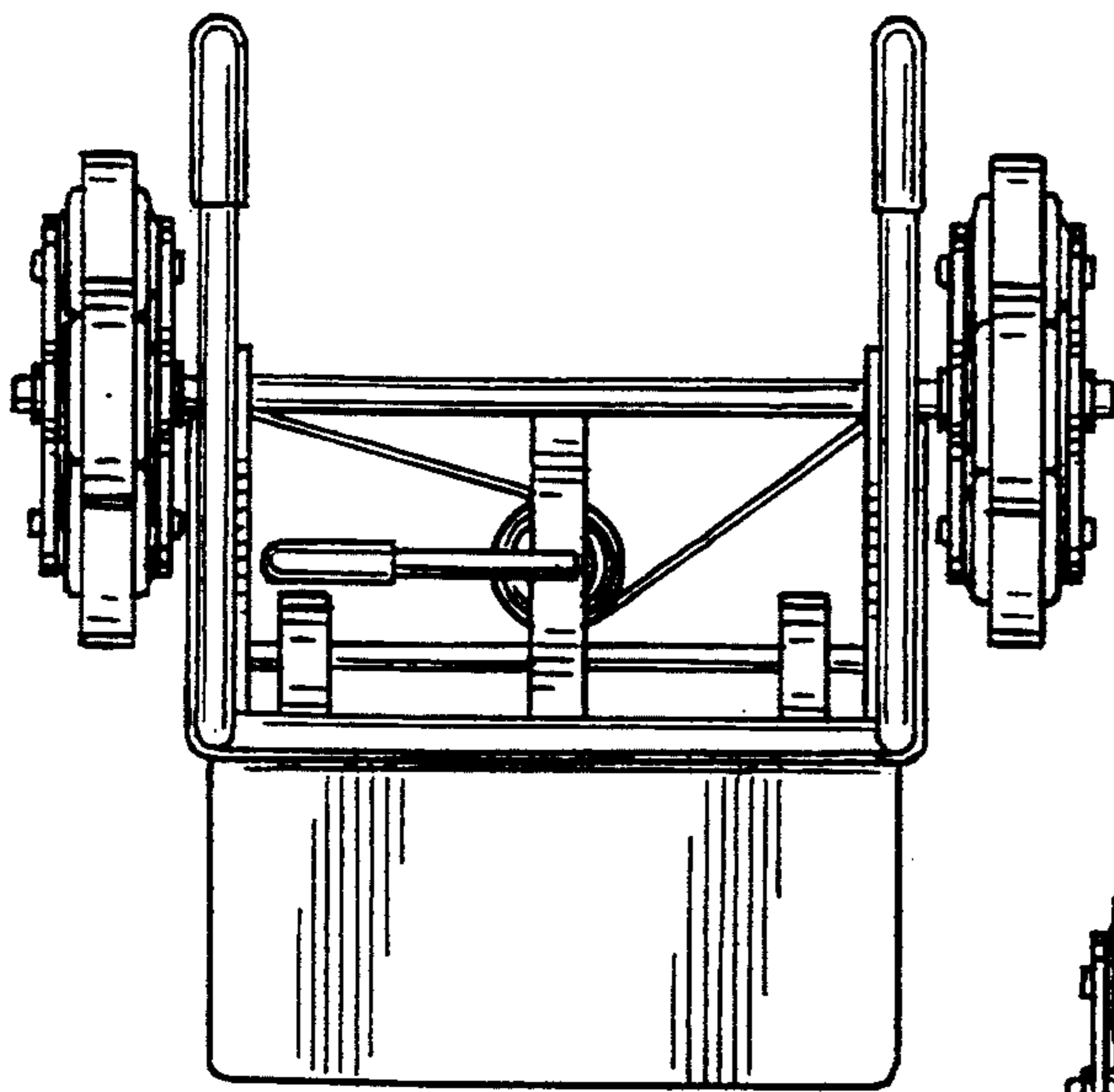
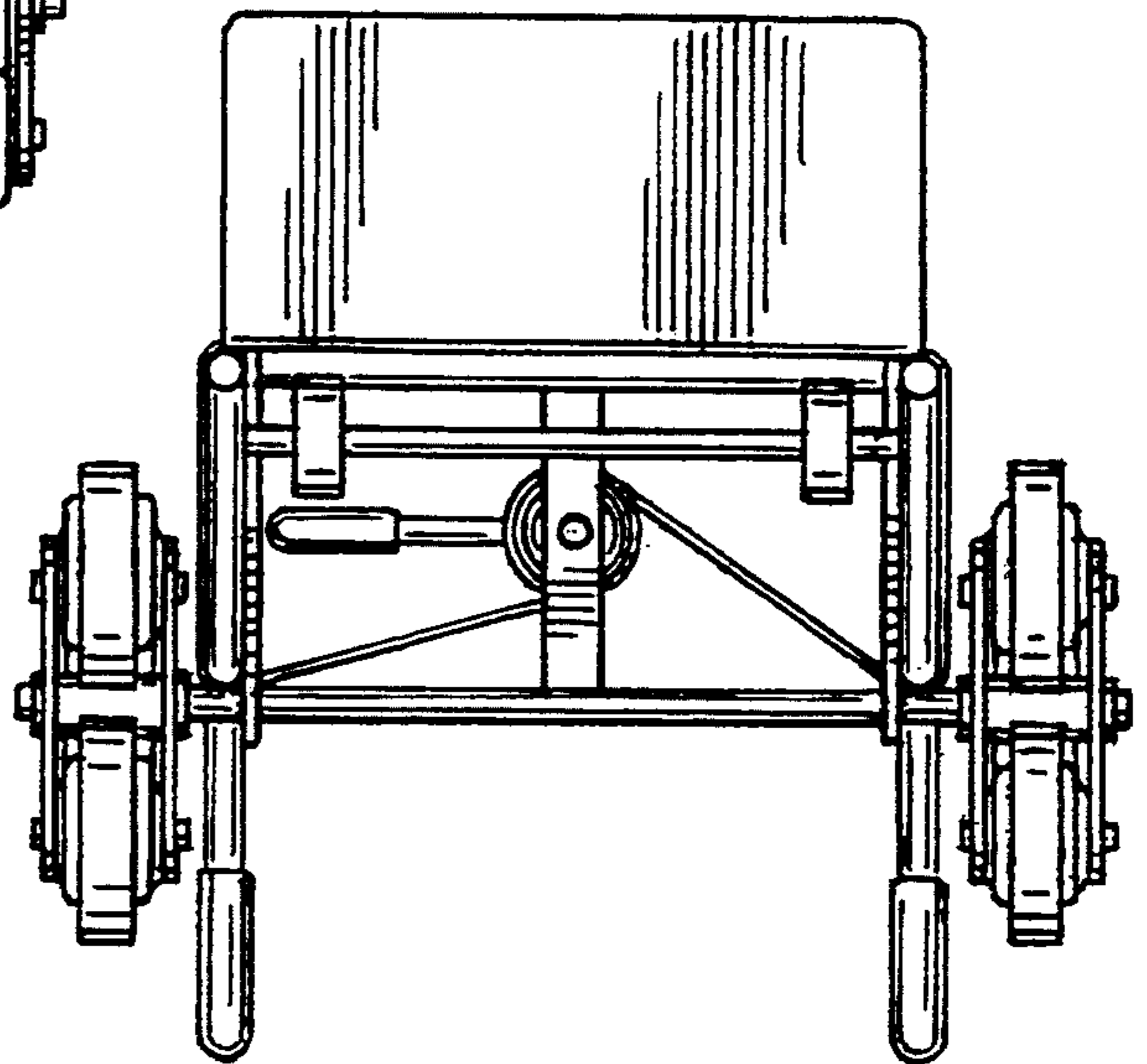

FIG. 5

FIG. 6



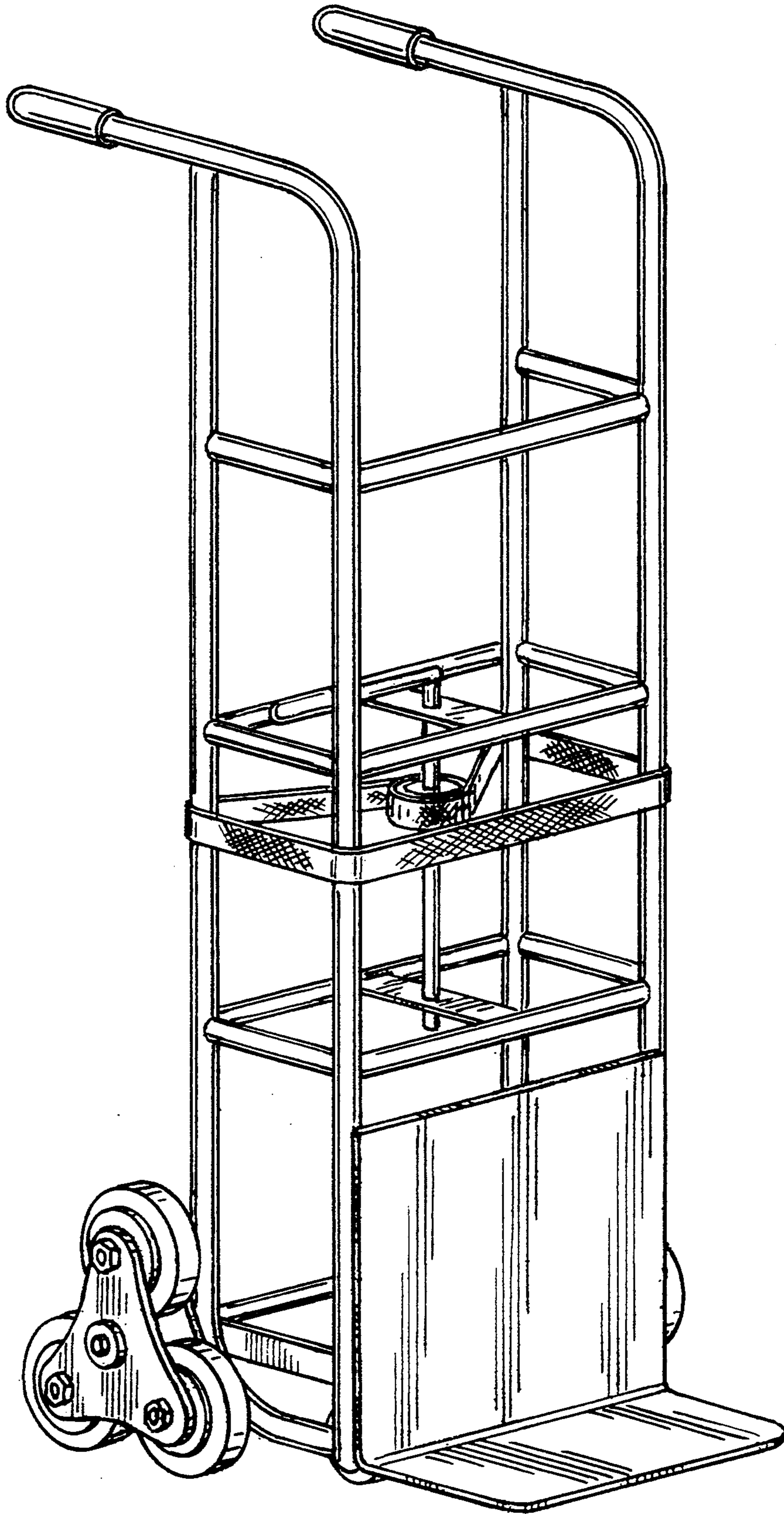

FIG. 7